

Modułowy system magazynka MRS2



© 2015–2025 Renishaw plc. Wszelkie prawa zastrzeżone.

Bez pisemnej zgody firmy Renishaw niniejszego dokumentu nie można w całości ani w części kopiować, powielać lub w jakikolwiek sposób inny przenosić na inny nośnik ani tłumaczyć na inne języki.

Zastrzeżenie

MIMO ŻE DOŁOŻONO WSZELKICH STARAŃ, ABY ZWERYFIKOWAĆ DOKŁADNOŚĆ NINIEJSZEGO DOKUMENTU W CHWILI JEGO PUBLIKACJI, W MAKSYMALNYM ZAKRESIE DOZWOLONYM PRZEZ PRZEPISY PRAWA WYŁĄCZA SIĘ WSZELKIE WYNIKAJĄCE Z NIEGO GWARANCJE, WARUNKI, OBIETNICE I ODPOWIEDZIALNOŚĆ PRAWNĄ.

FIRMA RENISHAW ZASTRZEGA PRAWO DO WPROWADZANIA ZMIAN W NINIEJSZYM DOKUMENCIE ORAZ W OPISANYCH W NIM URZĄDZENIACH, OPROGRAMOWANIU I DANYCH TECHNICZNYCH BEZ OBOWIĄZKU POWIADOMIENIA O TAKICH ZMIANACH.

Znaki towarowe

RENISHAW®, symbol sondy, REVO® i AGILITY® są zastrzeżonymi znakami towarowymi firmy Renishaw plc.

Nazwy produktów Renishaw, oznaczenia i znak „apply innovation” są znakami towarowymi firmy Renishaw plc lub jej podmiotów zależnych.

Inne nazwy marek, produktów i firm są znakami towarowymi odpowiednich właścicieli.

Dane rejestracyjne firmy

Renishaw plc. Zarejestrowano w Anglii i Walii. Numer rejestracyjny spółki: 1106260. Siedziba: New Mills, Wotton-under-Edge, Gloucestershire, GL12 8JR, Wielka Brytania.

WERSJA POLSKA

Opakowanie

Aby pomóc użytkownikowi końcowemu w recyklingu i utylizacji materiałów użytych w różnych elementach opakowania, poniżej przedstawiono zestawienie tych materiałów:

Element opakowania	Materiał	Kod zgodnie z 94/62/WE	Numer 94/62/WE
Opakowanie zewnętrzne	Płyta pilśniowa falista	PAP	20
Wypełniacz opakowania	Płyta pilśniowa falista	PAP	20
Worek	Polietylen niskiej gęstości	LDPE	4

Instrukcje montażu MRS2

Jednorzędowy

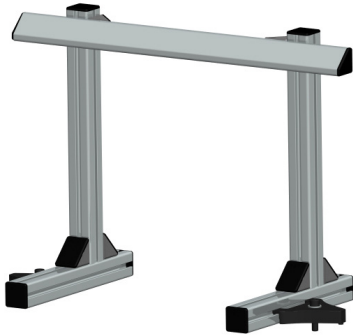

Dwurzędowy



Trzyrzędowy



Dwurzędowy ze wspornikiem



200 mm
A-6007-1020



400 mm
A-6007-1040

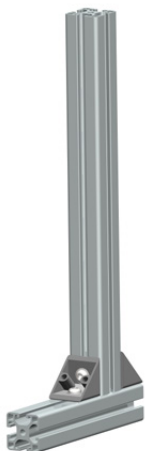



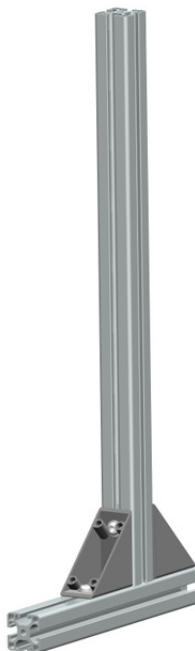



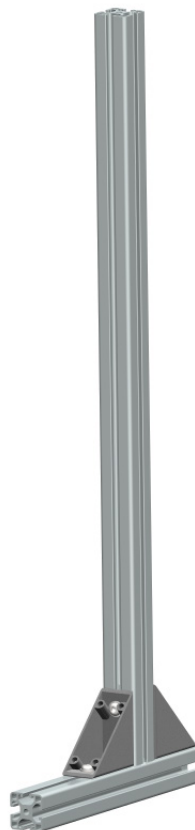







600 mm
A-6007-1060



800 mm
A-6007-1080



	200 mm A-6007-1020	400 mm A-6007-1040	600 mm A-6007-1060	800 mm A-6007-1080
	4	4	-	-
	-	-	4	4
	8	8	16	16
	8	8	16	16
	8	8	16	16
 200 mm	4	2	-	-
 300 mm	-	-	2	2
 400 mm	-	2	-	-
 600 mm	-	-	2	-
 800 mm	-	-	-	2
	6	6	6	6
	4	4	-	-
	-	-	4	4
	2	2	2	2

200 mm i 400 mm — tylko nogi

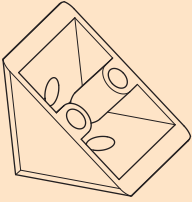

x 1



x 2

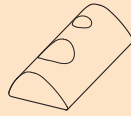

x 2



x 2

x 4

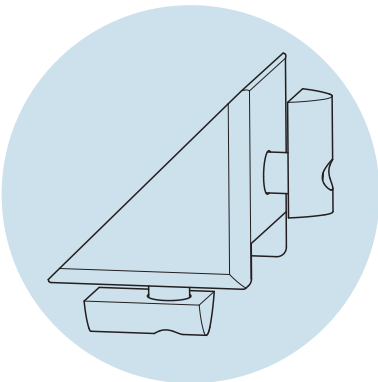
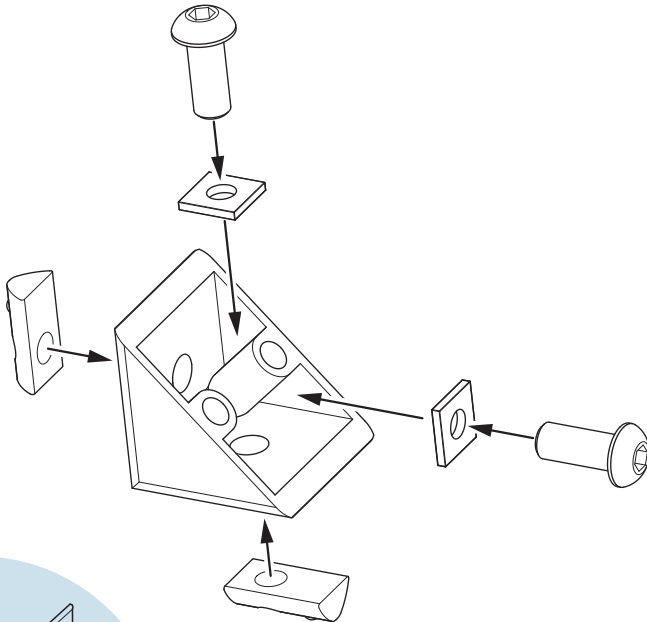

600 mm i 800 mm — tylko nogi

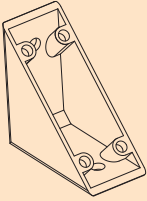

× 1

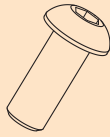

× 4

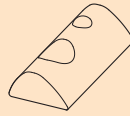

× 4



× 4

× 4

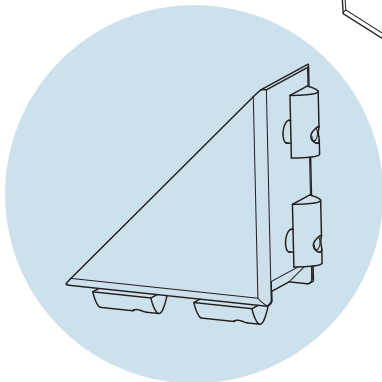
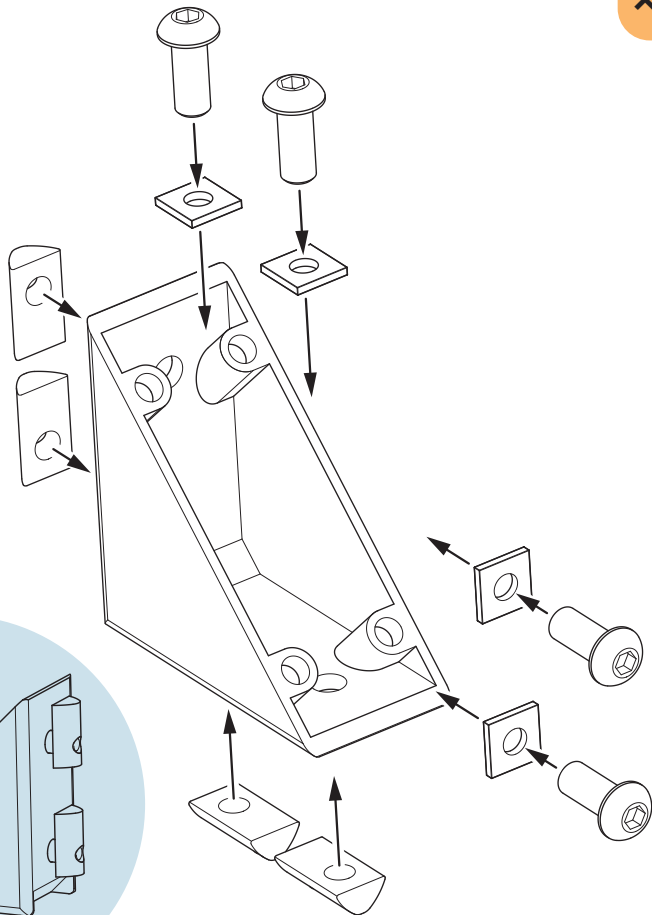

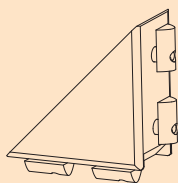

× 2

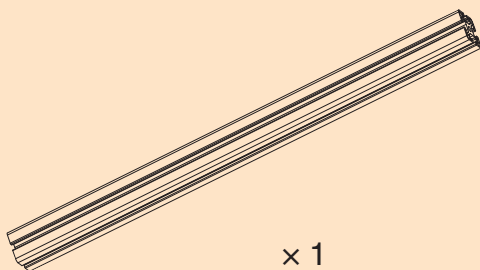

× 1

× 2

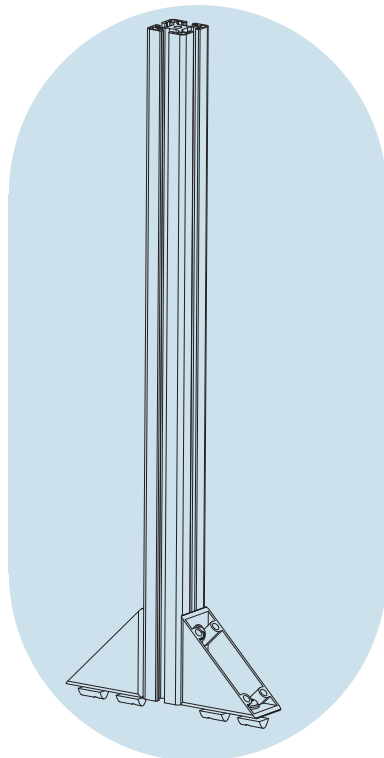
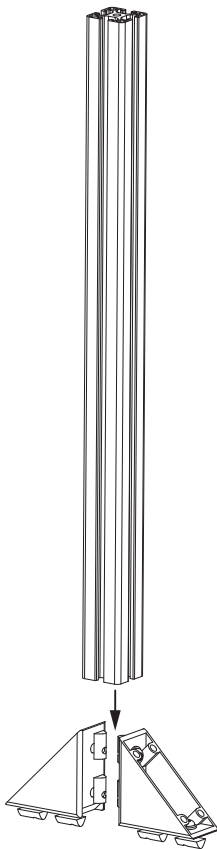

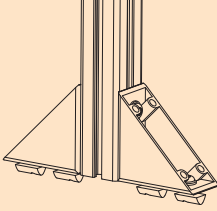

× 1

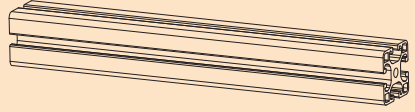

× 1

× 2

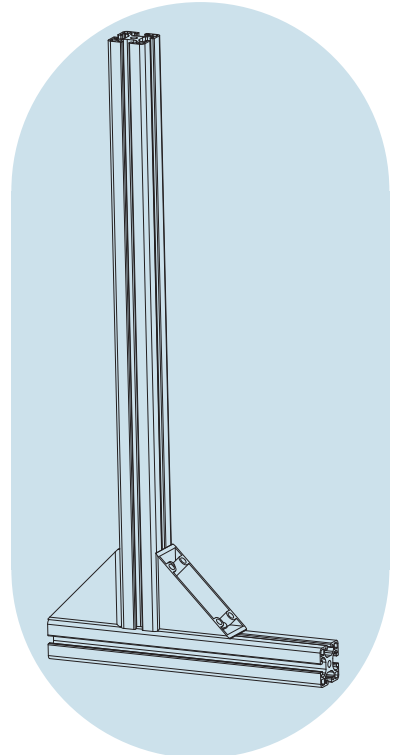
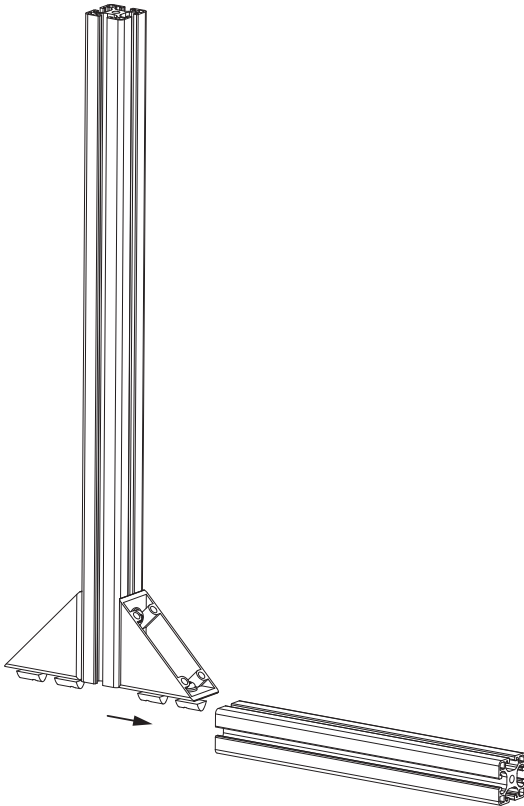

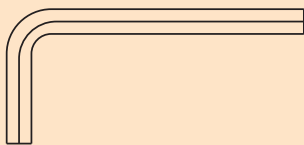

Moment dokręcania śruby 7,5 Nm

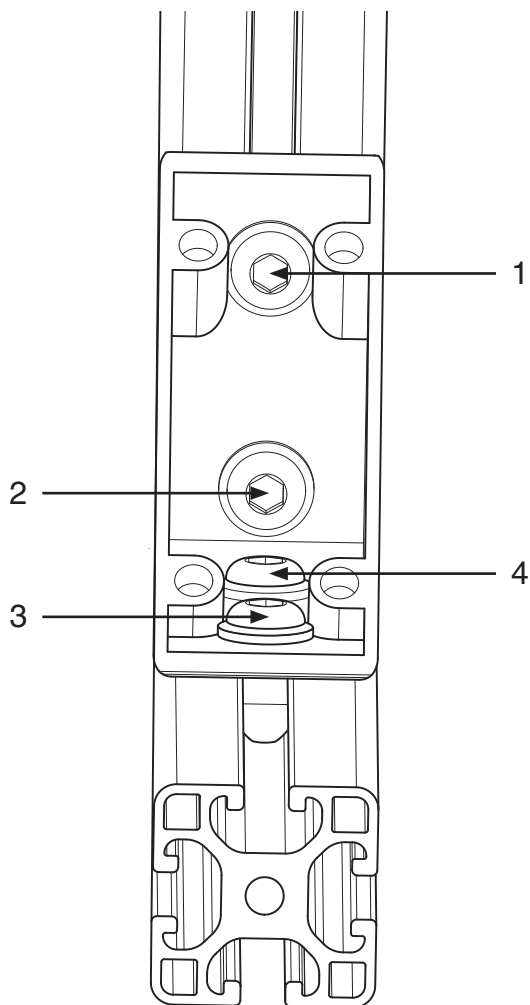



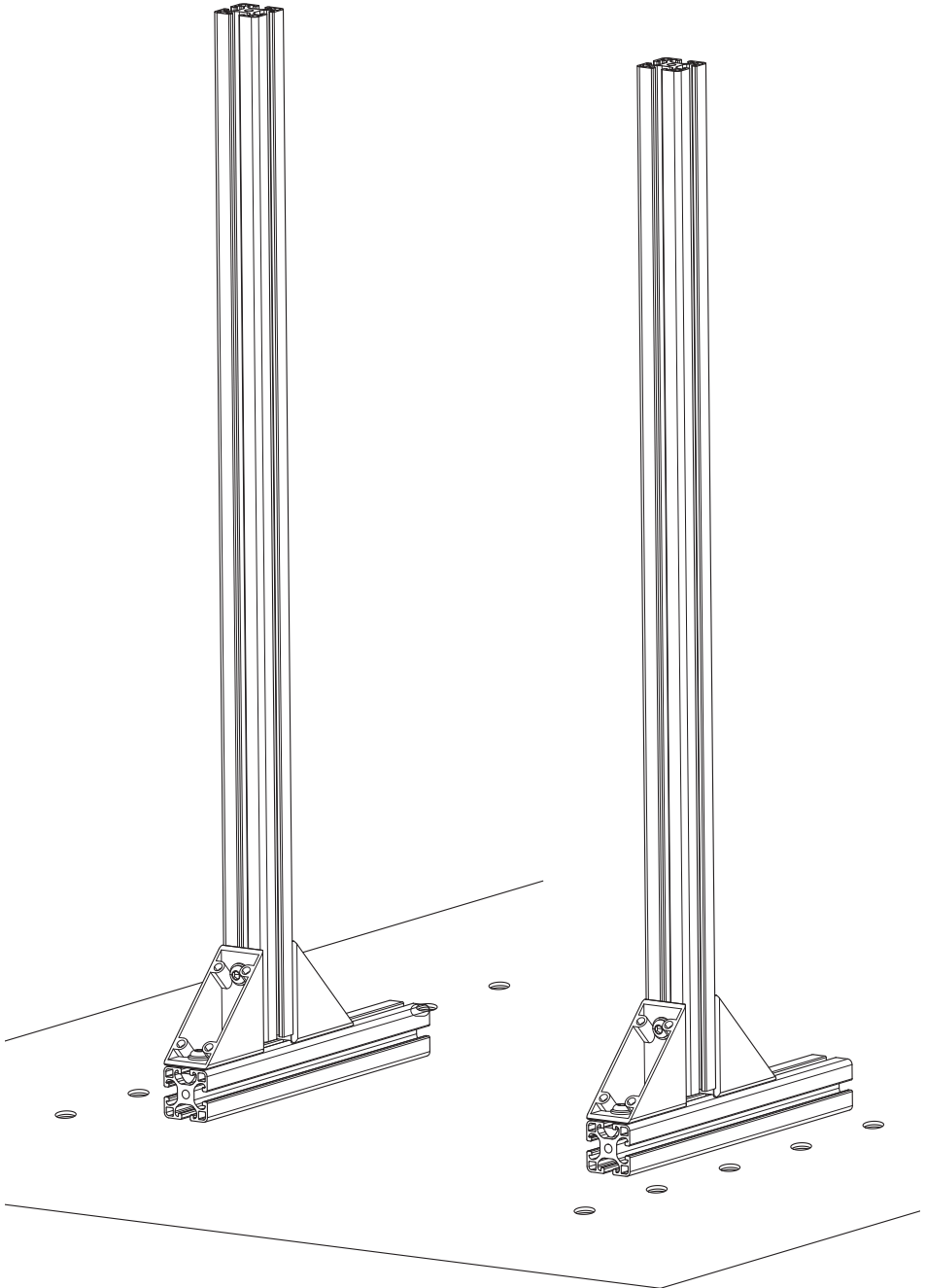

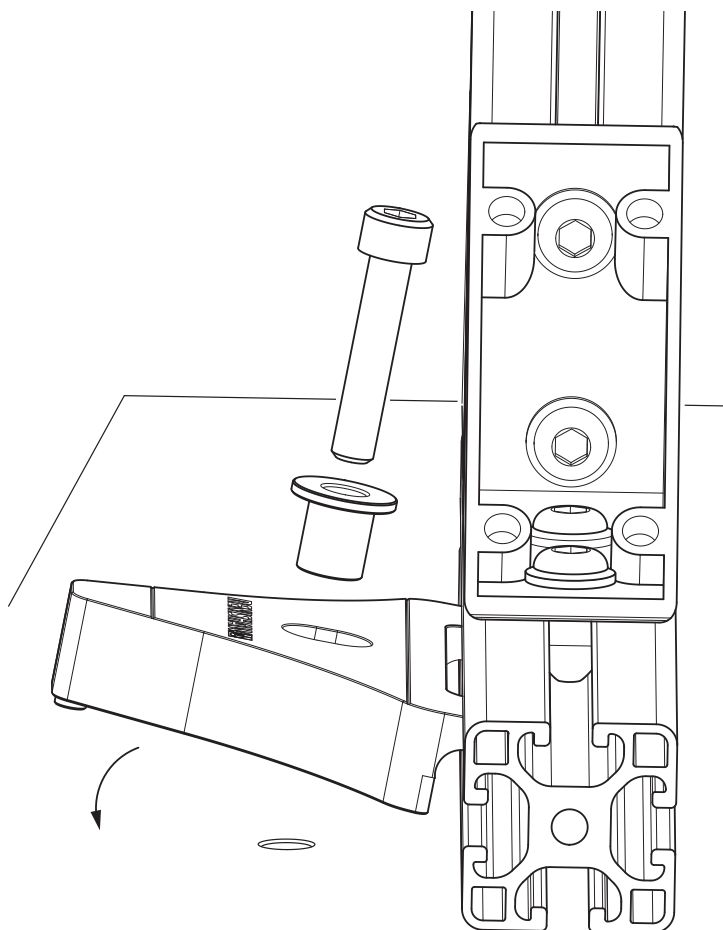



× 4





Ta strona została celowo pozostawiona pusta.

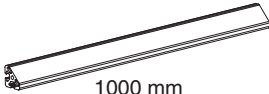

	400 mm A-6007-2040	600 mm A-6007-2060	1000 mm A-6007-2100
	2	2	2
	4	4	4
	4	4	4
	4	4	4
 400 mm	1	-	-
 600 mm	-	1	-
 1000 mm	-	-	1
	2	2	2
	2	2	2

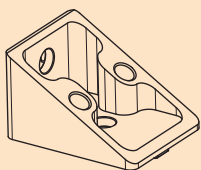

× 1

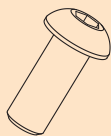

× 2

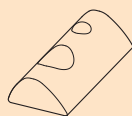

× 2



× 2

× 2

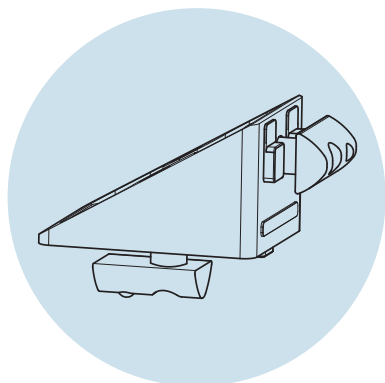
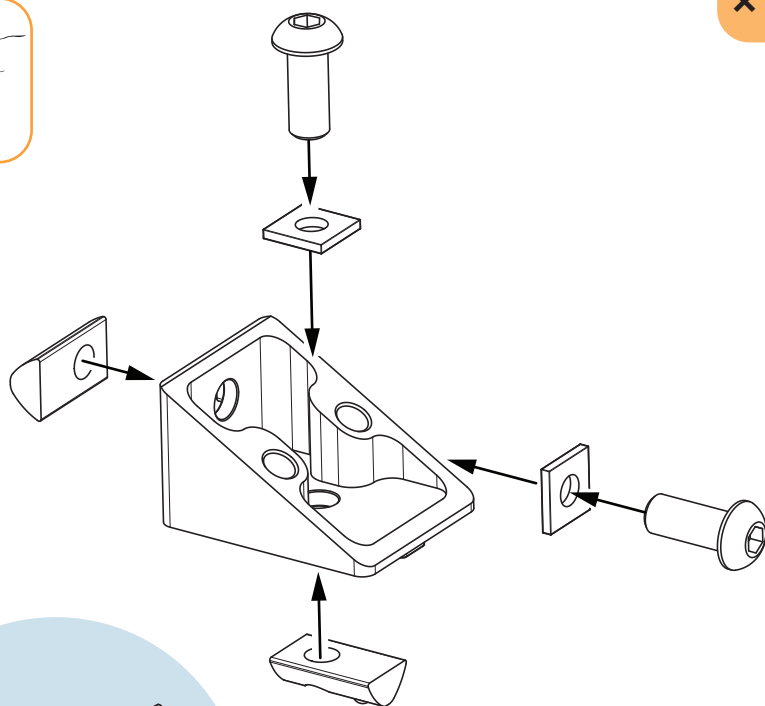

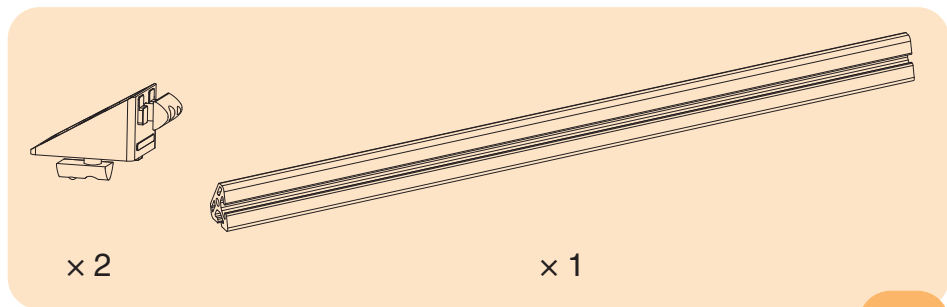



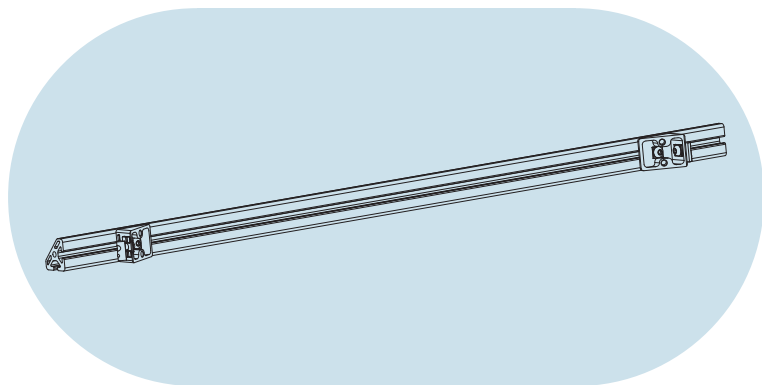
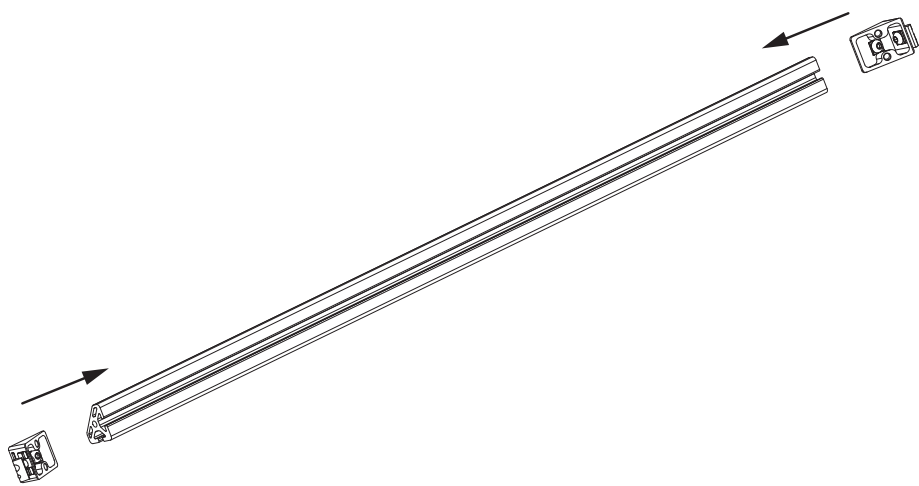

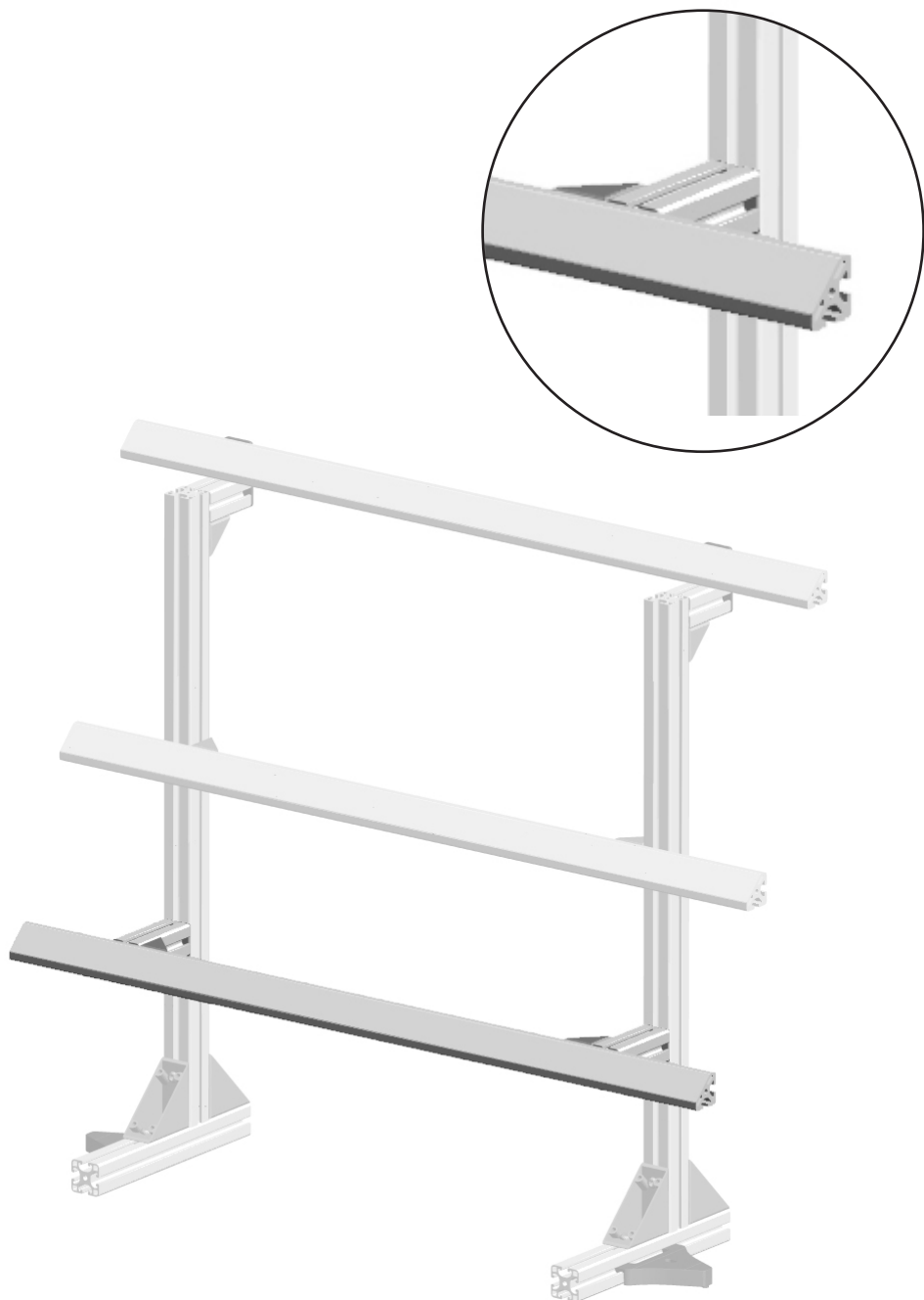





x 1





	400 mm A-6007-3040	600 mm A-6007-3060	1000 mm A-6007-3100
 400 mm	1	-	-
 600 mm	-	1	-
 1000 mm	-	-	1
	4	4	4
	8	8	8
	8	8	8
	8	8	8
	2	2	2
	4	4	4
	2	2	2

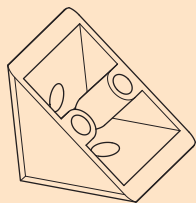

x 1

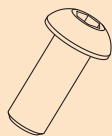

x 2

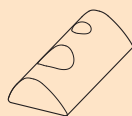

x 2



x 2

x 4

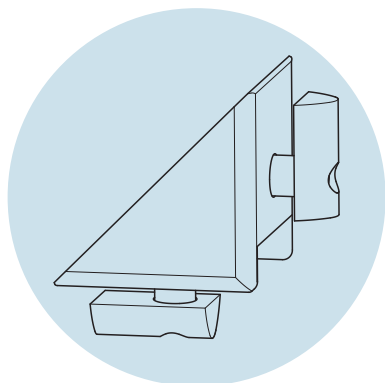
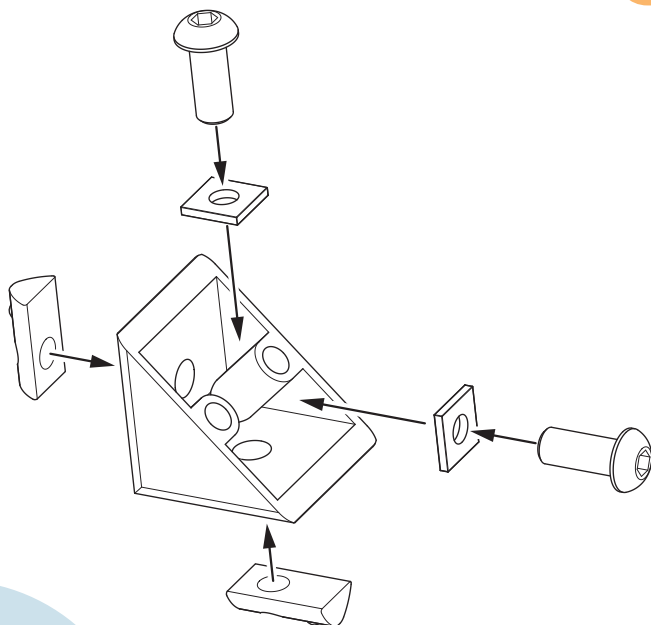

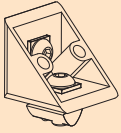

× 2

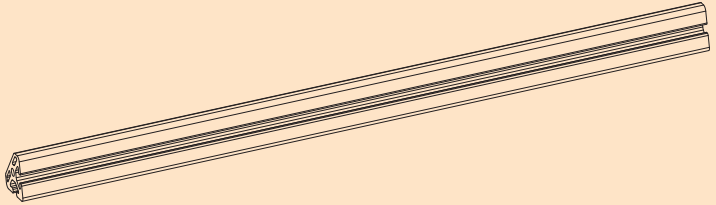

× 1

× 1

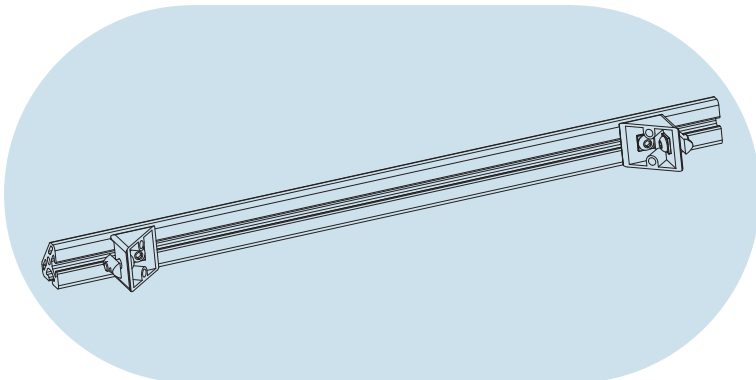
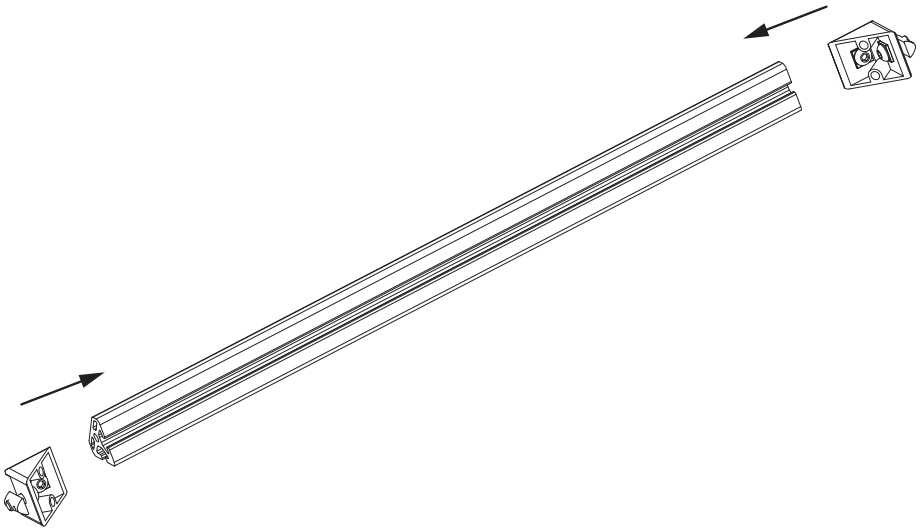

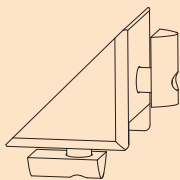

× 1

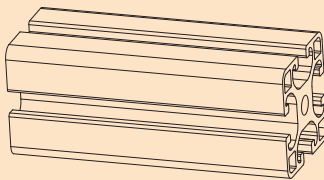

× 1

× 2

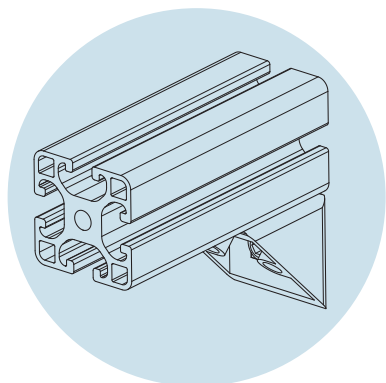
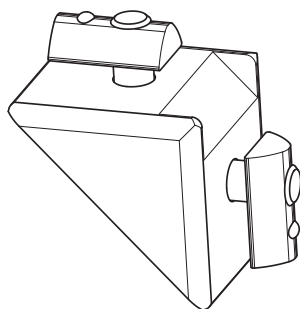
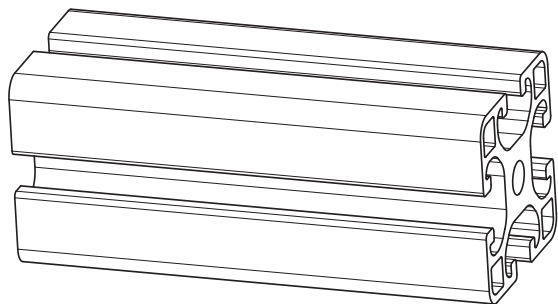

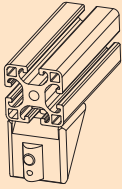

× 2







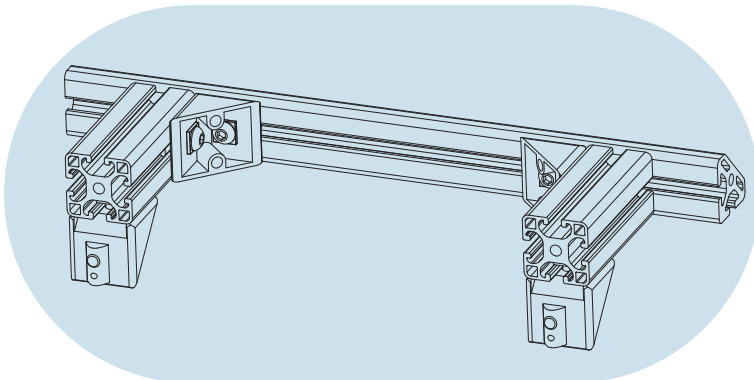
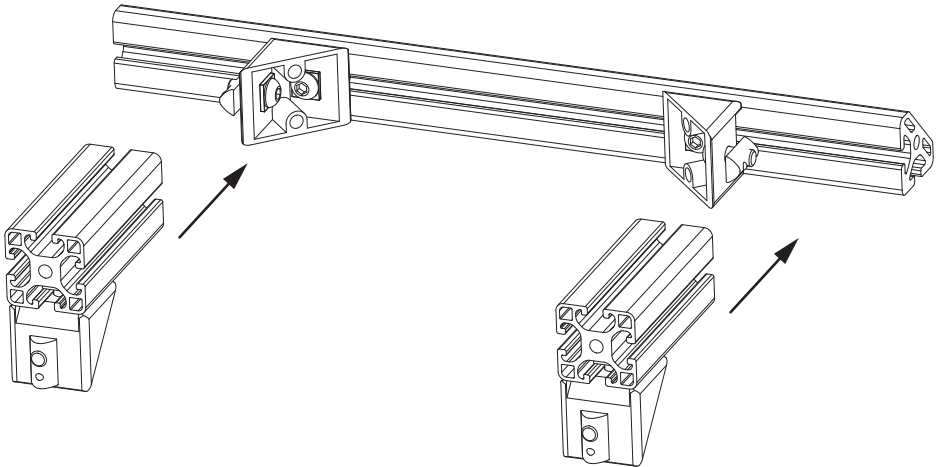



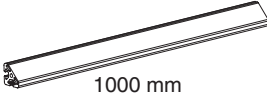

× 1

× 1

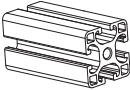



	400 mm A-6007-4040	600 mm A-6007-4060	1000 mm A-6007-4100
 400 mm	1	-	-
 600 mm	-	1	-
 1000 mm	-	-	1
	2	2	2
	4	4	4
	6	6	6
	2	2	2
	2	2	2
	4	4	4
	2	2	2
	2	2	2

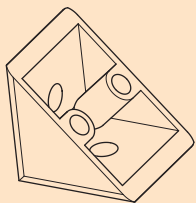

x 1

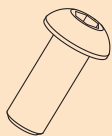

x 2

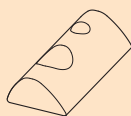

x 2



x 2

x 2

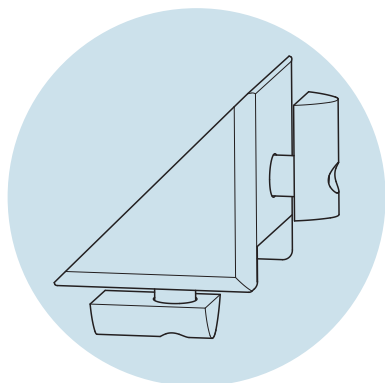
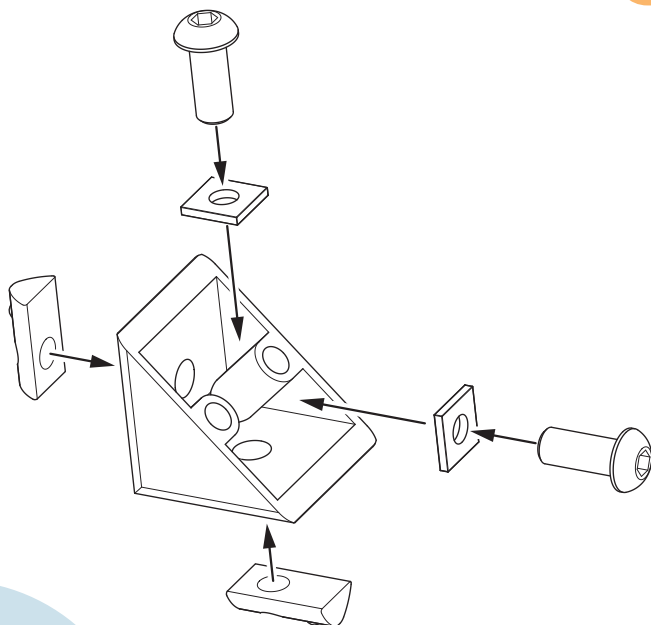

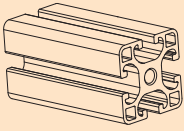

× 1

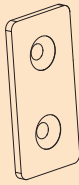

× 1

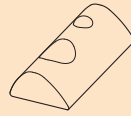

× 1



× 2

× 2

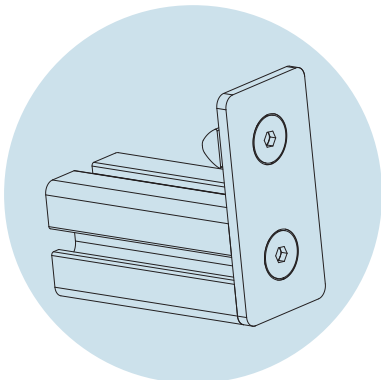
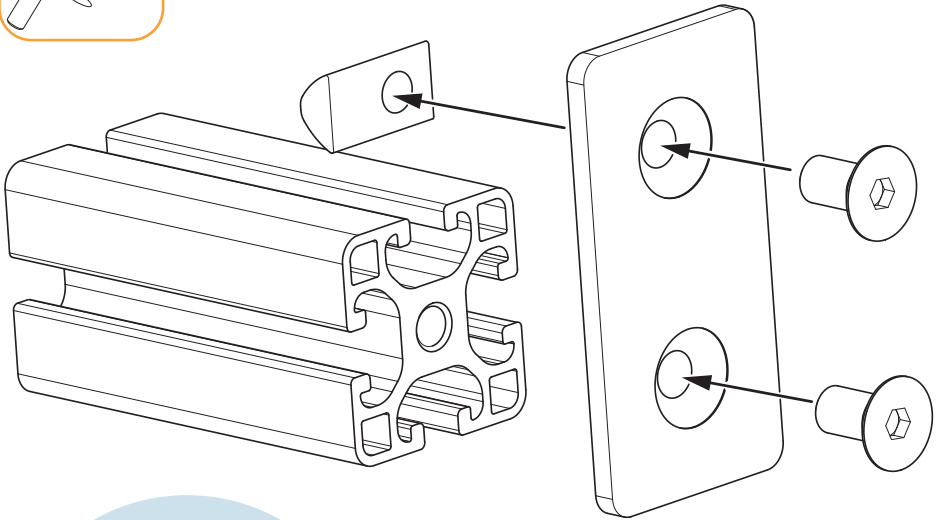

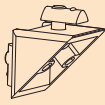

× 2

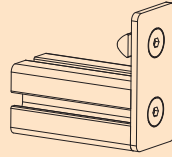

× 2

× 2

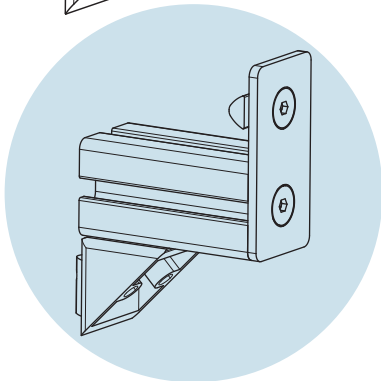
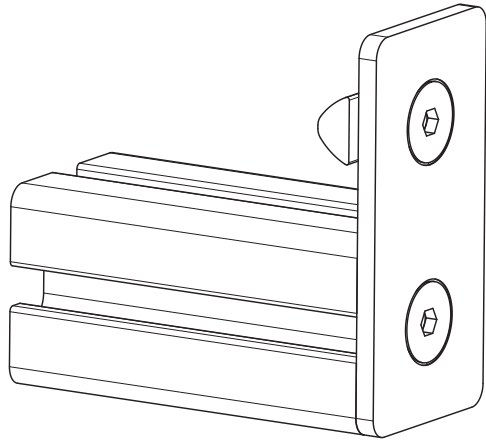
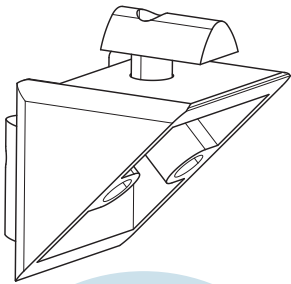

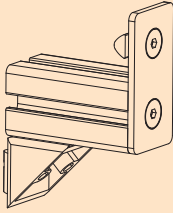

× 2

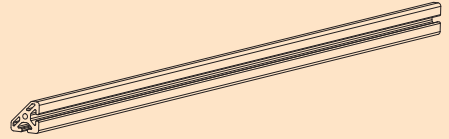

× 1

× 1

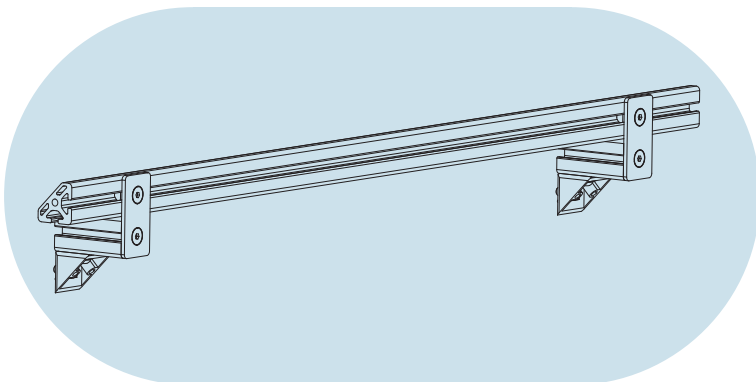
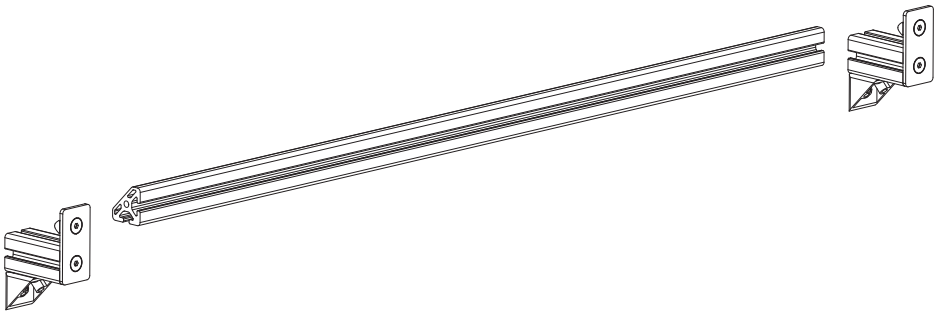



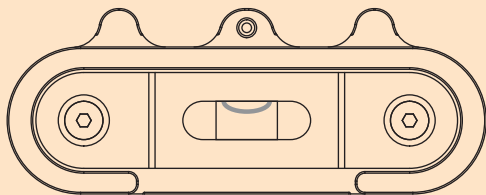

A-6007-0630

Ustawić szynę poziomo
przy użyciu dostarczonej
poziomnicy

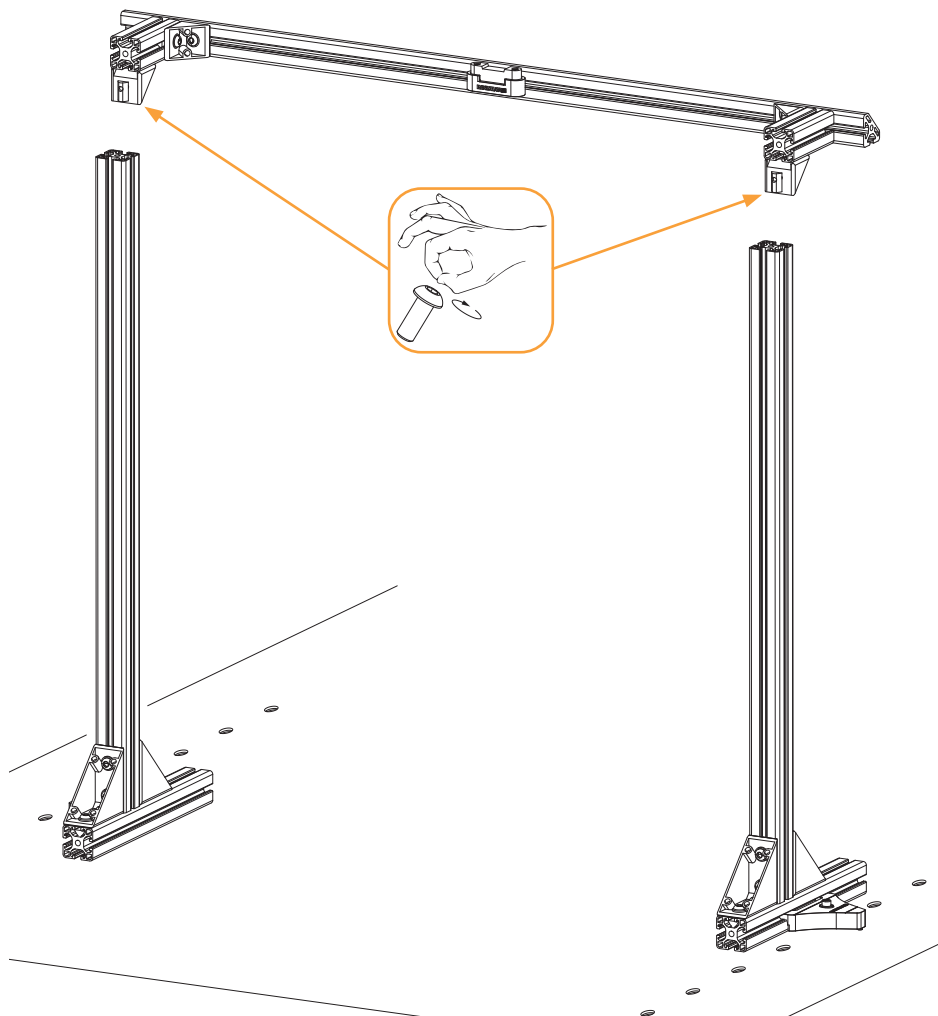

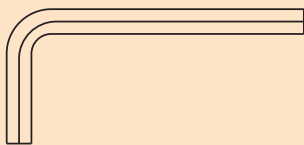

Moment dokręcania śruby 7,5 Nm

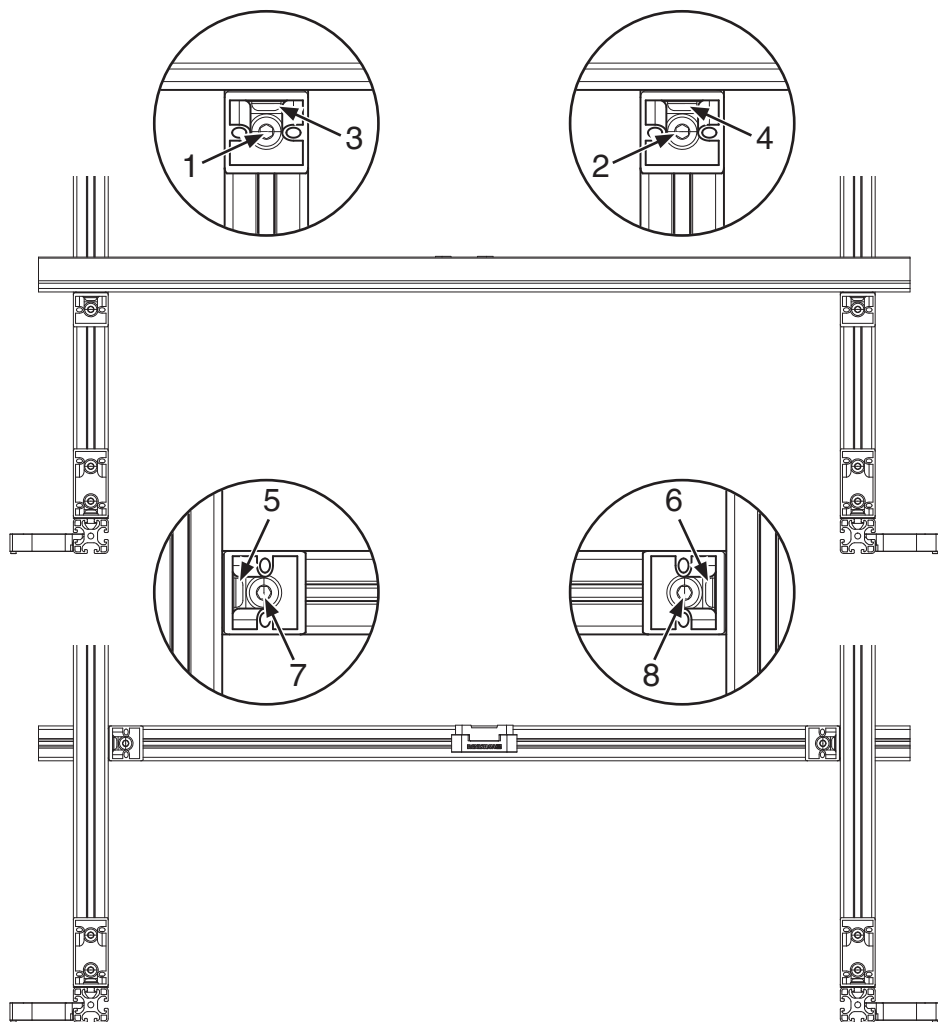

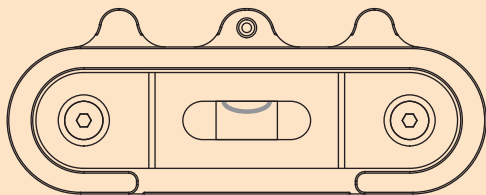

A-6007-0630

Ustawić szynę poziomo
przy użyciu dostarczonej
poziomnicy

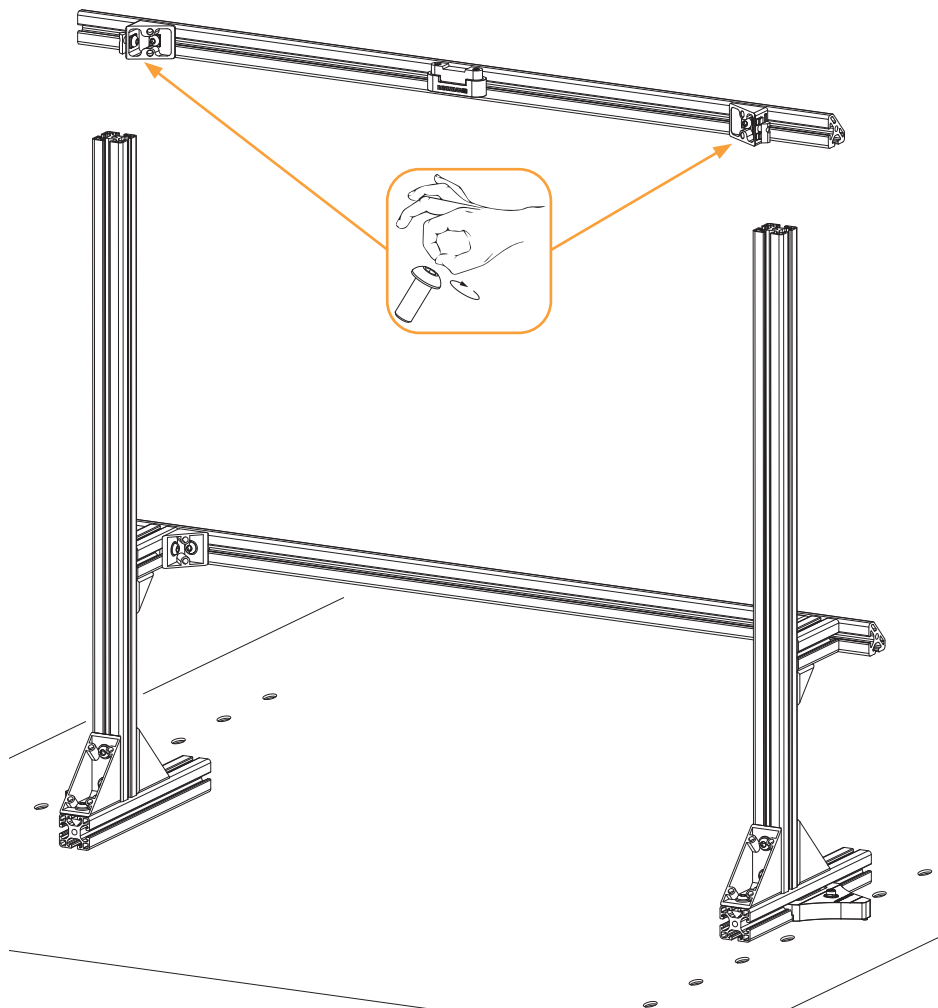

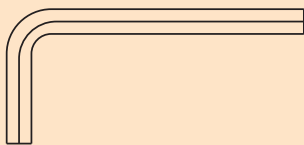

Moment dokręcania śruby 7,5 Nm

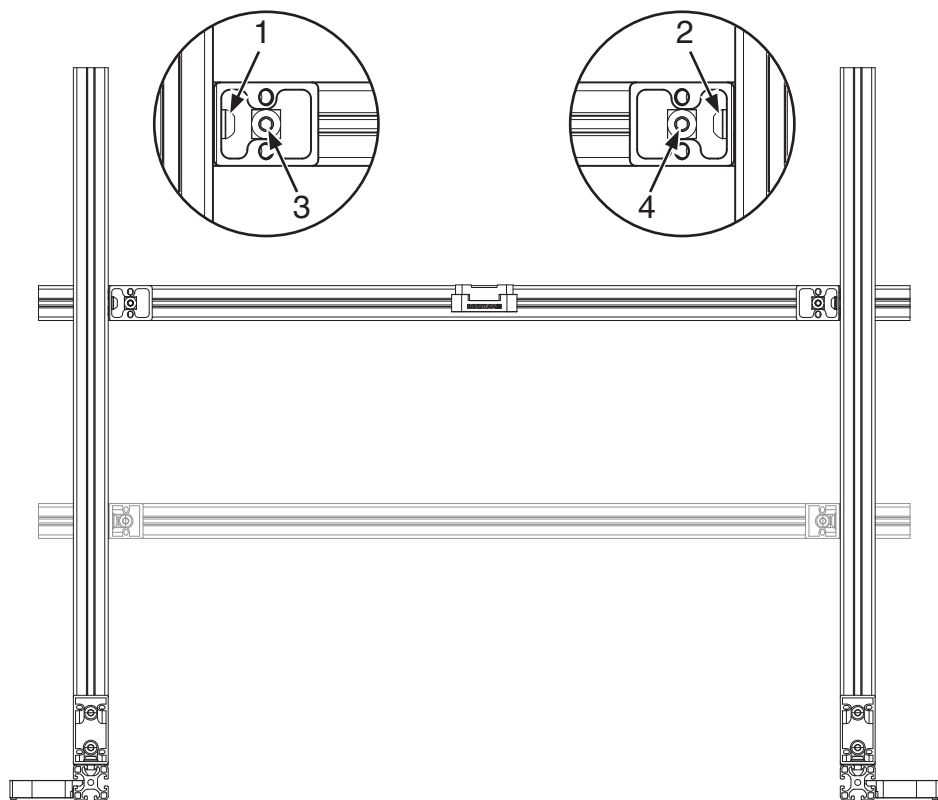

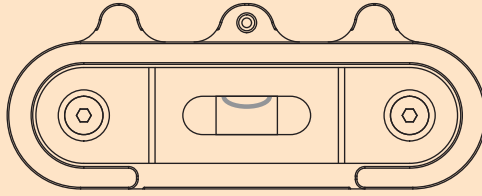

A-6007-0630

Ustawić szynę poziomo
przy użyciu dostarczonej
poziomnicy

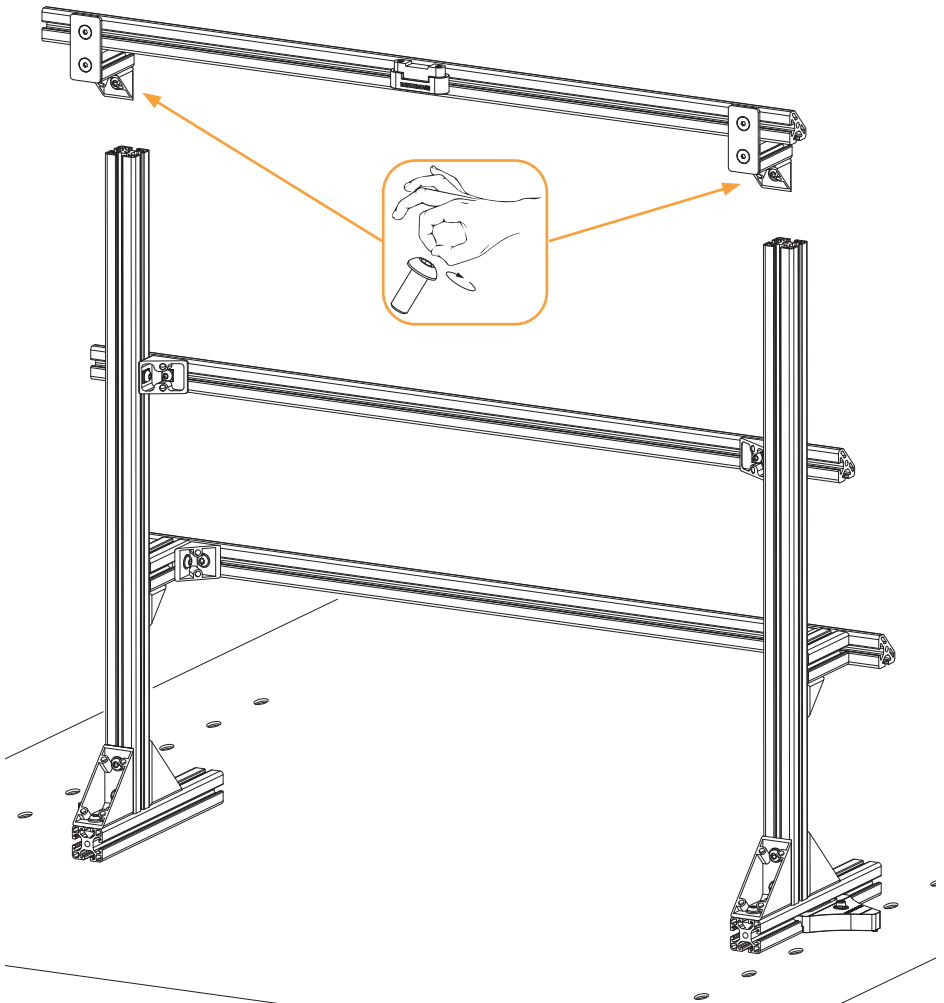

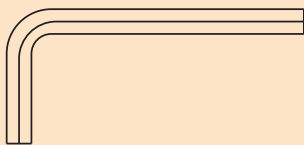

Moment dokręcania śruby 7,5 Nm

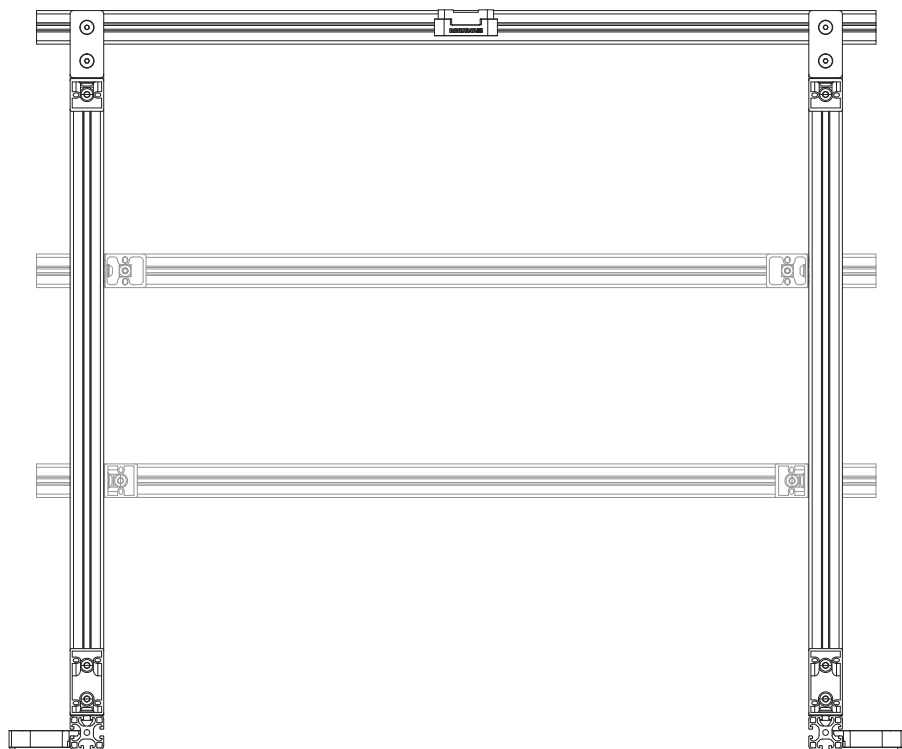
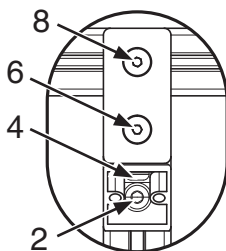
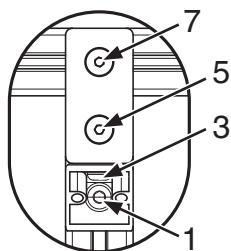

Instalacja typowego portu

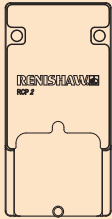

x 1



x 2

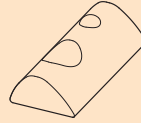

x 2

Typowa instalacja dla większości urządzeń REVO i 3-osiowych portów oraz stojaków montowanych na szynie.

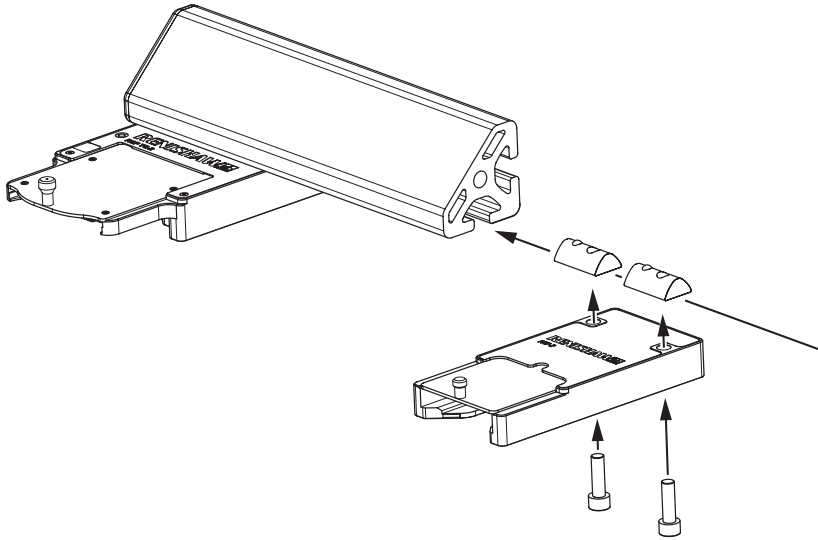

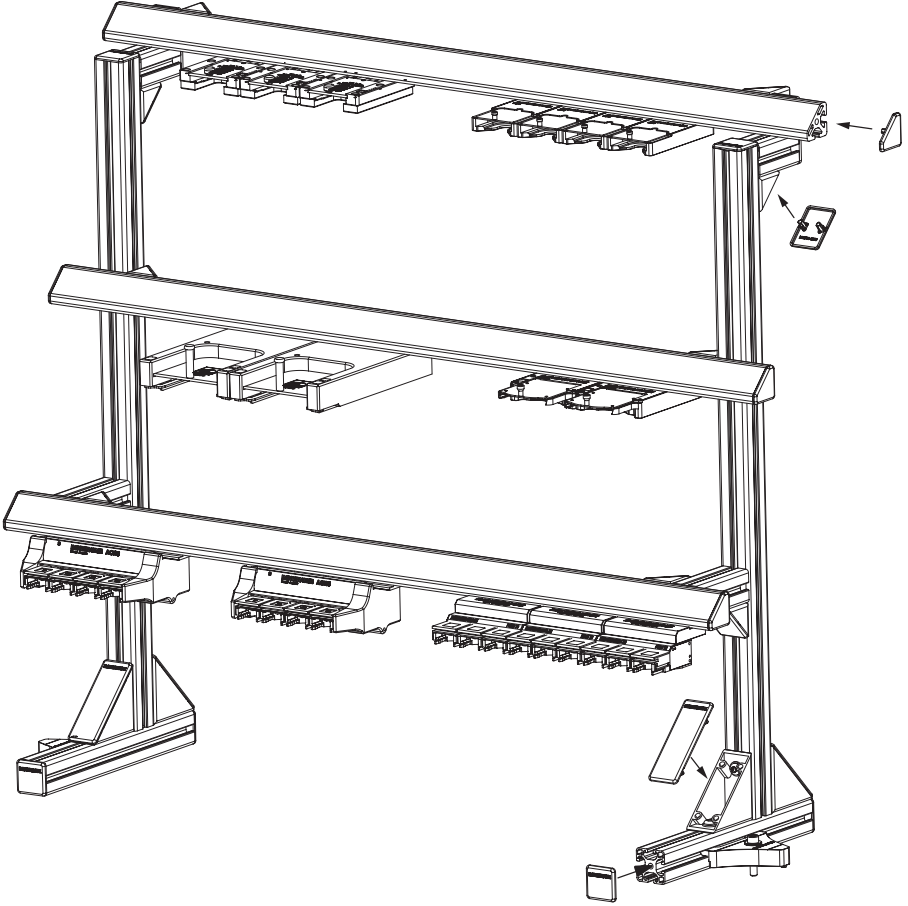
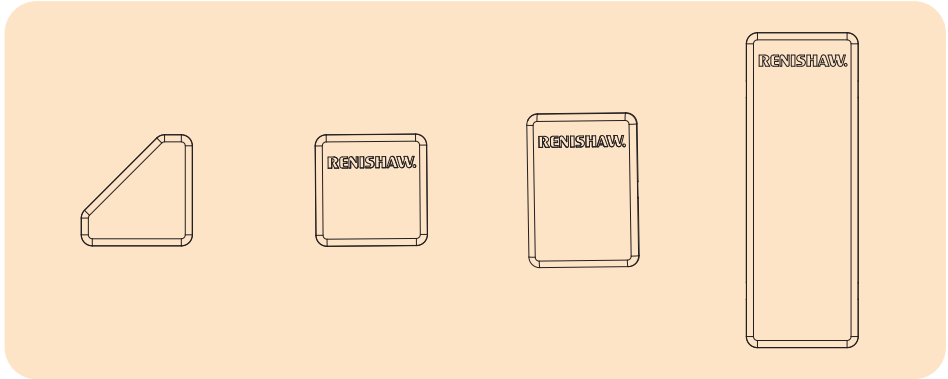

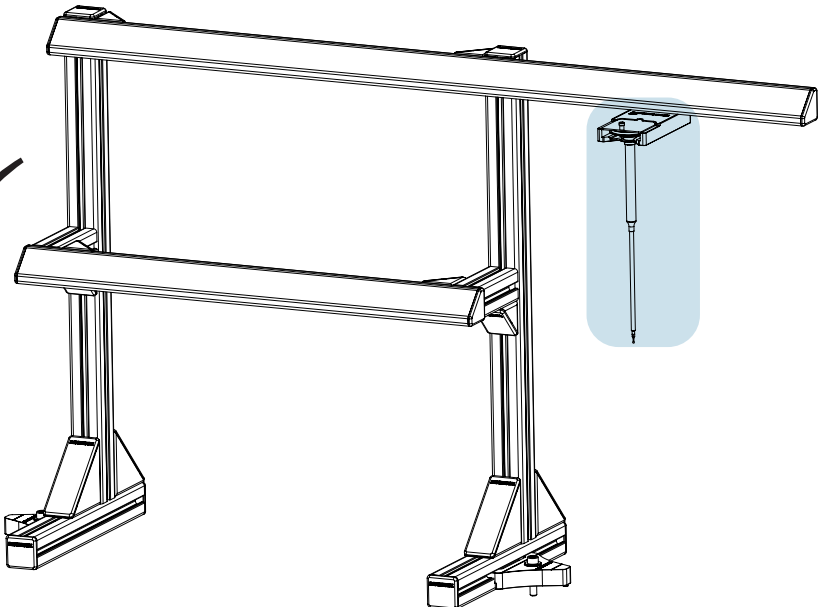
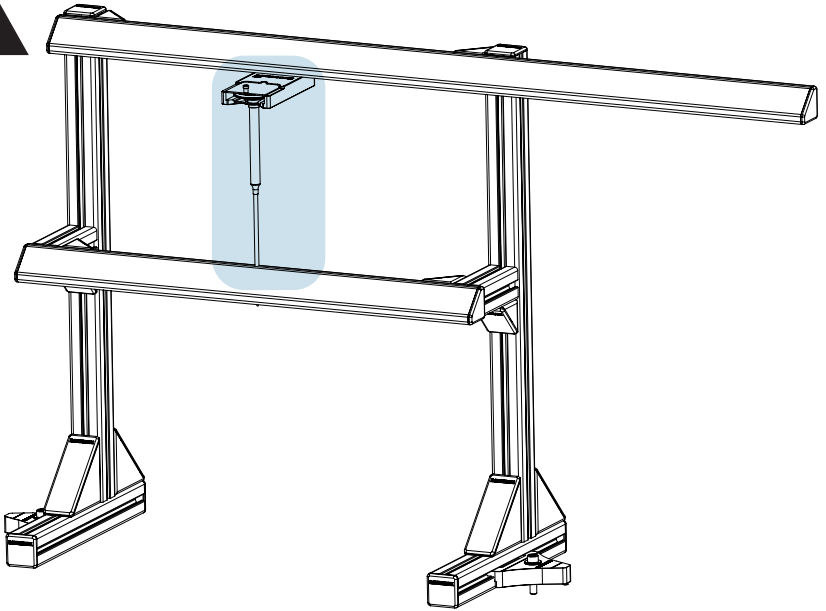

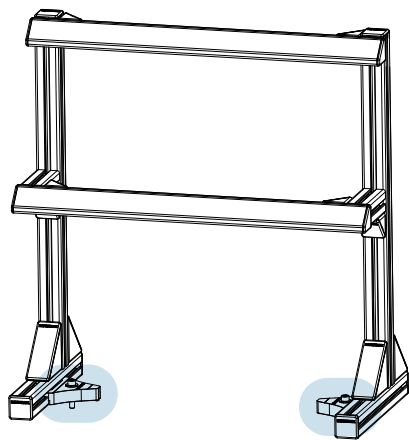
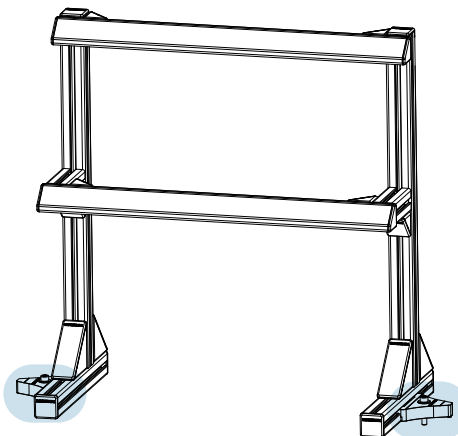
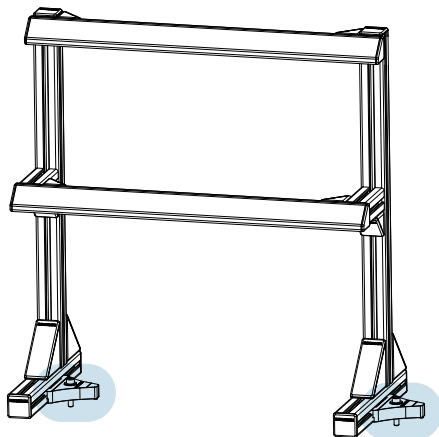

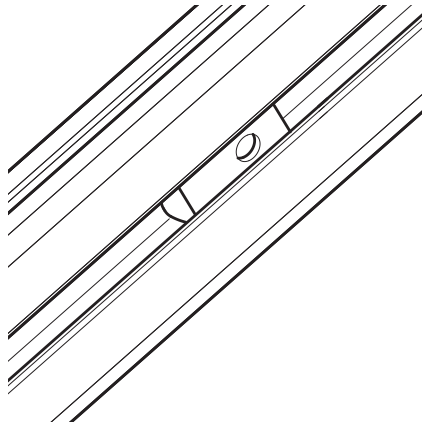
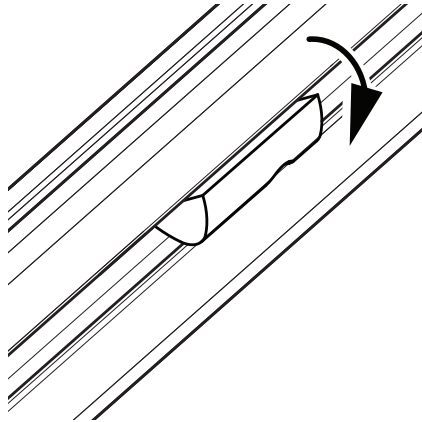
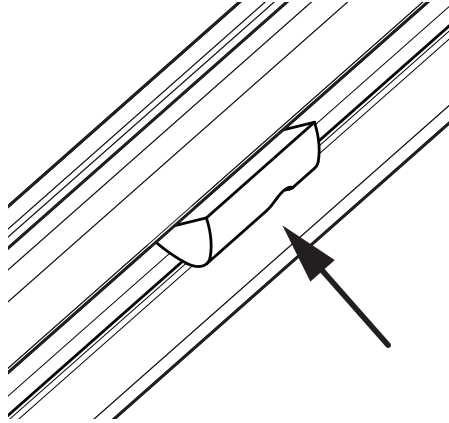

www.renishaw.com/MRS2

 #renishaw

 +48 22 577 11 80

 poland@renishaw.com

© 2015–2025 Renishaw plc. Wszelkie prawa zastrzeżone. Bez pisemnej zgody firmy Renishaw niniejszego dokumentu nie można w całości ani w części kopiować, powielać lub w jakikolwiek sposób inny przenosić na inny nośnik ani tłumaczyć na inne języki.

RENISHAW® i symbol sondy są zarejestrowanymi znakami towarowymi firmy Renishaw plc. Nazwy produktów Renishaw, oznaczenia i znak „apply innovation” są znakami towarowymi firmy Renishaw plc lub jej podmiotów zależnych. Inne nazwy marek, produktów i firm są znakami towarowymi odpowiednich właścicieli.

MIMO ŻE DOŁOŻONO WSZELKICH STARAŃ, ABY ZWERYFIKOWAĆ DOKŁADNOŚĆ NINIEJSZEGO DOKUMENTU W CHWILI JEGO PUBLIKACJI, W MAKSYMALNYM ZAKRESIE DOZWOLONYM PRZEZ PRZEPISY PRAWA WYŁĄCZA SIĘ WSZELKIE WYNIKAJĄCE Z NIEGO GWARANCJE, WARUNKI, OBJĘTNOŚĆ I ODPOWIEDZIALNOŚĆ PRAWNĄ. FIRMA RENISHAW ZASTRZĘGA PRAWO DO WPROWADZANIA ZMIAN W NINIEJSZYM DOKUMENCIE ORAZ W OPISANYCH W NIM URZĄDZENIACH, OPROGRAMOWANIU I DANYCH TECHNICZNYCH BEZ OBOWIĄZKU POWIADOMIENIA O TAKICH ZMIANACH.

Renishaw plc. Zarejestrowano w Anglii i Walii. Numer rejestracyjny spółki: 1106260. Siedziba: New Mills, Wotton-under-Edge, Glos, GL12 8JR, Wielka Brytania.

Nr katalogowy: H-1000-5473-03-B

Data wydania: 01.2025