

Stili per applicazioni ZEISS

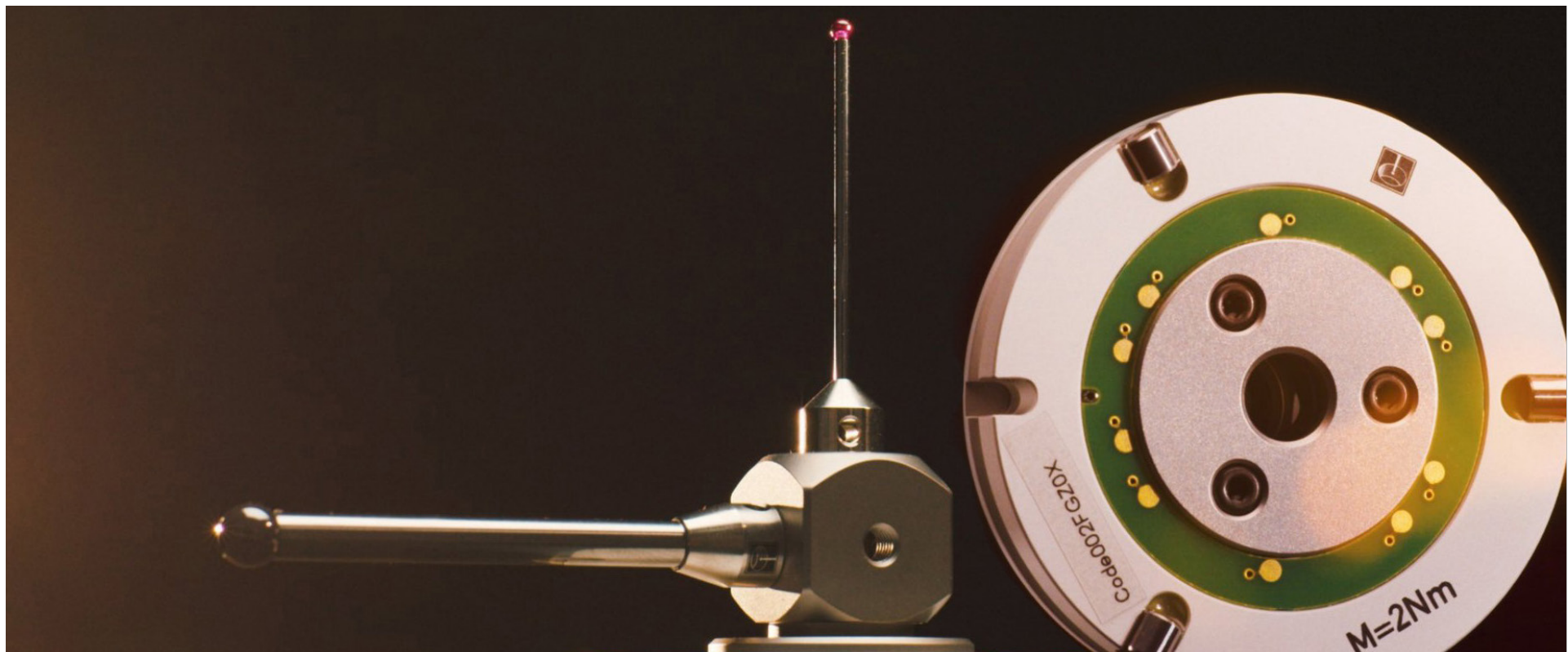

www.renishaw.com/shop/styli

#renishaw

Sommario

Stili M5 Renishaw, adattatori e accessori per sonde analogiche ZEISS	7
Stili in carburo	7
Stili per ScanMax	9
Stili in carburo di tungsteno con sfera in nitruro di silicio	10
Stili di riferimento (punto rosso)	11
Stili in fibra di carbonio termostabile	12
Stili in fibra di carbonio termostabile, con sfera in nitruro di silicio	13
Stili in ceramica	14
Stili con microsfele	15
Stili a stella (fissi)	16
Stili per configurazioni a stella, lunghezza filettatura 12,5 mm	17
Stili con filettatura lunga (5 mm)	18
Rondella piana per stili a stella	19
Rondella scanalata per stili a stella	19
Perno per stili a stella	19
Stili non filettati (per applicazioni con portastilo)	20
Portastilo a 5 vie	21
Portastilo a 90°	21
Adattatore a 90°	22
Portastilo orientabile	22
Stili per configurazioni orientabili	22
Stili a disco sferico	23
Stili a disco sferico ScanMax	23
Stili per la misura della filettatura	24
Stili a punta	24
Stili a stella	25

Disco sferico	26
Adattatore rotante	26
Snodo, angolo di oscillazione 180°	27
Snodo rotante, angolo di rotazione 360°, angolo di oscillazione 180°	27
Centro stella	27
Centro stella a 4 vie	28
Centro stella ad angolo	29
Doppio centro stella	30
Prolunga centro stella	30
Prolunghe	31
Calibro per misura filettatura	34
Vite per centro stella e disco sferico	34
Adattatore	35
Adattatore con base filettata/conica	35
Portastilo per stili di digitalizzazione	35
Chiave pin da 2,9	36
Sfera di calibrazione	36
Base magnetica per sfera di calibrazione	37
Piattelli Renishaw per teste ZEISS	38
Piattelli per sistemi di misura VAST/ MT	38
Piattello per sistemi dinamici (ST)	38
Piattello per sistemi dinamici Prismo (ST)	39
Prolunghe per piattelli	40
Stili M3 Renishaw, adattatori e accessori per sonde analogiche ZEISS	41
Stili in carburo XXT	41
Stili di riferimento XXT (punto rosso)	42
Stili in fibra di carbonio termostabile XXT	43
Stili in fibra di carbonio termostabile XXT con sfera in nitruro di silicio	44

Stili di fissaggio in fibra di carbonio termostabile XXT	44
Stili di fissaggio in fibra di carbonio termostabile XXT con sfera in nitruro di silicio	45
Stili in fibra di carbonio termostabile XXT per stili a stella da 1/4	45
Stili in fibra di carbonio per stili a stella da 1/4 in fibra di carbonio termostabile XXT con sfera in nitruro di silicio	46
Stili in fibra di carbonio termostabile XXT per stili a stella da 1/2	46
Stili in fibra di carbonio termostabile XXT a 90° per stili a stella da 1/2 con sfera in nitruro di silicio	47
Stili in fibra di carbonio termostabile XXT a 180° per stili a stella da 1/2	47
Stili in fibra di carbonio termostabile XXT a 180° per stili a stella da 1/2 con sfera in nitruro di silicio	48
Prolunghe in fibra di carbonio XXT	48
Piattello VAST XXT TL1	49
Piattello di riferimento VAST XXT TL1	49
Piattello VAST XXT TL1 con adattatore a stella	49
Piattello per XXT TL2	50
Piattello di riferimento per XXT TL2	50
Piattello VAST XXT TL3	50
Piattello di riferimento VAST XXT TL3	51
Piattello VAST XXT TL3 stella	51
Vite di fissaggio XXT	51
Vite di fissaggio XXT con filettatura interna M3	52
Centro stella XXT 90°, 1 via	52
Centro stella XXT 180°, 2 vie	52
Centro stella XXT stella	53
Centro stella XXT, stella a 6	53
Centro stella XXT, stella a 8	53
Snodo XXT	54
Stili in carburo	55
Stili in ceramica	56
Stili cilindrici	57

Prolunghe	58
Portastilo a 5 vie, rotante.....	58
Supporto per stili a 90°	58
Snodo rotante	59
Adattatore	59
Strumenti e accessori Renishaw per il montaggio di stili M2, M3 o M5 su teste di misura ZEISS.....	59
Utensile per stilo	59
Utensile per montaggio stilo	60
Chiavi a brugola	60
Stili M2 Renishaw, adattatori e accessori per sonde analogiche ZEISS	61
Stili in carburo	61
Stili in ceramica.....	62
Stili in acciaio inox.....	63
Stili a stella	63
Stili per configurazioni a stella.....	64
Stili a disco sferico	64
Stili a disco sferico	65
Stili cilindrici.....	65
Prolunga	66
Portastilo a 5 vie, rotante.....	66
Portastilo a 5 vie, piccolo/grande	67
Supporto per stili a 90°	67
Snodo rotante	67
Snodo rotante, angolo di rotazione 360°, angolo di oscillazione 180°	68

NOTA: Gli schemi mostrati non sono in scala.

Stili M5 Renishaw, adattatori e accessori per sonde analogiche ZEISS

Stili in carburo

Filettatura	M5
Base	Titanio
Stelo	Carburo di tungsteno
Diametro sfera fino a 12 mm	Rubino
Diametro sfera maggiore di 12 mm	Ceramica

Codice Renishaw	Numero di codice ZEISS	DK (mm)	ML1/ML (mm)	DG/D (mm)	L (mm)	DS1/DS (mm)	Peso (g)
A-5555-2388	–	1,0	10,0	11	20,0	0,8	6,0
A-5555-1495	–	1,0	20,0	11	30,0	0,8	6,0
A-5555-1679	–	1,0	5,0/10,0	11	20,0	0,8/1,0	6,0
A-5555-1054	–	1,0	5,0/15,0	11	25,0	0,8/1,0	6,0
A-5004-4166	–	1,0	5,0/20,0	11	30,0	0,8/1,0	6,0
A-5003-0145	–	1,5	8,0/20,0	11	30,0	1,0/1,5	6,0
A-5555-1077	–	2,0	10,0	11	20,0	1,0	6,0
A-5555-1563	–	2,0	15,0	11	25,0	1,0	6,0
A-5555-1060	–	2,0	20,0	11	30,0	1,5	7,0
A-5555-0952	–	2,0	30,0	11	40,0	1,5	7,0
A-5555-0018	602030-9010-000	3,0	15,0	11	25,0	2,0	4,0
A-5555-0019	600342-8020-000	3,0	23,5	11	33,5	2,0	4,5
A-5555-0020	602030-9011-000	3,0	40,0	11	50,0	2,0	5,2
A-5555-0021	600342-8021-000	3,0	48,0	11	58,0	2,0	5,5
A-5555-1508	–	3,5	48,0	11	58,0	2,0	6,0
A-5003-7499	–	3,5	65,0	11	75,0	2,5	6,5
A-5555-1425	–	3,5	85,0	11	100,0	2,5	7,0
A-5555-0974	–	4,0	20,0	11	30,0	2,0	4,4
A-5555-0022	600342-8025-000	4,0	23,5	11	33,5	2,0	4,5

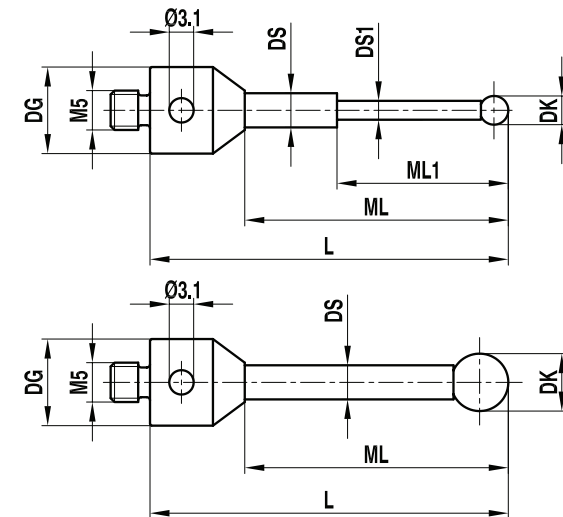

Codice Renishaw	Numero di codice ZEISS	DK (mm)	ML1/ML (mm)	DG/D (mm)	L (mm)	DS1/DS (mm)	Peso (g)
A-5555-0023	602030-9012-000	4,0	54,0	11	64,0	2,0	5,9
A-5555-0498	612030-9661-000	4,5	43,0	11	53,0	3,5	8,0
A-5555-0805	–	5,0	20,0	11	30,0	3,5	8,0
A-5555-0024	602030-9013-000	5,0	40,0	11	50,0	3,5	9,0
A-5555-0025	600342-8022-000	5,0	43,0	11	53,0	3,5	9,8
A-5555-0026	602030-9015-000	5,0	65,0	11	75,0	3,5	12,5
A-5555-1271	–	5	90,0	11	100,0	3,5	15,0
A-5555-0027	600342-8026-000	6	44,0	11	54,0	3,5	10,0
A-5555-0028	600342-8027-000	7	45,0	11	55,0	3,5	10,0
A-5555-0029	600342-8023-000	8	50,5	11	63,5	6,0	24,8
A-5555-0030	–	8	41,5	19	63,5	6,0	36,7
A-5555-0031	–	8	61,0	11	74,0	6,0	29,5
A-5555-0032	602030-9016-000	8	62,0	11	75,0	6,0	30,0
A-5555-0033	602030-9017-000	8	87,0	11	100,0	6,0	40,0
A-5555-0034	600342-8024-000	8	101,5	11	114,5	6,0	45,8
A-5555-0035	600342-8124-000	8	92,5	19	114,5	6,0	57,5
A-5555-0946	–	8	137,0	11	150,0	6,0	60,0
A-5555-1618	–	8	40,0	11	50,0	5,0	24,0
A-5555-0036	–	9	51,5	11	64,5	6,0	26,3
A-5555-0037	600342-8128-000	9	42,5	19	64,5	6,0	36,8
A-5555-0038	600342-8029-000	10	52,5	11	65,5	6,0	25,8
A-5555-0039	–	10	43,5	19	65,5	6,0	37,8
A-5555-0040	602030-9018-000	10	105,0	11	118,0	6,0	47,3
A-5555-2389	–	10	137,0	11	150,0	6,0	62,0
A-5555-2390	–	10	175,0	11	200,0	6,0	75,0
A-5555-2391	–	12	52,0	11	65,5	6,0	28,0
A-5555-1628	626115-1200-118	12	105,0	11	118,0	6,0	49,0
A-5555-2392	–	12	175,0	11	200,0	6,0	76,0
A-5555-2144	–	15	52,5	11	65,5	6,0	29,0
A-5555-2270	–	15	105,0	11	118,0	6,0	50,0
A-5555-2393	–	15	175,0	11	200,0	6,0	78,0

Stili per ScanMax

Filettatura	M5
Base	Acciaio inox
Stelo	Carburo di tungsteno
Sfera	Carburo di tungsteno

Codice Renishaw	Numero di codice ZEISS	DK (mm)	ML1/ML (mm)	DG/D (mm)	L (mm)	DS1/DS (mm)	Peso (g)
A-5555-2394	000000-1078-483	3	23,5	11	33,5	2	4,5
A-5555-3949	000000-1073-344	5	95,0	11	105	3,5	15,0
A-5555-2395	612030-9649-000	8	50,5	11	63,0	6,0	25,0

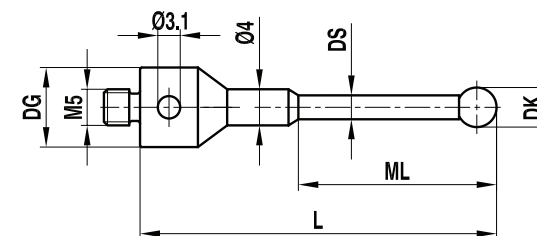

Stili in carburo di tungsteno con sfera in nitruro di silicio

Filettatura	M5
Base	Titanio
Stelo	Carburo di tungsteno
Sfera	Nitruro di silicio
Note supplementari	Montaggio su coppa

Codice Renishaw	Numero di codice ZEISS	DK (mm)	ML1/ML (mm)	DG/D (mm)	L (mm)	DS1/DS (mm)	Peso (g)
A-5555-3777	–	1,0	5,0/10,0	11	20,0	0,8/1,0	3,5
A-5555-3778	–	1,0	5,0/15,0	11	25,0	0,8/1,0	3,5
A-5555-3779	–	1,0	5,0/20,0	11	30,0	0,8/1,0	3,8
A-5555-3780	–	1,5	8,0/20,0	11	30,0	1,0/1,5	3,5
A-5555-3781	–	2,0	10,0	11	20,0	1,0	3,5
A-5555-3782	–	2,0	15,0	11	25,0	1,0	3,5
A-5555-3783	–	2,0	20,0	11	30,0	1,5	3,8
A-5555-3784	–	2,0	30,0	11	40,0	1,5	4,0
A-5555-3785	626115-0303-025	3,0	15,0	11	25,0	2,0	4,0
A-5555-3786	–	3,0	23,5	11	33,5	2,0	4,5
A-5555-3787	626115-0302-050	3,0	40,0	11	50,0	2,0	5,3
A-5555-3734	626115-0300-058	3,0	48,0	11	58,0	2,0	5,5
A-5555-3788	626115-0400-034	4,0	23,5	11	33,5	2,0	4,5
A-5555-3789	–	4,0	54,0	11	64,0	2,0	5,9
A-5555-3790	–	5,0	20,0	11	30,0	3,5	8,0
A-5555-3791	626115-0501-050	5,0	40,0	11	50,0	3,5	9,0
A-5555-3792	–	5,0	43,0	11	53,0	3,5	9,8
A-5555-3793	626115-0500-075	5,0	65,0	11	75,0	3,5	12,5
A-5555-3794	626115-0501-100	5,0	90,0	11	100,0	3,5	18,0
A-5555-3795	–	6,0	44,0	11	54,0	3,5	10,0
A-5555-3796	–	7,0	45,0	11	55,0	3,5	10,0
A-5555-3797	626115-0800-064	8,0	50,5	11	63,5	6,0	36,6
A-5555-3798	626115-0800-075	8,0	62,0	11	75,0	6,0	29,4

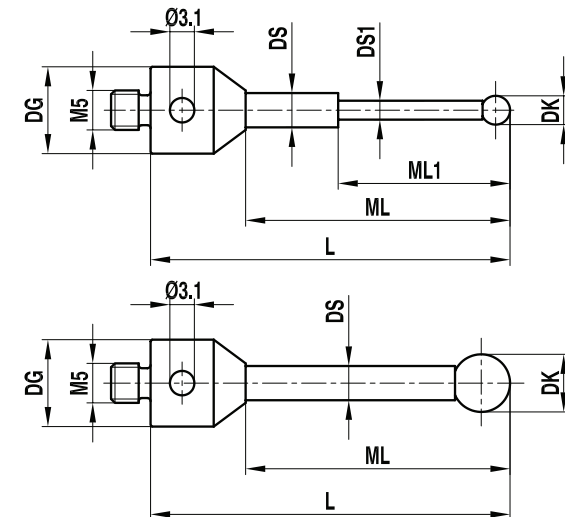

Codice Renishaw	Numero di codice ZEISS	DK (mm)	ML1/ML (mm)	DG/D (mm)	L (mm)	DS1/DS (mm)	Peso (g)
A-5555-3799	–	8,0	87,0	11	100,0	6,0	39,9
A-5555-3800	626115-0800-115	8,0	101,5	11	114,5	6,0	45,7
A-5555-3801	–	9,0	51,5	11	64,5	6,0	26,3
A-5555-3802	–	10,0	52,5	11	65,5	6,0	25,8
A-5555-3803	–	10,0	105,0	11	118	6,0	47,3
A-5555-3804	–	10,0	135,0	11	150,0	6,0	60,0

Stili di riferimento (punto rosso)

Filettatura	M5
Base	Acciaio inox
Stelo	Acciaio inox
Sfera	Rubino

Codice Renishaw	Numero di codice ZEISS	DK (mm)	ML1/ML (mm)	DG/D (mm)	L (mm)	DS1 DS (mm)	Peso (g)
A-5555-3805	600342-8023-010	8	50,5	11	63,5	6,0	24,8

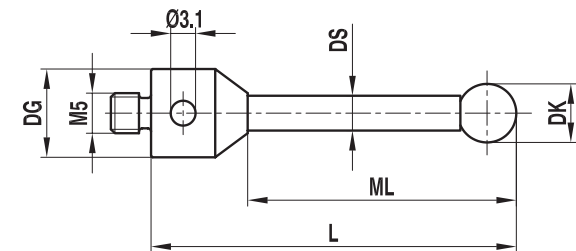

Stili in fibra di carbonio termostabile

Filettatura	M5
Base	Titanio
Stelo	Fibra di carbonio
Sfera	Rubino
Note supplementari	Termostabile e montato su perno

Codice Renishaw	Numero di codice ZEISS	DK (mm)	ML1/ML (mm)	DG/D (mm)	L (mm)	DS1/DS (mm)	Peso (g)
A-5555-1916	626105-0300-025	3	15,0	11	25,0	2	4,0
A-5555-1847	626105-0300-033	3	23,5	11	33,5	2	4,2
A-5555-0730	626105-0300-050	3	40,0	11	50,0	2	4,5
A-5555-3806	626105-0300-058	3	48,0	11	58,0	2	4,9
A-5555-1917	626105-0400-033	4	23,5	11	33,5	2	4,2
A-5555-0731	626105-0400-064	4	54,0	11	64,0	2	4,6
A-5555-0732	626105-0510-050	5	40,0	11	50,0	3,5	4,8
A-5555-2013	–	5	43,0	11	53,0	3,5	4,9
A-5555-0735	626105-0510-075	5	65,0	11	75,0	3,5	5,0
A-5555-0410	626105-0510-100	5	90,0	11	100,0	3,5	5,4
A-5555-0733	626105-0610-054	6	44,0	11	54,0	3,5	4,9
A-5555-0734	626105-0710-055	7	45,0	11	55,0	3,5	4,9
A-5555-3807	626105-0820-063	8	50,5	11	63,5	6	7,0
A-5555-3997	626105-0820-075	8	62,0	11	75,0	6	7,3
A-5555-1918	626105-0820-100	8	87,0	11	100,0	6	7,5
A-5555-3808	626105-0820-114	8	101,5	11	114,5	6	9,5
A-5555-9361	626105-0820-150	8	137,0	11	150,0	6	11
A-5555-1112	626105-0820-200	8	187,0	11	200,0	6	13
A-5555-3809	–	9	51,5	11	64,5	6	7,2
A-5555-1027	626105-1020-065	10	52,5	11	65,5	6	8,0

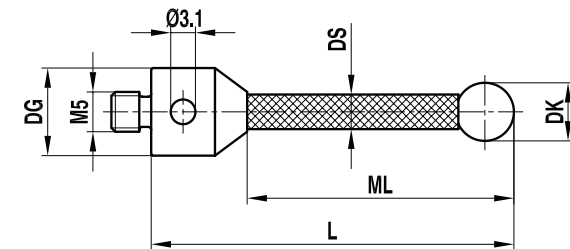

Codice Renishaw	Numero di codice ZEISS	DK (mm)	ML1/ML (mm)	DG/D (mm)	L (mm)	DS1/DS (mm)	Peso (g)
A-5555-3998	626105-1020-118	10	105,0	11	118,0	6	14,5
A-5555-0643	626105-1020-150	10	137,0	11	150,0	6	16,0
A-5555-0644	626105-1020-200	10	187,0	11	200,0	6	19,0

Stili in fibra di carbonio termostabile, con sfera in nitruro di silicio

Filettatura	M5
Base	Titanio
Stelo	Fibra di carbonio
Sfera	Nitruro di silicio
Note supplementari	Montaggio su perno fino a 6 mm di diametro

Codice Renishaw	Numero di codice ZEISS	DK (mm)	ML1/ML (mm)	DG/D (mm)	L (mm)	DS1/DS (mm)	Peso (g)
A-5555-3812	626105-0301-025	3	15,0	11	25,0	2	4,0
A-5555-1828	626105-0301-033	3	23,5	11	33,5	2	4,2
A-5555-3813	626105-0301-050	3	40,0	11	5,00	2	4,5
A-5555-3814	626105-0301-058	3	48,0	11	58,0	2	4,9
A-5555-3815	626105-0301-033	4	23,5	11	33,5	2	4,2
A-5555-2396	626105-0401-064	4	54,0	11	64,0	2	4,6
A-5555-3817	626105-0511-050	5	40,0	11	50,0	3,5	4,8
A-5555-2397	–	5	43,0	11	53,0	3,5	4,9
A-5555-2012	626105-0511-075	5	65,0	11	75,0	3,5	5,0
A-5555-1065	626105-0511-100	5	90,0	11	100,0	3,5	5,4
A-5555-2398	–	6	44,0	11	54,0	3,5	4,9
A-5555-2399	–	7	45,0	11	55,0	3,5	4,9
A-5555-0720	626105-0821-063	8	50,5	11	63,5	6	7,0
A-5555-2400	–	8	62,0	11	75,0	6	7,3
A-5555-3820	626105-0821-100	8	87,0	11	100,0	6	7,5
A-5555-3821	626105-0821-114	8	101,5	11	114,5	6	9,5

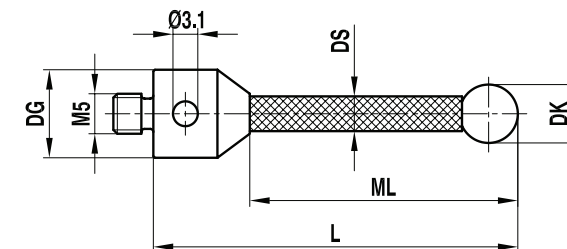

Codice Renishaw	Numero di codice ZEISS	DK (mm)	ML1/ML (mm)	DG/D (mm)	L (mm)	DS1/DS (mm)	Peso (g)
A-5555-1169	626105-0821-150	8	137,0	11	150,0	6	11,0
A-5555-1179	626105-0821-200	8	187,0	11	200,0	6	13,0
A-5555-2402	–	9	51,5	11	64,5	6	7,2
A-5555-2403	626105-1021-065	10	52,5	11	65,5	6	8,0
A-5555-3824	626105-1021-118	10	105,0	11	118,0	6	14,5
A-5555-3825	626105-1021-150	10	137,0	11	150,0	6	16,0
A-5555-1171	626105-1021-200	10	187,0	11	200,0	6	19,0

Stili in ceramica

Filettatura	M5
Base	Titanio
Stelo	Ceramica
Sfera	Rubino
Note supplementari	Montaggio su coppa

Codice Renishaw	Numero di codice ZEISS	DK (mm)	ML1/ML (mm)	DG/D (mm)	L (mm)	DS1/DS (mm)	EAL/B (mm)	Peso (g)
A-5555-0041	600342-8013-000	5	43,0	11	53,0	3,5		4,6
A-5555-0042	600342-8016-000	6	44,0	11	54,0	3,5		4,7
A-5555-0043	600342-8017-000	7	45,0	11	55,0	3,5		5,0
A-5555-0044	600342-8014-000	8	50,5	11	63,5	6,0		8,3
A-5555-0049	–	8	41,5	19	63,5	6,0		33,0
A-5555-0050	600342-8015-000	8	101,5	11	114,5	6,0		11,8
A-5555-0051	–	8	92,5	19	114,5	6,0		38,0
A-5555-0045	600342-8018-000	9	51,5	11	64,5	6,0		8,4
A-5555-0046	–	9	42,5	19	64,5	6,0		21,0
A-5555-0047	600342-8019-000	10	52,5	11	65,5	6,0		9,0
A-5555-0048	–	10	43,5	19	65,5	6,0		38,0

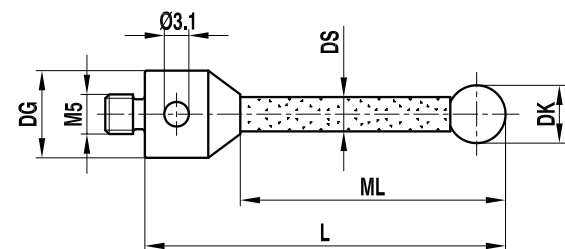

Stili con microsfera

Filettatura	M5
Base	Acciaio inox
Stelo	Carburo di tungsteno
Sfera	Rubino
Note supplementari	Montaggio su perno a eccezione di sfere con diametro compreso fra 0,2 e 0,6 mm

Codice Renishaw	Numero di codice ZEISS	DK (mm)	ML1/ML (mm)	DG/D (mm)	L (mm)	DS1/DS (mm)	Peso (g)
A-5555-2404	-	0,2	2,3/12,0	11	32	0,18/1,0	6,5
A-5555-2405	-	0,25	2,3/12,0	11	32	0,18/1,0	6,5
A-5555-2407	-	0,3	2,3/12,0	11	32	0,2/1,0	6,5
A-5555-1773	-	0,5	2,5/12,0	11	32	0,3/1,0	6,5
A-5555-1095	000000-1120-407	0,6	4,6/12,0	11	32	0,4/1,0	6,5
A-5555-0052	602030-8060-000	0,8	4,8/12,0	11	32	0,6/1,0	6,8
A-5555-0053	602030-8061-000	1,0	5,0/12,0	11	32	0,8/1,0	6,8
A-5555-0054	602030-8062-000	1,35	12,0	11	32	1,0	6,9
A-5555-0055	602030-8063-000	1,35	19,0	11	44	1,0	7,5
A-5555-0056	602030-8064-000	1,5	12,0	11	32	1,0	6,5
A-5555-0057	602030-8065-000	1,5	19,0	11	44	1,0	7,5
A-5555-0058	602030-8066-000	2,0	12,0	11	32	1,5	7,3
A-5555-0059	602030-8067-000	2,0	19,0	11	44	1,5	8,0
A-5555-0060	602030-8068-000	2,0	33,0	11	58	1,5	8,0
A-5555-0061	602030-8069-000	2,5	12,0	11	32	1,5	7,3
A-5555-0062	602030-8070-000	2,5	19,0	11	44	1,5	8,0
A-5555-0063	602030-8071-000	2,5	33,0	11	58	1,5	8,0

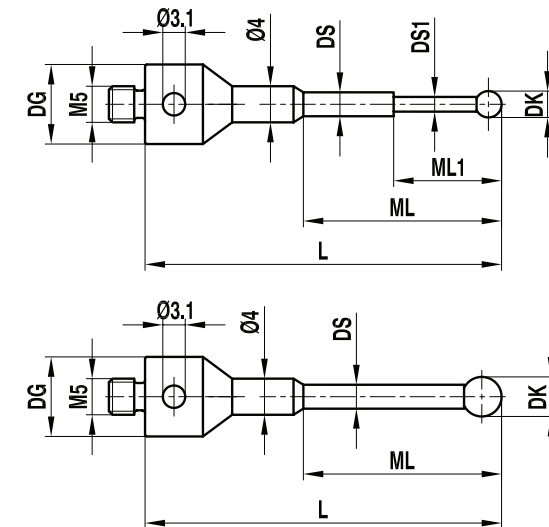

Filettatura	M5
Base	Titanio (conico)
Stelo	Carburo di tungsteno
Sfera	Rubino
Note supplementari	Montaggio su perno

Codice Renishaw	Numero di codice ZEISS	DK (mm)	ML1/ML (mm)	DG/D (mm)	L (mm)	DS1/DS (mm)	Peso (g)
A-5555-0064	602030-9019-000	1,0	5	11	55	0,8	11,9
A-5555-0065	602030-9020-000	1,5	5	11	55	1,0	11,9
A-5555-0066	602030-9021-000	2,0	5	11	55	1,5	11,9
A-5555-0067	–	2,5	5	11	55	2,0	11,9
A-5555-0068	602030-9023-000	3,5	10	11	55	2,5	11,9

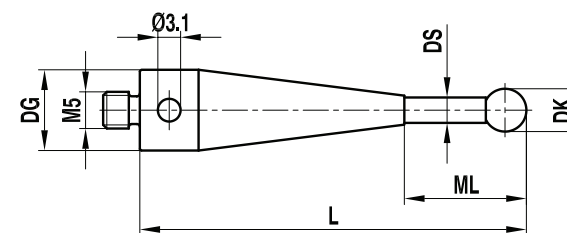

Stili a stella (fissi)

Filettatura	M5
Base	Titanio
Stelo	Carburo di tungsteno
Sfera	Rubino

Codice Renishaw	Numero di codice ZEISS	DK (mm)	ML1/ML (mm)	DG/D (mm)	L (mm)	DS1/DS (mm)	EAL/B (mm)	Peso (g)
A-5555-0069	–	1,0	7,0		45	0,8/2,0	15	17,3
A-5555-0070	602030-9025-000	1,5	7,5		45	1,0/2,0	15	17,3
A-5555-0071	–	2,0	7,5		45	1,5/2,0	15	17,3
A-5555-0072	602030-9027-000	2,5	8,0		45	1,5/2,0	15	17,3
A-5555-0073	–	3,5	15,0		45	2,0	15	17,3

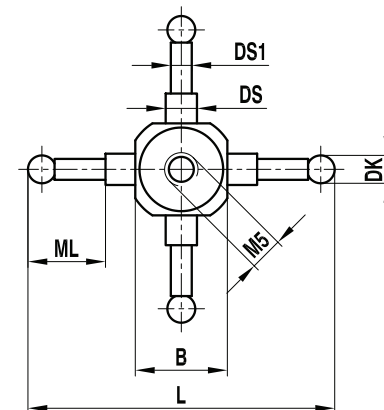

Stili per configurazioni a stella, lunghezza filettatura 12,5 mm

Filettatura	M5
Base	Acciaio inox
Stelo	Carburo di tungsteno
Sfera	Rubino
Note supplementari	Montaggio su perno a eccezione di sfere con diametro compreso fra 0,3 e- 0,6 mm

Codice Renishaw	Numero di codice ZEISS	DK (mm)	ML1/ML (mm)	DG/D (mm)	L (mm)	DS1/DS (mm)	Peso (g)
A-5555-0084	600342-8250-000	0,3	2,3/12,8	11	21,8	0,2/1,0	6
A-5555-0085	600342-8251-000	0,5	2,5/13,0	11	22,0	0,3/1,0	6
A-5555-0086	600342-8252-000	0,6	4,6/13,1	11	22,1	0,4/1,0	6
A-5555-0087	600342-8253-000	0,8	4,8/13,3	11	22,3	0,6/1,0	6
A-5555-0088	600342-8254-000	1,0	5,0/13,5	11	22,5	0,8/1,0	6
A-5555-0078	600342-8200-000	1,35	23,85	11	32,85	1,0	6
A-5555-0079	600342-8201-000	1,5	24,0	11	33,0	1,0	7
A-5555-0080	600342-8202-000	2,0	24,5	11	33,5	1,5	7
A-5555-0081	600342-8203-000	2,5	25,0	11	34,0	1,5	7
A-5555-2408	-	3,0	16,5	11	25,5	2,0	7
A-5555-0082	600342-8221-000	3,0	16,5	19	34,5	2,0	20
A-5555-2409	-	5,0	25,5	11	34,5	3,5	9
A-5555-0083	600342-8222-000	5,0	25,5	19	43,5	3,5	23

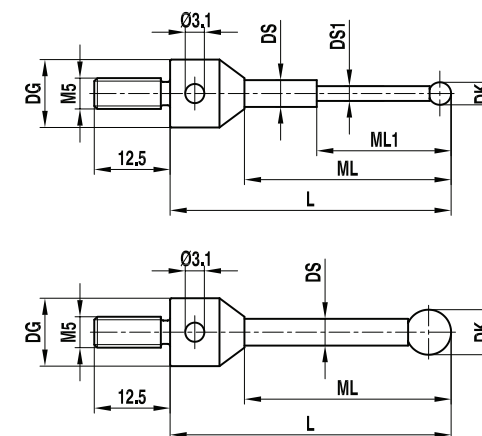

Stili con filettatura lunga (5 mm)

Filettatura	M5
Base	Acciaio inox
Stelo	Carburo di tungsteno
Sfera	Rubino
Note supplementari	Montaggio su perno a eccezione di sfere con diametro compreso fra 0,3– 0,6 mm

Codice Renishaw	Numero di codice ZEISS	DK (mm)	ML1/ML (mm)	DG/D (mm)	L (mm)	DS1/DS (mm)	Peso (g)
A-5555-0331	626115-0030-022	0,3	2,3/12,8	11	21,8	0,2/1,0	6
A-5555-1157	626115-0050-022	0,5	2,5/13,0	11	22,0	0,3/1,0	6
A-5555-1842	626115-0060-022	0,6	4,6/13,1	11	22,1	0,4/1,0	6
A-5555-1844	626115-0080-022	0,8	4,8/13,3	11	22,3	0,6/1,0	6
A-5555-1843	626115-0100-022	1,0	5,0/13,5	11	22,5	0,8/1,0	6
A-5555-0799	626115-0140-033	1,35	23,85	11	32,85	1,0	6
A-5555-0329	626115-0150-033	1,5	24,0	11	33,0	1,0	7
A-5555-0965	–	1,5	7,0/24,0	11	33,0	1,0/1,5	7
A-5555-3826	–	2,0	24,5	11	33,5	1,0	7
A-5555-9325	626115-0200-034	2,0	24,5	11	33,5	1,5	7
A-5555-3827	–	2,5	25,0	11	34,0	1,0	7
A-5555-0686	626115-0250-034	2,5	25,0	11	34,0	1,5	7
A-5555-3828	–	3,0	16,5	11	25,5	2,0	9
A-5555-2444	–	5,0	25,5	11	34,5	3,5	9

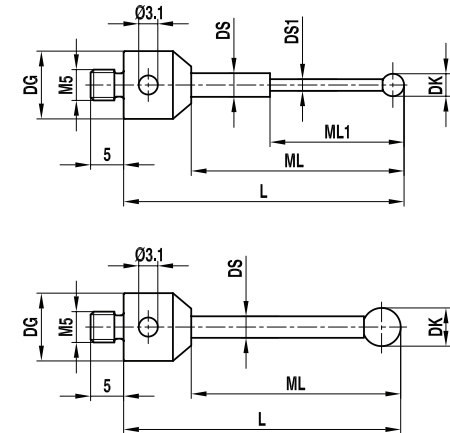

Rondella piana per stili a stella

Filettatura	M5
Rondella	Acciaio inox

Codice Renishaw	Numero di codice ZEISS	DG/D (mm)	EAL/B (mm)	Peso (g)
A-5555-0089	600341-0140-000	11	1,5	1
A-5555-0090	600341-0141-000	19	2,0	4

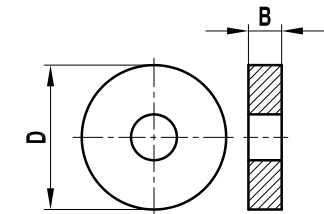

Rondella scanalata per stili a stella

Filettatura	M5
Rondella	Acciaio inox

Codice Renishaw	Numero di codice ZEISS	DG/D (mm)	EAL/B (mm)	Peso (g)
A-5555-0091	600341-0150-000	11	2	1
A-5555-0092	600341-0151-000	19	4	7

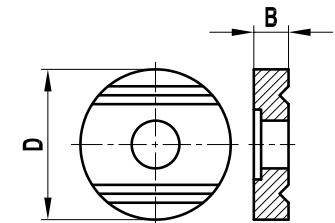

Perno per stili a stella

Filettatura	M5
Pin	Carburo di tungsteno

Codice Renishaw	Numero di codice ZEISS	DG/D (mm)	L (mm)	Peso (g)
A-5555-0093	600341-0520-000	1,0	10	1
A-5555-0094	600341-0521-000	1,5	10	1
A-5555-0095	600341-0522-000	2,0	18	1
A-5555-0096	600341-0523-000	3,5	18	3

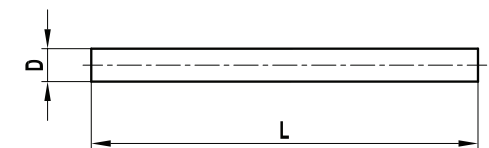

Stili non filettati (per applicazioni con portastilo)

Stelo	Carburo di tungsteno
Sfera	Rubino
Note supplementari	Montaggio su perno a eccezione di sfere con diametro compreso fra 0,2 e 0,6 mm

Codice Renishaw	Numero di codice ZEISS	DK (mm)	ML1/ML (mm)	L (mm)	DS1/DS (mm)	Peso (g)
A-5555-1141	–	0,2	2,3	15,2	0,18/1,0	1
A-5555-2410	–	0,25	2,35	15,25	0,18/1,0	1
A-5555-0108	600341-8450-000	0,3	2,3	15,3	0,2/1,0	1
A-5555-2411	–	0,4	2,5	15,4	0,3/1,0	1
A-5555-0109	600341-8451-000	0,5	2,5	15,5	0,3/1,0	1
A-5555-0110	600341-8452-000	0,6	4,6	15,6	0,4/1,0	1
A-5555-1277	–	0,7	4,6	15,7	0,4/1,0	1
A-5555-0111	600341-8453-000	0,8	4,8	15,8	0,6/1,0	1
A-5555-0107	600341-8454-000	1,0	5,0	16,0	0,8/1,0	1
A-5555-0112	600341-8500-000	1,35	–	26,35	1,0	1
A-5555-0113	600341-8501-000	1,5	–	26,5	1,0	1
A-5555-2412	–	2,0	–	27,0	1,0	1
A-5555-0114	600341-8502-000	2,0	–	27,0	1,5	1
A-5555-2413	–	2,5	–	27,5	1,0	1
A-5555-0115	600341-8503-000	2,5	–	27,5	1,5	1
A-5555-0116	600341-8510-000	3,0	–	38,0	2,0	2
A-5555-0117	600341-8511-000	5,0	–	45,0	3,5	6

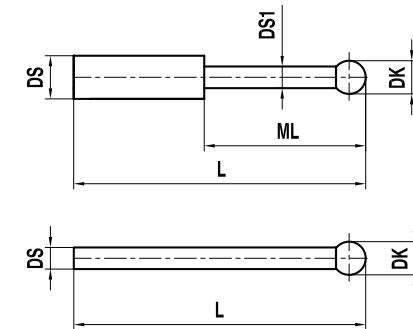

Portastilo a 5 vie

Filettatura	M5
Supporto	Acciaio inox

Codice Renishaw	Numero di codice ZEISS	DG/D (mm)	L (mm)	DS1/DS (mm)	Peso (g)
A-5555-0105	600341-8367-000	11	10	1,0	3,2
A-5555-0106	600341-8368-000	11	10	1,5	3,2
A-5555-1245	626115-5000-199	11	10	2,0	3,2

NOTA: adatto per stili A-5555-0116 (vedere “Stili non filettati (per applicazioni con portastilo)” a pag. 20)

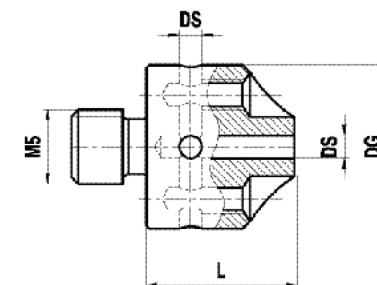

Portastilo a 90°

Filettatura	M5
Pin	Carburo di tungsteno

Codice Renishaw	Numero di codice ZEISS	DG/D (mm)	L (mm)	DS1/DS (mm)	Peso (g)
A-5555-0104	600341-8160-000	11	45	1-1,5/6	16

NOTA: adatto per stili A-5555-0116 (vedere “Stili non filettati (per applicazioni con portastilo)” a pag. 20)

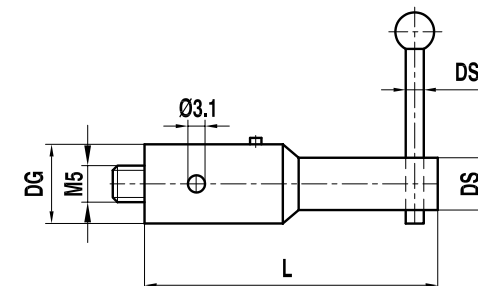

Adattatore a 90°

Filettatura	M5
Angolo	Titanio

Codice Renishaw	Numero di codice ZEISS	ML1/ML (mm)	DG/D (mm)	L (mm)	Peso (g)
A-5555-1097	626105-6901-001	17	11	22,5	6

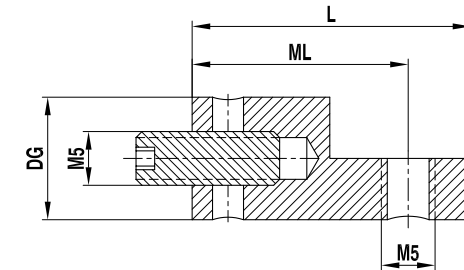

Portastilo orientabile

Filettatura	M5
Supporto	Acciaio inox

Codice Renishaw	Numero di codice ZEISS	DG/D (mm)	L (mm)	DS1/DS (mm)	Peso (g)
A-5555-0118	600341-8180-000	11	40	1-1,5/6	15

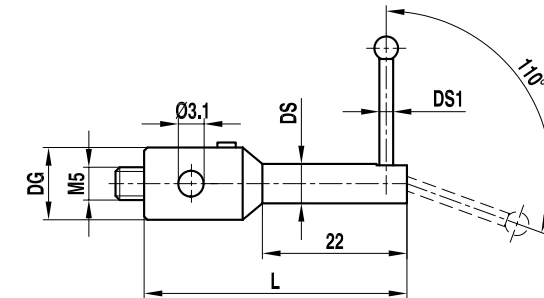

Stili per configurazioni orientabili

Filettatura	M5
Sfera S4	Acciaio
Stelo	Carburo di tungsteno
Sfera	Rubino
Note supplementari	Montaggio su perno

Codice Renishaw	Numero di codice ZEISS	DK (mm)	ML1/ML (mm)	DG/D (mm)	L (mm)	DS1/DS (mm)	Peso (g)
A-5555-0119	600341-8183-000	1	5,0	1,0	17,5	0,8/1,0	1
A-5555-0120	600341-8185-000	2	24,5	1,5	28,5	1,5	1

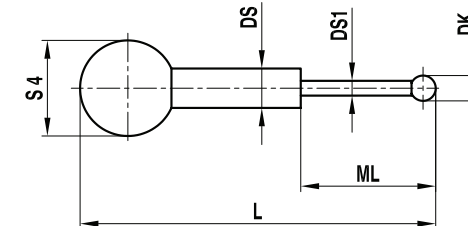

Stili a disco sferico

Filettatura	M5
Base	Alluminio
Disco	Acciaio

Codice Renishaw	Numero di codice ZEISS	DK (mm)	DG/D (mm)	L (mm)	EAL/B (mm)	Peso (g)
A-5555-0121	600341-8090-000	10	7	21,5	1,5	3
A-5555-0122	600341-8095-000	15	10	21,5	1,5	6
A-5555-0124	000000-1165-629	15	7	40,0	1,0	5
A-5555-0123	602030-8091-000	20	7	60,0	1,0	8

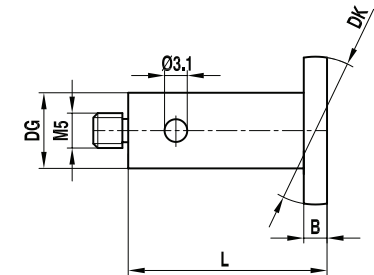

Stili a disco sferico ScanMax

Filettatura	M5
Base	Titanio
Disco	Acciaio

Codice Renishaw	Numero di codice ZEISS	DK (mm)	ML1/ML (mm)	DG/D (mm)	L (mm)	DS1/DS (mm)	EAL/B (mm)	Peso (g)
A-5555-2415	632001-8209-000	10	55	11	65	3,5/5,5	1	11
A-5555-2416	626115-1505-065	15	55	11	65	3,5/5,5	1	18
A-5555-2417	632001-8207-000	20	55	11	65	3,5/5,5	1	19
A-5555-2418	632001-8208-000	25	55	11	65	3,5/10,0	1	22
A-5555-2419	632001-8210-000	30	55	11	65	3,5/10,0	2	39
A-5555-2420	632001-8213-000	40	55	11	65	3,5/10,0	2	57
A-5555-2421	000000-1019-819	10	55	11	65	3,5/5,5	2	17
A-5555-2422	000000-1019-820	15	55	11	65	3,5/5,5	2	20
A-5555-2423	000000-1019-822	20	55	11	65	3,5/5,5	2	25
A-5555-2424	000000-1019-824	25	55	11	65	3,5/10,0	2	32

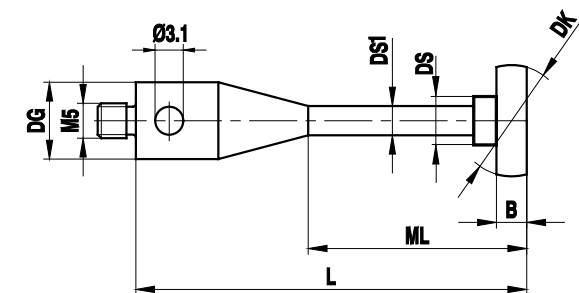

Stili per la misura della filettatura

Filettatura	M5
Base	Acciaio inox
Stelo	Carburo di tungsteno
Sfera	Rubino
Note supplementari	Montaggio su perno a eccezione di sfere con diametro 0,5 mm

Codice Renishaw	Numero di codice ZEISS	DK (mm)	ML1/ML (mm)	DG/D (mm)	L (mm)	DS1/DS (mm)	EAL/B (mm)	Peso (g)
A-5555-3999	-	0,5	3,5	11	40	0,4	1,9	7
A-5555-0077	-	0,8	5	11	40	0,6	1,9	7
A-5555-0074	-	1,35	9	11	40	1,0	2,0	11
A-5555-0076	-	1,8	10	11	40	1,0	2,0	12
A-5555-0075	-	2,3	12	11	40	1,0	2,5	13

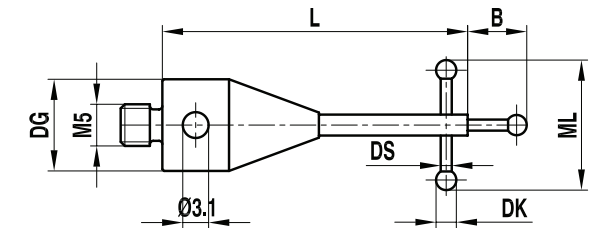

Stili a punta

Filettatura	M5
Base	Titanio
Stelo	Carburo di tungsteno

Codice Renishaw	Numero di codice ZEISS	DK (mm)	ML1/ML (mm)	DG/D (mm)	L (mm)	DS1/DS (mm)	Peso (g)
A-5555-0216	600342-8051-000	30°	39	11	61	3,5	12

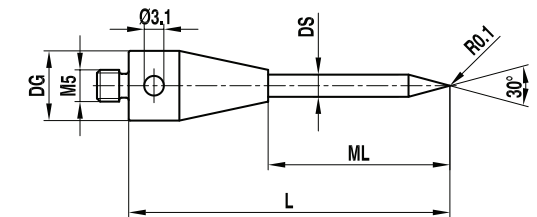

Stili a stella

Filettatura	M5
Base	Alluminio
Stelo	Carburo di tungsteno
Sfera	Rubino
Note supplementari	Montaggio su perno

Codice Renishaw	Numero di codice ZEISS	DK (mm)	DG/D (mm)	L (mm)	DS1/DS (mm)	Peso (g)
A-5555-0215	600331-8093-000	5	19	80	3,5	70

Filettatura	M5
Base	Acciaio inox
Stelo	Carburo di tungsteno
Sfera	Rubino
Note supplementari	Termostabile e montato su perno a eccezione delle sfere con diametro 0,6

Codice Renishaw	Numero di codice ZEISS	DK (mm)	ML1/ML (mm)	DG/D (mm)	L (mm)	DS1/DS (mm)	A (mm)	Peso (g)
A-5555-1153	–	0,6	30	11	40	0,4/4,0	8	9
A-5555-1135	–	0,8	30	11	40	0,6/4,0	8	9
A-5555-3839	–	1,0	30	11	40	0,8/4,0	8	9

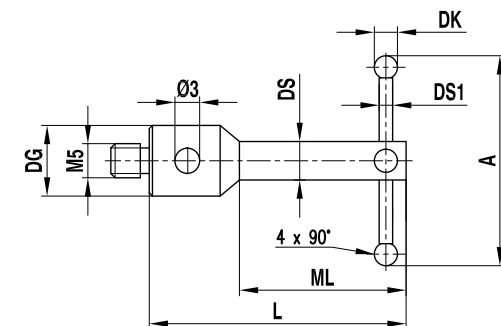
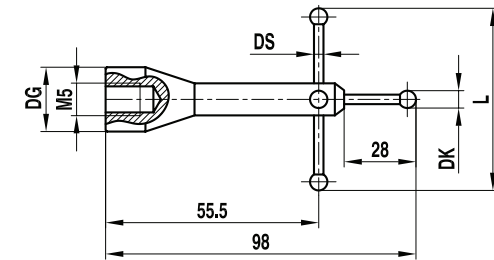

Disco sferico

Filettatura	M5
Disco	Acciaio inox

Codice Renishaw	Numero di codice ZEISS	DK (mm)	Filettatura/foro (mm)	EAL/B (mm)	Peso (g)
A-5555-0196	602030-0004-000	15	M5	4	5
A-5555-0197	602030-0005-000	20	M5	4	9
A-5555-0198	602030-0006-000	30	M5	4	21
A-5555-0199	602030-0007-000	40	M5	5	42
A-5555-0200	602030-0008-000	50	M5	5	64
A-5555-0201	602030-0009-000	60	M5	5	89
A-5555-0203	602030-0011-000	20	8	4	8
A-5555-0204	600341-0200-000	20	8	2	4
A-5555-0205	600341-0203-000	30	8	4	10
A-5555-0206	600341-0204-000	40	8	4	21
A-5555-0207	600341-0205-000	50	8	5	36
A-5555-0208	600341-0206-000	60	8	6	59

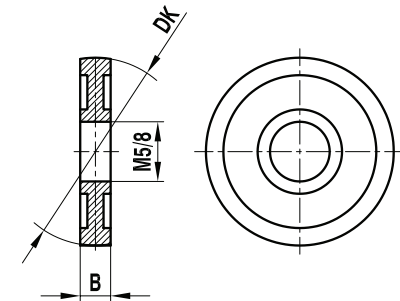

Adattatore rotante

Filettatura	M5
Adattatore	Titanio

Codice Renishaw	Numero di codice ZEISS	DG/D (mm)	L (mm)	Peso (g)
A-5555-0713	-	11	29	13
A-5555-0099	-	18	30	43

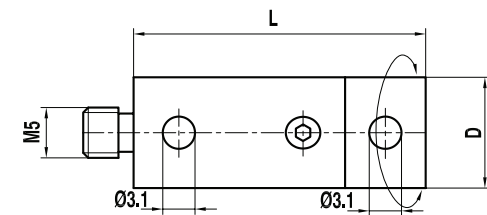

Snodo, angolo di oscillazione 180°

Filettatura	M5
Snodo	Titanio

Codice Renishaw	Numero di codice ZEISS	DG/D (mm)	L (mm)	Peso (g)
A-5555-0218	600342-9002-000	11	30	11,2
A-5555-0219	–	18	36	37,2

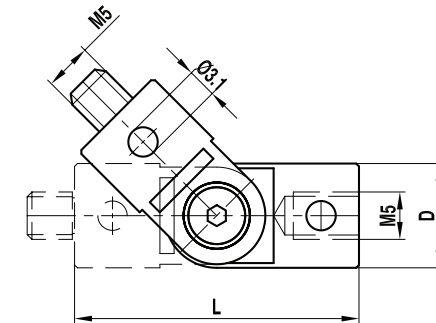

Snodo rotante, angolo di rotazione 360°, angolo di oscillazione 180°

Filettatura	M5
Snodo	Titanio

Codice Renishaw	Numero di codice ZEISS	DG/D (mm)	L (mm)	Peso (g)
A-5555-1093	–	11	51	19
A-5555-3841	–	18	58	58

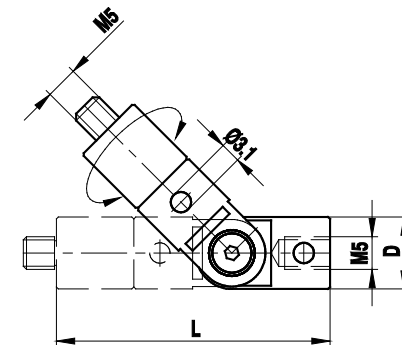

Centro stella

Filettatura	M5
Centro stella	Titanio

Codice Renishaw	Numero di codice ZEISS	EAL/B (mm)	Peso (g)
A-5555-0189	600341-8361-000	15	12,6
A-5555-1478*	626115-6110-001	15	12,6
A-5555-0190	600341-8002-000	20	31,5
A-5004-2109*	626115-6110-003	20	31,5

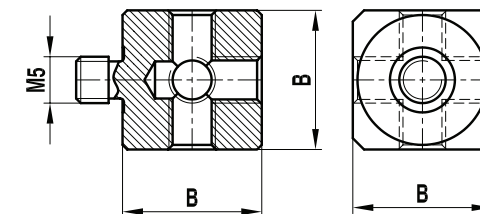

NOTA: Set di viti in dotazione.

Filettatura	M5
Centro stella	Alluminio

Codice Renishaw	Numero di codice ZEISS	EAL/B (mm)	Peso (g)
A-5555-0191	602030-8363-000	15	7,5
A-5555-0192	602030-8362-000	20	20,0

Filettatura	M5
Centro stella	Titanio

Codice Renishaw	Numero di codice ZEISS	EAL/B (mm)	Peso (g)
A-5555-1892	626115-6110-002	15	13

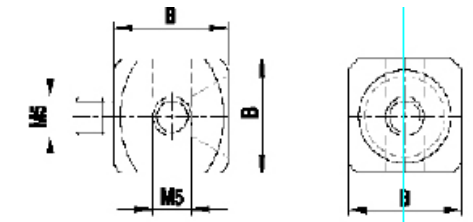
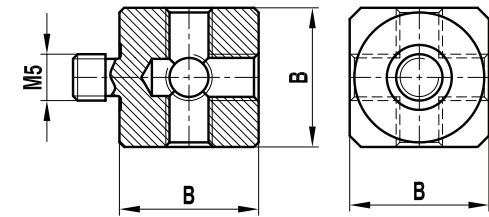

Centro stella a 4 vie

Filettatura	M5
Centro stella	Titanio

Codice Renishaw	Numero di codice ZEISS	EAL/B (mm)	Peso (g)
A-5555-1551	-	15	13

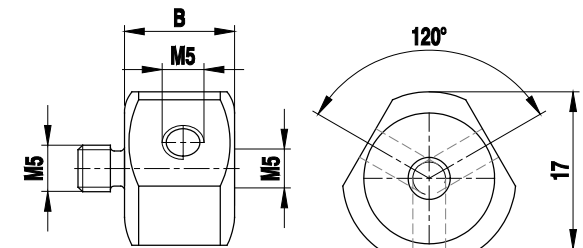

Centro stella ad angolo

Filettatura	M5
Centro stella	Titanio

Codice Renishaw	Numero di codice ZEISS	W (°)	EAL/B (mm)	Peso (g)
A-5555-2425	–	87,5	15	13,0
A-5555-2426	–	85,0	15	13,4
A-5555-2427	–	82,5	15	13,8
A-5555-2428	–	80,0	15	14,2
A-5555-2429	–	77,5	15	14,6
A-5555-2430	–	75,0	15	15,0
A-5555-2431	–	72,5	15	15,4
A-5555-2432	–	70,0	15	15,8
A-5555-2433	–	67,5	15	16,2
A-5555-2434	–	65,0	15	16,6
A-5555-2435	–	62,5	15	17,0
A-5555-2436	–	60,0	15	17,4
A-5555-2437	–	57,5	15	17,8
A-5555-2438	–	55,0	15	18,2
A-5555-2439	–	52,5	15	18,6
A-5555-2440	–	50,0	15	19,0
A-5555-2441	–	47,5	15	19,4
A-5555-2442	–	45,0	15	19,8

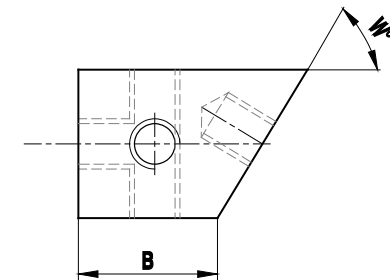

Doppio centro stella

Filettatura	M5
Centro stella	Titanio

Codice Renishaw	Numero di codice ZEISS	L (mm)	EAL/B (mm)	Peso (g)
A-5555-0194	–	40	20	64

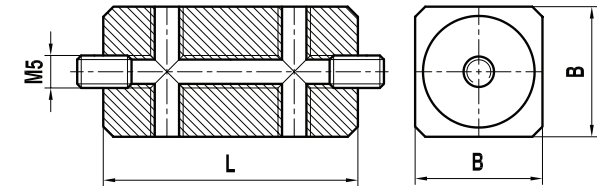

Prolunga centro stella

Filettatura	M5
Centro stella	Titanio

Codice Renishaw	Numero di codice ZEISS	L (mm)	EAL/B (mm)	Peso (g)
A-5555-0217	–	120	20	87

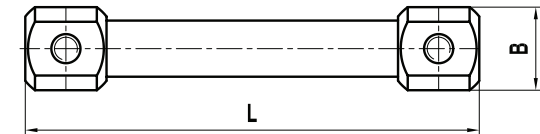

Prolunghe

Filettatura	M5
Prolunga	Titanio

Codice Renishaw	Numero di codice ZEISS	DG/D (mm)	L (mm)	Peso (g)
A-5555-0143	602030-9044-000	11	10	3,6
A-5555-0144	602030-9045-000	11	15	5,7
A-5555-0145	602030-9046-000	11	20	7,8
A-5555-0146	602030-9047-000	11	25	9,7
A-5555-0950	000000-1251-674	11	30	12,1
A-5555-0619	—	11	35	13,9
A-5555-0148	602030-9049-000	11	40	16,1
A-5555-0150	602030-9051-000	11	50	12,7
A-5555-0152	602030-9053-000	11	60	13,6
A-5555-0154	602030-9055-000	11	75	15,0
A-5555-0156	602030-9057-000	11	80	15,6
A-5555-0158	602030-9059-000	11	90	16,2
A-5555-0160	602030-9061-000	11	100	17,3
A-5555-0162	602030-9063-000	11	120	19,4
A-5555-0164	602030-9065-000	11	150	22,4
A-5555-0147	602030-9048-000	18	25	27,3
A-5555-0149	602030-9050-000	18	40	44,7
A-5555-0151	602030-9052-000	18	50	36,3
A-5555-0153	602030-9054-000	18	60	38,3
A-5555-0155	602030-9056-000	18	75	42,8
A-5555-0157	602030-9058-000	18	80	44,2
A-5555-0159	602030-9060-000	18	90	47,3
A-5555-0161	602030-9062-000	18	100	49,4
A-5555-0163	602030-9064-000	18	120	55,1
A-5555-0165	602030-9066-000	18	150	65,0

Codice Renishaw	Numero di codice ZEISS	DG/D (mm)	L (mm)	Peso (g)
A-5555-0166	602030-9067-000	18	200	79,3
A-5555-0167	602030-9068-000	18	250	92,4
A-5555-0168	602030-9069-000	18	300	107,0

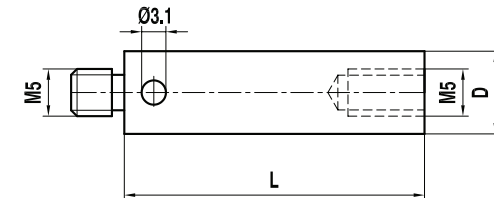

Filettatura	M5
Prolunga	Fibra di carbonio termostabile, estremità in titanio

Codice Renishaw	Numero di codice ZEISS	DG/D (mm)	L (mm)	Peso (g)
A-5555-0647	626107-1040-100	11	40	9
A-5555-0648	626107-1050-100	11	50	10
A-5555-0649	626107-1060-100	11	60	11
A-5555-0623	626107-1070-100	11	70	11
A-5555-0650	626107-1080-100	11	80	12
A-5555-0651	626107-1090-100	11	90	13
A-5555-0652	626107-1100-100	11	100	14
A-5555-0425	626107-1120-100	11	120	15
A-5555-0424	626107-1150-100	11	150	17
A-5555-0653	626107-1180-100	11	180	19
A-5555-0654	626107-1200-100	11	200	21
A-5555-0655	626107-1250-100	11	250	24
A-5555-0642	626107-1300-100	11	300	27
A-5555-0656	626107-1400-100	11	400	34
A-5555-0620	626107-2040-100	20	40	26
A-5555-0657	626107-2050-100	20	50	28
A-5555-0658	626107-2060-100	20	60	29
A-5555-0621	626107-2080-100	20	80	32
A-5555-0659	626107-2100-100	20	100	34
A-5555-0660	626107-2120-100	20	120	37
A-5555-0661	626107-2150-100	20	150	41
A-5555-0662	626107-2180-100	20	180	45
A-5555-0663	626107-2200-100	20	200	48
A-5555-0427	626107-2250-100	20	250	55
A-5555-0664	626107-2300-100	20	300	62
A-5555-0665	626107-2400-100	20	400	75
A-5555-0667	626107-2500-100	20	500	89
A-5555-0668	626107-2600-100	20	600	103

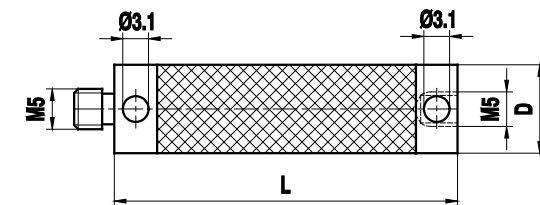

Filettatura	M5
Prolunga	Alluminio, estremità in acciaio inox

Codice Renishaw	Numero di codice ZEISS	DG/D (mm)	L (mm)	Peso (g)
A-5003-0850	–	11	20	5,7
A-5555-0135	600341-8261-000	11	40	10,3
A-5555-0134	600341-8262-000	11	60	15,4
A-5555-0133	600341-8263-000	11	80	20,6
A-5555-0132	600341-8264-000	11	100	25,6
A-5555-0131	600341-8265-000	11	120	30,9
A-5555-0130	600341-8425-000	20	40	29,0
A-5555-0671	–	20	50	33,3
A-5555-0129	600341-8424-000	20	60	37,7
A-5555-0128	600341-8423-000	20	80	44,8
A-5555-0127	600341-8422-000	20	100	50,7
A-5555-0126	600341-8421-000	20	150	67,4
A-5555-0125	600341-8420-000	20	200	84,7

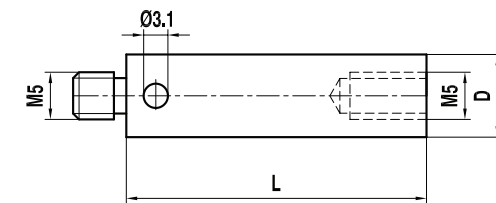

Filettatura	M5
Prolunga	Acciaio inox

Codice Renishaw	Numero di codice ZEISS	DG/D (mm)	L (mm)	Peso (g)
A-5555-0142	600341-0250-000	11	10	6
A-5555-0141	600341-0251-000	11	15	9
A-5555-0140	600341-0252-000	11	20	13
A-5555-0139	600341-0254-000	11	40	28
A-5555-0138	600341-0256-000	11	60	42
A-5555-0137	600341-0258-000	11	80	58
A-5555-0136	600341-0260-000	11	100	73

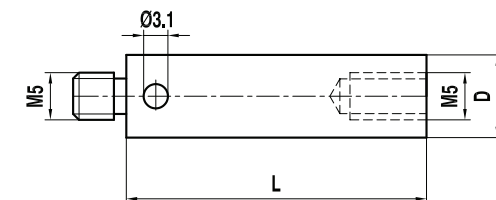

Calibro per misura filettatura

Filettatura	M5
Calibro	Acciaio inox

Codice Renishaw	Numero di codice ZEISS	ML1/ML (mm)	DG/D (mm)	L (mm)	MB (mm)	G1 (mm)	Peso (g)
A-5555-0209	–	10	10	16	1,8	M4	4
A-5555-0210	–	10	10	16	1,8	M5	4
A-5555-0211	–	12	12	18	1,8	M6	7
A-5555-0212	–	12	15	20	3,0	M8	13
A-5555-0213	–	15	18	25	3,0	M10	25
A-5555-0214	–	15	20	25	3,0	M12	33

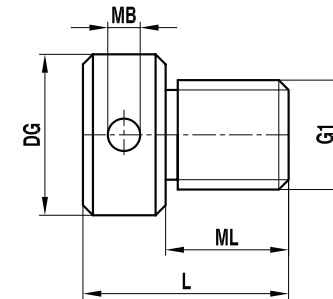

Vite per centro stella e disco sferico

Filettatura	M5
Prolunga	Fibra di carbonio termostabile, estremità in titanio

Codice Renishaw	Numero di codice ZEISS	ML1/ML (mm)	L (mm)	Peso (g)
A-5555-0223	600341-0212	9	17,5	7
A-5555-0222	600341-0211	21	30,0	9
A-5555-0221	600341-0210	26	35,0	9
A-5555-0225	–	21	–	3
A-5555-0224	–	26	–	4

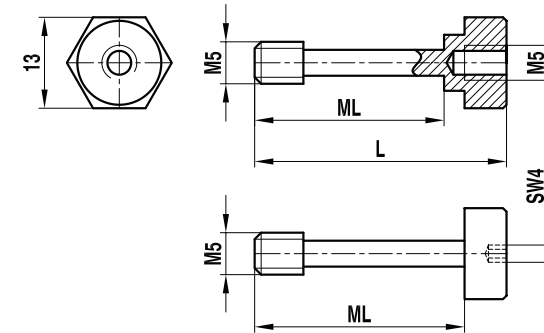

Adattatore

Filettatura	M5
Adattatore	Acciaio inox

Codice Renishaw	Numero di codice ZEISS	DG/D (mm)	L (mm)	Da/a (mm)	Peso (g)
A-5555-0226	602030-0215-000	11	10	M5/M2	5,2
A-5555-0227	602030-0315-000	11	10	M5/M3	5,2
A-5555-0228	–	11	10	M5/M4	5,2

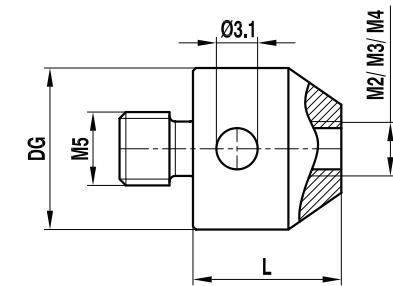

Adattatore con base filettata/conica

Filettatura	M5
Adattatore	Acciaio inox

Codice Renishaw	Numero di codice ZEISS	DG/D (mm)	L (mm)	Peso (g)
A-5555-0013	600331-0001-000	18	10	12
A-5555-0014	602030-0018-000	18	12	10

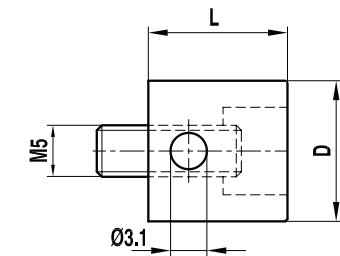
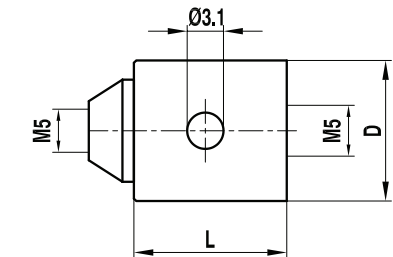

Portastilo per stili di digitalizzazione

Filettatura	M5
Supporto	Acciaio inox

Codice Renishaw	Numero di codice ZEISS	DG/D (mm)	L (mm)	Filettatura (mm)	Peso (g)
A-5555-0231	–	15,81	119	M2	126
A-5555-0232	602030-9115-000	9,52	127	M2	87

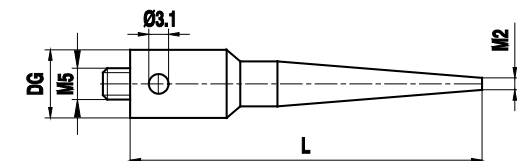

Chiave pin da 2,9

Filettatura	M5
Chiave inglese	Acciaio inox

Codice Renishaw	Numero di codice ZEISS	DG/ (mm)	L (mm)	Quantità
A-5555-0240	602030-0222-000	2,9	70	1
A-5555-0238	600341-8596-000	2,9	70	2

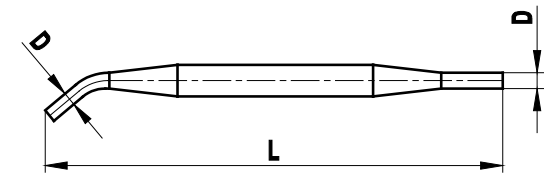

Sfera di calibrazione

Filettatura	M8
Materiale	Acciaio inox
Sfera	Ceramica
Note supplementari	Include un certificato interno

Codice Renishaw	Numero di codice ZEISS	DK (mm)	DG/D (mm)	L (mm)	SW (mm)
A-5555-3842	-	15	24	130	22
A-5555-3843	-	20	24	135	22
A-5555-3844	-	25	24	140	22
A-1034-0124	-	30	24	145	22

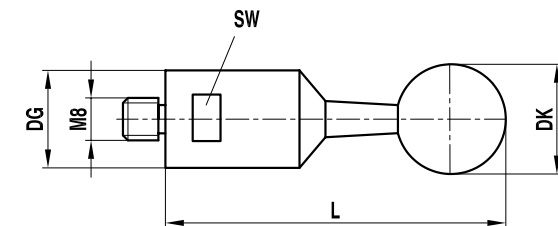

Base magnetica per sfera di calibrazione

Filettatura	M8
Note supplementari	Per calibrazioni inferiori a 45°

Codice Renishaw	Numero di codice ZEISS
A-5555-2443	—

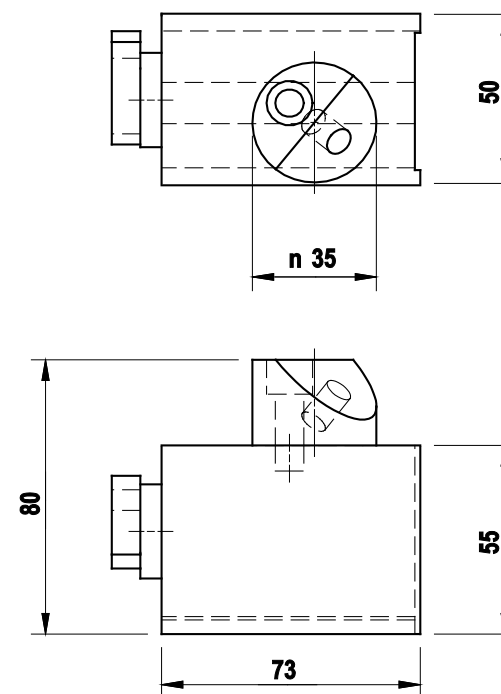

Piattelli Renishaw per teste ZEISS

Piattelli per sistemi di misura VAST/ MT

Filettatura	M5
Materiale	Alluminio
Note supplementari	Con chip ID attivo e riga da 15° incisa

Codice Renishaw	Numero di codice ZEISS	Numero di pezzi	Peso (g)
A-5555-0255	600667-9601-000	1	153
A-5555-0256	600667-9611-000	2	306
*A-5555-0258	626107-2000-940	1	130

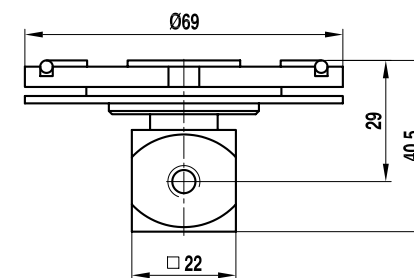

NOTA: * piattello adattatore al posto del centro stella.

Piattello per sistemi dinamici (ST)

Filettatura	M5
Materiale	Alluminio

Codice Renishaw	Numero di codice ZEISS	Numero di pezzi	Peso (g)
A-5555-0322	–	1	72
A-5555-0251	600660-8251-000	2	144

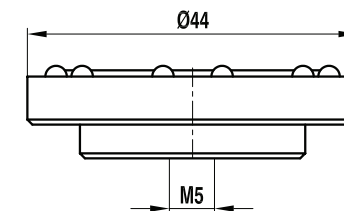

Piattello per sistemi dinamici Prismo (ST)

Filettatura	M5
Materiale	Alluminio

Codice Renishaw	Numero di codice ZEISS	Numero di pezzi	Peso (g)
A-5555-3900	-	1	72
A-5555-0253	620660-8251-000	2	144

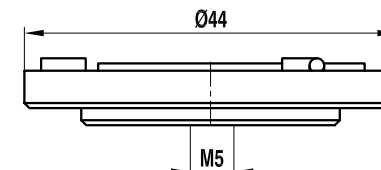

Prolunghe per piattelli

Filettatura	M5
Materiale	Fibra di carbonio termostabile
Centro stella e piattello	Titanio

Codice Renishaw	Numero di codice ZEISS	ML1/ML (mm)	DG/D (mm)	L (mm)	EAL/B (mm)	Peso (g)
A-5555-3845	–	66,5	11	25	15	60
A-5555-3846	–	81,5	11	40	15	62
A-5555-3847	–	91,5	11	50	15	64
A-5555-3848	–	101,5	11	60	15	66
A-5555-3849	–	121,5	11	80	15	68
A-5555-3850	–	141,5	11	100	15	70
A-5555-3851	–	161,5	11	120	15	72
A-5555-3740	–	191,5	11	150	15	77
A-5555-3852	–	241,5	11	200	15	84
A-5555-0699	626107-2025-130	66,5	20	25	15	60
A-5555-1985	626107-2040-130	81,5	20	40	15	62
A-5555-1986	626107-2050-130	91,5	20	50	15	64
A-5555-1987	626107-2060-130	101,5	20	60	15	66
A-5555-0700	626107-2080-130	121,5	20	80	15	68
A-5555-1988	626107-2100-130	141,5	20	100	15	70
A-5555-1989	626107-2120-130	161,5	20	120	15	72
A-5555-0701	626107-2150-130	191,5	20	150	15	77
A-5555-1990	626107-2200-130	241,5	20	200	15	84
A-5555-1979	626107-2025-110	71,5	20	25	20	74
A-5555-1980	626107-2040-110	86,5	20	40	20	76
A-5555-1855	626107-2050-110	96,5	20	50	20	78
A-5555-1981	626107-2060-110	106,5	20	60	20	80
A-5555-1982	626107-2080-110	126,5	20	80	20	82
A-5555-1983	626107-2100-110	146,5	20	100	20	84
A-5555-1938	626107-2120-110	166,5	20	120	20	86
A-5555-1937	626107-2150-110	196,5	20	150	20	91
A-5555-1984	626107-2200-110	246,5	20	200	20	98

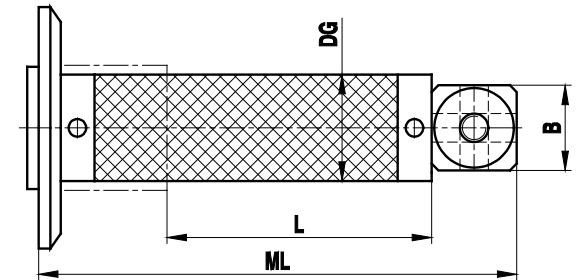
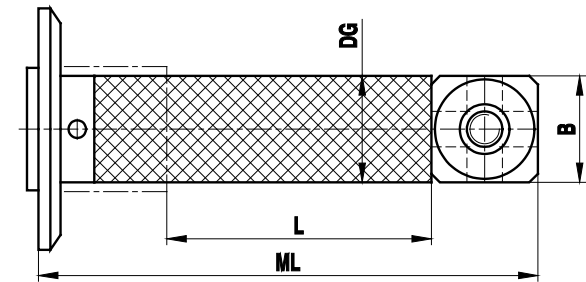

Stili M3 Renishaw, adattatori e accessori per sonde analogiche ZEISS

Stili in carburo XXT

Filettatura	M3
Base	Titanio
Stelo	Carburo di tungsteno
Sfera	Rubino
Note supplementari	Montaggio su perno a eccezione di sfere con diametro compreso fra 0,3 e- 0,6 mm

Codice Renishaw	Numero di codice ZEISS	DK (mm)	ML1/ML (mm)	DG/D (mm)	L (mm)	DS1/DS (mm)	Peso (g)
A-5004-3176	626113-0030-013	0,3	2,3/4,0	5	13	0,2/1,0	0,62
A-5004-2185	626113-0030-020	0,3	2,3/11	5	20	0,2/1,0	0,69
A-5004-1702	626113-0050-013	0,5	2,3/4,0	5	13	0,3/1,0	0,61
A-5004-2186	626113-0050-020	0,5	2,3/11	5	20	0,3/1,0	0,69
A-5555-3853	626113-0060-014	0,6	4,6/5,0	5	14	0,4/1,0	0,61
A-5004-3179	626113-0060-020	0,6	4,6/11,0	5	20	0,4/1,0	0,68
A-5004-3273	626113-0080-014	0,8	5,0	5	14	0,6	0,62
A-5004-3274	626113-0080-020	0,8	4,8/11,0	5	20	0,6/1,0	0,69
A-5004-1883	626113-0080-034	0,8	4,1/25,0	5	34	0,6/1,0	0,8
A-5004-3187	626113-0100-014	1,0	5,0	5	14	0,8	0,63
A-5555-3854	626113-0101-020	1,0	5,1/11,0	5	20	0,6/1,0	0,7
A-5004-1863	626113-0100-020	1,0	5,0/11,0	5	20	0,8/1,0	0,69
A-5004-3519	626113-0103-020	1,0	11,0	5	20	0,8	0,7
A-5004-3427	626113-0100-030	1,0	5,0/21,0	5	30	0,8/1,0	0,8
A-5555-9341	626113-0100-040	1,0	5,0/31,0	5	40	0,8/1,0	1,5

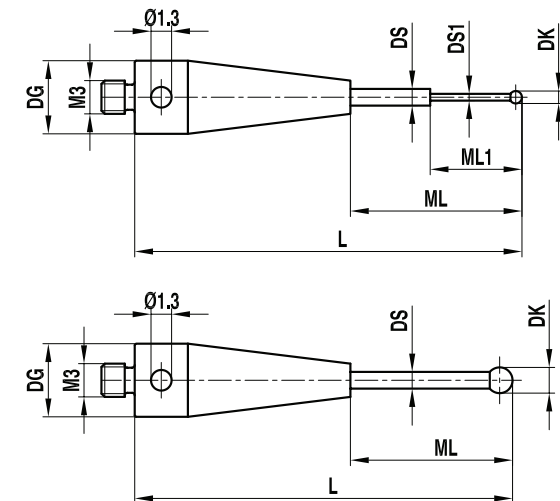

Codice Renishaw	Numero di codice ZEISS	DK (mm)	ML1/ML (mm)	DG/D (mm)	L (mm)	DS1/DS (mm)	Peso (g)
A-5004-3272	626113-0150-014	1,5	5,0	5	14	1,0	0,65
A-5004-4653	626113-0150-020	1,5	11,0	5	20	1,0	0,72
A-5555-9339	626113-0151-030	1,5	21,0	5	30	1,0	0,84
A-5555-9340	626113-0150-030	1,5	22,5	5	30	1,0	0,9
A-5004-1779	626113-0151-040	1,5	31,0	5	40	1,0	1,6
A-5004-3188	626113-0200-014	2,0	5,0	5	14	1,0	0,66
A-5004-1861	626113-0200-020	2,0	11,0	5	20	1,0	0,72
A-5004-0656	626113-0200-030	2,0	21,0	5	30	1,0	0,83
A-5555-3855	626113-0201-040	2,0	31,0	5	40	1,5	1,7
A-5555-3856	626113-0250-020	2,5	11,0	5	20	1,5	1,0
A-5555-3857	626113-0250-030	2,5	21,0	5	30	1,5	1,5
A-5004-3428	626113-0250-040	2,5	31,0	5	40	1,5	2,0

Stili di riferimento XXT (punto rosso)

Filettatura	M3
Base	Titanio
Stelo	Fibra di carbonio termostabile
Sfera	Rubino

Codice Renishaw	Numero di codice ZEISS	DK (mm)	ML1/ML (mm)	DG/D (mm)	L (mm)	DS1/DS (mm)	Peso (g)
A-5555-2033	626103-0501-030	5	21	5	30	3,5	1,1
A-5555-3858	626103-0501-050	5	41	5	50	3,5	1,4

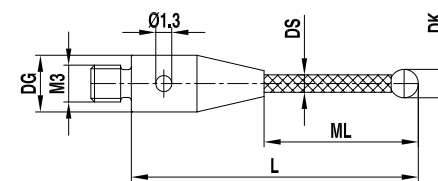

Stili in fibra di carbonio termostabile XXT

Filettatura	M3
Base	Titanio
Stelo	Fibra di carbonio termostabile
Sfera	Rubino
Note supplementari	Montaggio su perno

Codice Renishaw	Numero di codice ZEISS	DK (mm)	ML1/ML (mm)	DG/D (mm)	L (mm)	DS1/DS (mm)	Peso (g)
A-5555-3859	626103-0300-025	3	16	5	25	2,0	0,65
A-5004-0802	626103-0300-033	3	24	5	33	2,0	0,7
A-5555-1251	626103-0300-040	3	31	5	40	2,0	0,8
A-5004-1884	626103-0300-042	3	33	5	42	2,0	0,8
A-5004-0803	626103-0300-050	3	41	5	50	2,0	0,8
A-5555-3860	626103-0300-058	3	49	5	58	2,0	1,0
A-5555-3861	626103-0300-059	3	50	5	59	2,0	1,0
A-5555-3862	626103-0300-075	3	66	5	75	2,0	1,0
A-5004-2786	626103-0401-050	4	41	5	50	2,0	1,0
A-5004-2108	626103-0500-030	5	21	5	30	3,5	1,1
A-5555-3863	626103-0500-040	5	31	5	40	3,5	1,2
A-5004-0806	626103-0500-050	5	41	5	50	3,5	1,4
A-5555-3864	626103-0500-060	5	51	5	60	3,5	1,5
A-5555-1114	626103-0501-075	5	66	5	75	3,5	1,8
A-5004-3429	626103-0600-050	6	40	5	50	3,5	1,5
A-5555-3865	626103-0610-070	6	61	5	70	3,5	1,8
A-5555-1115	626103-0600-100	6	91	5	100	3,5	2,4
A-5555-3866	626103-0800-030	8	30	5	30	5,0	1,86
A-5555-3867	626103-0830-050	8	50	5	50	5,0	2,1
A-5555-3868	626103-0830-070	8	70	5	70	5,0	2,6
A-5555-3869	626103-0830-100	8	100	5	100	5,0	2,7
A-5004-0808	626103-0800-125	8	125	5	125	5,0	2,9

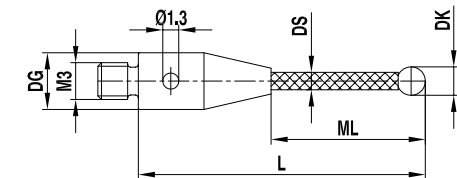

Stili in fibra di carbonio termostabile XXT con sfera in nitruro di silicio

Filettatura	M3
Base	Titanio
Stelo	Fibra di carbonio termostabile
Sfera	Nitruro di silicio
Note supplementari	Montaggio su coppa

Codice Renishaw	Numero di codice ZEISS	DK (mm)	ML1/ML (mm)	DG/D (mm)	L (mm)	DS1/DS (mm)	Peso (g)
A-5555-3870	626103-0301-033	3	24	5	33	2,0	0,7
A-5555-3871	626103-0301-050	3	41	5	50	2,0	0,8
A-5555-3872	626103-0502-050	5	41	5	50	3,5	1,4
A-5004-1858	626103-0500-075	5	66	5	75	3,5	1,8
A-5004-4635	626103-0801-070	8	70	5	70	5,0	2,6
A-5555-3874	626103-0801-125	8	125	5	125	5,0	2,9

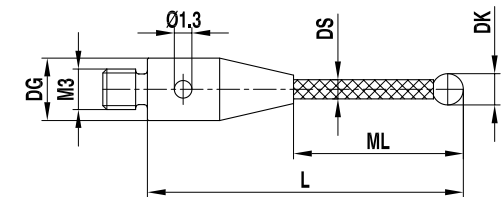

Stili di fissaggio in fibra di carbonio termostabile XXT

Filettatura	M3
Base	Titanio
Stelo	Fibra di carbonio termostabile
Sfera	Rubino
Note supplementari	Montaggio su perno

Codice Renishaw	Numero di codice ZEISS	DK (mm)	ML1/ML (mm)	DG/D (mm)	L (mm)	DS1/DS (mm)	Peso (g)
A-5555-3875	626103-0301-020	3	11	5	20	2	0,7
A-5555-3876	626103-0301-030	3	21	5	30	2	0,75
A-5004-3282	626103-0301-040	3	31	5	40	2	0,8

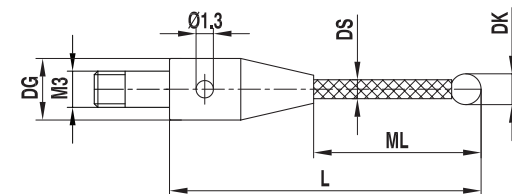

Stili di fissaggio in fibra di carbonio termostabile XXT con sfera in nitruro di silicio

Filettatura	M3
Base	Titanio
Stelo	Fibra di carbonio termostabile
Sfera	Nitruro di silicio
Note supplementari	Montaggio su coppa

Codice Renishaw	Numero di codice ZEISS	DK (mm)	ML1/ML (mm)	DG/D (mm)	L (mm)	DS1/DS (mm)	Peso (g)
A-5555-3877	626103-0311-020	3	11	5	20	2	0,7
A-5555-2445	626103-0311-030	3	21	5	30	2	0,75
A-5004-4546	626103-0311-040	3	31	5	40	2	0,8

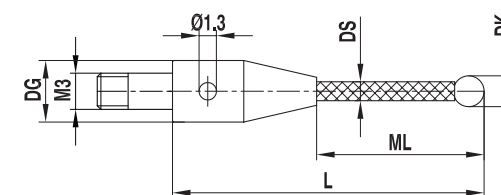

Stili in fibra di carbonio termostabile XXT per stili a stella da 1/4

Filettatura	M3
Base	Titanio
Stelo	Fibra di carbonio termostabile
Sfera	Rubino
Note supplementari	Montaggio su perno

Codice Renishaw	Numero di codice ZEISS	DK (mm)	ML1/ML (mm)	DG/D (mm)	L (mm)	DS1/DS (mm)	Peso (g)
A-5555-1273	626103-0302-020	3	11	5	20	2	0,8
A-5555-1274	626103-0302-030	3	21	5	30	2	0,9
A-5555-1275	626103-0302-040	3	31	5	40	2	1,0

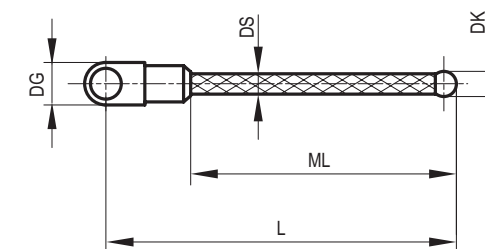

Stili in fibra di carbonio per stili a stella da 1/4 in fibra di carbonio termostabile XXT con sfera in nitruro di silicio

Filettatura	M3
Base	Titanio
Stelo	Fibra di carbonio termostabile
Sfera	Nitruro di silicio
Note supplementari	Montaggio su coppa

Codice Renishaw	Numero di codice ZEISS	DK (mm)	ML1/ML (mm)	DG/D (mm)	L (mm)	DS1/DS (mm)	Peso (g)
A-5555-3880	626103-0312-020	3	11	5	20	2	0,8
A-5555-3881	626103-0312-030	3	21	5	30	2	0,9
A-5555-3901	626103-0312-040	3	31	5	40	2	1,0

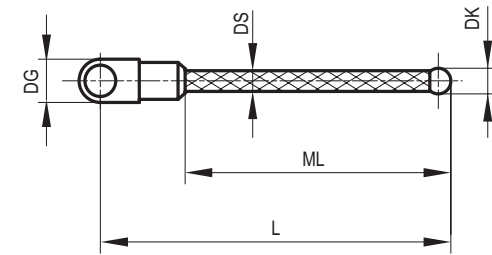

Stili in fibra di carbonio termostabile XXT per stili a stella da 1/2

Filettatura	M3
Base	Titanio
Stelo	Fibra di carbonio termostabile
Sfera	Rubino
Note supplementari	Montaggio su perno

Codice Renishaw	Numero di codice ZEISS	DK (mm)	ML1/ML (mm)	DG/D (mm)	L (mm)	DS1/DS (mm)	Peso (g)
A-5555-3882	626103-0303-020	3	11	5	20	2	1,4
A-5555-3883	626103-0303-030	3	21	5	30	2	1,5
A-5004-3284	626103-0303-040	3	31	5	40	2	1,6

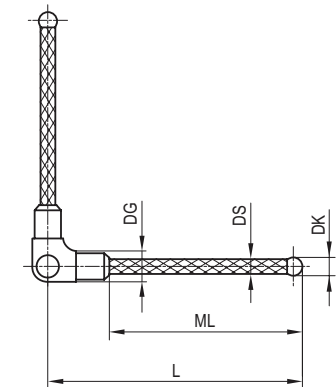

Stili in fibra di carbonio termostabile XXT a 90° per stili a stella da 1/2 con sfera in nitruro di silicio

Filettatura	M3
Base	Titanio
Stelo	Fibra di carbonio termostabile
Sfera	Nitruro di silicio
Note supplementari	Montaggio su coppa

Codice Renishaw	Numero di codice ZEISS	DK (mm)	ML1/ML (mm)	DG/D (mm)	L (mm)	DS1/DS (mm)	Peso (g)
A-5555-3884	626103-0313-020	3	11	5	20	2	1,4
A-5555-3885	626103-0313-030	3	21	5	30	2	1,5
A-5555-3886	626103-0313-040	3	31	5	40	2	1,6

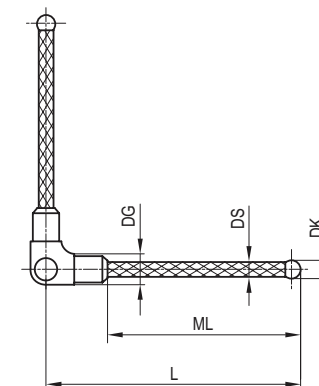

Stili in fibra di carbonio termostabile XXT a 180° per stili a stella da 1/2

Filettatura	M3
Base	Titanio
Stelo	Fibra di carbonio termostabile
Sfera	Rubino
Note supplementari	Montaggio su perno

Codice Renishaw	Numero di codice ZEISS	DK (mm)	ML1/ML (mm)	DG/D (mm)	L (mm)	DS1/DS (mm)	Peso (g)
A-5555-3887	626103-0304-020	3	11	5	20	2	1,4
A-5555-3888	626103-0304-030	3	21	5	30	2	1,5
A-5004-0654	626103-0304-040	3	31	5	40	2	1,6

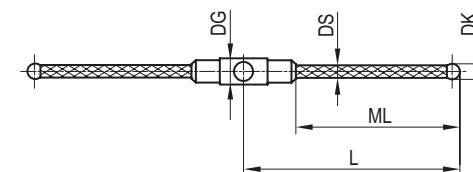

Stili in fibra di carbonio termostabile XXT a 180° per stili a stella da 1/2 con sfera in nitruro di silicio

Filettatura	M3
Base	Titanio
Stelo	Fibra di carbonio termostabile
Sfera	Nitruro di silicio
Note supplementari	Montaggio su coppa

Codice Renishaw	Numero di codice ZEISS	DK (mm)	ML1/ML (mm)	DG/D (mm)	L (mm)	DS1/DS (mm)	Peso (g)
A-5555-3889	626103-0314-020	3	11	5	20	2	1,4
A-5555-3890	626103-0314-030	3	21	5	30	2	1,5
A-5555-3891	626103-0314-040	3	31	5	40	2	1,6

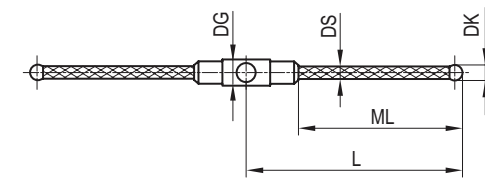

Prolunghe in fibra di carbonio XXT

Filettatura	M3
Prolunga	Fibra di carbonio termostabile

Codice Renishaw	Numero di codice ZEISS	DG/D (mm)	L (mm)	Peso (g)
A-5555-3892	626103-5020-000	5	20	1,2
A-5555-1947	626103-5025-000	5	25	1,25
A-5004-3430	626103-5030-000	5	30	1,3
A-5555-3893	626103-5040-000	5	40	1,4
A-5004-0002	626103-5050-000	5	50	1,5
A-5555-3894	626103-5060-000	5	60	1,7
A-5555-1948	626103-5075-000	5	75	1,7
A-5004-2001	626103-5080-000	5	80	1,8
A-5004-1859	626103-5100-000	5	100	2,0
A-5555-3895	626103-5130-000	5	130	2,5
A-5555-1276	626103-5150-000	5	150	2,7

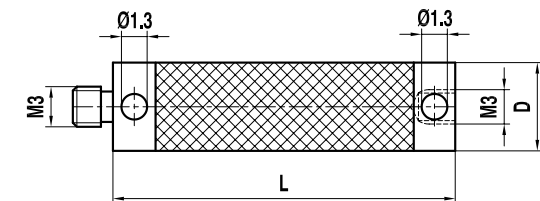

Piattello VAST XXT TL1

Filettatura	M3
Materiale	Alluminio
Note supplementari	TL1 ha due sfere in carburo adiacenti ed è adatto a teste di sonde TL1

Codice Renishaw	Numero di codice ZEISS	Numero di pezzi
A-5555-1235	620161-8055-000	1

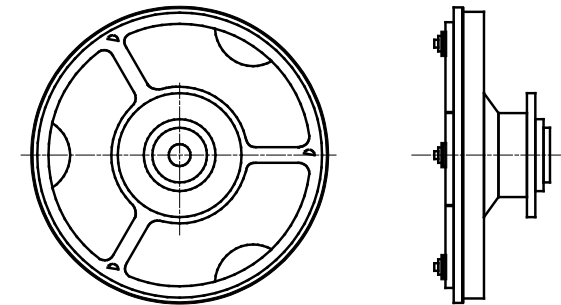

Piattello di riferimento VAST XXT TL1

Filettatura	M3
Materiale	Alluminio

Codice Renishaw	Numero di codice ZEISS	Numero di pezzi
A-5555-1236	620161-8058-000	1

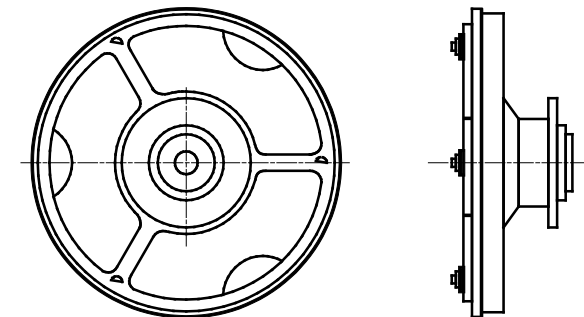

Piattello VAST XXT TL1 con adattatore a stella

Filettatura	M3
Materiale	Alluminio

Codice Renishaw	Numero di codice ZEISS	L (mm)	Numero di pezzi	Peso (g)
A-5555-1241	626103-8031-055	55	1	6,3

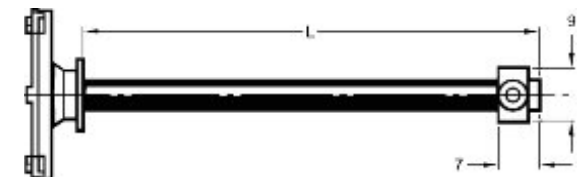

Piattello per XXT TL2

Filettatura	M3
Materiale	Alluminio

Codice Renishaw	Numero di codice ZEISS	L (mm)	Numero di pezzi	Peso (g)
A-5555-1237	620161-8065-000	75	1	5,4

Piattello di riferimento per XXT TL2

Filettatura	M3
Materiale	Alluminio

Codice Renishaw	Numero di codice ZEISS	L (mm)	Numero di pezzi	Peso (g)
A-5555-1238	620161-8068-000	75	1	5,4



Piattello VAST XXT TL3

Filettatura	M3
Materiale	Alluminio
Note supplementari	TL3 ha due sfere in carburo separate ed è adatto a teste di sonde TL3

Codice Renishaw	Numero di codice ZEISS	Numero di pezzi
A-5555-1239	620161-8075-000	1

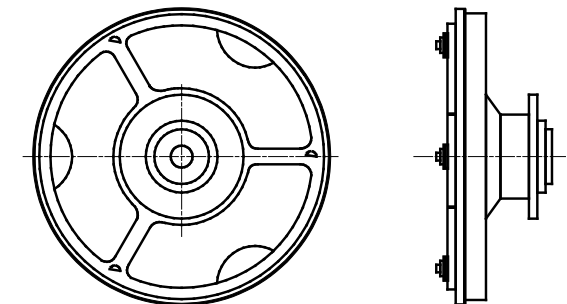

Piattello di riferimento VAST XXT TL3

Filettatura	M3
Materiale	Alluminio

Codice Renishaw	Numero di codice ZEISS	Numero di pezzi
A-5555-1240	620161-8078-000	1

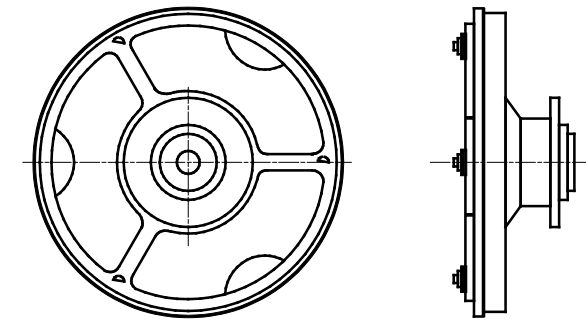

Piattello VAST XXT TL3 stella

Filettatura	M3
Materiale	Alluminio

Codice Renishaw	Numero di codice ZEISS	L (mm)	Numero di pezzi	Peso (g)
A-5555-1242	626103-8033-055	55	1	6,3

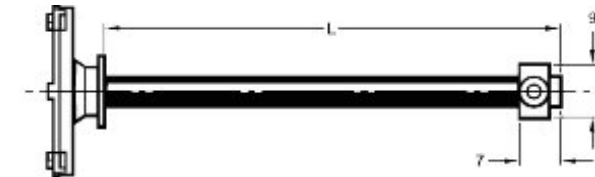

Vite di fissaggio XXT

Filettatura	M3
Materiale	Titanio

Codice Renishaw	Numero di codice ZEISS	DG/D (mm)	L (mm)	Peso (g)
A-5004-1856	626103-6110-004	5	8	0,5

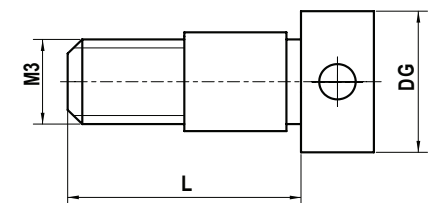

Vite di fissaggio XXT con filettatura interna M3

Filettatura	M3
Materiale	Titanio

Codice Renishaw	Numero di codice ZEISS	DG/D (mm)	L (mm)	Peso (g)
A-5004-1857	626103-6110-005	5	8	0,7

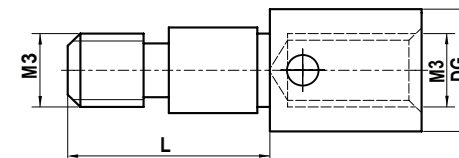

Centro stella XXT 90°, 1 via

Filettatura	M3
Materiale	Titanio

Codice Renishaw	Numero di codice ZEISS	L (mm)	EAL/B (mm)	Peso (g)
A-5004-3437	626103-6110-001	6,5	5	0,64

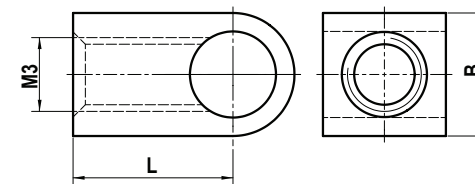

Centro stella XXT 180°, 2 vie

Filettatura	M3
Materiale	Titanio

Codice Renishaw	Numero di codice ZEISS	L (mm)	EAL/B (mm)	Peso (g)
A-5555-3896	626103-6110-002	13	5	1,05

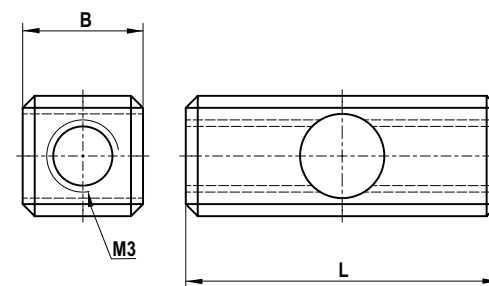

Centro stella XXT stella

Filettatura	M3
Materiale	Titanio

Codice Renishaw	Numero di codice ZEISS	L (mm)	EAL/B (mm)	Peso (g)
A-5004-3185	626103-6110-003	13	5	1,8

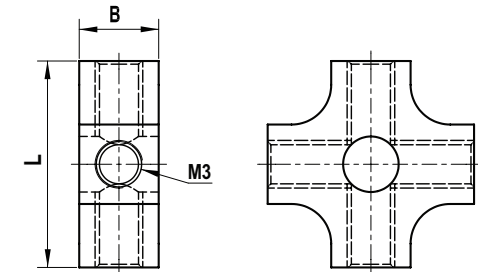

Centro stella XXT, stella a 6

Filettatura	M3
Materiale	Titanio

Codice Renishaw	Numero di codice ZEISS	DG/D (mm)	EAL/B (mm)	Peso (g)
A-5555-3898	626103-6110-006	12	5	1,79

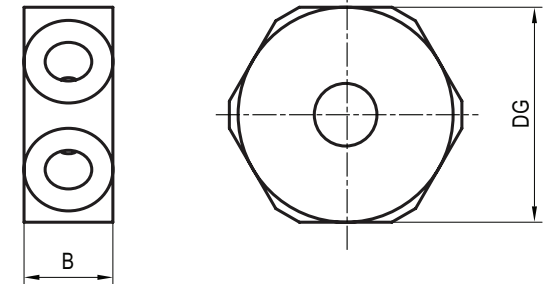

Centro stella XXT, stella a 8

Filettatura	M3
Materiale	Titanio

Codice Renishaw	Numero di codice ZEISS	DG/D (mm)	EAL/B (mm)	Peso (g)
A-5555-3899	626103-6110-007	14	5	2,31

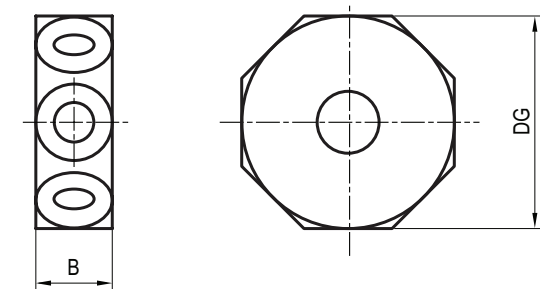

Snodo XXT

Filettatura	M3
Materiale	Titanio

Codice Renishaw	Numero di codice ZEISS	L (mm)	EAL/B (mm)	Peso (g)
A-5004-3285	626103-6180-001	10	5	1,65

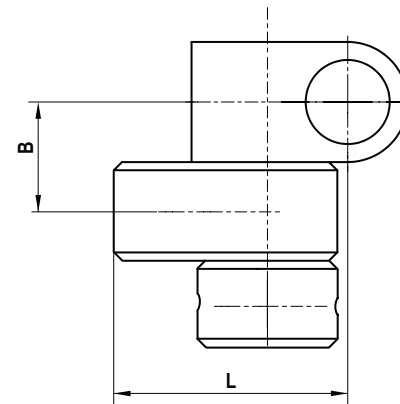

Stili in carburo

Filettatura	M3
Base	Acciaio inox
Stelo	Carburo di tungsteno
Sfera	Rubino
Note supplementari	Montaggio su perno

Codice Renishaw	Numero di codice ZEISS	DK (mm)	ML1/ML (mm)	DG/D (mm)	L (mm)	DS1/DS (mm)	Peso (g)
A-5555-2446	–	0,2	2,3/9,0	4,0	22,0	0,18/1,0	1,0
A-5555-2447	–	0,25	2,3/9,0	4,0	22,0	0,18/1,0	1,0
A-5555-0273	602030-8121-000	0,3	2,3/9,0	4,0	22,0	0,2/1,0	1,0
A-5555-0267	602030-8115-000	0,5	2,5/11,25	4,0	21,25	0,3/1,0	1,0
A-5555-0268	602030-8116-000	0,6	4,6/9,0	4,0	22,0	0,4/1,0	1,0
A-5555-0269	602030-8117-000	0,8	4,8/9,0	4,0	22,0	0,6/1,0	1,0
A-5555-0272	602030-8120-000	1,0	5,0/5,5	4,0	10,5	0,8/1,0	1,0
A-5555-0270	602030-8118-000	1,0	5,0/9,0	4,0	22,0	0,8/1,0	1,0
A-5555-0271	602030-8119-000	1,5	9,0	4,0	22,0	1,0	1,0
A-5555-0274	602030-8023-000	2,0	15,0	4,0	21,0	1,0	1,0
A-5555-0261	602030-8104-000	2,0	14,0	4,0	22,0	1,0	1,0
A-5555-2448	–	2,0	34,0	4,0	40,0	1,5	1,0
A-5555-0277	602030-8106-000	3,0	13,0	4,0	21,0	2,0	1,0
A-5555-0276	602030-8021-000	3,0	15,5	4,0	21,5	1,5	1,0
A-5555-0262	602030-8113-000	3,0	21,5	5,5	40,0	2,0	4,0
A-5004-4513	–	3,0	31,5	5,5	50,0	2,0	4,5

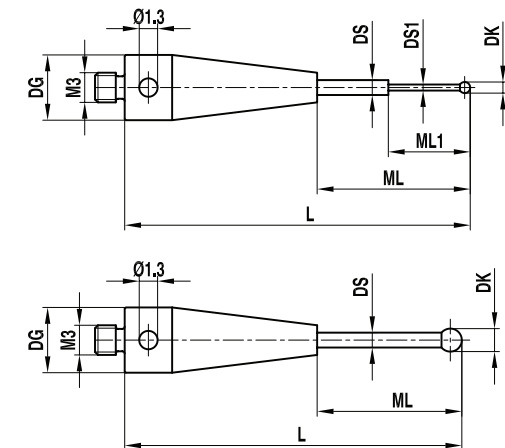

Codice Renishaw	Numero di codice ZEISS	DK (mm)	ML1/ML (mm)	DG/D (mm)	L (mm)	DS1/DS (mm)	Peso (g)
A-5555-2449	–	4,0	22,0	4,0	30,0	2,0	2,0
A-5004-2785	–	4,0	32,0	4,0	40,0	2,0	2,0
A-5004-1008	–	4,0	42,0	4,0	50,0	2,0	2,9
A-5555-2450	–	5,0	22,0	4,0	30,0	2,0	2,1
A-5555-2451	–	5,0	32,0	4,0	40,0	2,0	2,0
A-5555-2452	–	5,0	42,0	4,0	50,0	2,0	3,0
A-5555-2453	–	5,0	52,0	4,0	60,0	2,0	3,5
A-5555-2454	–	6,0	22,0	4,0	30,0	2,0	2,3
A-5004-6728	–	6,0	32,0	4,0	40,0	2,0	2,7
A-5555-1118	–	6,0	42,0	4,0	50,0	2,0	3,2

Stili in ceramica

Filettatura	M3
Base	Acciaio inox
Stelo	Ceramica
Sfera	Rubino
Note supplementari	Montaggio su perno

Codice Renishaw	Numero di codice ZEISS	DK (mm)	ML1/ML (mm)	DG/D (mm)	L (mm)	DS1/DS (mm)	Peso (g)
A-5555-0264	602030-8102-000	4	26,0	4	32,0	2	1,0
A-5555-0266	602030-8101-000	5	24,5	4	32,5	2	1,0
A-5555-0275	602030-8020-000	6	9,0	4	13,0	2	1,0
A-5004-4757	–	6	30,5	4	43,5	2	1,2
A-5004-2741	–	6	50,5	4	63,5	2	1,5
A-5555-2455	–	8	18,5	4	31,5	2	1,3

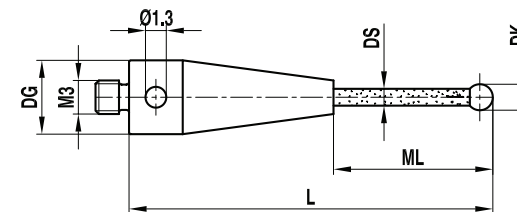

Stili cilindrici

Filettatura	M3
Base	Acciaio inox
Stelo	Carburo di tungsteno
Cilindro	Carburo

Codice Renishaw	Numero di codice ZEISS	DK (mm)	ML1/ML (mm)	DG/D (mm)	L (mm)	DS1/DS (mm)	Peso (g)
A-5004-0254	602030-8097-000	1,5	1,5	4	11	1,0	0,4
A-5004-0255	602030-8099-000	3,0	4,0	4	13	1,5	0,7

Filettatura	M3
Base	Acciaio inox
Stelo	Carburo di tungsteno
Cilindro	Rubino

Codice Renishaw	Numero di codice ZEISS	DK (mm)	ML1/ML (mm)	DG/D (mm)	L (mm)	DS1/DS (mm)	Peso (g)
A-5004-0256	602030-8107-000	2	7	4	21	1	0,7

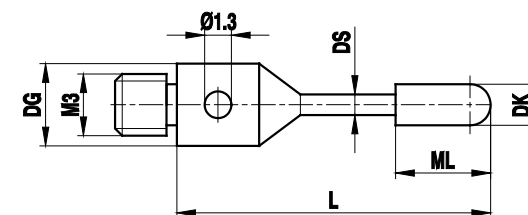
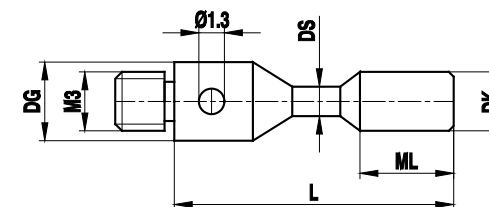

Prolunghe

Filettatura	M3
Materiale	Acciaio inox

Codice Renishaw	Numero di codice ZEISS	DG/D (mm)	L (mm)	Peso (g)
A-5004-7609	602030-8301-000	4	10	0,7
A-5004-7583	602030-8302-000	4	20	1,6
A-5555-0286	602030-8303-000	4	30	2,6
A-5555-0287	602030-8304-000	4	40	3,7
A-5555-0288	602030-8305-000	4	50	4,7

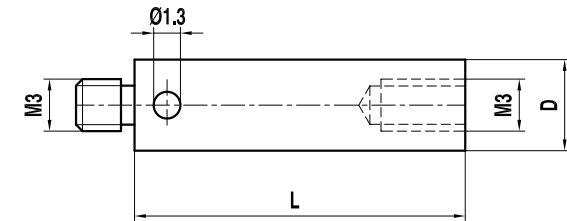

Portastilo a 5 vie, rotante

Filettatura	M3
Materiale	Acciaio inox

Codice Renishaw	Numero di codice ZEISS	L (mm)	EAL/B (mm)	Peso (g)
A-5555-0303	602030-8382-000	11,5	12	4,2

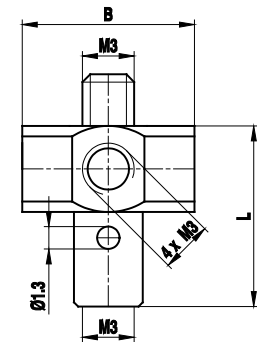

Supporto per stili a 90°

Filettatura	M3
Materiale	Acciaio inox

Codice Renishaw	Numero di codice ZEISS	DG/D (mm)	L (mm)	DS1/DS (mm)	Peso (g)
A-5004-4561	-	4	30	1,0	2,9
A-5555-2456	-	4	30	1,5	2,9

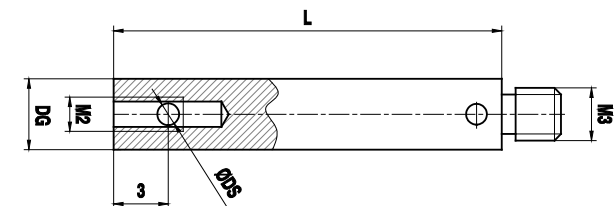

Snodo rotante

Filettatura	M3
Materiale	Acciaio inox

Codice Renishaw	Numero di codice ZEISS	L (mm)	EAL/B (mm)	Peso (g)
A-5000-7616	602030-9102-000	12	6	3,6

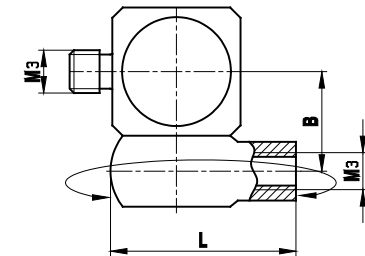

Adattatore

Filettatura	M3/M2
Materiale	Acciaio inox

Codice Renishaw	Numero di codice ZEISS	DG/D (mm)	L (mm)	Filettatura da/a	Peso (g)
A-5004-7592	602030-8341-000	4	5	M3/M2	0,5
A-5555-0306	602030-8345-000	4	5	M2/M3	0,5
A-5555-2457	000000-1049-178	4	7	M2/M3	0,5

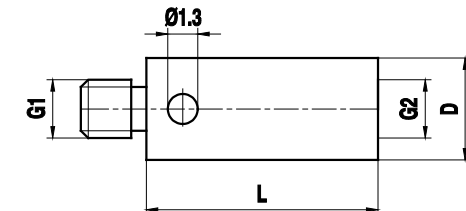

Strumenti e accessori Renishaw per il montaggio di stili M2, M3 o M5 su teste di misura ZEISS

Utensile per stilo

Filettatura	M2 e M3
Materiale	Acciaio inox

Codice Renishaw	Numero di codice ZEISS	DG/D (mm)	L (mm)	Peso (g)
A-5555-0233	602030-0001-000	1,2	23	1

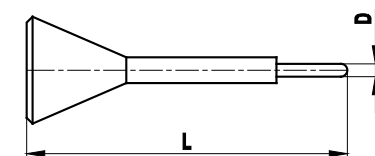

Utensile per montaggio stilo

Filettatura	M3
Materiale	Acciaio inox

Codice Renishaw	Numero di codice ZEISS
A-5555-0307	000000-1018-201



Chiavi a brugola

Materiale	Acciaio
-----------	---------

Codice Renishaw	Numero di codice ZEISS	EAL/B (mm)
A-5555-0235	602030-0042-000	0,9
A-5555-0234	602030-0002-000	1,5
A-5555-0328	000000-0015-245	2,0
A-5555-0236	602030-0021-000	2,5
A-5555-2458	000000-0015-247	3,0
A-5555-2459	000000-0015-248	4,0
A-5555-2460	–	5,0
A-5555-2461	–	10,0



Stili M2 Renishaw, adattatori e accessori per sonde analogiche ZEISS

Stili in carburo

Filettatura	M2
Base	Acciaio inox
Stelo	Carburo di tungsteno
Sfera	Rubino
Note supplementari	Montaggio su perno a eccezione di sfere con diametro compreso fra 0,2 e 0,6 mm

Codice Renishaw	Numero di codice ZEISS	DK (mm)	ML1/ML (mm)	DG/D (mm)	L (mm)	DS1/DS (mm)	Peso (g)
A-5004-5753	–	0,2	2,3/12,5	3	17,0	0,18/1,0	0,4
A-5555-2462	–	0,25	2,3/12,5	3	17,0	0,18/1,0	0,4
A-5555-9159	–	0,3	2,3/13,5	3	18,0	0,2/1,0	0,4
A-5555-1101	–	0,5	2,5/13,5	3	18,0	0,3/1,0	0,4
A-5555-9161	–	0,6	4,6/13,8	3	18,3	0,4/1,0	0,4
A-5555-9162	–	0,8	4,8/13,5	3	18,0	0,6/1,0	0,4
A-5555-0308	602030-8006-000	1,0	6,5	3	10,5	0,8	0,3
A-5555-0309	–	1,0	11,5	3	15,5	0,8	0,3
A-5555-2463	–	1,0	5,0/14,0	3	18,5	0,8/1,0	0,4
A-5555-0282	602030-8001-000	2,0	5,0	3	11,0	1,0	1,0
A-5555-0310	602030-8008-000	2,0	7,0	3	11,0	1,0	1,0
A-5555-0311	602030-8009-000	2,0	12,0	3	16,0	1,0	1,0
A-5003-3822	602030-8005-000	2,0	15,0	3	21,0	1,0	1,0
A-5555-2465	–	2,5	6,0	3	12,0	1,5	1,0
A-5555-2466	–	3,0	6,0	3	12,0	2,0	1,0
A-5003-0938	602030-8003-000	3,0	15,5	3	21,5	1,5	1,0
A-5555-0312	602030-8015-000	4,0	6,0	3	12,0	2,0	1,0
A-5555-0313	602030-8016-000	4,0	16,0	3	22,0	2,0	1,0
A-5555-0283	602030-8034-000	5,0	16,5	3	22,5	2,0	1,0

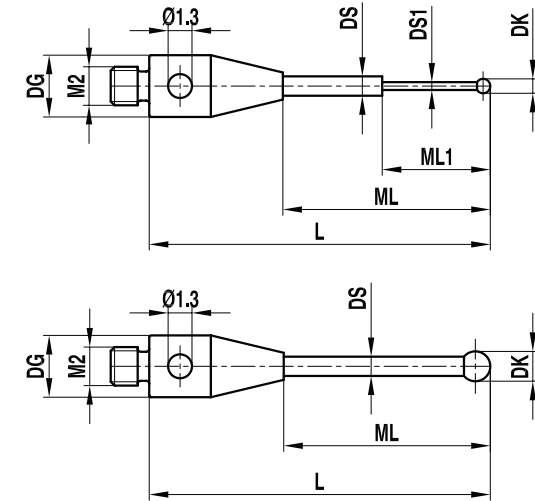

Stili in ceramica

Filettatura	M2
Base	Acciaio inox
Stelo	Ceramica
Sfera	Rubino
Note supplementari	Montaggio su perno

Codice Renishaw	Numero di codice ZEISS	DK (mm)	ML1/ML (mm)	DG/D (mm)	L (mm)	DS1/DS (mm)	Peso (g)
A-5555-2467	–	4	12,0	3	16,0	2	0,8
A-5555-2468	–	4	30,0	3	36,0	2	1,0
A-5555-2469	–	5	10,0	3	14,0	2	0,8
A-5555-0279	–	5	16,5	3	22,5	2	1,0
A-5555-2470	–	5	32,0	3	38,0	2	1,0
A-5555-0278	602030-8002-000	6	9,0	3	13,0	2	1,0

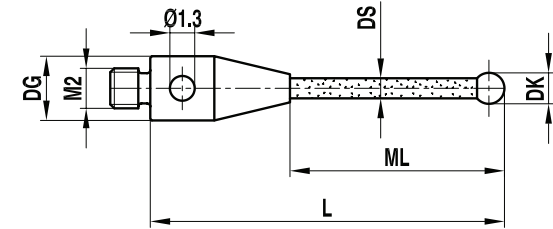

Stili in acciaio inox

Filettatura	M2
Base	Acciaio inox
Stelo	Acciaio inox
Sfera	Rubino
Note supplementari	Montaggio su perno

Codice Renishaw	Numero di codice ZEISS	DK (mm)	ML1/ML (mm)	DG/D (mm)	L (mm)	DS1/DS (mm)	Peso (g)
A-5555-2471	-	4	32,0	3	32,0	3	1,7
A-5555-2472	-	4	42,0	3	42,0	3	2,4
A-5555-2473	-	4	52,0	3	52,0	3	2,9
A-5555-2474	-	5	22,0	3	22,0	3	1,3
A-5555-2475	-	5	32,0	3	32,0	3	1,9
A-5555-2476	-	5	42,5	3	42,5	3	2,5
A-5555-2477	-	5	52,5	3	52,5	3	3,1
A-5555-0314	-	6	13,0	3	13,0	3	0,9
A-5555-0315	-	6	28,0	3	28,0	3	1,8
A-5555-0316	-	8	13,0	3	1,03	3	2,0

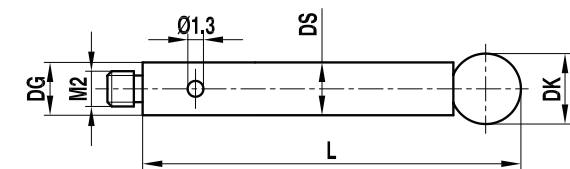

Stili a stella

Filettatura	M2
Base	Acciaio inox
Stelo	Acciaio inox
Sfera	Rubino
Note supplementari	Montaggio su perno

Codice Renishaw	Numero di codice ZEISS	DK (mm)	ML1/ML (mm)	L (mm)	DS1/DS (mm)	EAL/B (mm)	Peso (g)
A-5555-0295	602030-8010-000	2	4,5	22	1,4	5,5	1
A-5555-0294	602030-8011-000	2	9,5	32	1,4	5,5	1

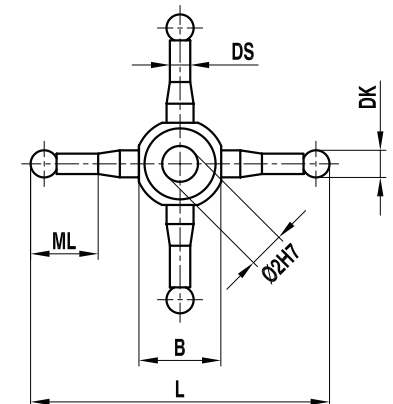

Stili per configurazioni a stella

Filettatura	M2
Base	Acciaio inox
Stelo	Acciaio inox
Sfera	Rubino
Note supplementari	Montaggio su perno

Codice Renishaw	Numero di codice ZEISS	DK (mm)	ML1/ML (mm)	DG/D (mm)	L (mm)	DS1/DS (mm)	Peso (g)
A-5555-0296	602030-8012-000	2	13,5	3	19,5	1,5	1

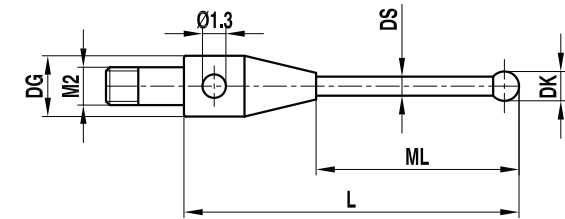

Stili a disco sferico

Filettatura	M2
Base	Acciaio inox
Stelo	Carburo di tungsteno
Disco	Ceramica

Codice Renishaw	Numero di codice ZEISS	DK (mm)	ML1/ML (mm)	DG/D (mm)	L (mm)	DS1/DS (mm)	EAL/B (mm)	Peso (g)
A-5555-0298	602030-8202-000	4	19	3	32	1,0	1,0	1
A-5555-0297	602030-8201-000	8	19	3	32	1,5	1,5	1

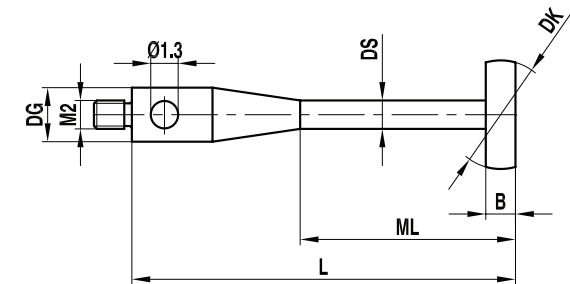

Stili a disco sferico

Filettatura	M2
Base	Acciaio inox
Stelo	Acciaio inox
Disco	Ceramica

Codice Renishaw	Numero di codice ZEISS	DK (mm)	L (mm)	EAL/B (mm)	Peso (g)
A-5555-0299	602030-8203-000	14	5,5	2,0	1
A-5555-0300	602030-8204-000	20	5,5	2,5	3

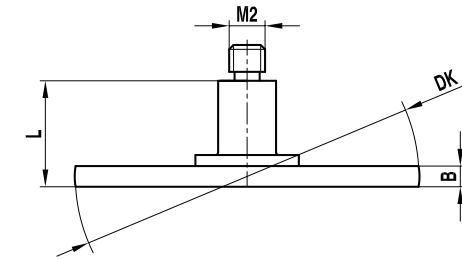

Stili cilindrici

Filettatura	M2
Base	Acciaio inox
Stelo	Carburo di tungsteno
Cilindro	Carburo di tungsteno

Codice Renishaw	Numero di codice ZEISS	DK (mm)	ML1/ML (mm)	DG/D (mm)	L (mm)	DS1/DS (mm)	Peso (g)
A-5004-0936	602030-8096-000	1,5	1,5	3	11	1,0	0,3
A-5004-0937	602030-8098-000	3,0	4,0	3	13	1,5	0,6

Filettatura	M2
Base	Acciaio inox
Stelo	Carburo di tungsteno
Cilindro	Rubino

Codice Renishaw	Numero di codice ZEISS	DK (mm)	ML1/ML (mm)	DG/D (mm)	L (mm)	DS1/DS (mm)	Peso (g)
A-5004-0182	602030-8100-000	2	7	3	21	1	0,6

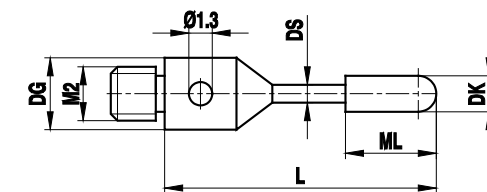
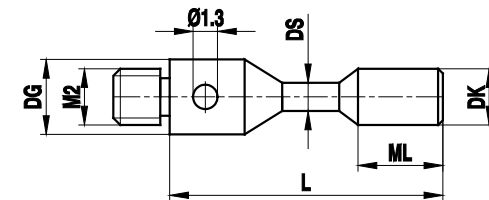

Prolunga

Filettatura	M2
Materiale	Acciaio inox

Codice Renishaw	Numero di codice ZEISS	DG/D (mm)	L (mm)	Peso (g)
A-5004-7610	602030-8321-000	3	5	0,2
A-5004-7585	602030-8322-000	3	10	0,5
A-5004-7586	602030-8323-000	3	20	1,0
A-5004-7591	602030-8324-000	3	30	1,4
A-5555-1308	–	3	35	1,8
A-5004-7611	602030-8325-000	3	40	2,2
A-5555-2481	–	3	50	2,7

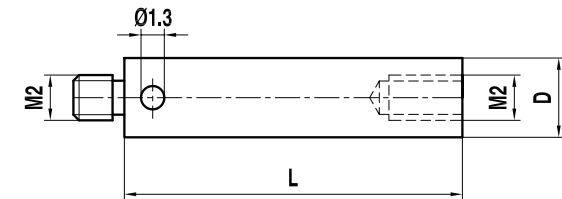

Portastilo a 5 vie, rotante

Filettatura	M2
Materiale	Acciaio inox

Codice Renishaw	Numero di codice ZEISS	L (mm)	EAL/B (mm)	Peso (g)
A-5000-3627	602030-8381-000	7,5	7	1,2

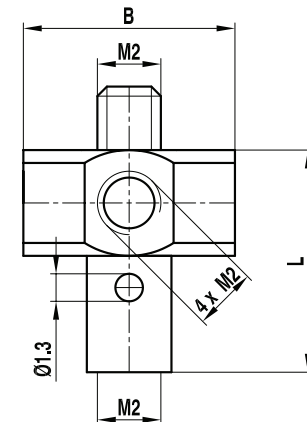

Portastilo a 5 vie, piccolo/grande

Filettatura	M2
Materiale	Acciaio inox

Codice Renishaw	Numero di codice ZEISS	L (mm)	EAL/B (mm)	Peso (g)
A-5555-0320	602030-9103-000	5,4	7,0	1,0
A-5555-0319	602030-9104-000	9,1	10,5	3,4

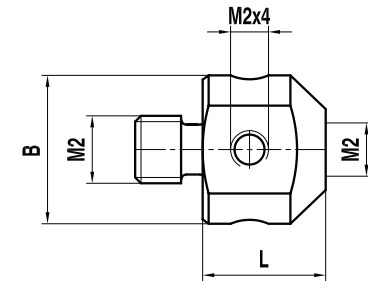

Supporto per stili a 90°

Filettatura	M2
Materiale	Acciaio inox

Codice Renishaw	Numero di codice ZEISS	DG/D (mm)	L (mm)	DS1/DS (mm)	Peso (g)
A-5555-2478	-	3	30	1,0	2,9
A-5555-2479	-	3	30	1,5	2,9

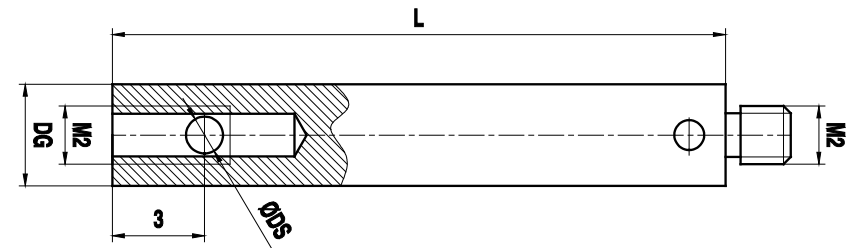

Snodo rotante

Filettatura	M2
Materiale	Acciaio inox

Codice Renishaw	Numero di codice ZEISS	L (mm)	EAL/B (mm)	Peso (g)
A-5000-7534	602030-9101-000	8	4,5	2

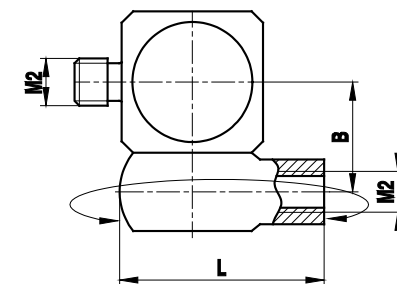

Snodo rotante, angolo di rotazione 360°, angolo di oscillazione 180°

Filettatura	M2
Materiale	Acciaio inox

Codice Renishaw	Numero di codice ZEISS	DG/D (mm)	L (mm)	Peso (g)
A-5000-9902	602030-9105-000	4	16,5	1,5

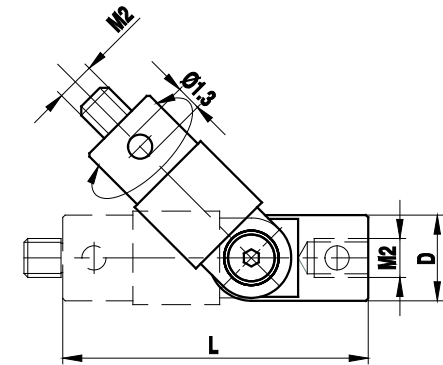

Indice

Codice Renishaw	Codice ZEISS	DK (mm)	ML1/ML (mm)	DG/D (mm)	L (mm)	DS1/DS (mm)	EAL/B (mm)	Peso (g)	A (mm)	Filettatura/ foro (mm)	Filettatura (da/a)	MB (mm)	G1 (mm)	SW (mm)	Pagina n.
A-1034-0124	–	30	–	24	145	–	–	–	–	–	–	–	–	22	36
A-5000-3627	602030-8381-000	–	–	–	7.5	–	7	1.2	–	–	–	–	–	–	66
A-5000-7534	602030-9101-000	–	–	–	8	–	4.5	2	–	–	–	–	–	–	67
A-5000-7616	602030-9102-000	–	–	–	12	–	6	3.6	–	–	–	–	–	–	59
A-5000-9902	602030-9105-000	–	–	4	16.5	–	–	1.5	–	–	–	–	–	–	68
A-5003-0145	–	1.5	8.0/20.0	11	30	1.0/1.5	–	6	–	–	–	–	–	–	7
A-5003-0850	–	–	–	11	20	–	–	5.7	–	–	–	–	–	–	33
A-5003-0938	602030-8003-000	3	15.5	3	21.5	1.5	–	1	–	–	–	–	–	–	61
A-5003-3822	602030-8005-000	2	15	3	21	1	–	1	–	–	–	–	–	–	61
A-5003-7499	–	3.5	65	11	75	2.5	–	6.5	–	–	–	–	–	–	7
A-5004-0002	626103-5050-000	–	–	5	50	–	–	1.5	–	–	–	–	–	–	48
A-5004-0182	602030-8100-000	2	7	3	21	1	–	0.6	–	–	–	–	–	–	65
A-5004-0254	602030-8097-000	1.5	1.5	4	11	1	–	0.4	–	–	–	–	–	–	57
A-5004-0255	602030-8099-000	3	4	4	13	1.5	–	0.7	–	–	–	–	–	–	57
A-5004-0256	602030-8107-000	2	7	4	21	1	–	0.7	–	–	–	–	–	–	57
A-5004-0654	626103-0304-040	3	31	5	40	2	–	1.6	–	–	–	–	–	–	47
A-5004-0656	626113-0200-030	2	21	5	30	1	–	0.83	–	–	–	–	–	–	42
A-5004-0802	626103-0300-033	3	24	5	33	2	–	0.7	–	–	–	–	–	–	43
A-5004-0803	626103-0300-050	3	41	5	50	2	–	1	–	–	–	–	–	–	43
A-5004-0806	626103-0500-050	5	41	5	50	3.5	–	1.4	–	–	–	–	–	–	43
A-5004-0808	626103-0800-125	8	125	5	125	5	–	2.9	–	–	–	–	–	–	43
A-5004-0936	602030-8096-000	1.5	1.5	3	11	1	–	0.3	–	–	–	–	–	–	65
A-5004-0937	602030-8098-000	3	4	3	13	1.5	–	0.6	–	–	–	–	–	–	65
A-5004-1008	–	4	42	4	50	2	–	2.9	–	–	–	–	–	–	56
A-5004-1702	626113-0050-013	0.5	2.3/4.0	5	13	0.3/1.0	–	0.61	–	–	–	–	–	–	41
A-5004-1779	626113-0151-040	1.5	31	5	40	1	–	1.6	–	–	–	–	–	–	42
A-5004-1856	626103-6110-004	–	–	5	8	–	–	0.5	–	–	–	–	–	–	51
A-5004-1857	626103-6110-005	–	–	5	8	–	–	0.7	–	–	–	–	–	–	52
A-5004-1858	626103-0500-075	5	68	5	75	3.5	–	1.8	–	–	–	–	–	–	44
A-5004-1859	626103-5100-000	–	–	5	100	–	–	2	–	–	–	–	–	–	48
A-5004-1861	626113-0200-020	2	11	5	20	1	–	0.72	–	–	–	–	–	–	42
A-5004-1863	626113-0100-020	1	5.0/11	5	20	0.8/1.0	–	0.69	–	–	–	–	–	–	41
A-5004-1883	626113-0080-034	0.8	4.1/25	5	34	0.6/1.0	–	0.8	–	–	–	–	–	–	41
A-5004-1884	626103-0300-042	3	33	5	42	2	–	0.8	–	–	–	–	–	–	43

Codice Renishaw	Codice ZEISS	DK (mm)	ML1/ML (mm)	DG/D (mm)	L (mm)	DS1/DS (mm)	EAL/B (mm)	Peso (g)	A (mm)	Filettatura/ foro (mm)	Filettatura (da/a)	MB (mm)	G1 (mm)	SW (mm)	Pagina n.
A-5004-2001	626103-5080-000	–	–	5	80	–	–	1.8	–	–	–	–	–	–	48
A-5004-2108	626103-0500-030	5	21	5	30	3.5	–	1.1	–	–	–	–	–	–	43
A-5004-2109	626115-6110-003	–	–	–	–	–	20	31.5	–	–	–	–	–	–	27
A-5004-2185	626113-0030-020	0.3	2.3/11	5	20	0.2/1.0	–	0.69	–	–	–	–	–	–	41
A-5004-2186	626113-0050-013	0.5	2.3/11	5	20	0.3/1.0	–	0.69	–	–	–	–	–	–	41
A-5004-2741	–	6	50.5	4	63.5	2	–	1.5	–	–	–	–	–	–	56
A-5004-2785	–	4	32	4	40	2	–	2	–	–	–	–	–	–	56
A-5004-2786	626103-0401-050	4	41	5	50	2	–	1	–	–	–	–	–	–	43
A-5004-3176	626113-0030-013	0.3	2.3/4.0	5	13	0.2/1.0	–	0.62	–	–	–	–	–	–	41
A-5004-3179	626113-0060-020	0.6	4.6/11	5	20	0.4/1.0	–	0.68	–	–	–	–	–	–	41
A-5004-3185	626103-6110-003	–	–	–	13	–	5	1.8	–	–	–	–	–	–	53
A-5004-3187	626113-0100-014	1	5	5	14	0.8	–	0.63	–	–	–	–	–	–	41
A-5004-3188	626113-0200-014	2	5	5	14	1	–	0.66	–	–	–	–	–	–	42
A-5004-3272	626113-0150-014	1.5	5	5	14	1	–	0.65	–	–	–	–	–	–	42
A-5004-3273	626113-0080-014	0.8	5	5	14	0.6	–	0.62	–	–	–	–	–	–	41
A-5004-3274	626113-0080-020	0.8	4.8/11	5	14	0.6/1.0	–	0.69	–	–	–	–	–	–	41
A-5004-3282	626103-0301-040	3	31	5	40	2	–	0.8	–	–	–	–	–	–	44
A-5004-3284	626103-0303-040	3	31	5	40	2	–	1.6	–	–	–	–	–	–	46
A-5004-3285	626103-6180-001	–	–	–	10	–	5	1.65	–	–	–	–	–	–	54
A-5004-3427	626113-0100-030	1	5.0/21	5	30	0.8/1.0	–	0.8	–	–	–	–	–	–	41
A-5004-3428	626113-0250-040	2.5	31	5	40	1.5	–	2	–	–	–	–	–	–	42
A-5004-3429	626103-0600-050	6	40	5	50	3.5	–	1.5	–	–	–	–	–	–	43
A-5004-3430	626103-5030-000	–	–	5	30	–	–	1.3	–	–	–	–	–	–	48
A-5004-3437	626103-6110-001	–	–	–	6.5	–	5	0.64	–	–	–	–	–	–	52
A-5004-3519	626113-0103-020	1	11	5	20	0.8	–	0.7	–	–	–	–	–	–	41
A-5004-4166	–	1	5.0/20.0	11	30	0.8/1.0	–	6	–	–	–	–	–	–	7
A-5004-4513	–	3	31.5	5.5	50	2	–	4.5	–	–	–	–	–	–	55
A-5004-4546	626103-0311-040	3	31	5	40	2	–	0.8	–	–	–	–	–	–	45
A-5004-4561	–	–	–	4	30	1	–	2.9	–	–	–	–	–	–	58
A-5004-4635	626103-0801-070	8	70	5	70	5	–	2.6	–	–	–	–	–	–	44
A-5004-4653	626113-0150-020	1.5	11	5	20	1	–	0.72	–	–	–	–	–	–	42
A-5004-4757	–	6	30.5	4	43.5	2	–	1.2	–	–	–	–	–	–	56
A-5004-5753	–	0.2	2.3/12.5	3	17	0.18/1.0	–	0.4	–	–	–	–	–	–	61
A-5004-6728	–	6	32	4	40	2	–	2.7	–	–	–	–	–	–	56
A-5004-7583	602030-8302-000	–	–	4	20	–	–	1.6	–	–	–	–	–	–	58

Codice Renishaw	Codice ZEISS	DK (mm)	ML1/ML (mm)	DG/D (mm)	L (mm)	DS1/DS (mm)	EAL/B (mm)	Peso (g)	A (mm)	Filettatura/ foro (mm)	Filettatura (da/a)	MB (mm)	G1 (mm)	SW (mm)	Pagina n.
A-5004-7585	602030-8322-000	–	–	3	10	–	–	0.5	–	–	–	–	–	–	66
A-5004-7586	602030-8323-000	–	–	3	20	–	–	1	–	–	–	–	–	–	66
A-5004-7591	602030-8324-000	–	–	3	30	–	–	1.4	–	–	–	–	–	–	66
A-5004-7592	602030-8341-000	–	–	4	5	–	–	0.5	–	–	M3/M2	–	–	–	59
A-5004-7609	602030-8301-000	–	–	4	10	–	–	0.7	–	–	–	–	–	–	58
A-5004-7610	602030-8321-000	–	–	3	5	–	–	0.2	–	–	–	–	–	–	66
A-5004-7611	602030-8325-000	–	–	3	40	–	–	2.2	–	–	–	–	–	–	66
A-5555-0013	600331-0001-000	–	–	18	10	–	–	12	–	–	–	–	–	–	35
A-5555-0014	602030-0018-000	–	–	18	12	–	–	10	–	–	–	–	–	–	35
A-5555-0018	602030-9010-000	3	15	11	25	2	–	4	–	–	–	–	–	–	7
A-5555-0019	600342-8020-000	3	23.5	11	33.5	2	–	4.5	–	–	–	–	–	–	7
A-5555-0020	602030-9011-000	3	40	11	50	2	–	5.2	–	–	–	–	–	–	7
A-5555-0021	600342-8021-000	3	48	11	58	2	–	5.5	–	–	–	–	–	–	7
A-5555-0022	600342-8025-000	4	23.5	11	33.5	2	–	4.5	–	–	–	–	–	–	7
A-5555-0024	602030-9013-000	5	40	11	50	3.5	–	9	–	–	–	–	–	–	8
A-5555-0025	600342-8022-000	5	43	11	53	3.5	–	9.8	–	–	–	–	–	–	8
A-5555-0026	602030-9015-000	5	65	11	75	3.5	–	12.5	–	–	–	–	–	–	8
A-5555-0027	600342-8026-000	6	44	11	54	3.5	–	10	–	–	–	–	–	–	8
A-5555-0028	600342-8027-000	7	45	11	55	3.5	–	10	–	–	–	–	–	–	8
A-5555-0029	600342-8023-000	8	50.5	11	63.5	6	–	24.8	–	–	–	–	–	–	8
A-5555-0030	–	8	41.5	19	63.5	6	–	36.7	–	–	–	–	–	–	8
A-5555-0031	–	8	61	11	74	6	–	29.5	–	–	–	–	–	–	8
A-5555-0032	602030-9016-000	8	62	11	75	6	–	30	–	–	–	–	–	–	8
A-5555-0033	602030-9017-000	8	87	11	100	6	–	40	–	–	–	–	–	–	8
A-5555-0034	600342-8024-000	8	101.5	11	114.5	6	–	45.8	–	–	–	–	–	–	8
A-5555-0035	600342-8124-000	8	92.5	19	114.5	6	–	57.5	–	–	–	–	–	–	8
A-5555-0036	–	9	51.5	11	64.5	6	–	26.3	–	–	–	–	–	–	8
A-5555-0037	600342-8128-000	9	42.5	19	64.5	6	–	36.8	–	–	–	–	–	–	8
A-5555-0038	600342-8029-000	10	52.5	11	65.5	6	–	25.8	–	–	–	–	–	–	8
A-5555-0039	–	10	43.5	19	65.5	6	–	37.8	–	–	–	–	–	–	8
A-5555-0040	602030-9018-000	10	105	11	118	6	–	47.3	–	–	–	–	–	–	8
A-5555-0041	600342-8013-000	5	43	11	53	3.5	–	4.6	–	–	–	–	–	–	14
A-5555-0042	600342-8016-000	6	44	11	54	3.5	–	4.7	–	–	–	–	–	–	14
A-5555-0043	600342-8017-000	7	45	11	55	3.5	–	5	–	–	–	–	–	–	14
A-5555-0044	600342-8014-000	8	50.5	11	63.5	6	–	8.3	–	–	–	–	–	–	14

Codice Renishaw	Codice ZEISS	DK (mm)	ML1/ML (mm)	DG/D (mm)	L (mm)	DS1/DS (mm)	EAL/B (mm)	Peso (g)	A (mm)	Filettatura/ foro (mm)	Filettatura (da/a)	MB (mm)	G1 (mm)	SW (mm)	Pagina n.
A-5555-0045	600342-8018-000	9	51.5	11	64.5	6	–	8.4	–	–	–	–	–	–	14
A-5555-0046	–	9	42.5	19	64.5	6	–	21	–	–	–	–	–	–	14
A-5555-0047	600342-8019-000	10	52.5	11	65.5	6	–	9	–	–	–	–	–	–	14
A-5555-0048	–	10	43.5	19	65.5	6	–	38	–	–	–	–	–	–	14
A-5555-0049	–	8	41.5	19	63.5	6	–	33	–	–	–	–	–	–	14
A-5555-0050	600342-8015-000	8	101.5	11	114.5	6	–	11.8	–	–	–	–	–	–	14
A-5555-0051	–	8	92.5	19	114.5	6	–	38	–	–	–	–	–	–	14
A-5555-0052	602030-8060-000	0.8	4.8/12.0	11	32	0.6/1.0	–	6.8	–	–	–	–	–	–	15
A-5555-0053	602030-8061-000	1	5.0/12.0	11	32	0.8/1.0	–	6.8	–	–	–	–	–	–	15
A-5555-0054	602030-8062-000	1.35	12	11	32	1	–	6.9	–	–	–	–	–	–	15
A-5555-0055	602030-8063-000	1.35	19	11	44	1	–	7.5	–	–	–	–	–	–	15
A-5555-0056	602030-8064-000	1.5	12	11	32	1	–	6.5	–	–	–	–	–	–	15
A-5555-0057	602030-8065-000	1.5	19	11	44	1	–	7.5	–	–	–	–	–	–	15
A-5555-0058	602030-8066-000	2	12	11	32	1.5	–	7.3	–	–	–	–	–	–	15
A-5555-0059	602030-8067-000	2	19	11	44	1.5	–	8	–	–	–	–	–	–	15
A-5555-0060	602030-8068-000	2	33	11	58	1.5	–	8	–	–	–	–	–	–	15
A-5555-0061	602030-8069-000	2.5	12	11	32	1.5	–	7.3	–	–	–	–	–	–	15
A-5555-0062	602030-8070-000	2.5	19	11	44	1.5	–	8	–	–	–	–	–	–	15
A-5555-0063	602030-8071-000	2.5	33	11	58	1.5	–	8	–	–	–	–	–	–	15
A-5555-0064	602030-9019-000	1	5	11	55	0.8	–	11.9	–	–	–	–	–	–	16
A-5555-0065	602030-9020-000	1.5	5	11	55	1	–	11.9	–	–	–	–	–	–	16
A-5555-0066	602030-9021-000	2	5	11	55	1.5	–	11.9	–	–	–	–	–	–	16
A-5555-0067	–	2.5	5	11	55	2	–	11.9	–	–	–	–	–	–	16
A-5555-0068	602030-9023-000	3.5	10	11	55	2.5	–	11.9	–	–	–	–	–	–	16
A-5555-0069	–	1	7	–	45	0.8/2.0	15	17.3	–	–	–	–	–	–	16
A-5555-0070	602030-9025-000	1.5	7.5	–	45	1.0/2.0	15	17.3	–	–	–	–	–	–	16
A-5555-0071	–	2	7.5	–	45	1.5/2.0	15	17.3	–	–	–	–	–	–	16
A-5555-0072	602030-9027-000	2.5	8	–	45	1.5/2.0	15	17.3	–	–	–	–	–	–	16
A-5555-0073	–	3.5	15	–	45	2	15	17.3	–	–	–	–	–	–	16
A-5555-0074	–	1.35	9	11	40	1	2	11	–	–	–	–	–	–	24
A-5555-0075	–	2.3	12	11	40	1	2.5	13	–	–	–	–	–	–	24
A-5555-0076	–	1.8	10	11	40	1	2	12	–	–	–	–	–	–	24
A-5555-0077	–	0.8	5	11	40	0.6	1.9	7	–	–	–	–	–	–	24
A-5555-0078	600342-8200-000	1.35	23.85	11	32.85	1	–	6	–	–	–	–	–	–	17
A-5555-0079	600342-8201-000	1.5	24	11	33	1	–	7	–	–	–	–	–	–	17

Codice Renishaw	Codice ZEISS	DK (mm)	ML1/ML (mm)	DG/D (mm)	L (mm)	DS1/DS (mm)	EAL/B (mm)	Peso (g)	A (mm)	Filettatura/ foro (mm)	Filettatura (da/a)	MB (mm)	G1 (mm)	SW (mm)	Pagina n.
A-5555-0080	600342-8202-000	2	24.5	11	33.5	1	–	7	–	–	–	–	–	–	17
A-5555-0081	600342-8203-000	2.5	25	11	34	1.5	–	7	–	–	–	–	–	–	17
A-5555-0082	600342-8221-000	3	16.5	19	34.5	2	–	20	–	–	–	–	–	–	17
A-5555-0083	600342-8222-000	5	25.5	19	43.5	3.5	–	23	–	–	–	–	–	–	17
A-5555-0084	600342-8250-000	0.3	2.3/12.8	11	21.8	0.2/1.0	–	6	–	–	–	–	–	–	17
A-5555-0085	600342-8251-000	0.5	2.5/13.0	11	22	0.3/1.0	–	6	–	–	–	–	–	–	17
A-5555-0086	600342-8252-000	0.6	4.6/13.1	11	22.1	0.4/1.0	–	6	–	–	–	–	–	–	17
A-5555-0087	600342-8253-000	0.8	4.8/13.3	11	22.3	0.6/1.0	–	6	–	–	–	–	–	–	17
A-5555-0088	600342-8254-000	1	5.0/13.5	11	22.5	0.8/1.0	–	6	–	–	–	–	–	–	17
A-5555-0089	600341-0140-000	–	–	11	–	–	1.5	1	–	–	–	–	–	–	19
A-5555-0090	600341-0141-000	–	–	19	–	–	2	4	–	–	–	–	–	–	19
A-5555-0091	600341-0150-000	–	–	11	–	–	2	1	–	–	–	–	–	–	19
A-5555-0092	600341-0151-000	–	–	19	–	–	4	7	–	–	–	–	–	–	19
A-5555-0093	600341-0520-000	–	–	1	10	–	–	1	–	–	–	–	–	–	19
A-5555-0094	600341-0521-000	–	–	1.5	10	–	–	1	–	–	–	–	–	–	19
A-5555-0095	600341-0522-000	–	–	2	18	–	–	1	–	–	–	–	–	–	19
A-5555-0096	600341-0523-000	–	–	3.5	18	–	–	3	–	–	–	–	–	–	19
A-5555-0099	–	–	–	18	30	–	–	43	–	–	–	–	–	–	26
A-5555-0104	600341-8160-000	–	–	11	45	1-1.5/6	–	16	–	–	–	–	–	–	21
A-5555-0105	600341-8367-000	–	–	11	10	1	–	3.2	–	–	–	–	–	–	21
A-5555-0106	600341-8368-000	–	–	11	10	1.5	–	3.2	–	–	–	–	–	–	21
A-5555-0107	600341-8454-000	1	5	–	16	0.8/1.0	–	1	–	–	–	–	–	–	20
A-5555-0108	600341-8450-000	0.3	2.3	–	15.3	0.2/1.0	–	1	–	–	–	–	–	–	20
A-5555-0109	600341-8451-000	0.5	2.5	–	15.5	0.3/1.0	–	1	–	–	–	–	–	–	20
A-5555-0110	600341-8452-000	0.6	4.6	–	15.6	0.4/1.0	–	1	–	–	–	–	–	–	20
A-5555-0111	600341-8453-000	0.8	4.8	–	15.8	0.6/1.0	–	1	–	–	–	–	–	–	20
A-5555-0112	600341-8500-000	1.35	–	–	26.35	1	–	1	–	–	–	–	–	–	20
A-5555-0113	600341-8501-000	1.5	–	–	26.5	1	–	1	–	–	–	–	–	–	20
A-5555-0114	600341-8502-000	2	–	–	27	1.5	–	1	–	–	–	–	–	–	20
A-5555-0115	600341-8503-000	2.5	–	–	27.5	1.5	–	1	–	–	–	–	–	–	20
A-5555-0116	600341-8510-000	3	–	–	38	2	–	2	–	–	–	–	–	–	20
A-5555-0117	600341-8511-000	5	–	–	45	3.5	–	6	–	–	–	–	–	–	20
A-5555-0118	600341-8180-000	–	–	11	40	1-1.5/6	–	15	–	–	–	–	–	–	22
A-5555-0118	626105-6901-001	–	–	11	40	1-1.5/6	–	15	–	–	–	–	–	–	22
A-5555-0119	600341-8183-000	1	5	1	17.5	0.8/1.0	–	1	–	–	–	–	–	–	22

Codice Renishaw	Codice ZEISS	DK (mm)	ML1/ML (mm)	DG/D (mm)	L (mm)	DS1/DS (mm)	EAL/B (mm)	Peso (g)	A (mm)	Filettatura/ foro (mm)	Filettatura (da/a)	MB (mm)	G1 (mm)	SW (mm)	Pagina n.
A-5555-0120	600341-8185-000	2	24.5	1.5	28.5	1.5	—	1	—	—	—	—	—	—	22
A-5555-0121	600341-8090-000	10	—	7	21.5	—	1.5	3	—	—	—	—	—	—	23
A-5555-0122	600341-8095-000	15	—	10	21.5	—	1.5	6	—	—	—	—	—	—	23
A-5555-0123	602030-8091-000	20	—	7	60	—	1	8	—	—	—	—	—	—	23
A-5555-0124	000000-1165-629	15	—	7	40	—	1	5	—	—	—	—	—	—	23
A-5555-0125	600341-8423-000	—	—	20	200	—	—	84.7	—	—	—	—	—	—	33
A-5555-0126	600341-8421-000	—	—	20	150	—	—	67.4	—	—	—	—	—	—	33
A-5555-0127	600341-8422-000	—	—	20	100	—	—	50.7	—	—	—	—	—	—	33
A-5555-0128	600341-8423-000	—	—	20	80	—	—	44.8	—	—	—	—	—	—	33
A-5555-0129	600341-8424-000	—	—	20	60	—	—	37.7	—	—	—	—	—	—	33
A-5555-0130	600341-8425-000	—	—	20	40	—	—	29	—	—	—	—	—	—	33
A-5555-0131	600341-8265-000	—	—	11	120	—	—	30.9	—	—	—	—	—	—	33
A-5555-0132	600341-8264-000	—	—	11	100	—	—	25.6	—	—	—	—	—	—	33
A-5555-0133	600341-8263-000	—	—	11	80	—	—	20.6	—	—	—	—	—	—	33
A-5555-0134	600341-8262-000	—	—	11	60	—	—	15.4	—	—	—	—	—	—	33
A-5555-0135	600341-8261-000	—	—	11	40	—	—	10.3	—	—	—	—	—	—	33
A-5555-0136	600341-0260-000	—	—	11	100	—	—	73	—	—	—	—	—	—	33
A-5555-0137	600341-0258-000	—	—	11	80	—	—	58	—	—	—	—	—	—	33
A-5555-0138	600341-0256-000	—	—	11	60	—	—	42	—	—	—	—	—	—	33
A-5555-0139	600341-0254-000	—	—	11	40	—	—	28	—	—	—	—	—	—	33
A-5555-0140	600341-0252-000	—	—	11	20	—	—	13	—	—	—	—	—	—	33
A-5555-0141	600341-0251-000	—	—	11	15	—	—	9	—	—	—	—	—	—	33
A-5555-0142	600341-0250-000	—	—	11	10	—	—	6	—	—	—	—	—	—	33
A-5555-0143	602030-9044-000	—	—	11	10	—	—	3.6	—	—	—	—	—	—	31
A-5555-0144	602030-9045-000	—	—	11	15	—	—	5.7	—	—	—	—	—	—	31
A-5555-0145	602030-9046-000	—	—	11	20	—	—	7.8	—	—	—	—	—	—	31
A-5555-0146	602030-9047-000	—	—	11	25	—	—	9.7	—	—	—	—	—	—	31
A-5555-0147	602030-9048-000	—	—	18	25	—	—	27.3	—	—	—	—	—	—	31
A-5555-0148	602030-9049-000	—	—	11	40	—	—	16.1	—	—	—	—	—	—	31
A-5555-0149	602030-9050-000	—	—	18	40	—	—	44.7	—	—	—	—	—	—	31
A-5555-0150	602030-9051-000	—	—	11	50	—	—	12.7	—	—	—	—	—	—	31
A-5555-0151	602030-9052-000	—	—	18	50	—	—	36.3	—	—	—	—	—	—	31
A-5555-0152	602030-9051-000	—	—	11	60	—	—	12.7	—	—	—	—	—	—	31
A-5555-0153	602030-9054-000	—	—	18	60	—	—	38.3	—	—	—	—	—	—	31
A-5555-0154	602030-9055-000	—	—	11	75	—	—	15	—	—	—	—	—	—	31

Codice Renishaw	Codice ZEISS	DK (mm)	ML1/ML (mm)	DG/D (mm)	L (mm)	DS1/DS (mm)	EAL/B (mm)	Peso (g)	A (mm)	Filettatura/ foro (mm)	Filettatura (da/a)	MB (mm)	G1 (mm)	SW (mm)	Pagina n.
A-5555-0155	602030-9056-000	–	–	18	75	–	–	42.8	–	–	–	–	–	–	31
A-5555-0156	602030-9057-000	–	–	11	80	–	–	15.6	–	–	–	–	–	–	31
A-5555-0157	602030-9058-000	–	–	18	80	–	–	44.2	–	–	–	–	–	–	31
A-5555-0158	602030-9059-000	–	–	11	90	–	–	16.2	–	–	–	–	–	–	31
A-5555-0159	602030-9060-000	–	–	18	90	–	–	47.3	–	–	–	–	–	–	31
A-5555-0160	602030-9061-000	–	–	11	100	–	–	17.3	–	–	–	–	–	–	31
A-5555-0161	602030-9062-000	–	–	18	100	–	–	49.4	–	–	–	–	–	–	31
A-5555-0162	602030-9063-000	–	–	11	120	–	–	19.4	–	–	–	–	–	–	31
A-5555-0163	602030-9064-000	–	–	18	120	–	–	55.1	–	–	–	–	–	–	31
A-5555-0164	602030-9065-000	–	–	11	150	–	–	22.4	–	–	–	–	–	–	31
A-5555-0165	602030-9066-000	–	–	18	150	–	–	65	–	–	–	–	–	–	31
A-5555-0166	602030-9067-000	–	–	18	200	–	–	79.3	–	–	–	–	–	–	31
A-5555-0167	602030-9068-000	–	–	18	250	–	–	92.4	–	–	–	–	–	–	31
A-5555-0168	602030-9069-000	–	–	18	300	–	–	107	–	–	–	–	–	–	31
A-5555-0189	600341-8361-000	–	–	–	–	–	15	12.6	–	–	–	–	–	–	27
A-5555-0190	600341-8002-000	–	–	–	–	–	20	31.5	–	–	–	–	–	–	27
A-5555-0191	602030-8363-000	–	–	–	–	–	15	7.5	–	–	–	–	–	–	28
A-5555-0192	602030-8362-000	–	–	–	–	–	20	20	–	–	–	–	–	–	28
A-5555-0194	–	–	–	–	40	–	20	64	–	–	–	–	–	–	30
A-5555-0196	602030-0004-000	15	–	–	–	–	4	5	–	M5	–	–	–	–	26
A-5555-0197	602030-0005-000	20	–	–	–	–	4	9	–	M5	–	–	–	–	26
A-5555-0198	602030-0006-000	30	–	–	–	–	4	21	–	M5	–	–	–	–	26
A-5555-0199	602030-0007-000	40	–	–	–	–	5	42	–	M5	–	–	–	–	26
A-5555-0200	602030-0008-000	50	–	–	–	–	5	64	–	M5	–	–	–	–	26
A-5555-0201	602030-0009-000	60	–	–	–	–	5	89	–	M5	–	–	–	–	26
A-5555-0203	602030-0011-000	20	–	–	–	–	4	8	–	8	–	–	–	–	26
A-5555-0204	600341-0200-000	20	–	–	–	–	2	4	–	8	–	–	–	–	26
A-5555-0205	600341-0203-000	30	–	–	–	–	4	10	–	8	–	–	–	–	26
A-5555-0206	600341-0204-000	40	–	–	–	–	4	21	–	8	–	–	–	–	26
A-5555-0207	600341-0205-000	50	–	–	–	–	5	36	–	8	–	–	–	–	26
A-5555-0208	600341-0206-000	60	–	–	–	–	6	59	–	8	–	–	–	–	26
A-5555-0209	–	–	10	10	16	–	–	4	–	–	–	1.8	M4	–	34
A-5555-0210	–	–	10	10	16	–	–	4	–	–	–	1.8	M5	–	34
A-5555-0211	–	–	12	12	18	–	–	7	–	–	–	1.8	M6	–	34
A-5555-0212	–	–	12	15	20	–	–	13	–	–	–	3	M8	–	34

Codice Renishaw	Codice ZEISS	DK (mm)	ML1/ML (mm)	DG/D (mm)	L (mm)	DS1/DS (mm)	EAL/B (mm)	Peso (g)	A (mm)	Filettatura/ foro (mm)	Filettatura (da/a)	MB (mm)	G1 (mm)	SW (mm)	Pagina n.
A-5555-0213	–	–	15	18	25	–	–	25	–	–	–	3	M10	–	34
A-5555-0214	–	–	15	20	25	–	–	33	–	–	–	3	M12	–	34
A-5555-0215	600331-8093-000	5	–	19	80	3.5	–	70	–	–	–	–	–	–	25
A-5555-0216	600342-8051-000	30°	39	11	61	3.5	–	12	–	–	–	–	–	–	24
A-5555-0217	–	–	–	–	120	–	20	87	–	–	–	–	–	–	30
A-5555-0218	600342-9002-000	–	–	11	30	–	–	11.2	–	–	–	–	–	–	27
A-5555-0219	–	–	–	18	36	–	–	37.2	–	–	–	–	–	–	27
A-5555-0221	600341-0210	–	26	–	35	–	–	9	–	–	–	–	–	–	34
A-5555-0222	600341-0211	–	21	–	30	–	–	9	–	–	–	–	–	–	34
A-5555-0223	600341-0212	–	9	–	17.5	–	–	7	–	–	–	–	–	–	34
A-5555-0224	–	–	26	–	–	–	–	4	–	–	–	–	–	–	34
A-5555-0225	–	–	21	–	–	–	–	3	–	–	–	–	–	–	34
A-5555-0226	602030-0215-000	–	–	11	10	–	–	5.2	–	–	M5/M2	–	–	–	35
A-5555-0227	602030-0315-000	–	–	11	10	–	–	5.2	–	–	M5/M3	–	–	–	35
A-5555-0228	–	–	–	11	10	–	–	5.2	–	–	M5/M4	–	–	–	35
A-5555-0231	–	–	–	15.81	119	–	–	126	M2	–	–	–	–	–	35
A-5555-0232	602030-9115-000	–	–	9.52	127	–	–	87	M2	–	–	–	–	–	35
A-5555-0233	602030-0001-000	–	–	1.2	23	–	–	1	–	–	–	–	–	–	59
A-5555-0234	602030-0002-000	–	–	–	–	–	1.5	–	–	–	–	–	–	–	60
A-5555-0235	602030-0042-000	–	–	–	–	–	0.9	–	–	–	–	–	–	–	60
A-5555-0236	602030-0021-000	–	–	–	–	–	2.5	–	–	–	–	–	–	–	60
A-5555-0238	600341-8596-000	–	–	2.9	70	–	–	–	–	–	–	–	–	–	36
A-5555-0240	000000-0015-323	–	–	2.9	70	–	–	–	–	–	–	–	–	–	36
A-5555-0251	600660-8251-000	–	–	–	–	–	–	144	–	–	–	–	–	–	38
A-5555-0253	620660-8251-000	–	–	–	–	–	–	144	–	–	–	–	–	–	39
A-5555-0255	600667-9601-000	–	–	–	–	–	–	153	–	–	–	–	–	–	38
A-5555-0256	600667-9611-000	–	–	–	–	–	–	306	–	–	–	–	–	–	38
A-5555-0258	626107-2000-940	–	–	–	–	–	–	130	–	–	–	–	–	–	38
A-5555-0261	602030-8104-000	2	14	4	22	1	–	1	–	–	–	–	–	–	55
A-5555-0262	602030-8113-000	3	21.5	5.5	40	2	–	4	–	–	–	–	–	–	55
A-5555-0264	602030-8102-000	4	26	4	32	2	–	1	–	–	–	–	–	–	56
A-5555-0266	602030-8101-000	5	24.5	4	32.5	2	–	1	–	–	–	–	–	–	56
A-5555-0267	602030-8115-000	0.5	2.5/11.25	4	21.25	0.3/1.0	–	1	–	–	–	–	–	–	55
A-5555-0268	602030-8116-000	0.6	4.6/9.0	4	22	0.4/1.0	–	1	–	–	–	–	–	–	55
A-5555-0269	602030-8117-000	0.8	4.8/9.0	4	22	0.4/1.0	–	1	–	–	–	–	–	–	55

Codice Renishaw	Codice ZEISS	DK (mm)	ML1/ML (mm)	DG/D (mm)	L (mm)	DS1/DS (mm)	EAL/B (mm)	Peso (g)	A (mm)	Filettatura/ foro (mm)	Filettatura (da/a)	MB (mm)	G1 (mm)	SW (mm)	Pagina n.
A-5555-0270	602030-8118-000	1	5.0/9.0	4	22	0.8/1.0	–	1	–	–	–	–	–	–	55
A-5555-0271	602030-8119-000	1.5	9	4	22	1	–	1	–	–	–	–	–	–	55
A-5555-0272	602030-8120-000	1	5.0/5.5	4	10.5	0.8/1.0	–	1	–	–	–	–	–	–	55
A-5555-0273	602030-8121-000	0.3	2.3/9.0	4	22	0.2/1.0	–	1	–	–	–	–	–	–	55
A-5555-0274	602030-8023-000	2	15	4	21	1	–	1	–	–	–	–	–	–	55
A-5555-0275	602030-8020-000	6	9	4	13	2	–	1	–	–	–	–	–	–	56
A-5555-0276	602030-8021-000	3	15.5	4	21.5	1.5	–	1	–	–	–	–	–	–	55
A-5555-0277	602030-8106-000	3	13	4	21	2	–	1	–	–	–	–	–	–	55
A-5555-0278	602030-8002-000	6	9	3	13	2	–	1	–	–	–	–	–	–	62
A-5555-0279	–	5	16.5	3	22.5	2	–	1	–	–	–	–	–	–	62
A-5555-0282	602030-8001-000	2	5	3	11	1	–	1	–	–	–	–	–	–	61
A-5555-0283	602030-8034-000	5	16.5	3	22.5	2	–	1	–	–	–	–	–	–	61
A-5555-0286	602030-8303-000	–	–	4	30	–	–	2.6	–	–	–	–	–	–	58
A-5555-0287	602030-8304-000	–	–	4	40	–	–	3.7	–	–	–	–	–	–	58
A-5555-0288	602030-8305-000	–	–	4	50	–	–	4.7	–	–	–	–	–	–	58
A-5555-0294	602030-8011-000	2	9.5	–	32	1.4	5.5	1	–	–	–	–	–	–	63
A-5555-0295	602030-8010-000	2	4.5	–	22	1.4	5.5	1	–	–	–	–	–	–	63
A-5555-0296	602030-8012-000	2	13.5	3	19.5	1.5	–	1	–	–	–	–	–	–	64
A-5555-0297	602030-8201-000	8	19	3	32	1.5	1.5	1	–	–	–	–	–	–	64
A-5555-0298	602030-8202-000	4	19	3	32	1	1	1	–	–	–	–	–	–	64
A-5555-0299	602030-8203-000	14	–	–	5.5	–	2	1	–	–	–	–	–	–	65
A-5555-0300	602030-8204-000	20	–	–	5.5	–	2.5	3	–	–	–	–	–	–	65
A-5555-0303	602030-8382-000	–	–	–	11.5	–	12	4.2	–	–	–	–	–	–	58
A-5555-0306	602030-8345-000	–	–	4	5	–	–	0.5	–	–	M2/M3	–	–	–	59
A-5555-0307	000000-1018-201	–	–	–	–	–	–	–	–	–	–	–	–	–	60
A-5555-0308	602030-8006-000	1	6.5	3	10.5	0.8	–	0.3	–	–	–	–	–	–	61
A-5555-0309	–	1	11.5	3	15.5	0.8	–	0.3	–	–	–	–	–	–	61
A-5555-0310	602030-8008-000	2	7	3	16	1	–	1	–	–	–	–	–	–	61
A-5555-0311	602030-8009-000	2	12	3	16	1	–	1	–	–	–	–	–	–	61
A-5555-0312	602030-8015-000	4	6	3	12	1	–	1	–	–	–	–	–	–	61
A-5555-0313	602030-8016-000	4	16	3	22	2	–	1	–	–	–	–	–	–	61
A-5555-0314	–	6	13	3	13	3	–	0.9	–	–	–	–	–	–	63
A-5555-0315	–	6	28	3	28	3	–	1.8	–	–	–	–	–	–	63
A-5555-0316	–	8	13	3	13	3	–	2	–	–	–	–	–	–	63
A-5555-0319	602030-9104-000	–	–	–	9.1	–	10.5	3.4	–	–	–	–	–	–	67

Codice Renishaw	Codice ZEISS	DK (mm)	ML1/ML (mm)	DG/D (mm)	L (mm)	DS1/DS (mm)	EAL/B (mm)	Peso (g)	A (mm)	Filettatura/ foro (mm)	Filettatura (da/a)	MB (mm)	G1 (mm)	SW (mm)	Pagina n.
A-5555-0320	602030-9103-000	–	–	–	5.4	–	7	1	–	–	–	–	–	–	67
A-5555-0322	–	–	–	–	–	–	–	72	–	–	–	–	–	–	38
A-5555-0328	000000-0015-245	–	–	–	–	–	2	–	–	–	–	–	–	–	60
A-5555-0329	626115-0150-033	1.5	24	11	33	1	–	7	–	–	–	–	–	–	18
A-5555-0331	626115-0030-022	0.3	2.3/12.8	11	21.8	0.2/1.0	–	6	–	–	–	–	–	–	18
A-5555-0410	626105-0510-100	5	90	11	100	3.5	–	5.4	–	–	–	–	–	–	12
A-5555-0424	626107-1150-100	–	–	11	150	–	–	17	–	–	–	–	–	–	32
A-5555-0425	626107-1120-100	–	–	11	120	–	–	15	–	–	–	–	–	–	32
A-5555-0427	626107-2250-100	–	–	20	250	–	–	55	–	–	–	–	–	–	32
A-5555-0498	612030-9661-000	4.5	43	11	53	3.5	–	8	–	–	–	–	–	–	8
A-5555-0619	–	–	–	11	35	–	–	13.9	–	–	–	–	–	–	31
A-5555-0620	626107-2040-100	–	–	20	40	–	–	26	–	–	–	–	–	–	32
A-5555-0621	626107-2080-100	–	–	20	80	–	–	32	–	–	–	–	–	–	32
A-5555-0623	626107-1070-100	–	–	11	70	–	–	11	–	–	–	–	–	–	32
A-5555-0642	626107-1300-100	–	–	11	300	–	–	27	–	–	–	–	–	–	32
A-5555-0643	626105-1020-150	10	137	11	150	6	–	16	–	–	–	–	–	–	13
A-5555-0644	626105-1020-200	10	187	11	200	6	–	19	–	–	–	–	–	–	13
A-5555-0647	626107-1040-100	–	–	11	40	–	–	9	–	–	–	–	–	–	32
A-5555-0648	626107-1050-100	–	–	11	50	–	–	10	–	–	–	–	–	–	32
A-5555-0649	626107-1060-100	–	–	11	60	–	–	11	–	–	–	–	–	–	32
A-5555-0650	626107-1080-100	–	–	11	80	–	–	12	–	–	–	–	–	–	32
A-5555-0651	626107-1090-100	–	–	11	90	–	–	13	–	–	–	–	–	–	32
A-5555-0652	626107-1100-100	–	–	11	100	–	–	14	–	–	–	–	–	–	32
A-5555-0653	626107-1180-100	–	–	11	180	–	–	19	–	–	–	–	–	–	32
A-5555-0654	626107-1200-100	–	–	11	200	–	–	21	–	–	–	–	–	–	32
A-5555-0655	626107-1250-100	–	–	11	250	–	–	24	–	–	–	–	–	–	32
A-5555-0656	626107-1400-100	–	–	11	400	–	–	34	–	–	–	–	–	–	32
A-5555-0657	626107-2050-100	–	–	20	50	–	–	28	–	–	–	–	–	–	32
A-5555-0658	626107-2060-100	–	–	20	60	–	–	29	–	–	–	–	–	–	32
A-5555-0659	626107-2100-100	–	–	20	100	–	–	34	–	–	–	–	–	–	32
A-5555-0660	626107-2120-100	–	–	20	120	–	–	37	–	–	–	–	–	–	32
A-5555-0661	626107-2150-100	–	–	20	150	–	–	41	–	–	–	–	–	–	32
A-5555-0662	626107-2180-100	–	–	20	180	–	–	45	–	–	–	–	–	–	32
A-5555-0663	626107-2200-100	–	–	20	200	–	–	48	–	–	–	–	–	–	32
A-5555-0664	626107-2300-100	–	–	20	300	–	–	62	–	–	–	–	–	–	32

Codice Renishaw	Codice ZEISS	DK (mm)	ML1/ML (mm)	DG/D (mm)	L (mm)	DS1/DS (mm)	EAL/B (mm)	Peso (g)	A (mm)	Filettatura/ foro (mm)	Filettatura (da/a)	MB (mm)	G1 (mm)	SW (mm)	Pagina n.
A-5555-0665	626107-2400-100	–	–	20	400	–	–	75	–	–	–	–	–	–	32
A-5555-0667	626107-2500-100	–	–	20	500	–	–	89	–	–	–	–	–	–	32
A-5555-0668	626107-2600-100	–	–	20	600	–	–	103	–	–	–	–	–	–	32
A-5555-0671	–	–	–	20	50	–	–	33.3	–	–	–	–	–	–	33
A-5555-0686	626115-0250-034	2.5	25	11	34	1.5	–	7	–	–	–	–	–	–	18
A-5555-0699	626107-2025-130	–	66.5	20	25	–	15	60	–	–	–	–	–	–	40
A-5555-0700	626107-2080-130	–	121.5	20	80	–	15	68	–	–	–	–	–	–	40
A-5555-0701	626107-2150-130	–	191.5	20	150	–	15	77	–	–	–	–	–	–	40
A-5555-0713	–	–	–	11	29	–	–	13	–	–	–	–	–	–	26
A-5555-0720	626105-0821-063	8	50.5	11	63.5	6	–	7	–	–	–	–	–	–	13
A-5555-0730	626105-0300-050	3	40	11	50	2	–	4.5	–	–	–	–	–	–	12
A-5555-0731	626105-0400-064	4	54	11	64	2	–	4.6	–	–	–	–	–	–	12
A-5555-0732	626105-0510-050	5	40	11	50	3.5	–	4.8	–	–	–	–	–	–	12
A-5555-0733	626105-0610-054	6	44	11	54	3.5	–	4.9	–	–	–	–	–	–	12
A-5555-0734	626105-0710-055	7	45	11	55	3.5	–	4.9	–	–	–	–	–	–	12
A-5555-0735	626105-0510-075	5	65	11	75	3.5	–	5	–	–	–	–	–	–	12
A-5555-0799	626115-0140-033	1.35	23.85	11	32.85	1	–	6	–	–	–	–	–	–	18
A-5555-0805	–	5	20	11	30	3.5	–	8	–	–	–	–	–	–	8
A-5555-0946	–	8	137	11	150	6	–	60	–	–	–	–	–	–	8
A-5555-0950	000000-1251-674	–	–	11	30	–	–	12.1	–	–	–	–	–	–	31
A-5555-0952	–	2	30	11	40	1.5	–	7	–	–	–	–	–	–	7
A-5555-0965	–	1.5	7.0/24.0	11	33	1.0/1.5	–	7	–	–	–	–	–	–	18
A-5555-0974	–	4	20	11	30	2	–	4.4	–	–	–	–	–	–	7
A-5555-1027	626105-1020-065	10	52.5	11	65.5	6	–	8	–	–	–	–	–	–	12
A-5555-1054	–	1	5.0/15.0	11	25	0.8/1.0	–	6	–	–	–	–	–	–	7
A-5555-1060	–	2	20	11	30	1.5	–	7	–	–	–	–	–	–	7
A-5555-1065	626105-0511-100	5	90	11	100	3.5	–	5.4	–	–	–	–	–	–	13
A-5555-1077	–	2	10	11	20	1	–	6	–	–	–	–	–	–	7
A-5555-1093	–	–	–	11	51	–	–	19	–	–	–	–	–	–	27
A-5555-1095	000000-1120-407	0.6	4.6/12.0	11	32	0.4/1.0	–	6.5	–	–	–	–	–	–	15
A-5555-1097	626105-6901-001	–	17	11	22.5	–	–	6	–	–	–	–	–	–	22
A-5555-1101	–	0.5	2.5/13.5	3	18	0.3/1.0	–	0.4	–	–	–	–	–	–	61
A-5555-1112	626105-0820-200	8	187	11	200	6	–	13	–	–	–	–	–	–	12
A-5555-1114	626103-0501-075	5	66	5	75	3.5	–	1.8	–	–	–	–	–	–	43
A-5555-1115	626103-0600-100	6	91	5	100	3.5	–	2.4	–	–	–	–	–	–	43

Codice Renishaw	Codice ZEISS	DK (mm)	ML1/ML (mm)	DG/D (mm)	L (mm)	DS1/DS (mm)	EAL/B (mm)	Peso (g)	A (mm)	Filettatura/ foro (mm)	Filettatura (da/a)	MB (mm)	G1 (mm)	SW (mm)	Pagina n.
A-5555-1118	–	6	42	4	50	2	–	3.2	–	–	–	–	–	–	56
A-5555-1135	–	0.8	30	11	40	0.6/4.0	–	9	8	–	–	–	–	–	25
A-5555-1141	–	0.2	2.3	–	15.2	0.18/1.0	–	1	–	–	–	–	–	–	20
A-5555-1153	–	0.6	30	11	40	0.4/4.0	–	9	8	–	–	–	–	–	25
A-5555-1157	626115-0050-022	0.5	2.5/13.0	11	22	0.3/1.0	–	6	–	–	–	–	–	–	18
A-5555-1169	626105-0821-150	8	137	11	150	6	–	11	–	–	–	–	–	–	14
A-5555-1171	626105-1021-200	10	187	11	200	6	–	19	–	–	–	–	–	–	14
A-5555-1179	626105-0821-200	8	187	11	200	6	–	13	–	–	–	–	–	–	14
A-5555-1235	620161-8055-000	–	–	–	–	–	–	–	–	–	–	–	–	–	49
A-5555-1236	620161-8058-000	–	–	–	–	–	–	–	–	–	–	–	–	–	49
A-5555-1237	620161-8065-000	–	–	–	75	–	–	5.4	–	–	–	–	–	–	50
A-5555-1238	620161-8068-000	–	–	–	75	–	–	5.4	–	–	–	–	–	–	50
A-5555-1239	620161-8075-000	–	–	–	–	–	–	–	–	–	–	–	–	–	50
A-5555-1240	620161-8078-000	–	–	–	–	–	–	–	–	–	–	–	–	–	51
A-5555-1241	626103-8031-055	–	–	–	55	–	–	6.3	–	–	–	–	–	–	49
A-5555-1242	626103-8033-055	–	–	–	55	–	–	6.3	–	–	–	–	–	–	51
A-5555-1245	626115-5000-199	–	–	11	10	2	–	3.2	–	–	–	–	–	–	21
A-5555-1251	626103-0300-040	3	31	5	40	2	–	0.8	–	–	–	–	–	–	43
A-5555-1271	–	5	90	11	100	3.5	–	15	–	–	–	–	–	–	8
A-5555-1273	626103-0302-020	3	11	5	20	2	–	0.8	–	–	–	–	–	–	45
A-5555-1274	626103-0302-030	3	21	5	30	2	–	0.9	–	–	–	–	–	–	45
A-5555-1275	626103-0302-040	3	31	5	40	2	–	1	–	–	–	–	–	–	45
A-5555-1276	626103-5150-000	–	–	5	150	–	–	2.7	–	–	–	–	–	–	48
A-5555-1277	–	0.7	4.6	–	15.7	0.4/1.0	–	1	–	–	–	–	–	–	20
A-5555-1308	–	–	–	3	35	–	–	1.8	–	–	–	–	–	–	66
A-5555-1425	–	3.5	85	11	100	2.5	–	7	–	–	–	–	–	–	7
A-5555-1478	626115-6110-001	–	–	–	–	–	15	12.6	–	–	–	–	–	–	27
A-5555-1495	–	1	20	11	30	0.8	–	6	–	–	–	–	–	–	7
A-5555-1508	–	3.5	48	11	58	2	–	6	–	–	–	–	–	–	7
A-5555-1551	–	–	–	–	–	–	15	13	–	–	–	–	–	–	28
A-5555-1563	–	2	15	11	25	1	–	6	–	–	–	–	–	–	7
A-5555-1618	–	8	40	11	50	5	–	24	–	–	–	–	–	–	8
A-5555-1628	626115-1200-118	12	105	11	118	6	–	49	–	–	–	–	–	–	8
A-5555-1679	–	1	5.0/10.0	11	20	0.8/1.0	–	6	–	–	–	–	–	–	7
A-5555-1773	–	0.5	2.5/12.0	11	32	0.3/1.0	–	6.5	–	–	–	–	–	–	15

Codice Renishaw	Codice ZEISS	DK (mm)	ML1/ML (mm)	DG/D (mm)	L (mm)	DS1/DS (mm)	EAL/B (mm)	Peso (g)	A (mm)	Filettatura/ foro (mm)	Filettatura (da/a)	MB (mm)	G1 (mm)	SW (mm)	Pagina n.
A-5555-1828	626105-0301-033	3	23.5	11	33.5	2	—	4.2	—	—	—	—	—	—	13
A-5555-1842	626115-0060-022	0.6	1.6/13.1	11	22.1	0.4/1.0	—	6	—	—	—	—	—	—	18
A-5555-1843	626115-0100-022	1	5.0/13.5	11	22.5	0.8/1.0	—	6	—	—	—	—	—	—	18
A-5555-1844	626115-0080-022	0.8	4.8/13.3	11	22.3	0.6/1.0	—	6	—	—	—	—	—	—	18
A-5555-1847	626105-0300-033	3	23.5	11	33.5	2	—	4.2	—	—	—	—	—	—	12
A-5555-1855	626107-2050-110	—	96.5	20	50	—	20	78	—	—	—	—	—	—	40
A-5555-1892	626115-6110-002	—	—	—	—	—	15	13	—	—	—	—	—	—	28
A-5555-1916	626105-0300-025	3	15	11	25	2	—	4	—	—	—	—	—	—	12
A-5555-1917	626105-0400-033	4	23.5	11	33.5	2	—	4.2	—	—	—	—	—	—	12
A-5555-1918	626105-0820-100	8	87	11	100	6	—	7.5	—	—	—	—	—	—	12
A-5555-1937	626107-2150-110	—	196.5	20	150	—	20	91	—	—	—	—	—	—	40
A-5555-1938	626107-2120-110	—	166.5	20	120	—	20	86	—	—	—	—	—	—	40
A-5555-1947	626103-5025-000	—	—	5	25	—	—	1.25	—	—	—	—	—	—	48
A-5555-1948	626103-5075-000	—	—	5	75	—	—	1.7	—	—	—	—	—	—	48
A-5555-1979	626107-2025-110	—	71.5	20	25	—	20	74	—	—	—	—	—	—	40
A-5555-1980	626107-2040-110	—	86.5	20	40	—	20	76	—	—	—	—	—	—	40
A-5555-1981	626107-2060-110	—	106.5	20	60	—	20	80	—	—	—	—	—	—	40
A-5555-1982	626107-2080-110	—	126.5	20	80	—	20	82	—	—	—	—	—	—	40
A-5555-1983	626107-2100-110	—	146.5	20	100	—	20	84	—	—	—	—	—	—	40
A-5555-1984	626107-2200-110	—	246.5	20	200	—	20	98	—	—	—	—	—	—	40
A-5555-1985	626107-2040-130	—	81.5	20	40	—	15	62	—	—	—	—	—	—	40
A-5555-1986	626107-2050-130	—	91.5	20	50	—	15	64	—	—	—	—	—	—	40
A-5555-1987	626107-2060-130	—	101.5	20	60	—	15	64	—	—	—	—	—	—	40
A-5555-1988	626107-2100-130	—	141.5	20	100	—	15	70	—	—	—	—	—	—	40
A-5555-1989	626107-2120-130	—	161.5	20	120	—	15	72	—	—	—	—	—	—	40
A-5555-1990	626107-2200-130	—	241.5	20	200	—	15	84	—	—	—	—	—	—	40
A-5555-2012	626105-0511-075	5	65	11	75	3.5	—	5	—	—	—	—	—	—	13
A-5555-2013	—	5	43	11	53	3.5	—	4.9	—	—	—	—	—	—	12
A-5555-2033	626103-0501-030	5	21	5	30	3.5	—	1.1	—	—	—	—	—	—	42
A-5555-2144	—	15	52.5	11	65.5	6	—	29	—	—	—	—	—	—	8
A-5555-2270	—	15	105	11	118	6	—	50	—	—	—	—	—	—	8
A-5555-2388	—	1	10	11	20	0.8	—	6	—	—	—	—	—	—	7
A-5555-2389	—	10	137	11	150	6	—	62	—	—	—	—	—	—	8
A-5555-2390	—	10	175	11	200	6	—	75	—	—	—	—	—	—	8
A-5555-2391	—	12	52	11	65.5	6	—	28	—	—	—	—	—	—	8

Codice Renishaw	Codice ZEISS	DK (mm)	ML1/ML (mm)	DG/D (mm)	L (mm)	DS1/DS (mm)	EAL/B (mm)	Peso (g)	A (mm)	Filettatura/ foro (mm)	Filettatura (da/a)	MB (mm)	G1 (mm)	SW (mm)	Pagina n.
A-5555-2392	–	12	175	11	200	6	–	76	–	–	–	–	–	–	8
A-5555-2394	000000-1078-483	3	23.5	11	33.5	2	–	4.5	–	–	–	–	–	–	9
A-5555-2395	612030-9649-000	8	50.5	11	63.5	6	–	25	–	–	–	–	–	–	9
A-5555-2396	626105-0401-064	4	54	11	64	2	–	4.6	–	–	–	–	–	–	13
A-5555-2397	–	5	43	11	53	3.5	–	4.9	–	–	–	–	–	–	13
A-5555-2398	–	6	44	11	54	3.5	–	4.9	–	–	–	–	–	–	13
A-5555-2399	–	7	45	11	55.5	3.5	–	4.9	–	–	–	–	–	–	13
A-5555-2400	–	8	62	11	75	6	–	7.3	–	–	–	–	–	–	13
A-5555-2402	–	9	51.5	11	64.5	6	–	7.2	–	–	–	–	–	–	14
A-5555-2403	626105-1021-065	10	52.5	11	65.5	6	–	8	–	–	–	–	–	–	14
A-5555-2404	–	0.2	2.3/12.0	11	32	0.18/1.0	–	6.5	–	–	–	–	–	–	15
A-5555-2405	–	0.25	2.3/12.0	11	32	0.18/1.0	–	6.5	–	–	–	–	–	–	15
A-5555-2407	–	0.3	2.3/12.0	11	32	0.2/1.0	–	6.5	–	–	–	–	–	–	15
A-5555-2408	–	3	16.5	11	25.5	2	–	7	–	–	–	–	–	–	17
A-5555-2409	–	5	25.5	11	34.5	3.5	–	9	–	–	–	–	–	–	17
A-5555-2410	–	0.25	2.35	–	15.25	0.18/1.0	–	1	–	–	–	–	–	–	20
A-5555-2411	–	0.4	2.5	–	15.4	0.3/1.0	–	1	–	–	–	–	–	–	20
A-5555-2412	–	2	–	–	27	1	–	1	–	–	–	–	–	–	20
A-5555-2413	–	2.5	–	–	27.5	1	–	1	–	–	–	–	–	–	20
A-5555-2415	632001-8209-000	10	55	11	65	3.5/5.5	1	11	–	–	–	–	–	–	23
A-5555-2416	626115-1505-065	15	55	11	65	3.5/5.5	1	18	–	–	–	–	–	–	23
A-5555-2417	632001-8207-000	20	55	11	65	3.5/5.5	1	19	–	–	–	–	–	–	23
A-5555-2418	632001-8208-000	25	55	11	65	3.5/10.0	2	22	–	–	–	–	–	–	23
A-5555-2419	632001-8210-000	30	55	11	65	3.5/10.0	2	39	–	–	–	–	–	–	23
A-5555-2420	632001-8213-000	40	55	11	65	3.5/10.0	2	57	–	–	–	–	–	–	23
A-5555-2421	000000-1019-819	10	55	11	65	3.5/5.5	2	17	–	–	–	–	–	–	23
A-5555-2422	000000-1019-820	15	55	11	65	3.5/5.5	2	20	–	–	–	–	–	–	23
A-5555-2423	000000-1019-822	20	55	11	65	3.5/5.5	2	25	–	–	–	–	–	–	23
A-5555-2424	000000-1019-824	25	55	11	65	3.5/10.0	2	32	–	–	–	–	–	–	23
A-5555-2425	–	–	–	–	–	87.5	15	13	–	–	–	–	–	–	29
A-5555-2426	–	–	–	–	–	85	15	13.4	–	–	–	–	–	–	29
A-5555-2427	–	–	–	–	–	82.5	15	13.8	–	–	–	–	–	–	29
A-5555-2428	–	–	–	–	–	80	15	14.2	–	–	–	–	–	–	29
A-5555-2429	–	–	–	–	–	77.5	15	14.6	–	–	–	–	–	–	29
A-5555-2430	–	–	–	–	–	75	15	15	–	–	–	–	–	–	29

Codice Renishaw	Codice ZEISS	DK (mm)	ML1/ML (mm)	DG/D (mm)	L (mm)	DS1/DS (mm)	EAL/B (mm)	Peso (g)	A (mm)	Filettatura/ foro (mm)	Filettatura (da/a)	MB (mm)	G1 (mm)	SW (mm)	Pagina n.
A-5555-2431	–	–	–	–	–	72.5	15	15.4	–	–	–	–	–	–	29
A-5555-2432	–	–	–	–	–	70	15	15.8	–	–	–	–	–	–	29
A-5555-2433	–	–	–	–	–	67.5	15	16.2	–	–	–	–	–	–	29
A-5555-2434	–	–	–	–	–	65	15	16.6	–	–	–	–	–	–	29
A-5555-2435	–	–	–	–	–	62.5	15	17	–	–	–	–	–	–	29
A-5555-2436	–	–	–	–	–	60	15	17.4	–	–	–	–	–	–	29
A-5555-2437	–	–	–	–	–	57.5	15	17.8	–	–	–	–	–	–	29
A-5555-2438	–	–	–	–	–	55	15	18.2	–	–	–	–	–	–	29
A-5555-2439	–	–	–	–	–	52.5	15	18.6	–	–	–	–	–	–	29
A-5555-2440	–	–	–	–	–	50	15	19	–	–	–	–	–	–	29
A-5555-2441	–	–	–	–	–	47.5	15	19.4	–	–	–	–	–	–	29
A-5555-2442	–	–	–	–	–	45	15	19.8	–	–	–	–	–	–	29
A-5555-2443	–	–	–	–	–	–	–	–	–	–	–	–	–	–	37
A-5555-2444	–	5	25.5	11	34.5	3.5	–	9	–	–	–	–	–	–	18
A-5555-2445	626103-0311-030	3	21	5	30	2	–	0.75	–	–	–	–	–	–	45
A-5555-2446	–	0.2	2.3/9.0	4	22	0.18/1.0	–	1	–	–	–	–	–	–	55
A-5555-2447	–	0.25	2.3/9.0	4	22	0.18/1.0	–	1	–	–	–	–	–	–	55
A-5555-2448	–	2	34	4	40	1.5	–	1	–	–	–	–	–	–	55
A-5555-2449	–	4	22	4	30	2	–	2	–	–	–	–	–	–	56
A-5555-2450	–	5	22	4	30	2	–	2.1	–	–	–	–	–	–	56
A-5555-2451	–	5	32	4	40	2	–	2	–	–	–	–	–	–	56
A-5555-2452	–	5	42	4	50	2	–	3	–	–	–	–	–	–	56
A-5555-2453	–	5	52	4	60	2	–	3.5	–	–	–	–	–	–	56
A-5555-2454	–	6	22	4	30	2	–	2.3	–	–	–	–	–	–	56
A-5555-2455	–	8	18.5	4	31.5	2	–	1.3	–	–	–	–	–	–	56
A-5555-2456	–	–	–	4	30	1.5	–	2.9	–	–	–	–	–	–	58
A-5555-2457	000000-1049-178	–	–	4	7	–	–	0.5	–	–	M2/M3	–	–	–	59
A-5555-2458	000000-0015-247	–	–	–	–	–	3	–	–	–	–	–	–	–	60
A-5555-2459	000000-0015-248	–	–	–	–	–	4	–	–	–	–	–	–	–	60
A-5555-2460	–	–	–	–	–	–	5	–	–	–	–	–	–	–	60
A-5555-2461	–	–	–	–	–	–	10	–	–	–	–	–	–	–	60
A-5555-2462	–	0.25	2.3/12.5	3	17	0.18/1.0	–	0.4	–	–	–	–	–	–	61
A-5555-2463	–	1	5.0/14.0	3	18.5	0.8/1.0	–	0.4	–	–	–	–	–	–	61
A-5555-2465	–	2.5	6	3	12	1.5	–	1	–	–	–	–	–	–	61
A-5555-2466	–	3	6	3	12	2	–	1	–	–	–	–	–	–	61

Codice Renishaw	Codice ZEISS	DK (mm)	ML1/ML (mm)	DG/D (mm)	L (mm)	DS1/DS (mm)	EAL/B (mm)	Peso (g)	A (mm)	Filettatura/ foro (mm)	Filettatura (da/a)	MB (mm)	G1 (mm)	SW (mm)	Pagina n.
A-5555-2467	–	4	12	3	16	2	–	0.8	–	–	–	–	–	–	62
A-5555-2468	–	4	30	3	36	2	–	1	–	–	–	–	–	–	62
A-5555-2469	–	5	10	3	14	2	–	0.8	–	–	–	–	–	–	62
A-5555-2470	–	5	32	3	38	2	–	1	–	–	–	–	–	–	62
A-5555-2471	–	4	32	3	32	3	–	1.7	–	–	–	–	–	–	63
A-5555-2472	–	4	42	3	42	3	–	2.4	–	–	–	–	–	–	63
A-5555-2473	–	4	52	3	52	3	–	2.9	–	–	–	–	–	–	63
A-5555-2474	–	5	22	3	22	3	–	1.3	–	–	–	–	–	–	63
A-5555-2475	–	5	32	3	32	3	–	1.9	–	–	–	–	–	–	63
A-5555-2476	–	5	42.5	3	42.5	3	–	2.5	–	–	–	–	–	–	63
A-5555-2477	–	5	52.5	3	52.5	3	–	3.1	–	–	–	–	–	–	63
A-5555-2478	–	–	–	3	30	1	–	2.9	–	–	–	–	–	–	67
A-5555-2479	–	–	–	3	30	1.5	–	2.9	–	–	–	–	–	–	67
A-5555-2481	–	–	–	3	50	–	–	2.7	–	–	–	–	–	–	66
A-5555-3734	626115-0300-058	3	48	11	58	2	–	5.5	–	–	–	–	–	–	10
A-5555-3740	–	–	191.5	11	150	–	15	77	–	–	–	–	–	–	40
A-5555-3777	–	1	5.0/10.0	11	20	0.8/1.0	–	3.5	–	–	–	–	–	–	10
A-5555-3778	–	1	5.0/15.0	11	25	0.8/1.0	–	3.5	–	–	–	–	–	–	10
A-5555-3779	–	1	5.0/20.0	11	30	0.8/1.0	–	3.5	–	–	–	–	–	–	10
A-5555-3780	–	1.5	8.0/20.0	11	30	1.0/1.5	–	3.5	–	–	–	–	–	–	10
A-5555-3781	–	2	10	11	20	1	–	3.5	–	–	–	–	–	–	10
A-5555-3782	–	2	15	11	25	1	–	3.5	–	–	–	–	–	–	10
A-5555-3783	–	2	20	11	30	1.5	–	3.8	–	–	–	–	–	–	10
A-5555-3784	–	2	30	11	40	1.5	–	4	–	–	–	–	–	–	10
A-5555-3785	626115-0303-025	3	15	11	25	2	–	4	–	–	–	–	–	–	10
A-5555-3786	–	3	23.5	11	33.5	2	–	4.5	–	–	–	–	–	–	10
A-5555-3787	626115-0302-050	3	40	11	50	2	–	5.3	–	–	–	–	–	–	10
A-5555-3788	626115-0400-034	4	23.5	11	33.5	2	–	4.5	–	–	–	–	–	–	10
A-5555-3789	–	4	54	11	64	2	–	5.9	–	–	–	–	–	–	10
A-5555-3790	–	5	20	11	30	3.5	–	8	–	–	–	–	–	–	10
A-5555-3791	626115-0501-050	5	40	11	50	3.5	–	9	–	–	–	–	–	–	10
A-5555-3792	–	5	43	11	53	3.5	–	9.8	–	–	–	–	–	–	10
A-5555-3793	626115-0500-075	5	65	11	75	3.5	–	12.5	–	–	–	–	–	–	10
A-5555-3794	626115-0501-100	5	90	11	100	3.5	–	18	–	–	–	–	–	–	10
A-5555-3795	–	6	44	11	54	3.5	–	10	–	–	–	–	–	–	10

Codice Renishaw	Codice ZEISS	DK (mm)	ML1/ML (mm)	DG/D (mm)	L (mm)	DS1/DS (mm)	EAL/B (mm)	Peso (g)	A (mm)	Filettatura/ foro (mm)	Filettatura (da/a)	MB (mm)	G1 (mm)	SW (mm)	Pagina n.
A-5555-3796	–	7	45	11	55	3.5	–	10	–	–	–	–	–	–	10
A-5555-3797	626115-0800-064	8	50.5	11	63.5	6	–	36.6	–	–	–	–	–	–	10
A-5555-3798	626115-0800-075	8	62	11	75	6	–	29.4	–	–	–	–	–	–	10
A-5555-3799	–	8	87	11	100	6	–	39.9	–	–	–	–	–	–	11
A-5555-3800	626115-0800-115	8	101.5	11	114.5	6	–	45.7	–	–	–	–	–	–	11
A-5555-3801	–	9	51.5	11	64.5	6	–	26.3	–	–	–	–	–	–	11
A-5555-3802	–	10	52.5	11	65.5	6	–	25.8	–	–	–	–	–	–	11
A-5555-3803	–	10	105	11	118	6	–	47.3	–	–	–	–	–	–	11
A-5555-3804	–	10	135	11	150	6	–	60	–	–	–	–	–	–	11
A-5555-3805	600342-8023-010	8	50.5	11	63.5	6	–	24.8	–	–	–	–	–	–	11
A-5555-3806	626105-0300-058	3	48	11	58	2	–	4.9	–	–	–	–	–	–	12
A-5555-3807	626105-0820-063	8	50.5	11	63.5	6	–	7	–	–	–	–	–	–	12
A-5555-3808	626105-0820-114	8	101.5	11	114.5	6	–	9.5	–	–	–	–	–	–	12
A-5555-3809	–	9	51.5	11	64.5	6	–	7.2	–	–	–	–	–	–	12
A-5555-3812	626105-0301-025	3	15	11	25	2	–	4	–	–	–	–	–	–	13
A-5555-3813	626105-0301-050	3	40	11	50	2	–	4.5	–	–	–	–	–	–	13
A-5555-3814	626105-0301-058	3	48	11	58	2	–	4.9	–	–	–	–	–	–	13
A-5555-3815	626105-0301-033	4	23.5	11	33.5	2	–	4.2	–	–	–	–	–	–	13
A-5555-3817	626105-0511-050	5	40	11	50	3.5	–	4.8	–	–	–	–	–	–	13
A-5555-3820	626105-0821-100	8	87	11	100	6	–	7.5	–	–	–	–	–	–	13
A-5555-3821	626105-0821-114	8	101.5	11	114.5	6	–	9.5	–	–	–	–	–	–	13
A-5555-3824	626105-1021-118	10	105	11	118	6	–	14.5	–	–	–	–	–	–	14
A-5555-3825	626105-1021-150	10	137	11	150	6	–	16	–	–	–	–	–	–	14
A-5555-3826	–	2	24.5	11	33.5	1	–	7	–	–	–	–	–	–	18
A-5555-3827	–	2.5	25	11	34	1	–	7	–	–	–	–	–	–	18
A-5555-3828	–	3	16.5	11	25.5	2	–	9	–	–	–	–	–	–	18
A-5555-3839	–	1	30	11	40	0.8/4.0	–	9	8	–	–	–	–	–	25
A-5555-3841	–	–	–	18	58	–	–	58	–	–	–	–	–	–	27
A-5555-3842	–	15	–	24	130	–	–	–	–	–	–	–	–	22	36
A-5555-3843	–	20	–	24	135	–	–	–	–	–	–	–	–	22	36
A-5555-3844	–	25	–	24	140	–	–	–	–	–	–	–	–	22	36
A-5555-3845	–	–	66.5	11	25	–	15	60	–	–	–	–	–	–	40
A-5555-3846	–	–	81.5	11	40	–	15	62	–	–	–	–	–	–	40
A-5555-3847	–	–	91.5	11	50	–	15	64	–	–	–	–	–	–	40
A-5555-3848	–	–	101.5	11	60	–	15	66	–	–	–	–	–	–	40

Codice Renishaw	Codice ZEISS	DK (mm)	ML1/ML (mm)	DG/D (mm)	L (mm)	DS1/DS (mm)	EAL/B (mm)	Peso (g)	A (mm)	Filettatura/ foro (mm)	Filettatura (da/a)	MB (mm)	G1 (mm)	SW (mm)	Pagina n.
A-5555-3849	–	–	121.5	11	80	–	15	68	–	–	–	–	–	–	40
A-5555-3850	–	–	141.5	11	100	–	15	70	–	–	–	–	–	–	40
A-5555-3851	–	–	161.5	11	120	–	15	72	–	–	–	–	–	–	40
A-5555-3852	–	–	241.5	11	200	–	15	84	–	–	–	–	–	–	40
A-5555-3853	626113-0060-014	0.6	4.6/5.0	5	14	0.4/1.0	–	0.61	–	–	–	–	–	–	41
A-5555-3854	626113-0101-020	1	5.1/11	5	20	0.6/1.0	–	0.7	–	–	–	–	–	–	41
A-5555-3855	626113-0201-040	2	31	5	40	1.5	–	1.7	–	–	–	–	–	–	42
A-5555-3856	626113-0250-020	2.5	11	5	20	1.5	–	1	–	–	–	–	–	–	42
A-5555-3857	626113-0250-030	2.5	21	5	30	1.5	–	1.5	–	–	–	–	–	–	42
A-5555-3858	626103-0501-050	5	41	5	50	3.5	–	1.4	–	–	–	–	–	–	42
A-5555-3859	626103-0300-025	3	16	5	25	2	–	0.65	–	–	–	–	–	–	43
A-5555-3860	626103-0300-058	3	49	5	58	2	–	1	–	–	–	–	–	–	43
A-5555-3861	626103-0300-059	3	50	5	59	2	–	1	–	–	–	–	–	–	43
A-5555-3862	626103-0300-075	3	66	5	75	2	–	1	–	–	–	–	–	–	43
A-5555-3863	626103-0500-040	5	31	5	40	3.5	–	1.2	–	–	–	–	–	–	43
A-5555-3864	626103-0500-060	5	51	5	60	3.5	–	1.5	–	–	–	–	–	–	43
A-5555-3865	626103-0610-070	6	61	5	70	3.5	–	1.8	–	–	–	–	–	–	43
A-5555-3866	626103-0800-030	8	30	5	30	5	–	1.86	–	–	–	–	–	–	43
A-5555-3867	626103-0830-050	8	50	5	50	5	–	2.1	–	–	–	–	–	–	43
A-5555-3868	626103-0830-070	8	70	5	70	5	–	2.6	–	–	–	–	–	–	43
A-5555-3869	626103-0830-100	8	100	5	100	5	–	2.7	–	–	–	–	–	–	43
A-5555-3870	626103-0301-033	3	24	5	33	2	–	0.7	–	–	–	–	–	–	44
A-5555-3871	626103-0301-050	3	41	5	50	2	–	0.8	–	–	–	–	–	–	44
A-5555-3872	626103-0502-050	5	41	5	50	3.5	–	1.4	–	–	–	–	–	–	44
A-5555-3874	626103-0801-125	8	125	5	125	5	–	2.9	–	–	–	–	–	–	44
A-5555-3875	626103-0301-020	3	11	5	20	2	–	0.7	–	–	–	–	–	–	44
A-5555-3876	626103-0301-030	3	21	5	30	2	–	0.75	–	–	–	–	–	–	44
A-5555-3877	626103-0311-020	3	11	5	20	2	–	0.7	–	–	–	–	–	–	45
A-5555-3880	626103-0312-020	3	11	5	20	2	–	0.8	–	–	–	–	–	–	46
A-5555-3881	626103-0312-030	3	21	5	30	2	–	0.9	–	–	–	–	–	–	46
A-5555-3882	626103-0303-020	3	11	5	20	2	–	1.4	–	–	–	–	–	–	46
A-5555-3883	626103-0303-030	3	21	5	30	2	–	1.5	–	–	–	–	–	–	46
A-5555-3884	626103-0313-020	3	11	5	20	2	–	1.4	–	–	–	–	–	–	47
A-5555-3885	626103-0313-030	3	21	5	30	2	–	1.5	–	–	–	–	–	–	47
A-5555-3886	626103-0313-040	3	31	5	40	2	–	1.6	–	–	–	–	–	–	47

Codice Renishaw	Codice ZEISS	DK (mm)	ML1/ML (mm)	DG/D (mm)	L (mm)	DS1/DS (mm)	EAL/B (mm)	Peso (g)	A (mm)	Filettatura/ foro (mm)	Filettatura (da/a)	MB (mm)	G1 (mm)	SW (mm)	Pagina n.
A-5555-3887	626103-0304-020	3	11	5	20	2	–	1.4	–	–	–	–	–	–	47
A-5555-3888	626103-0304-030	3	21	5	30	2	–	1.5	–	–	–	–	–	–	47
A-5555-3889	626103-0314-020	3	11	5	20	2	–	1.4	–	–	–	–	–	–	48
A-5555-3890	626103-0314-030	3	21	5	30	2	–	1.5	–	–	–	–	–	–	48
A-5555-3891	626103-0314-040	3	31	5	40	2	–	1.6	–	–	–	–	–	–	48
A-5555-3892	626103-5020-000	–	–	5	20	–	–	1.2	–	–	–	–	–	–	48
A-5555-3893	626103-5040-000	–	–	5	40	–	–	1.4	–	–	–	–	–	–	48
A-5555-3894	626103-5060-000	–	–	5	60	–	–	1.7	–	–	–	–	–	–	48
A-5555-3895	626103-5130-000	–	–	5	130	–	–	2.5	–	–	–	–	–	–	48
A-5555-3896	626103-6110-002	–	–	–	13	–	5	1.05	–	–	–	–	–	–	52
A-5555-3898	626103-6110-006	–	–	12	–	–	5	1.79	–	–	–	–	–	–	53
A-5555-3899	626103-6110-007	–	–	14	–	–	5	2.31	–	–	–	–	–	–	53
A-5555-3900	–	–	–	–	–	–	–	72	–	–	–	–	–	–	39
A-5555-3901	626103-0312-040	3	31	5	40	2	–	1	–	–	–	–	–	–	46
A-5555-3949	000000-1073-344	5	95	11	105	3.5	–	15	–	–	–	–	–	–	9
A-5555-3997	626105-0820-075	8	62	11	75	6	–	7.3	–	–	–	–	–	–	12
A-5555-3998	626105-1020-118	10	105	11	118	6	–	14.5	–	–	–	–	–	–	13
A-5555-3999	–	0.5	3.5	11	40	0.4	1.9	7	–	–	–	–	–	–	24
A-5555-9159	–	0.3	2.3/13.5	3	18	0.2/1.0	–	0.4	–	–	–	–	–	–	61
A-5555-9161	–	0.6	4.6/13.8	3	18.3	0.4/1.0	–	0.4	–	–	–	–	–	–	61
A-5555-9162	–	0.8	4.8/13.5	3	18.0	0.6/1.0	–	0.4	–	–	–	–	–	–	61
A-5555-9325	626115-0200-034	2	24.5	11	33.5	1.5	–	7	–	–	–	–	–	–	18
A-5555-9339	626113-0151-030	1.5	21	5	30	1	–	0.84	–	–	–	–	–	–	42
A-5555-9340	626113-0150-030	1.5	22.5	5	30	1	–	0.9	–	–	–	–	–	–	42
A-5555-9341	626113-0100-040	1	5.0/31	5	40	0.8/1.0	–	1.5	–	–	–	–	–	–	41
A-5555-9361	626105-0820-150	8	137	11	150	6	–	11	–	–	–	–	–	–	12

www.renishaw.it/contatto

 #renishaw

 +39 011 9666700

 italy@renishaw.com

© 2004-2024 Renishaw plc. Tutti i diritti riservati. Questo documento non può essere copiato o riprodotto nella sua interezza o in parte, né trasferito su altri supporti o tradotto in altre lingue, senza previa autorizzazione scritta da parte di Renishaw. RENISHAW™ e il simbolo della sonda sono marchi registrati di Renishaw plc. I nomi dei prodotti Renishaw, le denominazioni e il marchio "apply innovation" sono marchi di Renishaw plc o delle sue società controllate. Altri nomi di marchi, prodotti o società sono marchi dei rispettivi proprietari.
Renishaw plc. Registrata in Inghilterra e Galles. Numero di registro dell'azienda: 1106260. Sede legale: New Mills, Wotton-under-Edge, Glos, GL12 8JR, Regno Unito.

SEBBENE SIANO STATI COMPIUTI SFORZI NOTEVOLI PER VERIFICARE L'ACCURATEZZA DEL PRESENTE DOCUMENTO AL MOMENTO DELLA PUBBLICAZIONE, TUTTE LE GARANZIE, LE CONDIZIONI, LE DESCRIZIONI E LE RESPONSABILITÀ, COMUNQUE DERIVANTI, SONO ESCLUSE NELLA MISURA CONSENTITA DALLA LEGGE. RENISHAW SI RISERVA IL DIRITTO DI APPORTARE MODIFICHE AL DOCUMENTO, ALLE APPARECCHIATURE E/O AL SOFTWARE E ALLE SPECIFICHE QUI RIPORTATE SENZA INCORRERE IN ALCUN OBBLIGO DI NOTIFICA.

Codice: H-1000-3097-06-C
Pubblicato: 06.2024