

RVP user's guide

www.renishaw.com

# RVP user's guide

Document part number: H-1000-3322-07-B



## RVP user's guide

www.renishaw.com

# RVP general information

© 2015 - 2024 Renishaw plc. All rights reserved.

 ORIGINAL LANGUAGE VERSION

This document may not be copied or reproduced in whole or in part, or transferred to any other media or language by any means, without the prior written permission of Renishaw.

## Disclaimer

WHILE CONSIDERABLE EFFORT WAS MADE TO VERIFY THE ACCURACY OF THIS DOCUMENT AT PUBLICATION, ALL WARRANTIES, CONDITIONS, REPRESENTATIONS AND LIABILITY, HOWSOEVER ARISING, ARE EXCLUDED TO THE EXTENT PERMITTED BY LAW.

RENISHAW RESERVES THE RIGHT TO MAKE CHANGES TO THIS DOCUMENT AND TO THE EQUIPMENT, AND/OR SOFTWARE AND THE SPECIFICATION DESCRIBED HEREIN WITHOUT OBLIGATION TO PROVIDE NOTICE OF SUCH CHANGES.

## Trade marks

RENISHAW<sup>®</sup>, the probe symbol and REVO<sup>®</sup> are registered trade marks of Renishaw plc.

Renishaw product names, designations and the mark 'apply innovation' are trade marks of Renishaw plc or its subsidiaries.

Other brand, product or company names are trade marks of their respective owners.

## WEEE



The use of this symbol on Renishaw products and / or accompanying documentation indicates that the product should not be mixed with general household waste upon disposal. It is the responsibility of the end user to dispose of this product at a designated collection point for waste electrical and electronic equipment (WEEE) to enable reuse or recycling. Correct disposal of this product will help to save valuable resources and prevent potential negative effects on the environment. For more information, please contact your local waste disposal service or Renishaw distributor.

## RVP user's guide

[www.renishaw.com](http://www.renishaw.com)

## Software notices

The RVP product includes embedded software to which the following notices apply:

### EULA

The software is subject to the terms and conditions of the software licence agreement at [www.renishaw.com/legal/softwareterms](http://www.renishaw.com/legal/softwareterms).

### Third party licences

Third party licence information can be found in the following UCCsuite installation directory:

...\Renishaw\UCC\Utilities\UCCassist Mark II\Firmware\RVP\Licences

In a typical installation the location address will be:

C:\Program Files (x86)\Renishaw\UCC\Utilities\UCCassist Mark II\Firmware\RVP\Licences

## Notice to United States Government Contract and Prime Contract Customers

This software is commercial computer software that has been developed by Renishaw exclusively at private expense. Notwithstanding any other lease or licence agreement that may pertain to, or accompany the delivery of, this computer software, the rights of the United States Government and/or its prime contractors regarding its use, reproduction and disclosure are as set forth in the terms of the contract or subcontract between Renishaw and the United States Government, civilian federal agency or prime contractor respectively. Please consult the applicable contract or subcontract and the software licence incorporated therein, if applicable, to determine your exact rights regarding use, reproduction and/or disclosure.

## RVP user's guide

[www.renishaw.com](http://www.renishaw.com)

### Warranty

Unless you and Renishaw have agreed and signed a separate written agreement, the equipment and/or software are sold subject to the Renishaw Standard Terms and Conditions supplied with such equipment and/or software, or available on request from your local Renishaw office.

Renishaw warrants its equipment and software for a limited period (as set out in the Standard Terms and Conditions), provided that they are installed and used exactly as defined in associated Renishaw documentation. You should consult these Standard Terms and Conditions to find out the full details of your warranty.

Equipment and/or software purchased by you from a third-party supplier is subject to separate terms and conditions supplied with such equipment and/or software. You should contact your third-party supplier for details.

### Care of equipment

Renishaw probes and associated systems are precision tools used for obtaining precise measurements and must therefore be treated with care.

### Changes to Renishaw products

Renishaw reserves the right to improve, change or modify its hardware or software without incurring any obligations to make changes to Renishaw equipment previously sold.

### Company registration details

Renishaw plc. Registered in England and Wales. Company no: 1106260. Registered office: New Mills, Wotton-under-Edge, Gloucestershire, GL12 8JR, UK.

## RVP user's guide

www.renishaw.com

### Packaging

To aid end user recycling and disposal the materials used in the different components of the packaging are stated here:

Packaging component	Material	94/62/EC code	94/62/EC number
Outer box	Non-corrugated fibreboard	PAP	21
Storage box	Polypropylene	PP	05
Packing foam	Low density polyethylene	LDPE	04
Packaging insert	Corrugated fibreboard	PAP	20
Stylus box	Polypropylene	PP	05
Stylus box label	Polypropylene	PP	05
Bag	Low density polyethylene	LDPE	04



**CAUTION:** If it is necessary to return any part of the system please ensure it is packaged carefully. Failure to do so could result in transit damage for which the customer would be liable. Products supplied in plastic boxes must be returned in the original packaging.

### Patents

Features of Renishaw's RVP and associated products (such as REVO-2) are the subjects of one or more of the following patents and patent applications:

CN101166951	EP1877727	IN405412	JP5196356	US10260856
CN101166953	EP1877732	IN446044	JP5350216	US10591289
CN101405563	EP1989504		JP5425476	US10627259
CN101405564	EP2002206		JP5653581	US11402201
CN101490430	EP2002207		JP5658863	US7533574
CN101772690	EP2035719		JP5706158	US7809523
CN102305613	EP2140318		JP5851969	US7861430
CN102906533	EP2167911		JP6013533	US7885777
CN103842766	EP2431707		JP6199870	US8006398
CN105408723	EP2564151		JP6348577	US8186882
CN105793695	EP2764324		JP7042620	US8302321
CN107532930	EP3004797		JP7105769	US8425119
CN109964098	EP3052926		JP7246127	US8474148
CN201680041034.2	EP3289314		JP7353757	US8511898
	EP3322959			US8601701
	EP3542130			US8756973
				US8978261
				US9038282
				US9366519
				US9903713

## RVP user's guide

[www.renishaw.com](http://www.renishaw.com)

# RVP product compliance

## EU declaration of conformity

Contact Renishaw plc or visit [www.renishaw.com/EUCMM](http://www.renishaw.com/EUCMM) for the full EU declaration.

---

## UK declaration of conformity

Contact Renishaw plc or visit [www.renishaw.com/UKCMM](http://www.renishaw.com/UKCMM) for the full UK declaration.

---

## EMC conformity

This equipment must be installed and used in accordance with this installation guide. This product is intended for industrial use only and should not be used in a residential area or connected to a low voltage power supply network which supplies buildings used for residential purposes.

---

## FCC (USA only)

### Information to user (47 CFR 15.105)

This equipment has been tested and found to comply with the limits for a Class A digital device, pursuant to Part 15 of the FCC rules. These limits are designed to provide reasonable protection against harmful interference when the equipment is operated in a commercial environment. This equipment generates, uses, and can radiate radio frequency energy and, if not installed and used in accordance with the instruction manual, may cause harmful interference to radio communications. Operation of this equipment in a residential area is likely to cause harmful interference, in which case you will be required to correct the interference at your own expense.

### Information to user (47 CFR 15.21)

The user is cautioned that any changes or modifications not expressly approved by Renishaw plc or authorised representative could void the user's authority to operate the equipment.

### Equipment label (47 CFR 15.19)

This device complies with part 15 of the FCC Rules. Operation is subject to the following two conditions:

1. This device may not cause harmful interference.
  2. This device must accept any interference received, including interference that may cause undesired operation.
-

## RVP user's guide

[www.renishaw.com](http://www.renishaw.com)

### ICES-001 (Canada only)

This ISM device complies with Canadian ICES-001(A) / NMB-001(A).

Cet appareil ISM est conforme à la norme ICES-001(A) / NMB-001(A) du Canada.

---

### REACH regulation

Information required by Article 33(1) of Regulation (EC) No. 1907/2006 ("REACH") relating to products containing substances of very high concern (SVHCs) is available at:

[www.renishaw.com/REACH](http://www.renishaw.com/REACH)

---

### China RoHS

Contact Renishaw plc or visit [www.renishaw.com/ChinaRoHSCMM](http://www.renishaw.com/ChinaRoHSCMM) for the full China RoHS tabulation.



## RVP user's guide

www.renishaw.com

# RVP safety

Before unpacking and installing the RVP system, the user should carefully read the safety instructions below and ensure that they are followed at all times by all operators.

The RVP vision probe system should only be used with the REVO-2 head.

Operators must be trained in the use and application of the REVO-2 system and accompanying products, in the context of the machine it is fitted to, before being allowed to operate that machine.

Permanent magnets are used in some components of the REVO-2 system and associated products. It is important to keep them away from items which may be affected by magnetic fields, e.g. data storage systems, pacemakers and watches.



**WARNING:** Avoid touching the probe (including counter balance arms), modules, and ACM when attached to the REVO-2 head, especially when it is engaged (servo LED green) and the system is ready for measurement. If contact is made with the hardware, the tool will need to be reconfigured before continuing.

## VM10, VM11-2 and VM12 LED emissions

The vision modules incorporate high power LED lights and should not be used in the event of serious damage to any part of the VM10, VM11-2 or VM12 modules. In such cases immediately disconnect the power source, remove and do not attempt to reuse the parts. Contact your supplier for advice.



**CAUTION:** This equipment uses LED illumination that may flash at a variable rate. Avoid exposure or seek advice from your medical practitioner if you are susceptible to photosensitivity or related health effects.



# RVP environmental and electrical specifications

## Environmental specification

Ambient operating temperature range	+10 °C to +40 °C
Storage temperature range	-25 °C to +70 °C (-13 °F to 158 °F)
Operating humidity	0% to 80% (non-condensing)
Storage humidity	0% to 80% (non-condensing)

## Electrical specification

The REVO-2 head and probe electronics are powered from the UCC S5. The head motors are powered from the SPA3. The VPCP and VMCP are powered by a separate power supply that is supplied by Renishaw. Any additional backlighting is powered by a separate power supply that is supplied by Renishaw. No additional power supplies are required.

## RVP user's guide

[www.renishaw.com](http://www.renishaw.com)

# RVP references and associated documents

The following Renishaw documents are referred to in this document or may be a source of further relevant information. They can easily be acquired from Renishaw website [www.renishaw.com](http://www.renishaw.com).

User guide: REVO-2 (H-1000-7590)  
Installation & user's guide: RSP3 (H-1000-5124)  
Installation & user's guide: SFP2 (H-1000-5365)  
User guide: RVP (H-1000-3322)  
User guide: RFP1 (H-1000-5430)  
Installation & user's guide: RUP1 (H-1000-5396)  
Installation & user's guide: RTP1 (H-1000-5406)  
Installation guide: UCC S5 REVO-2 CMM controller (H-1000-7598)  
Installation guide: SPA3-2 (H-1000-5364)  
Installation & user's guide: MCULite-2, MCU5-2 and MCU W-2 (H-1000-5280)  
Installation & user's guide: MRS (H-1000-5088)  
Installation guide: MRS2 (H-1000-5255)  
Installation guide: REVO-2 change system port spacing guide ( H-1000-5408)  
Technical specifications: Styli and accessories (H-1000-3200)

# RVP system description

RVP is a non-contact vision measurement probe for use with the REVO-2 5-axis measurement system on co-ordinate measuring machines. RVP increases the multi-sensor capability of REVO-2 by adding non-contact inspection to the existing touch-trigger, high-speed tactile scanning and surface finish capability of the system.

The RVP system comprises a probe and a range of modules that are automatically interchangeable with all other probe options available for REVO. This flexibility means that the optimum tool can be selected to inspect a wide range of features, all on one CMM platform.

The RVP system is managed by the same I++ DME compliant interface as REVO-2 and full user functionality is provided by Renishaw's MODUS metrology software. New MODUS vision software capability includes RVP configuration, image processing with application specific options and automatic image storage for review and further analysis.

# Design principles of the RVP system

The RVP system uses an industry standard CMOS image sensor to capture and then detect the position of features using the contrast between light and dark areas of the image. Data points are projected on to the location where the image contrast changes from light to dark. A detailed calibration model of the lens system transforms the co-ordinates of the projected point on the image to real-world, three dimensional co-ordinates on the part.

# System components overview



## RVP user's guide

www.renishaw.com

Key	Description	Part number
1	REVO-2 head	A-5759-0001
2	RVP vision probe	A-5378-0080
3	VM10 vision module	A-5378-0082
4	VM11-2 vision module	A-5378-0093
5	VM12 vision module	A-5378-0088
6	VPCP probe change port	A-5378-0081
7	VMCP module change port	A-5378-0083
8	VA90 calibration adaptor	A-5378-0091
9	ACM kit	A-5378-0094
10	VA11 calibration artefact	A-5378-0089



**\* NOTE:** VA90 calibration adaptor shown fitted to VA11. The VA90 calibration adaptor (A-5378-0091) does not include the VA11.

## RVP probe

RVP is the probe component of the system that houses the sensor and digital signal processor. There are currently two vision modules that attach to the probe body that enable the inspection of a range of size and shape features.

The RVP component of the system is automatically interchangeable with other probe options using the VPCP heated change port that can be fixed to the MRS rack system.

## RVP user's guide

www.renishaw.com

### Vision modules

The RVP system features three interchangeable vision modules (VM10, VM11-2 and VM12) which are tailored to provide inspection capability for different applications. The vision modules attach to the probe body using the same style kinematic mount utilised by all the current REVO probes.



VM10 has a wider field of view allowing larger features to be inspected. VM11-2 has a greater stand-off distance which improves accessibility when inspecting complex parts with hard to reach features. VM12 has high magnification for inspection of very small features.

### ACM accessory

The ACM is an accessory designed to enhance access for the RVP non-contact vision system. Using a precision, first-surface mirror, ACM rotates the field of view through 90° allowing vision inspection of bore surfaces and other features previously inaccessible to RVP. ACM is compatible with VM11-2, attaching magnetically to a kinematic ring on the module.



**NOTE:** ACM uses a first-surface mirror - the reflective coating is on the front surface of the glass and is very delicate. Care must be taken to avoid touching the mirror surface to prevent contamination and damage.

## RVP user's guide

[www.renishaw.com](http://www.renishaw.com)

### VA11 calibration artefact and VA90 calibration adaptor

The VA11 is a dedicated calibration artefact used to calibrate the target feature size and stand-off distance of the RVP system when using a VM10, VM11-2 or VM12. The VA90 calibration adaptor converts VA11 into a calibration artefact compatible with ACM. The calibration routine for RVP is fully automated through MODUS and UCCsuite.

### VPCP and VMCP change ports

There are two new change ports that can be mounted to an MRS rack system to allow the automated changing of all the RVP probe and module components.

The VPCP change port is used to change and house the RVP probe body on the machines rack system. The VMCP change port changes and houses the ACM and vision module components of the RVP system. Both rack ports are temperature controlled to ensure that the housed components are at the correct and most efficient operating temperature.



RVP user's guide

www.renishaw.com

# RVP dimensional information

## RVP REVO vision probe

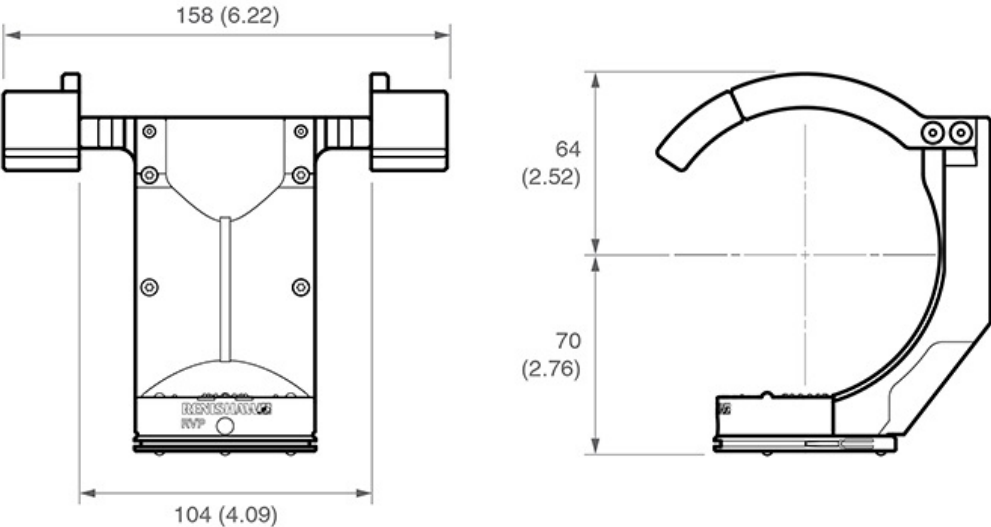

## Vision modules

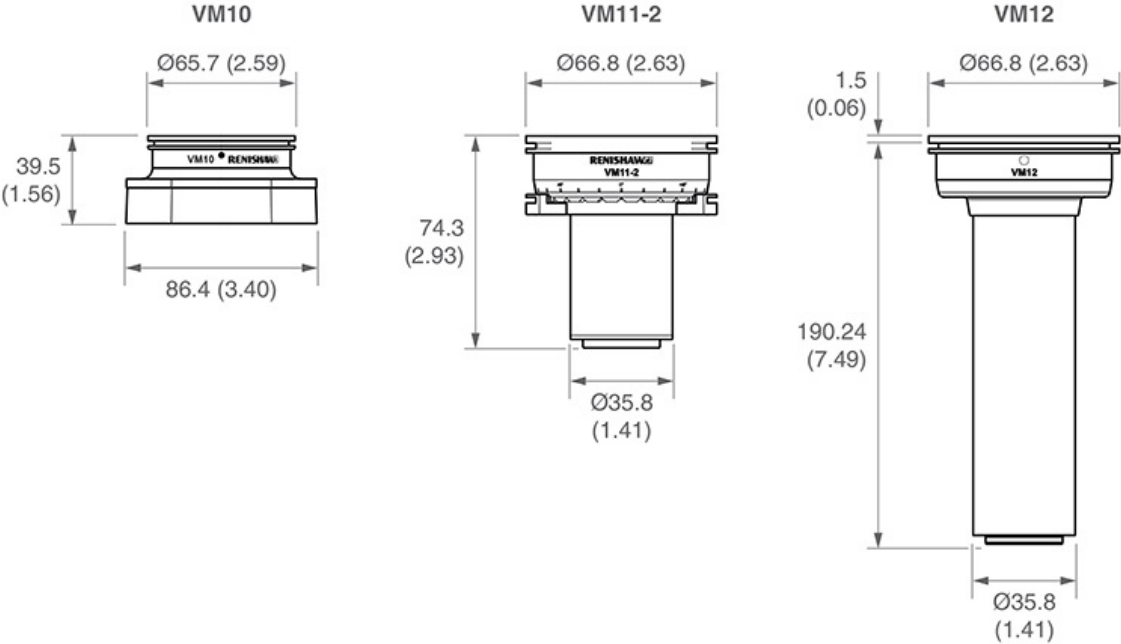

# RVP user's guide

www.renishaw.com

## Angle change mirror

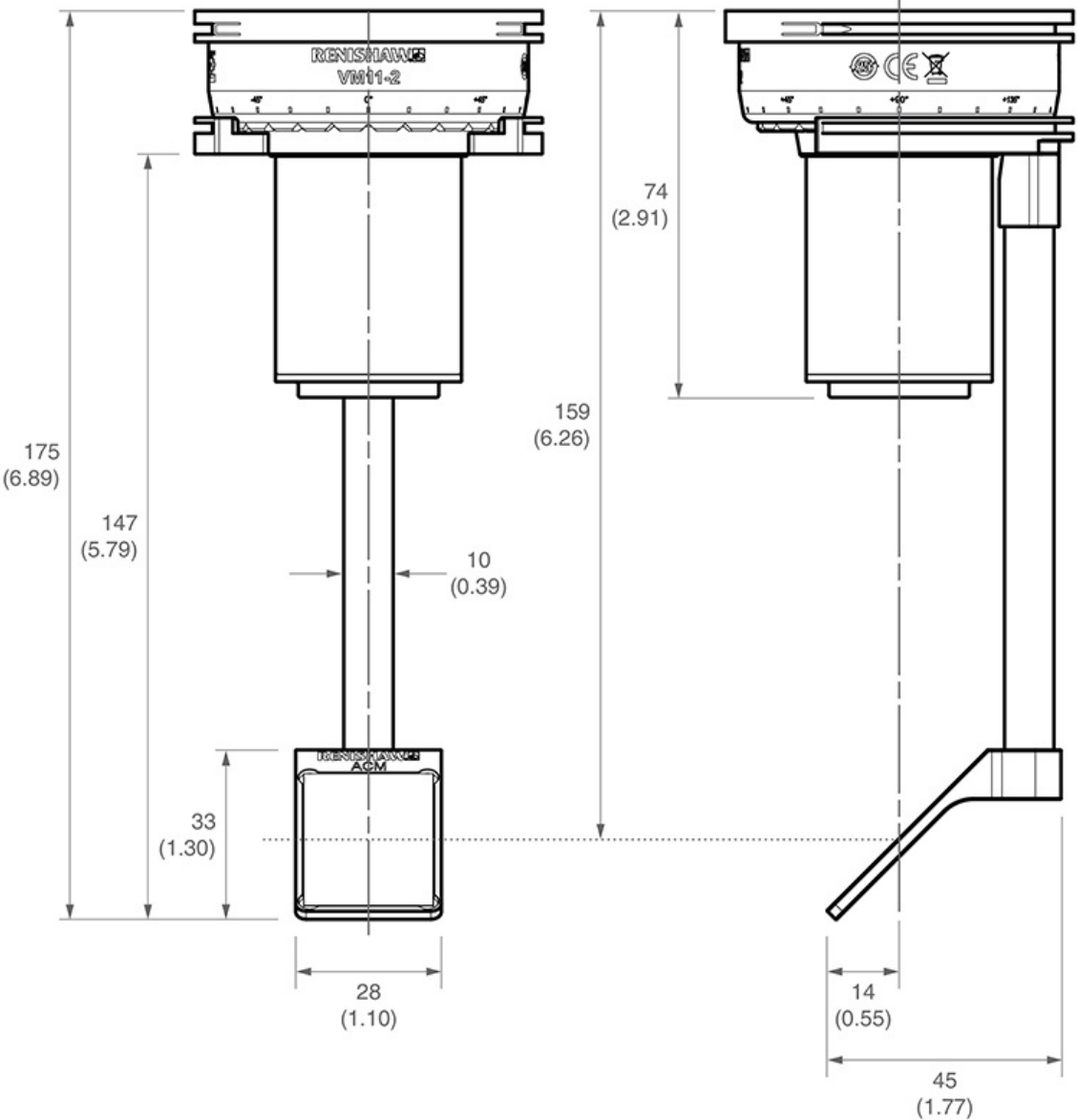

# RVP user's guide

www.renishaw.com

## Change ports

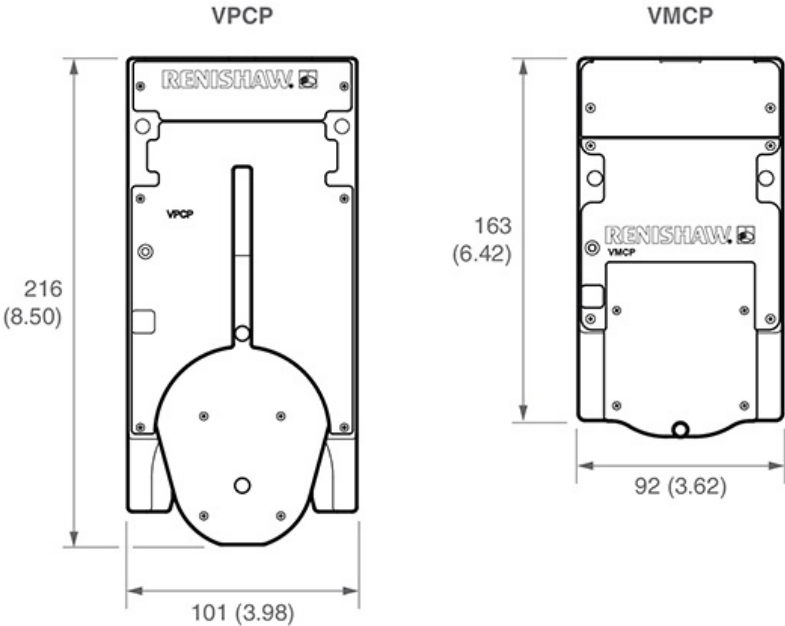

## VA11 calibration artefact

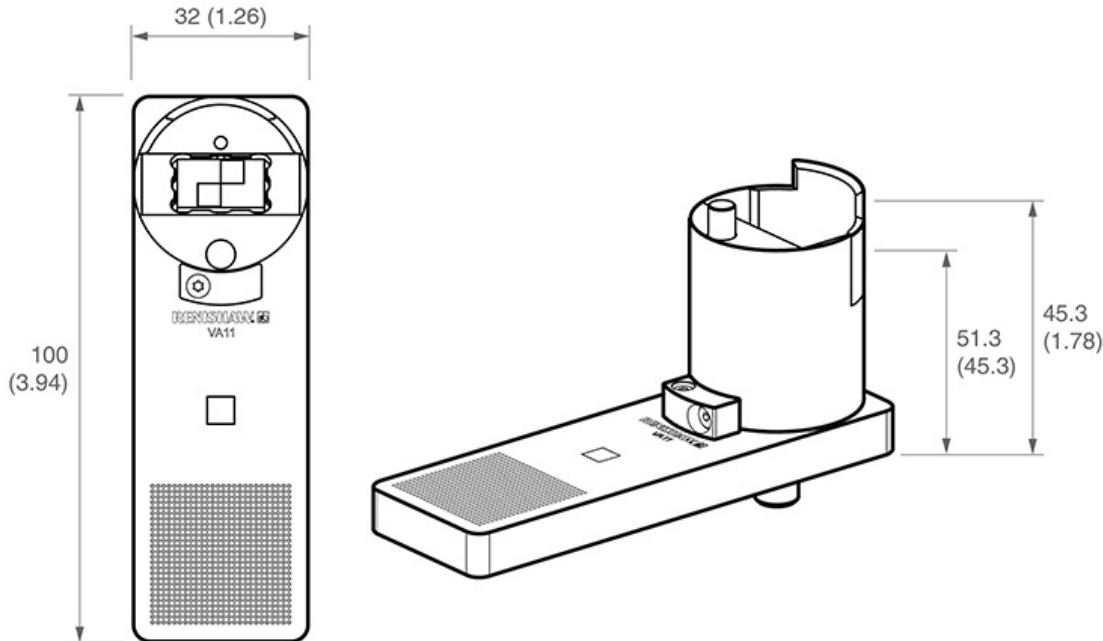

# RVP user's guide

www.renishaw.com

## VA90 calibration adaptor fitted to VA11

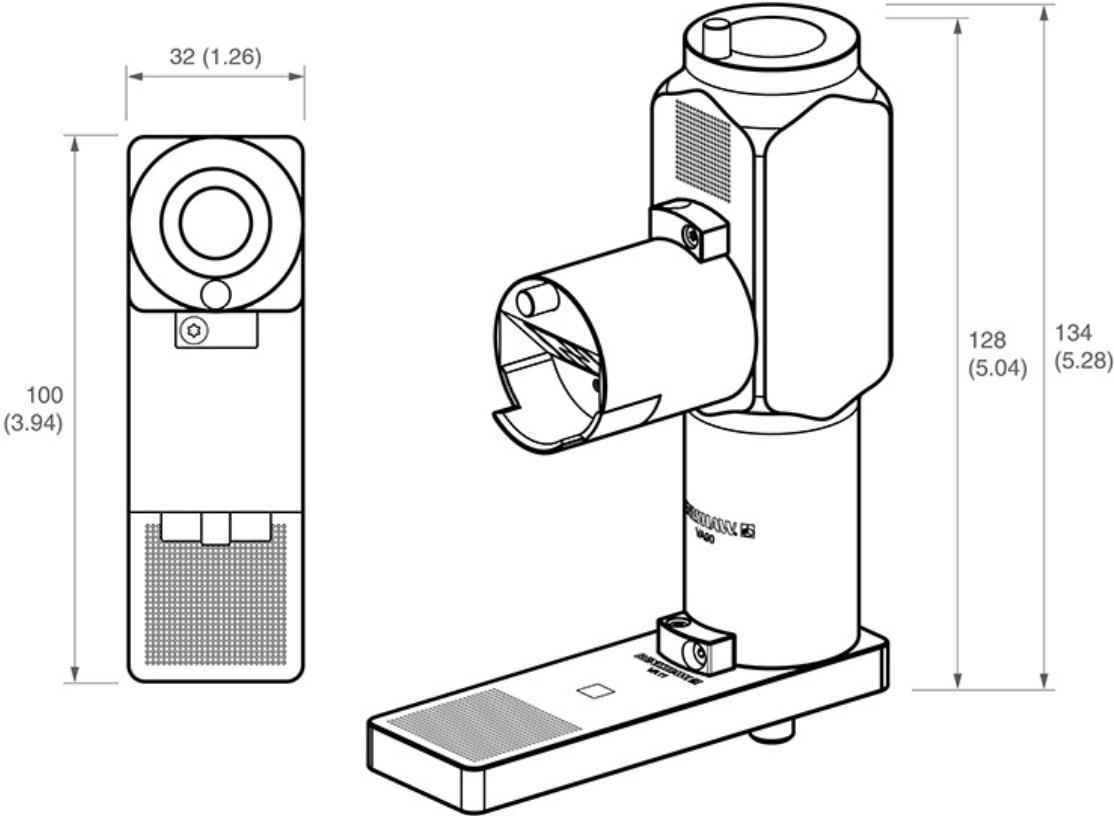

**i** NOTE: Dimensions in mm (in).

# RVP installation

## Fitting VPCP and VMCP to the MRS / MRS2 rack

The VPCP and VMCP heated change ports can be fixed to an MRS or MRS2 rack system. It is recommended that they are attached to the MRS / MRS2 rail using the following procedure, where it is assumed that the MRS / MRS2 rack system is correctly installed.

1. Insert one of the fixing screws through the VPCP / VMCP.
2. Position the VPCP / VMCP underneath the rail and locate the respective T-nut within the rail\*.
3. Hand tighten the fixing screw into the T-nut and repeat the process for the next fixing screw.
4. Position the VPCP / VMCP and tighten both fixing screws using the hexagonal key supplied.

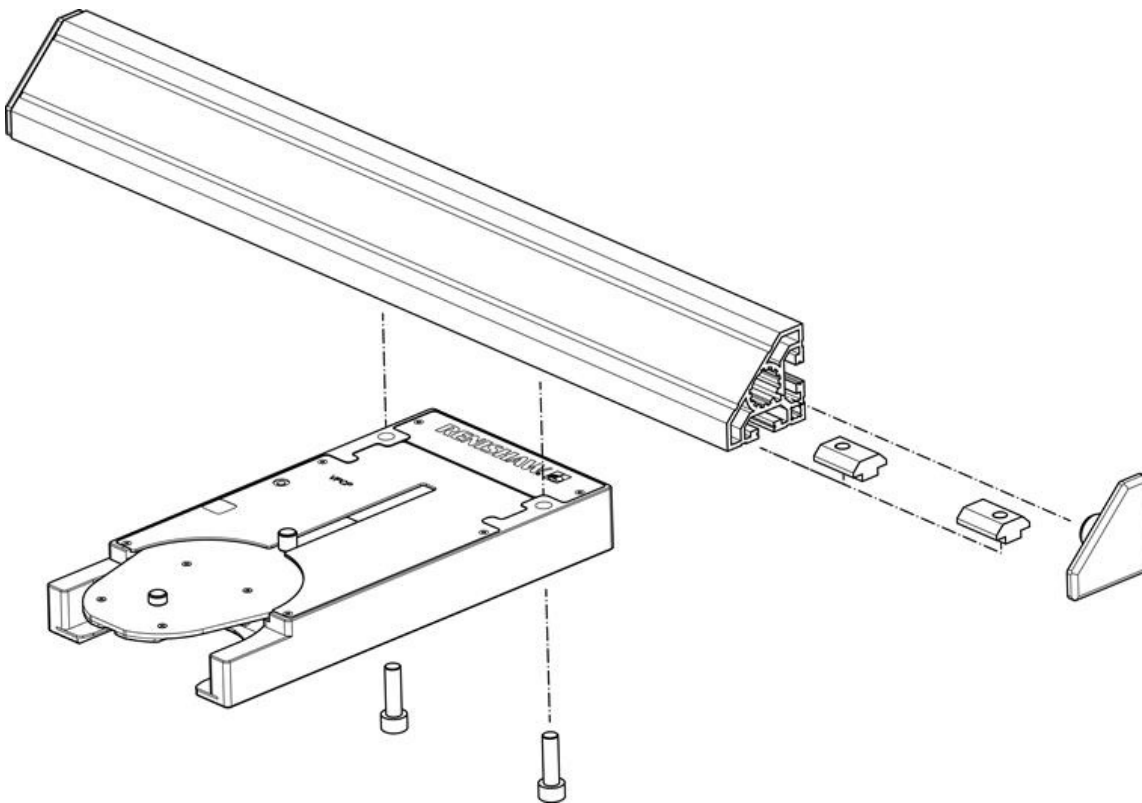

**i** **NOTE:** The image above shows the VPCP change port but the procedure is the same for the VMCP change port.

**i** \* **NOTE:** T-nuts must be used with the MRS system. However T-nuts and D-nuts are compatible with the MRS2 system.

**i** **NOTE:** Please refer to the REVO-2 change port system spacing guide (Renishaw part number H-1000-5408) for full details of the recommended spacing for positioning all sensors and artefacts on the MRS / MRS2 rail.

## RVP user's guide

www.renishaw.com

### Fixing VA11 calibration artefact and VA90 to CMM

The VA11 calibration artefact is designed to be fixed securely to the bed of the CMM to allow accurate and repeatable calibration of the RVP system components. The diagrams below show how to fix the VA11 to the bed of the CMM.

1. Locate an appropriate threaded hole in the bed of the machine.
2. Position the artefact plate above the threaded hole.
3. Screw the correct cap head bolt through the hole into the threaded hole on the machine. The supplied washer can be used to correctly fit smaller diameter bolts.
4. Tighten with a hex wrench.
5. Attach the calibration pillar to the kinematic mount. Integral magnets will secure it in place. Polarisation of the magnets will ensure the pillar is fitted in the correct orientation.
6. For use with ACM, VA90 can be fitted to the VA11 kinematic mount and the calibration pillar fitted instead to the kinematic mount on the VA90.

### Securing the pillar / VA90

The VA11 pillar and VA90 can optionally be secured to the baseplate or each other using the supplied bracket and screws.

1. Fix the VA11 baseplate to the bed of the CMM before securing the pillar or VA90.
2. Position the bracket with the curved face towards the pillar.
3. Attach the bracket to the baseplate or VA90 using the supplied M2 cap head screw and tighten with a hex wrench.
4. Screw the M2 shoulder bolt through the bracket into the pillar or VA90 and tighten with a hex wrench. Ensure the bolt is not overtightened, it should float within the bracket so as not to affect the kinematic location of the pillar or VA90.

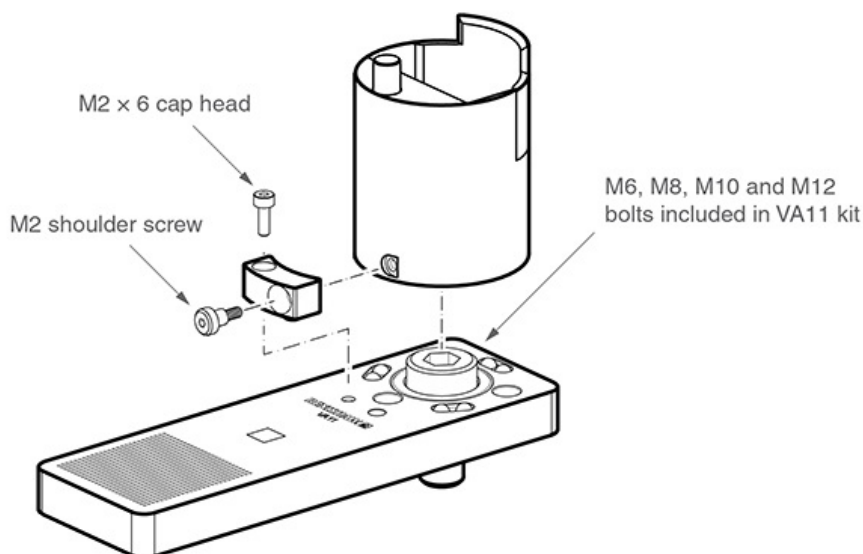

# RVP user's guide

[www.renishaw.com](http://www.renishaw.com)

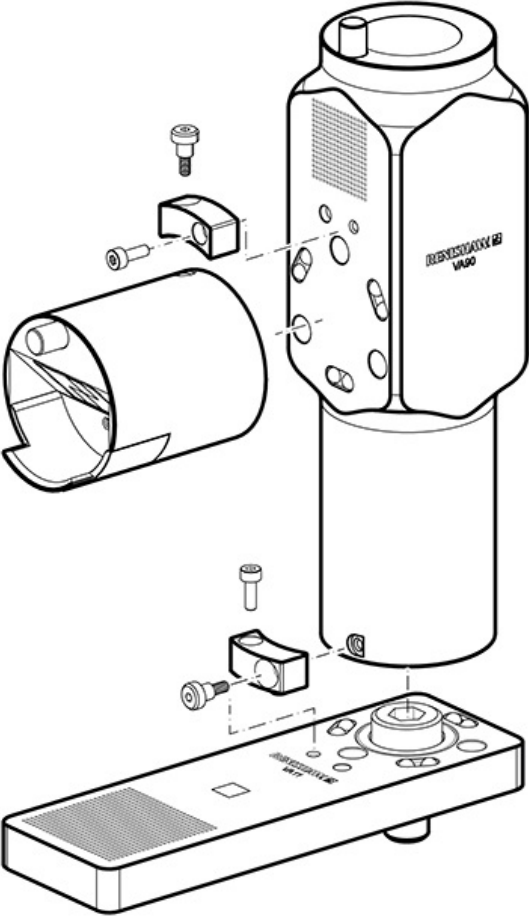

# Illumination options

## RVP lighting techniques

The RVP system has a number of illumination options to ensure that features can be correctly lit allowing accurate and consistent measurement. Both vision modules have integrated LED illumination to illuminate features that require inspection. The RVP system also uses a technique which uses back lighting to ensure good contrast of material edges or features.

The lighting technique chosen depends on the type of feature and the material of the part being inspected. RVP system image settings can be fully customised and adjusted to provide optimum contrast to inspect a range of features.

It is important that the correct exposure is achieved for both front and back lighting applications. The image on the left shows a correctly exposed back lit hole. The back edge of the hole is sharp and there is good contrast between the material and the white back lit panel.

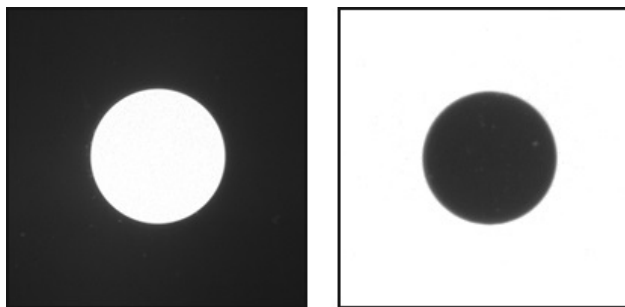

The image on the right shows a correctly exposed front lit feature. The front edge of the hole is sharp and there is good contrast between the dark material in the hole and the bright, front lit hole area. When using front lighting, more RVP image settings may need to be adjusted to get the optimum contrast and to reduce unwanted reflections.

## Ambient lighting

Ambient light is an important variable when using the RVP system. For accurate and repeatable inspection, the ambient environment lighting should be as consistent as possible. Any changes in ambient lighting can potentially affect the system's performance.



## RVP user's guide

www.renishaw.com

# Cleaning the RVP system

 **CAUTION:** Always adhere to the safety instructions given on the general safety recommendations and instructions in this document. Failure to do so could lead to personal injury.

Following the simple procedures given below will prolong the operational life and maintain the high performance of the system. The user should determine the frequency of inspection and maintenance actions according to the conditions of use.

## Kinematic couplings

The kinematic coupling mechanisms incorporated throughout the system have precision ball seating and permanent magnets. It is recommended that all these features be cleaned before first use, and thereafter at regular intervals.

A cleaning kit for the precision ball seating and permanent magnet is available from your Renishaw supplier (part number A-1085-0016). It comprises strips of yellow tack material. Use the yellow tack to clean the areas indicated with arrows numbered [1] on the image below.

With clean hands, tear off a small piece, shape into a small ball and press into / onto each of the features in turn, rotating to a fresh piece of material as you work around.

 **CAUTION:** Ensure no yellow tack debris is left on the surface. The yellow tack should not be used for the electrical contacts [2] or the optical windows [3].

## Electrical contacts

The electrical contacts, indicated with arrows numbered [2] in the image below, should be carefully cleaned with an alcohol-based cleaner (e.g. IPA) and a lint-free bud. The frequency of cleaning depends on the local environmental conditions, but should be at least every five hundred changes.

## RVP user's guide

www.renishaw.com

### Optical windows

The RVP probe and module optical windows should be cleaned using an optical lens cleaning kit to blow or brush debris away from the window. If debris is still visible, then the optical window should be carefully wiped with a lint free bud and high-purity isopropyl alcohol (IPA). Extreme care must be taken to avoid damaging the optical coating or scratching the glass. Latex gloves should be worn during the cleaning procedure and no attempt to directly touch the optical windows should be made.



**CAUTION:** Do not apply IPA directly to the optical windows. Apply to a lint free bud before wiping the optical windows. Never saturate or pour any liquid onto the optical windows.

**NOTE:** Cleanliness of the optical windows is important to maintain the highest level of performance of the probe and modules. If any contamination cannot be removed and is resulting in degraded metrology performance, please contact your local Renishaw office.

### ACM

ACM uses a first-surface mirror - the reflective coating is on the front surface of the glass, and is very delicate. Care must be taken to avoid touching the mirror surface to prevent contamination and damage. If cleaning is required, extreme care must be taken to prevent damage to the coating. Latex gloves should be worn during the cleaning procedure and no attempt to directly touch the mirror should be made.

Dust should be carefully removed from the mirror using a can of inert air (air duster) or blower bulb. To avoid depositing saliva on the surface, do not blow on the mirror. When using an air duster, try to avoid depositing the propellant on the mirror. Do not shake the can before use. Start the flow away from the mirror before carefully passing it over the surface at a grazing angle. Hold the can at least 150 mm (6 in) away from the mirror.

If necessary, the surface can be cleaned with optical grade solvents such as acetone or isopropyl alcohol and a clean wipe. Wipes must be soft and well wetted, do not use a dry wipe. Pure cotton wipes or balls, lens tissues and cotton tipped applicators are acceptable. Wipe the mirror surface softly and slowly, in short strokes.

Always use the supplied cover to protect the mirror from contamination when the ACM is not in use.

# RVP user's guide

www.renishaw.com

## Technical terminology

### Stand-off

This is the distance between the end of the vision module and the plane at which a feature will be at the sharpest focal distance to provide optimum image capture.

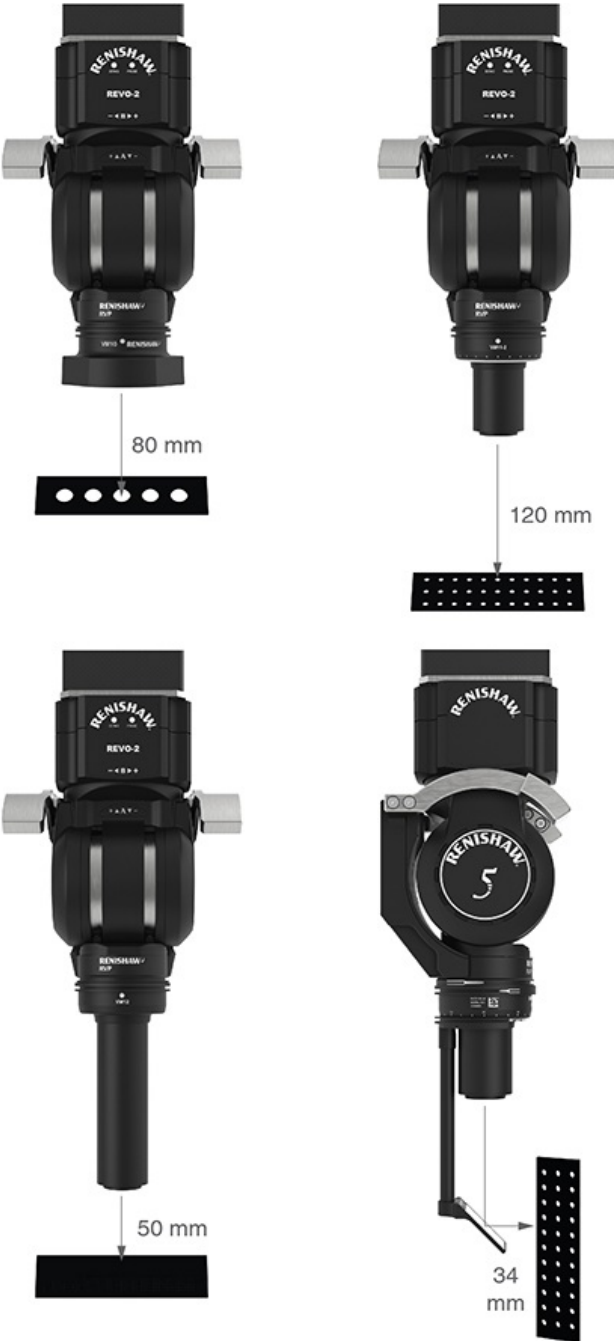

# RVP user's guide

www.renishaw.com

## Field of view

This is the maximum size area that will be projected onto the CMOS sensor when the correct stand-off distance is used. Any feature requiring inspection with RVP must be located within the field of view to allow inspection.



## RVP user's guide

www.renishaw.com

### Depth of field

The depth of field specifies the range over which a feature can deviate from the nominal stand-off distance and still be measured with acceptable levels of metrology performance. If features are measured outside the recommended depth of field range, metrology performance and accuracy will decrease.

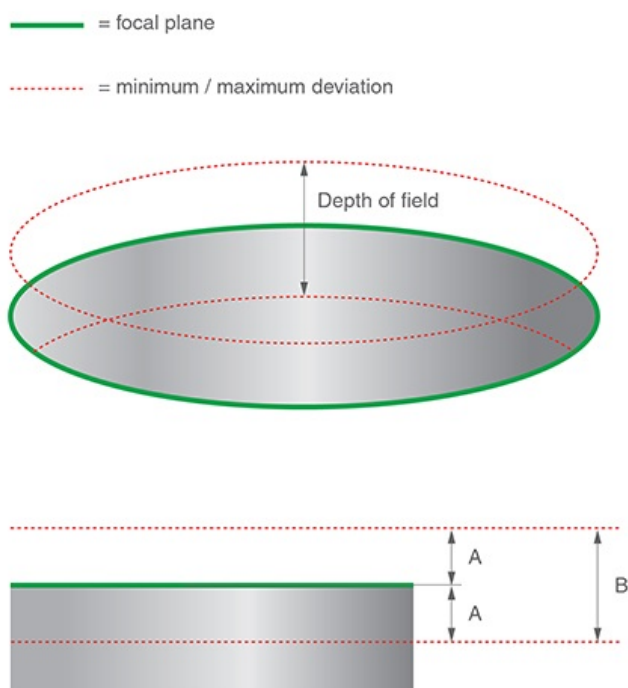

	VM10	VM11-2	VM12
A	2.5 mm	2.5 mm	0.1 mm
B	5 mm	5 mm	0.2 mm

**Renishaw plc**  
New Mills, Wotton-under-Edge  
Gloucestershire, GL12 8JR  
United Kingdom

**T** +44 (0)1453 524524  
**F** +44 (0)1453 524901  
[www.renishaw.com/cmmsupport](http://www.renishaw.com/cmmsupport)



**For worldwide contact details,  
please visit our main website at  
[www.renishaw.com/contact](http://www.renishaw.com/contact)**