

RMI-Q radio machine interface



Compliance information for this product is available by scanning the QR code or visiting www.renishaw.com/mtpdoc



Contents

Before you begin	1-1
Warranty	1-1
CNC machines	1-1
Care of the interface	1-1
Patents	1-1
Intended use	1-1
Radio probe family	1-2
Safety	1-2
RMI-Q basics	2-1
Introduction	2-1
Power supply	2-1
Input voltage ripple	2-2
RMI-Q visual diagnostics	2-2
Magnetic label	2-3
P1, P2, P3, P4 SYSTEM STATUS LEDs	2-3
LOW BATTERY / START LED	2-3
PROBE STATUS LED	2-4
ERROR LED	2-4
SIGNAL LED	2-4
RMI-Q inputs	2-5
RMI-Q outputs	2-5
RMI-Q output waveforms	2-7
RMI-Q seated start option	2-9
Switches SW1 and SW2	2-10
Switch SW1 output configuration	2-10
Switch SW2 output configuration	2-11
Remote external audible output	2-14
RMI-Q dimensions	2-15
RMI-Q specification	2-16
System installation	3-1
RMI to RMI-Q upgrade	3-1
Mounting bracket (optional)	3-2
Wiring diagram (with output groupings shown)	3-3
Radio probe – RMI-Q partnership	3-4
To partner the radio probe with the RMI-Q	3-4
Partnering radio probes configured for “multiple probe mode”	3-5

Partnering radio probes using ReniKey (recommended)	3-5
To partner up to four radio probes with the RMI-Q without ReniKey	3-6
Removing the radio probe from the RMI-Q	3-8
Changing radio probe position	3-8
RMI-Q cable	3-9
Cable sealing	3-9
Fitting flexible conduit	3-10
Screw torque values	3-11
Maintenance	4-1
RMI-Q cover	4-1
Removing the RMI-Q cover	4-1
Replacing the RMI-Q cover	4-2
Side exit to rear exit cable conversion	4-2
Fault-finding	5-1
Parts list	6-1

Before you begin

Warranty

Unless you and Renishaw have agreed and signed a separate written agreement, the equipment and/or software are sold subject to the Renishaw Standard Terms and Conditions supplied with such equipment and/or software, or available on request from your local Renishaw office.

Renishaw warrants its equipment and software for a limited period (as set out in the Standard Terms and Conditions), provided that they are installed and used exactly as defined in associated Renishaw documentation. You should consult these Standard Terms and Conditions to find out the full details of your warranty.

Equipment and/or software purchased by you from a third-party supplier is subject to separate terms and conditions supplied with such equipment and/or software. You should contact your third-party supplier for details.

CNC machines

CNC machine tools must always be operated by fully-trained personnel in accordance with the manufacturer's instructions.

Care of the interface

Keep system components clean.

Patents

Features of the RMI-Q, and other similar Renishaw products, are the subject of one or more of the following patents and/or patent applications:

CN 100466003	JP 4575781
CN 101482402	JP 5238749
EP 1576560	JP 5390719
EP 1931936	KR 1001244
EP 2216761	TW I333052
IN 215787	US 7665219
IN WO2004/057552	US 7821420
	US 9140547

Intended use

The RMI-Q, which acts as a combined radio transceiver and machine interface, converts signals from the radio probe into voltage-free solid state relay (SSR) and driven outputs for transmission to the CNC machine controller.

Radio probe family

The radio probe family currently consists of the RMP40, RMP40M, RLP40, RLP40H, RMP400, RMP60, RMP60M and RMP600. The RTS radio tool setter also forms part of Renishaw's family of radio transmission probes. The term radio probe used throughout this installation guide refers to both the probes and the tool setter.

Safety

Information to the user

In all applications involving the use of machine tools, eye protection is recommended.

Information to the machine supplier / installer

It is the machine supplier's responsibility to ensure that the user is made aware of any hazards involved in operation, including those mentioned in Renishaw product literature, and to ensure that adequate guards and safety interlocks are provided.

If the probe system fails, the probe signal may falsely indicate a probe seated condition. Do not rely on probe signals to halt the movement of the machine.

Information to the equipment installer

All Renishaw equipment is designed to comply with the relevant UK, EU and FCC regulatory requirements. It is the responsibility of the equipment installer to ensure that the following guidelines are adhered to, in order for the product to function in accordance with these regulations:

- Any interface MUST be installed in a position away from any potential sources of electrical noise (for example, power transformers, servo drives).
- All 0 V/ground connections should be connected to the machine "star point" (the "star point" is a single point return for all equipment ground and screen cables). This is very important and failure to adhere to this can cause a potential difference between grounds.
- All screens must be connected as outlined in the user instructions.
- Cables must not be routed alongside high current sources (for example, motor power supply cables), or be near high-speed data lines.
- Cable lengths should always be kept to a minimum.

Equipment operation

If this equipment is used in a manner not specified by the manufacturer, the protection provided by the equipment may be impaired.

RMI-Q basics

Introduction

CNC machine tools which are using Renishaw spindle probes with radio signal transmission for workpiece inspection, or tool setters with radio signal transmission, require a Renishaw radio machine interface (such as the RMI-Q) for signal transmission. The RMI-Q, which acts as a combined radio transceiver and machine interface, converts signals from the radio probe into voltage-free solid-state relay (SSR) and driven outputs for transmission to the CNC machine controller.

The RMI-Q is designed to be mounted within the machine's working envelope.

Application of the RMI-Q enables individual radio turn on and subsequent operation of up to four separate second-generation radio probes, permitting numerous combinations of radio inspection probes and/or radio tool setters to be used on the same machine tool.

RTS tool setters, and other second-generation radio probes, are easily identified by a 'Q' marking. First-generation radio probes, which do not have the 'Q' marking, may also be used with the RMI-Q. However, in machine tool applications where more than one radio probe is required, it is recommended that only second-generation radio probes are used. If a first-generation radio probe is used with the RMI-Q, any additional probes must be 'Q'-marked second-generation radio probes.

Optimum communication performance between the RMI-Q and the radio probe is achieved when the RMI-Q is aligned towards the radio probe, both positioned within the machine working environment. Other alignments within the machine working environment are permissible with negligible reduction in communication performance.

Mounting of the RMI-Q outside of the machine working envelope is possible but should be avoided, as communication performance may be reduced. For details about signal status, see "SIGNAL LED" on **page 2-4**.

CAUTION: RMI-Q operation of up to four separate radio probes is different to "multiple probe mode", which is a function of the radio probe that enables individual application of multiple probes but does not use radio turn on.

NOTE: When an RMI-Q is mounted outside of the machine working envelope, the communication to the radio probe will be via reflective surfaces such as floor, ceiling and walls. It is highly likely that the radio communication link will be subjected to external radio signals from other devices and will result in a less robust communication performance. A reflective path must not exceed 15 m (49.2 ft).

Power supply

The RMI-Q can draw its supply from the CNC machine tool's 12 Vdc to 30 Vdc supply and present a peak load of up to 500 mA during turn on (typically < 100 mA from 12 V to 30 V).

The RMI-Q has been designed to work over the specified supply voltage range and should be powered with a suitable protected extra low voltage supply (PELV). Renishaw cannot guarantee user safety if the RMI-Q is operated outside of these requirements.

Input voltage ripple

The input voltage ripple must not cause the voltage to fall below 12 V or rise above 30 V.

RMI-Q visual diagnostics

A visual indication of system status is provided by LEDs. Status is continuously updated and indication is provided for:

- P1, P2, P3, P4 SYSTEM STATUS;
- LOW BATTERY/START;
- PROBE STATUS;
- ERROR;
- SIGNAL CONDITION;

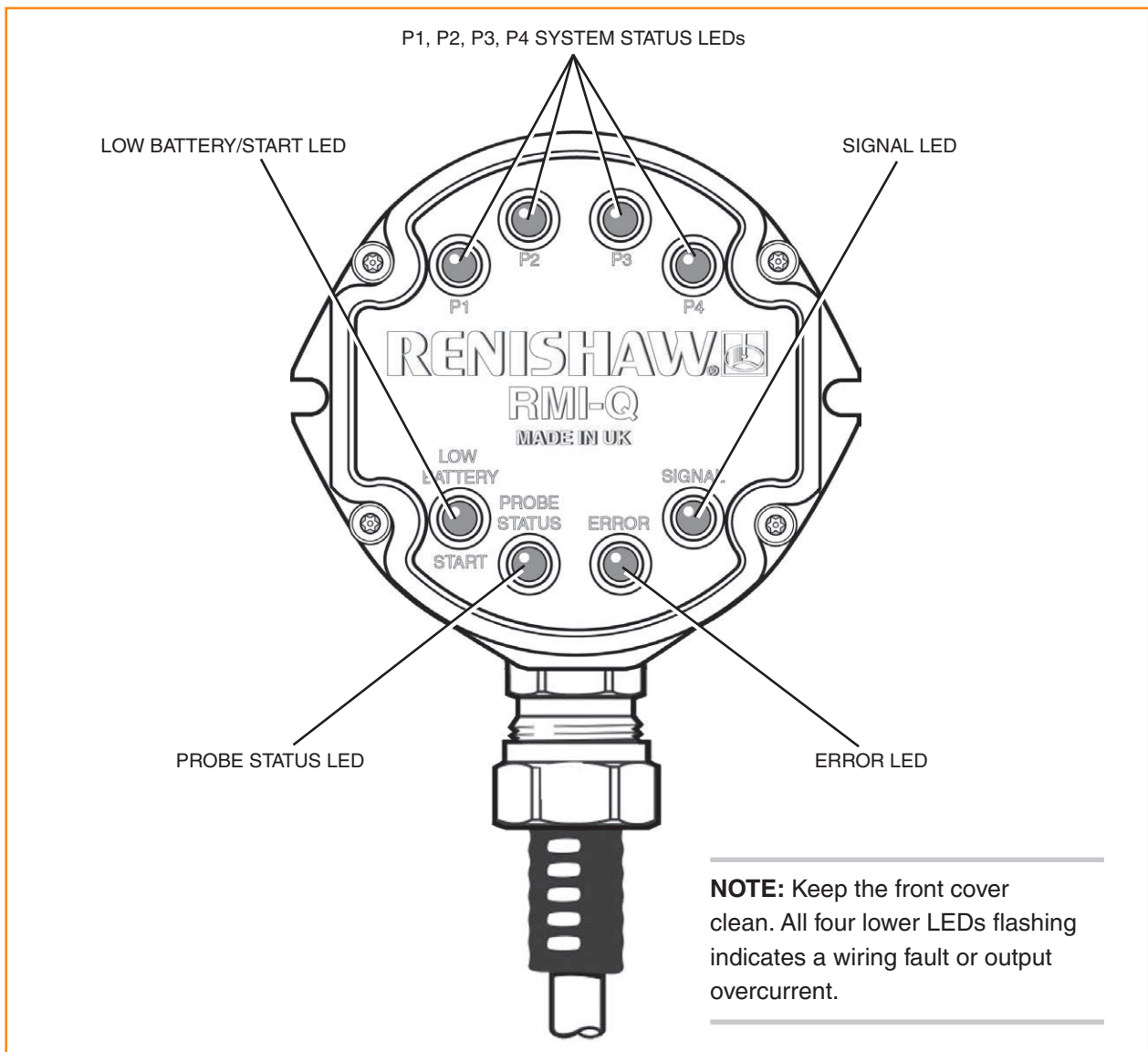

Magnetic label

A summary of RMI-Q activity is provided on a magnetic label. The label may be placed on any flat metal surface of the machine.

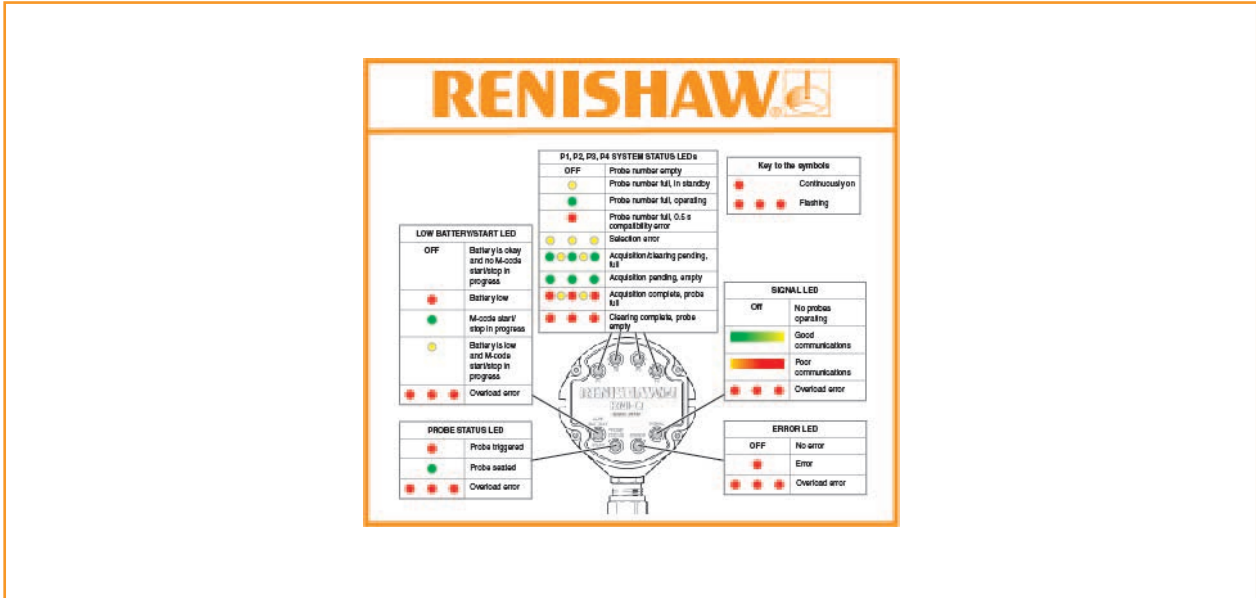

P1, P2, P3, P4 SYSTEM STATUS LED's

- Off – Probe number empty.
- Yellow – Probe number full, in standby.
- Green – Probe number full, operating.
- Red – Probe number full, 0.5 s compatibility error.
- Yellow/off – Flashing: Selection error.
- Green/yellow – Flashing: Acquisition/clearing pending, probe full.
- Green/off – Flashing: Acquisition pending, probe empty.
- Red/yellow – Flashing: Acquisition complete, probe full.
- Red/off – Flashing: Clearing complete, probe empty.

LOW BATTERY / START LED

- Off – Battery is OK and no M-code start/stop in progress.
- Red – Battery is low.
- Green – M-code start/stop in progress.
- Yellow – Battery low and M-code start/stop in progress.
- Red/off – Flashing: RMI-Q has an overcurrent condition.

PROBE STATUS LED

- Red – Probe triggered.
- Green – Probe seated.
- Red/off – Flashing: RMI-Q has an overcurrent condition.

ERROR LED

- Off – No error.
- Red – Error, other outputs may be incorrect.
- Red/off – Flashing: RMI-Q has an overcurrent condition.

SIGNAL LED

- Off – No probes operating.
- Green – Good communications.
- Green/yellow – Good communications.
- Red – Poor communications, radio link may fail.
- Red/off – Flashing: RMI-Q has an overcurrent condition.

NOTES:

The “PROBE STATUS” LED is always illuminated when power is present at the RMI-Q (as the RMI-Q does not incorporate a separate ‘power present’ indicator).

All LEDs report the status of the partner radio probe. If there is no partner in range, or the partner is off, the “PROBE STATUS” and “ERROR” LEDs will illuminate red. The “LOW BATTERY/START” and “SIGNAL” LEDs will be off.

When the RMI-Q is powered on it will enter the acquire partner mode. This is indicated by a flashing green “SIGNAL” LED (no change in outputs). After ~60 seconds it will switch to its normal mode listening for its partner.

The conditions shown by the “LOW BATTERY/START”, “PROBE STATUS” and “ERROR” LEDs are the same as those present on the electrical signal outputs.

RMI-Q inputs

Machine start inputs (P1, P2, P3, P4):

Machine start inputs are configurable as a level or pulsed signal.

P1	12 to 30 V (2.4 mA at 24 V) Dedicated start – level Common start – pulsed/level
P2, P3, P4	12 to 30 V (10 mA at 24 V) Dedicated start – level Common start – level

P1 machine start wires

(white positive and brown negative).

P2 machine start wires

(pink positive and brown negative).

P3 machine start wires

(white/red positive and brown negative).

P4 machine start wires

(white/blue positive and brown negative).

RMI-Q outputs

There are five outputs:

- Probe status 1 (SSR).
- Probe status 2a (5 V isolated driven skip).
- Probe status 2b (driven at power supply voltage).
- Error (SSR).
- Low battery (SSR).

All outputs can be inverted by using switches SW1 and SW2, (see “Switches SW1 and SW2” on [page 2-10](#)).

Probe status 1, Error, Low battery (SSR):

- ‘On’ resistance = 50 Ω max.
- Load voltage = 40 V max.
- Load current = 100 mA max.

Probe status 2a (5 V isolated driven skip):

- Load current = 50 mA max.

Output voltages

- Sourcing
 - = 4.2 V min. at 10 mA.
 - = 2.2 V min. at 50 mA.
- Sinking
 - = 0.4 V max. at 10 mA.
 - = 1.3 V max. at 50 mA.

Probe status 2b (driven at power supply voltage):

- Load current = 50 mA max.

Output voltages

- Sourcing voltage drop
 - = 4.2 V min. at 10 mA.
 - = 2.2 V min. at 50 mA.
- Sinking voltage drop
 - = 0.4 V max. at 10 mA.
 - = 1.3 V max. at 50 mA.

The “LOW BATTERY/START”, “PROBE STATUS”, “ERROR” and “SIGNAL” LEDs will start flashing red when an output overload has occurred. All outputs will be switched off. If this occurs, turn off the power supply and remove the source of the problem. Turning on the power supply will reset the RMI-Q.

CAUTIONS:

Power supply voltage

Do not exceed 30 V between: the black wire and the screen wire (green/yellow); the red wire and screen wire (green/yellow); or the red and black wires (power supply), as this could result in permanent damage to the RMI-Q and/or the customer power supply.

The use of in-line fuses at the machine cabinet end is recommended to provide protection for the RMI-Q and cable.

Screen connection

A good connection must be made to machine ground (“star point”).

Output stage circuit

Whilst the RMI-Q is powered, do not switch on / switch off output stages to enable/disable them as this could cause the overcurrent protection to switch off the output completely.

Ensure that outputs from the RMI-Q do not exceed specified current ratings.

RMI-Q output waveforms

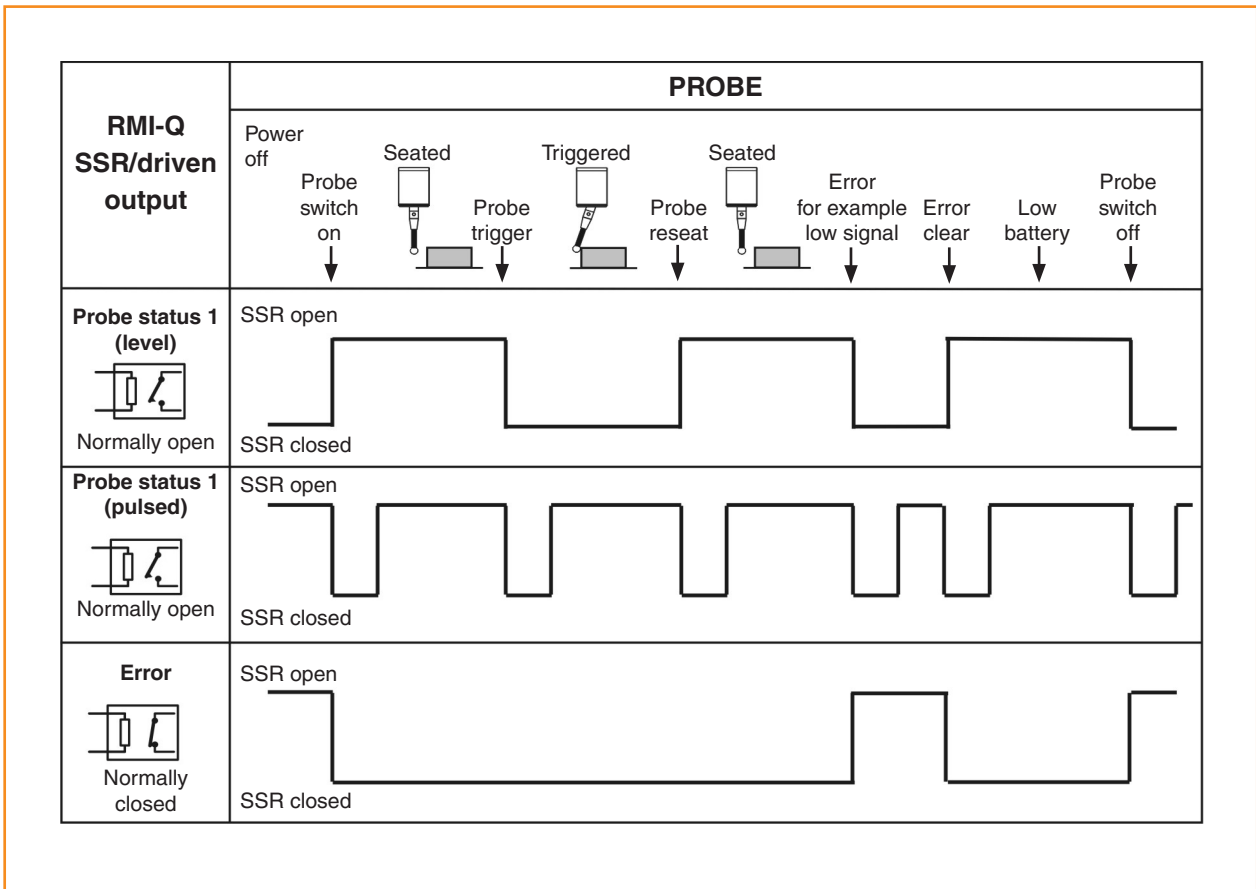

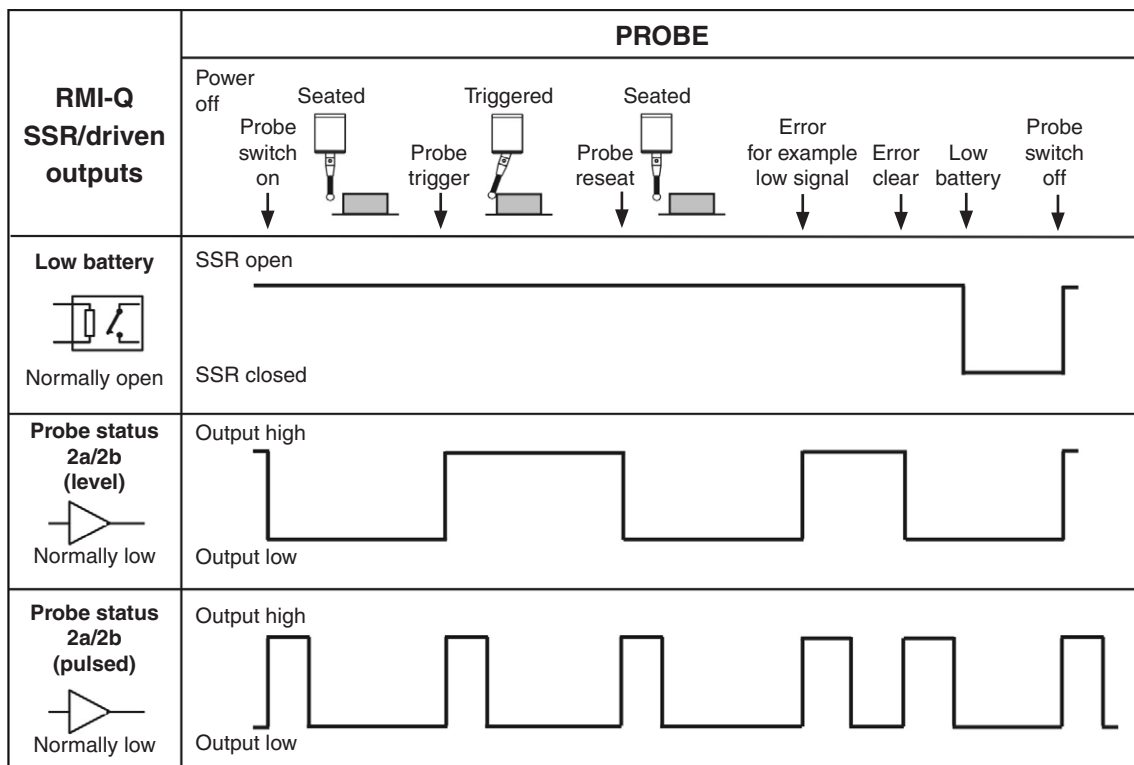

SIGNAL DELAYS

- 1. Transmission delay** Probe trigger to output change of state = 10 ms variation $\pm 10 \mu\text{s}$.
 (Enhanced trigger filter off)
- 2. Start delay** Time from initiation of start signal to valid signal transmission
 = 1 s max. (Standard turn on mode)

NOTE: Pulsed outputs are 40 ms ± 1 ms duration.

RMI-Q seated start option

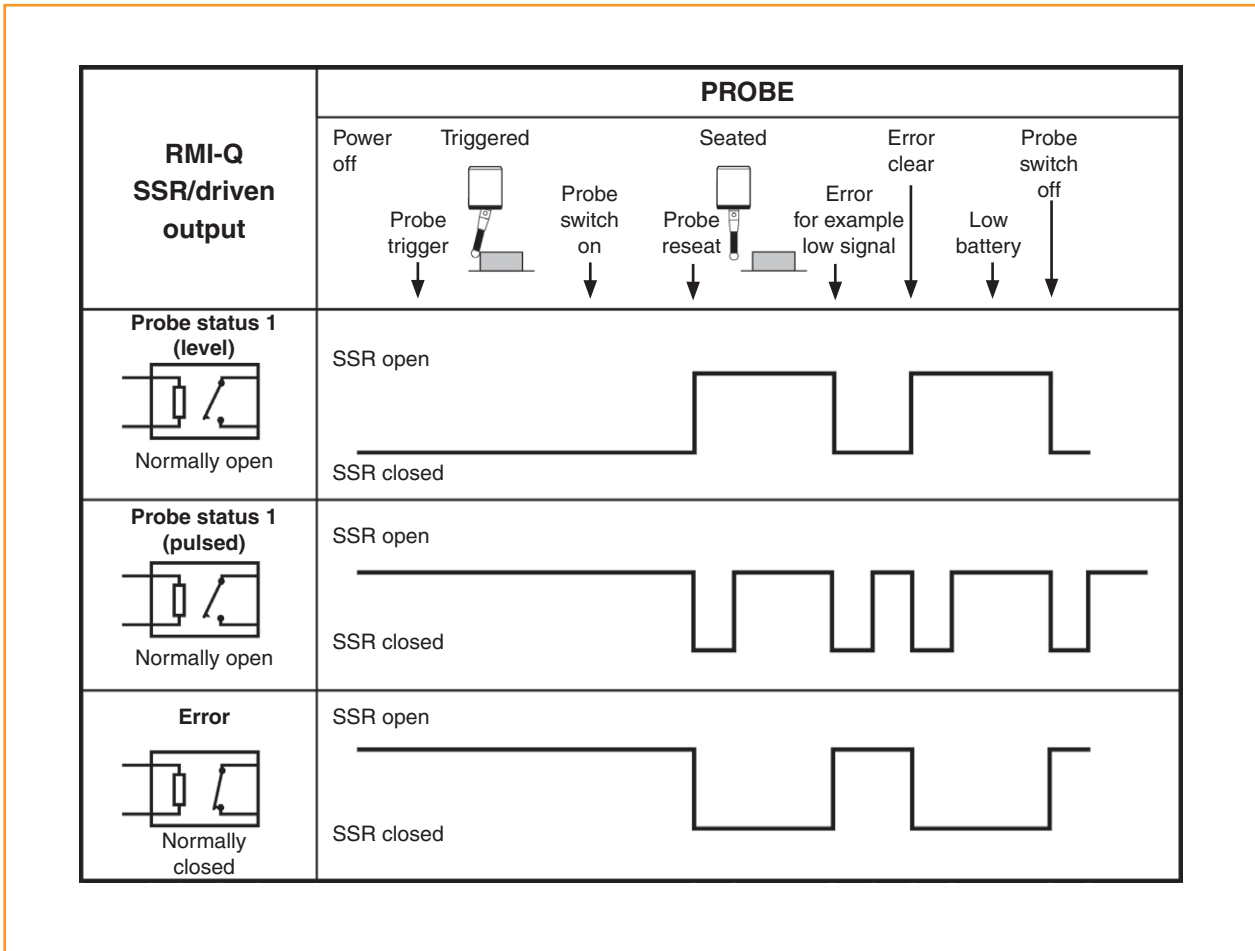

Switches SW1 and SW2

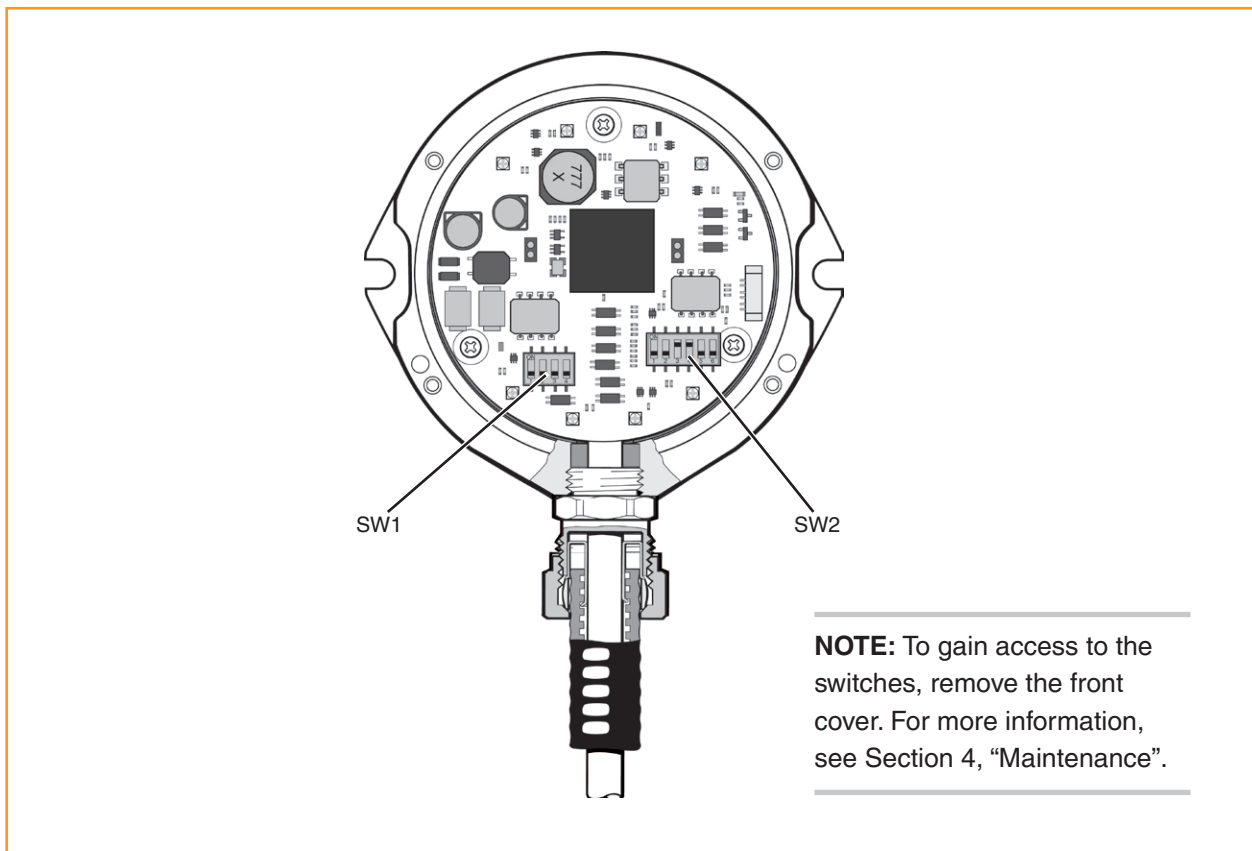

Switch SW1 output configuration

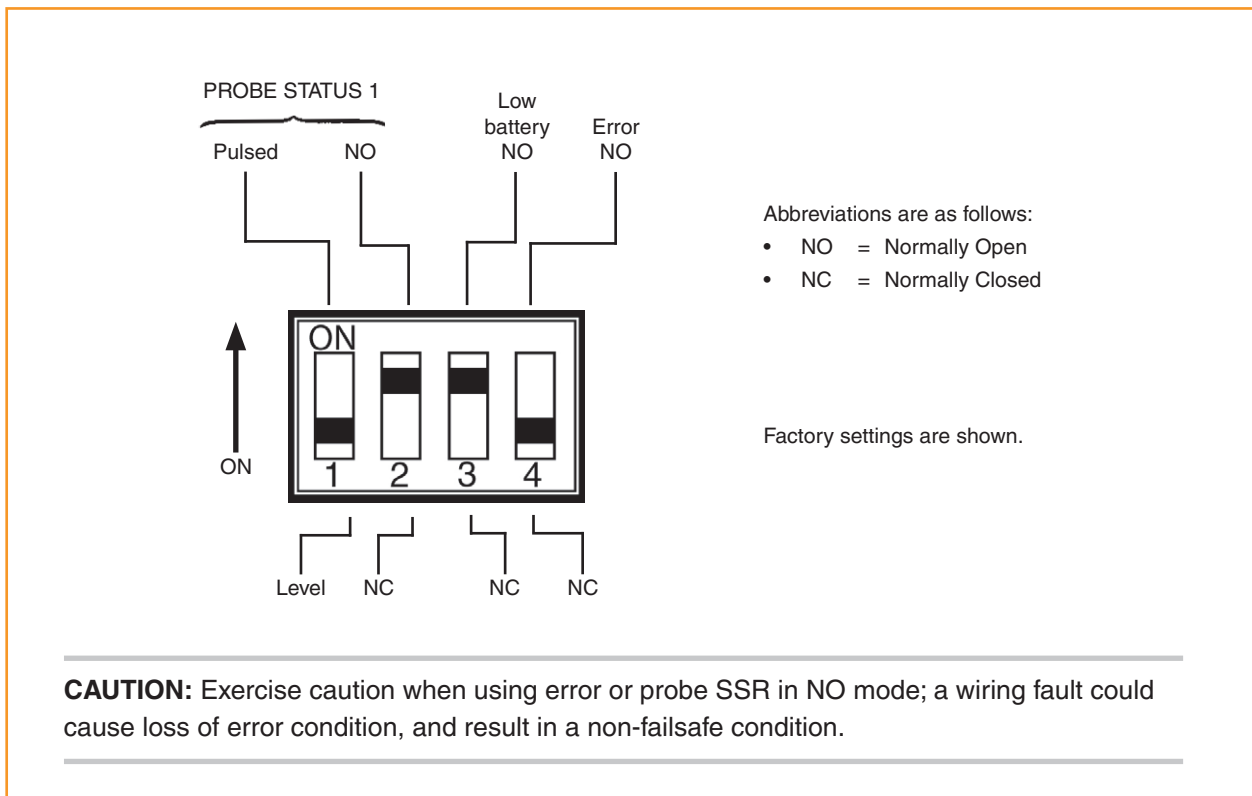

Switch SW2 output configuration

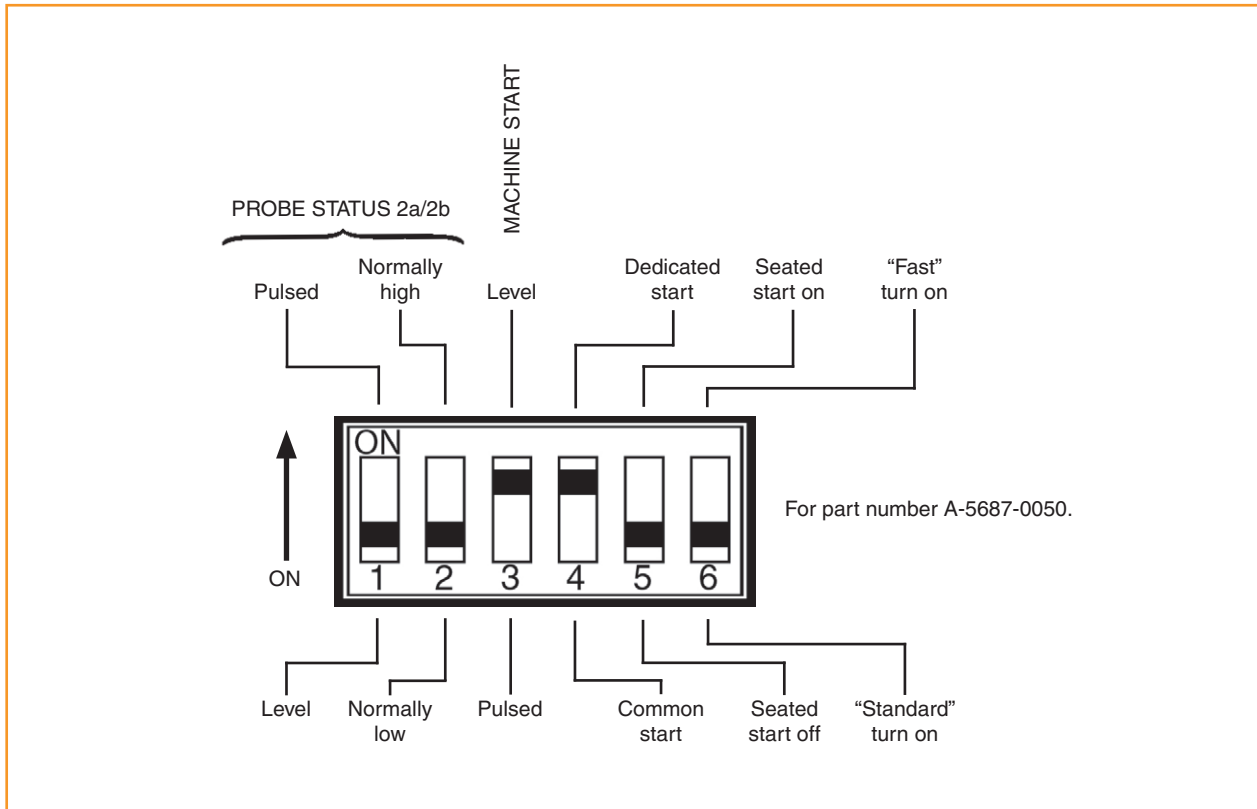

Seated start on

When seated start on is selected, the RMI-Q will not drop the error line until the radio probe has become seated. This provides compatibility with controllers that regard the radio probe to be in error if it is started in a triggered condition.

"Fast" turn on

"Fast" turn on provides compatibility with controllers that have quicker response times, to give a reduced probing cycle time. By selecting "fast" turn on, the system turn-on time will be reduced by 0.5 seconds. This will also impact the probe's battery life. These turn-on times apply to radio M-code on only. See the appropriate probe installation guide for more details.

NOTES:

In a poor radio frequency (RF) environment, the turn-on time of first-generation radio probes may be extended.

"Fast" turn on cannot be used with first-generation radio probes.

Dedicated start (level mode)

In dedicated start, a machine start input is required for each probe that is configured for radio turn on.

Machine start inputs				Probe selected
P1	P2	P3	P4	
				None
★				Probe 1 on
	★			Probe 2 on
		★		Probe 3 on
			★	Probe 4 on

★ Machine start input active. Any attempt to turn on more than one probe simultaneously will result in an error condition.

NOTES:

Dedicated start (level mode) is not compatible with radio probes configured for radio M-code on / time out off.

When dedicated start is selected, machine start (SW2) defaults to level regardless of pole 3 position.

For RMI compatibility mode, ensure poles 4, 5 and 6 (SW2) are in the down position and set other poles to the required configuration.

Common start (level mode)

In common start (level mode), machine start inputs P2 and P3 are used to select the probe and machine start input P1 is used to start the selected probe. All inputs are level.

Machine start inputs P1, P2 and P3			Probe selected
Probe start P1	Probe selection inputs		
	P2	P3	
★			Probe 1
★	★		Probe 2
★		★	Probe 3
★	★	★	Probe 4

★ Machine start input active.
When P1 is off, all probes are off. When P1 is active, the selected probe will be on.





NOTES:

Any change to the probe selection inputs P2 and P3 whilst the probe is operating will result in an error condition.

Common start (level mode) is not compatible with radio probes configured for radio M-code on / time out off.

Common start (pulsed mode)

In common start (pulsed mode), machine start inputs P2 and P3 are level inputs used to select the probe. Machine start input P1 is a pulsed input used to start the selected probe.

Machine start inputs P1, P2 and P3			Probe selected
Probe start P1	Probe selection inputs		
	P2	P3	
			Probe 1
	★		Probe 2
		★	Probe 3
	★	★	Probe 4

 Machine start input pulsed, so selected probe will change state.

★ Probe selection inputs are level signals.

NOTES:

Machine start input P4 is not used in common start (level or pulsed mode).

Only the probe start signal P1 will be pulsed and will change the probe status between on and off. The probe selection inputs P2 and P3 will be level.

Remote external audible output

Any output (set to pulsed) can be utilised to operate an external remote audible indicator.

The audible indicator must comply with the output transistor specification:

- up to 50 mA.
- up to 30 V.

Wiring configurations are shown below.

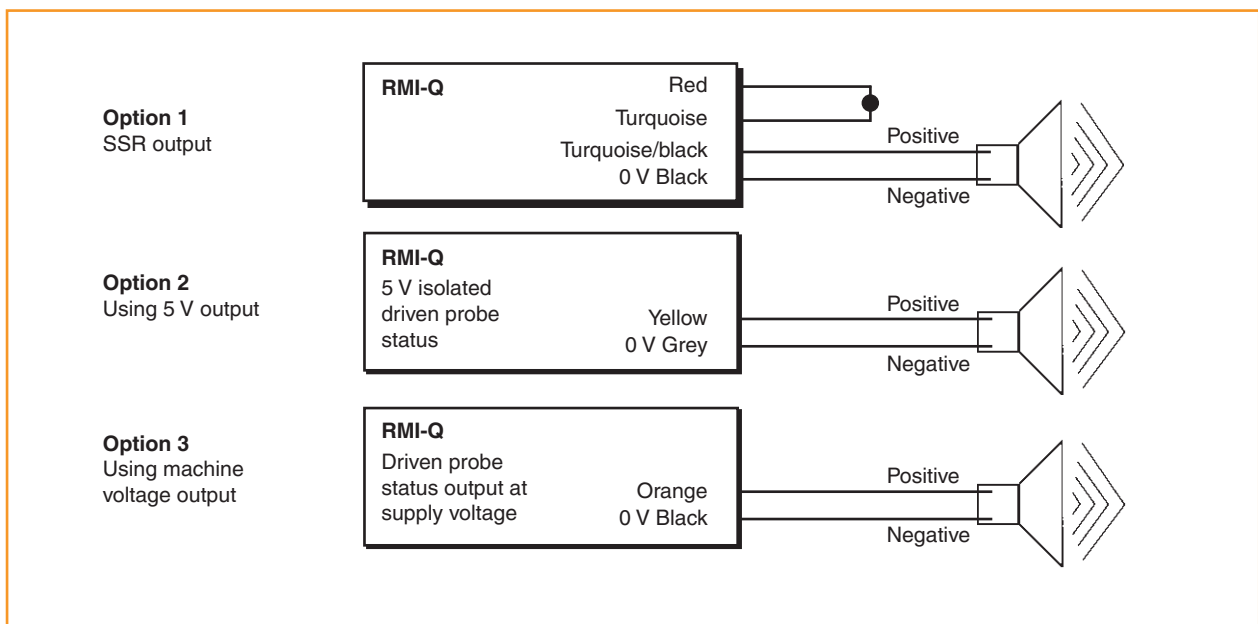

RMI-Q dimensions

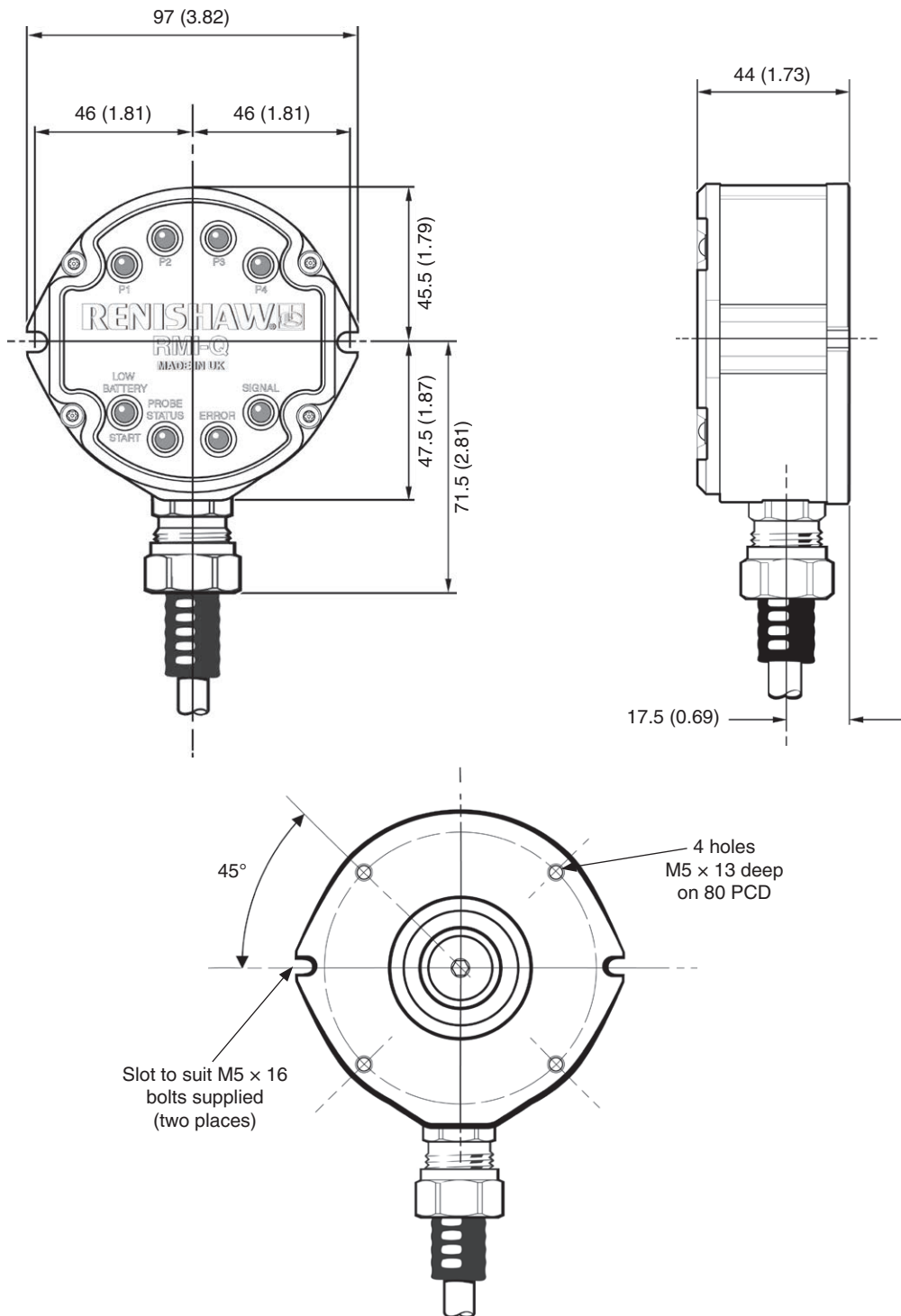

NOTE: When using a rear exit cable, provide a Ø25 mm (Ø1.0 in) hole in the mounting for the cable to exit.

Dimensions given in mm (in)

RMI-Q specification

Principal application		All machining centres, 5-axis machines, twin spindle machines and vertical turret lathes.						
Dimensions		<table border="1"> <tr> <td>Height</td> <td>117 mm (4.60 in)</td> </tr> <tr> <td>Width</td> <td>97 mm (3.82 in)</td> </tr> <tr> <td>Depth</td> <td>44 mm (1.73 in)</td> </tr> </table>	Height	117 mm (4.60 in)	Width	97 mm (3.82 in)	Depth	44 mm (1.73 in)
Height	117 mm (4.60 in)							
Width	97 mm (3.82 in)							
Depth	44 mm (1.73 in)							
Weight		RMI-Q including 8 m (26.2 ft) of cable = 1050 g (37.04 oz) RMI-Q including 15 m (49.2 ft) of cable = 1625 g (57.32 oz)						
Transmission type		Frequency hopping spread spectrum (FHSS) radio Radio frequency 2400 MHz to 2483.5 MHz						
Operating range		Up to 15 m (49.2 ft)						
Compatible probes ¹		Component setting/inspection: RMP40, RMP40M, RMP400, RMP60, RMP60M and RMP600 Lathe inspection: RLP40 and RLP40H Tool setting: RTS						
Supply voltage		12 Vdc to 30 Vdc						
Supply current		500 mA peak, < 100 mA typical from 12 V to 30 V						
Configurable M-code input		Pulsed or level						
Output signal		Probe Status 1, Low Battery, Error Voltage-free solid-state relay (SSR) outputs, configurable normally open or normally closed. Probe Status 2a 5 V isolated driven output, invertible. Probe Status 2b Power supply voltage driven output, invertible.						
Input / output protection		Supply protected by resettable fuse. Outputs protected by over current protection circuit.						
Diagnostic LEDs		Start, low battery, probe status, error, signal condition and P1, P2, P3, P4 system status.						
Cable (to machine controller)	Specification	Ø7.6 mm (0.30 in), 16-core screened cable, each core 18 × 0.1 mm						
	Length	8 m (26.2 ft) and 15 m (49.2 ft) standard lengths. Optional 30 m (98.4 ft) and 50 m (164.0 ft) cable assemblies are also available.						
Mounting		Flush mounting or directional mounting with optional mounting bracket (available separately).						
Environment		IP rating	IPX8, BS EN 60529:1992+A2:2013					
		Storage temperature	-25 °C to +70 °C (-13 °F to +158 °F)					
		Operating temperature	+5 °C to +55 °C (+41 °F to +131 °F)					

¹ For details of first-generation compatibility, see "Introduction" on page 2-1.

System installation

RMI to RMI-Q upgrade

To upgrade from an RMI to an RMI-Q, the following needs to be considered:

Mounting

The hole positions for mounting are the same on both the RMI and RMI-Q.

The mounting bracket is the same for both the RMI and RMI-Q. For further information on the mounting bracket, see “Mounting bracket” on **page 3-2**.

Cable

The cable for the RMI is 13-core, whereas for the RMI-Q it is 16-core (this is to allow for the extra probe inputs). For further information on the RMI-Q cable, see “RMI-Q cable” on **page 3-9**.

Wiring

Due to the extra cable cores, the wiring for the RMI-Q is slightly different to allow multiple radio probes or tool setters to be used. For instructions describing how to wire the probe, see “Wiring diagram” on **page 3-3**.

Switches

For instructions describing how to configure the switch settings to make the RMI-Q perform as an RMI, see Section 2, “RMI-Q basics”.

Partnering

The RMI-Q can be partnered using the same methods as the RMI. For instructions describing how to partner the RMI-Q, see “Radio probe – RMI-Q partnership” on **pages 3-4 to 3-8**. This section also details how to use the RMI-Q multiple probe functionality and ReniKey.

Mounting bracket (optional)

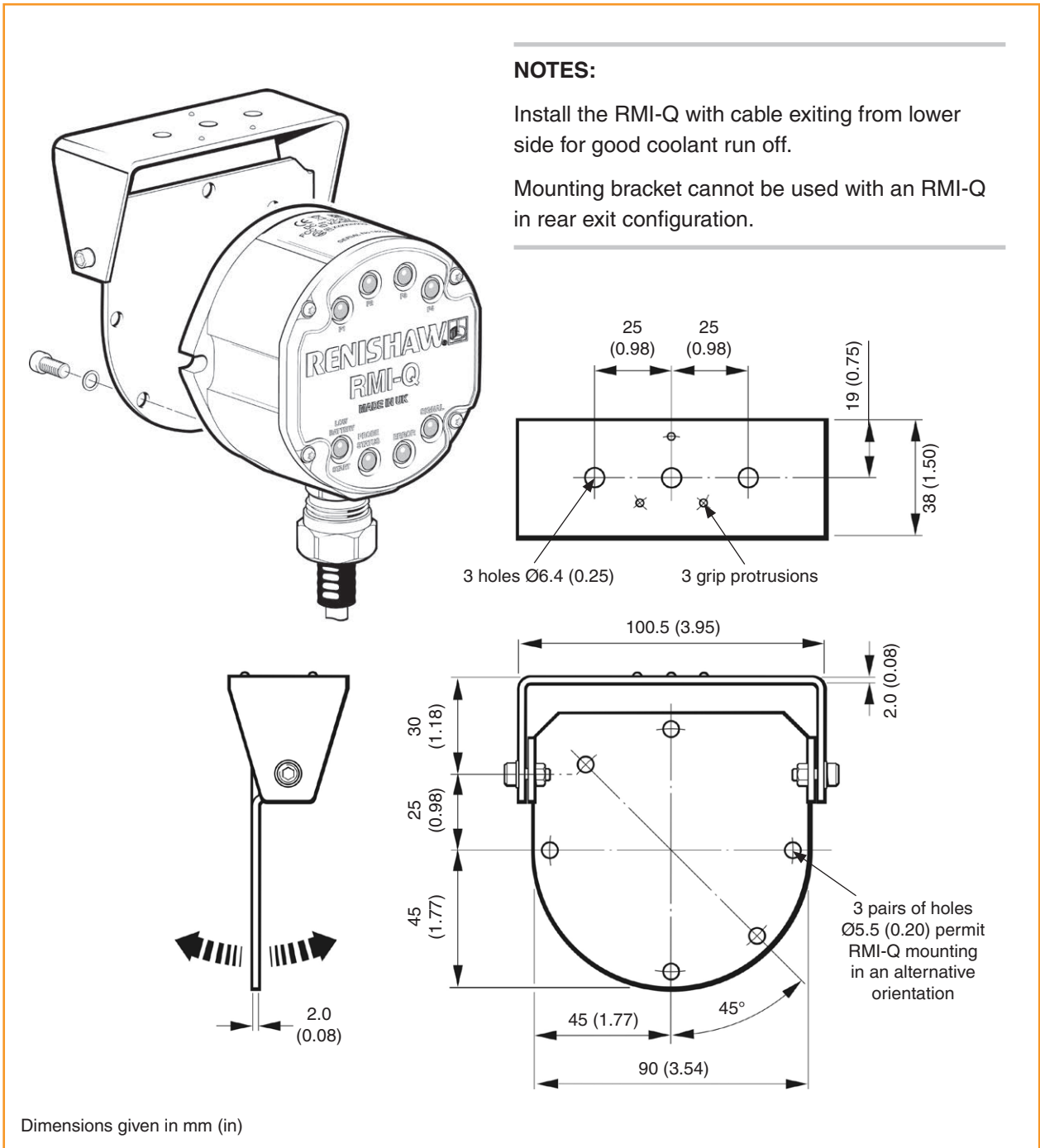

Wiring diagram (with output groupings shown)

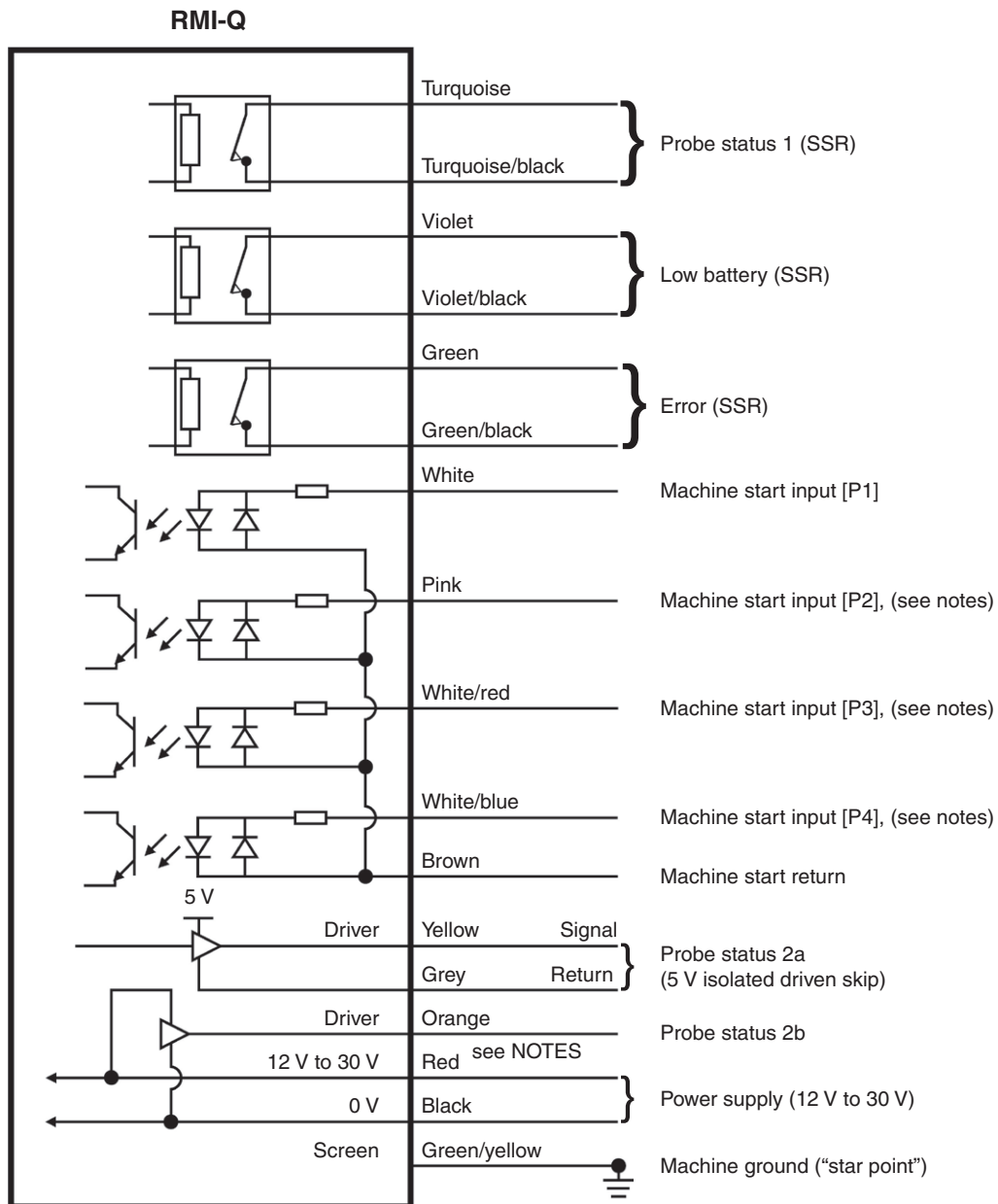

CAUTION: The power supply 0 V should be terminated at the machine ground ("star point"). A negative supply can be used when wired appropriately.

NOTES:

A switch can be fitted between the machine power supply and the red wire, to aid powering up the RMI-Q when partnering.

Inputs P2–P4 are the difference between RMI and RMI-Q wiring, as these inputs allow multiple radio probes or tool setters to be used.

Radio probe – RMI-Q partnership

The radio probe and RMI-Q must be placed into acquisition mode.

On the radio probe, acquisition mode is achieved using Trigger Logic™.

On the RMI-Q, acquisition mode is achieved either by manually power cycling the RMI-Q, or via application of ReniKey which is a Renishaw machine macro cycle.

Trigger Logic is a method that allows the user to view and select all available mode settings in order to customise a probe to suit a specific application. Trigger Logic is activated by battery insertion and uses a sequence of stylus deflection (triggering) to systematically lead the user through the available choices to allow selection of the required mode options.

Current probe settings can be reviewed by removing the batteries for a minimum of 5 seconds, and then replacing them to activate the Trigger Logic review sequence.

To partner the radio probe with the RMI-Q

Partnering is required during initial system set-up. Further partnering will be required if either the radio probe or RMI-Q are changed.

Any radio probe that is partnered with the RMI-Q, but then used with another system, will need to be cleared first from the RMI-Q before being partnered with the new system. The radio probe will also need to be partnered again should it be brought back to the RMI-Q.

Partnering will not be lost by reconfiguration of probe settings or when changing batteries.

NOTES:

The system will not function correctly if more than one partnered RMI-Q is within the transmission range of the radio probe.

Partnering will be lost when multiple probe mode is selected. “Multiple probe mode” is a function of the radio probe. See the relevant radio probe installation guide. For more information, see Section 6, “Parts list”.

To manually partner a single probe or tool setter with the RMI-Q:

1. Ensure the RMI-Q is powered down.
2. Use Trigger Logic to access radio probe or RTS configuration mode.
3. Configure switch-on method (if applicable).
4. Configure switch-off method (if applicable).
5. Configure enhanced trigger filter and auto reset function (if applicable).
6. Enter acquisition mode menu on the radio probe or RTS.

NOTE: Ensure the stylus is deflected momentarily at least every 20 seconds to remain in this mode.

7. Power on the RMI-Q.
8. Watch the RMI-Q P1 system status LED; after a couple of seconds the LED will repeatedly flash on and off green. This is the start of a 60 second interval in which the RMI-Q is in acquisition mode.
9. Deflect the stylus for less than 4 seconds to initiate the acquisition process.
10. After successful acquisition, the RMI-Q P1 system status LED will change to repeatedly flashing red and yellow (for 5 seconds) indicating that acquisition is complete and Probe 1 is full.
11. Leave the radio probe for 20 seconds to go into standby.
12. System is ready to use.

Partnering radio probes configured for “multiple probe mode”

“Multiple probe mode” is a function of the radio probe that enables individual application of multiple probes, but does not use radio turn on.

Radio probes using “multiple probe mode” can be stored in any of the RMI-Q locations. However, ‘Q’-marked second-generation radio probes cannot be mixed with non-‘Q’-marked radio probes in the same probe location when “multiple probe mode” is used.

Partnering radio probes using ReniKey (recommended)

ReniKey is a Renishaw machine macro cycle. It enables up to four radio probes to be partnered with the RMI-Q without the need to power the RMI-Q off and then back on for each of the probes being partnered.

For the part number of the ReniKey programming manual relevant to your controller, see Section 6, “Parts list”. For more information or to download ReniKey free of charge visit:

www.renishaw.com/mtpsupport/renikey

NOTES:

ReniKey can be applied to any of the four machine start inputs.

ReniKey cannot be used with “smart” M-codes; those M-codes which are associated with the machine’s PLC which, when activated, prompt the checking of the ERROR or PROBE STATUS outputs for example.

Partnering can take place anywhere within the operating envelope.

1. Use Trigger Logic™ to access radio probe or RTS configuration mode.
2. Configure switch-on method (if applicable).
3. Configure switch-off method (if applicable).
4. Configure enhanced trigger filter and auto reset function (if applicable).
5. Enter acquisition mode menu.

6. Apply one of the ReniKey commands. Refer to the ReniKey programming manual (for the part number relevant to your controller, see Section 6, “Parts list”).
7. Watch the RMI-Q corresponding system status LED; after a couple of seconds the LED will repeatedly flash on and off green. This is the start of a 60 second interval in which the RMI-Q is in acquisition mode.
8. Deflect the stylus for less than 4 seconds to initiate the acquisition process.
9. After successful acquisition, the RMI-Q respective system status LED will change to repeatedly flashing red and yellow (for 5 seconds) indicating that acquisition is complete and the slot is full.
10. Leave the radio probe for 20 seconds to go into standby.
11. Repeat steps 1 to 11 for each radio probe or RTS to be used with the RMI-Q ensuring each radio probe or RTS is assigned to a different slot each time ReniKey is applied (P1–P4).
12. System is ready to use.

CAUTION: When holding the radio probe, do not wrap a hand, or anything else, around the glass window.

NOTE: To check that turn on and off settings have not been accidentally changed, insert batteries to review current probe settings.

To partner up to four radio probes with the RMI-Q without ReniKey

The RMI-Q has four machine start inputs (P1–P4) that enable partnering of four radio probes (for more information, see “Wiring diagram” in Section 3, “System installation”).

The partnering procedure is dependent on the start method that has been selected (for more information, see “Start methods” in Section 2, “RMI-Q basics”).

Partnering with dedicated start (Level mode)

If the RMI-Q is powered with all start inputs held low, the RMI-Q will complete its start-up procedure and partner the radio probe as Probe 1.

When the RMI-Q is powered with a single machine start input held high, the RMI-Q will complete its start-up procedure and partner the radio probe to the probe number represented by the selected machine start input.

Level mode				
Probe to be partnered	Machine start input			
	P1	P2	P3	P4
Probe 1				
Probe 2		★		
Probe 3			★	
Probe 4				★

The system status LED for the selected probe number will repeatedly flash on and off green whilst in acquisition mode.

Partnering with common start

When the RMI-Q is powered, specific machine start inputs need to be held high when partnering the radio probe to a specific probe number.

Pulsed mode			
Probe to be partnered	Machine start input		
	P1	P2	P3
Probe 1			
Probe 2		★	
Probe 3			★
Probe 4		★	★

Level mode			
Probe to be partnered	Machine start input		
	P1	P2	P3
Probe 1			
Probe 2	★	★	
Probe 3	★		★
Probe 4	★	★	★

NOTES:

Activation of machine start input (P4) is not required when common start is selected.

To aid partnering, an on/off switch can be fitted between the machine power supply and the RMI-Q (red wire). This enables the RMI-Q to be momentarily powered off and then back on, for each of the probes being partnered, without having to power off the machine.

Removing the radio probe from the RMI-Q

A radio probe must be cleared from the RMI-Q when it is removed from the system. The probe number is cleared from the RMI-Q by repeating the partnering procedure whilst the corresponding machine start input is held high. The RMI-Q will then display that the probe number was cleared. Alternatively, the radio probe can be cleared via application of the ReniKey machine macro cycle.

ReniKey can also be used to clear all probe numbers at the same time. If the cleared radio probe is to be used again with the RMI-Q, it must be re-partnered.

Changing radio probe position

If, during partnering with all procedures, the RMI-Q acquires a radio probe that is already stored under a different probe number, the radio probe will be cleared from its current location and stored under the new probe number selected for acquisition.

RMI-Q cable

Cable termination

A ferrule should be crimped onto each cable wire for a more positive connection at the terminal box.

Standard cable variants

The RMI-Q standard cables are 8 m (26.2 ft) and 15 m (49.2 ft) long.

Longer cables are available; for more information, see Section 6, “Parts list”.

Cable specification

Ø7.6 mm (0.3 in), 16-core screened cable, each core 18 × 0.1 mm.

NOTE:

Maximum cable length:

30 m (98.42 ft) at 12 V

50 m (164.04 ft) at 24 V

Cable sealing

Coolant and dirt are prevented from entering the RMI-Q by the cable sealing gland. The RMI-Q cable can be protected against physical damage by fitting a flexible conduit if required.

The recommended flexible conduit is Anamet™ Sealtite HFX (5/16 in) polyurethane.

A conduit kit is available; for more information, see Section 6, “Parts list”.

CAUTIONS:

Failure to adequately protect the cable can result in system failure due to either cable damage or coolant ingress through cores into the RMI-Q.

Failure due to inadequate cable protection will invalidate the warranty.

When tightening or loosening nut **B** on the conduit, ensure that torque is only applied between **A** and **B**.

Fitting flexible conduit

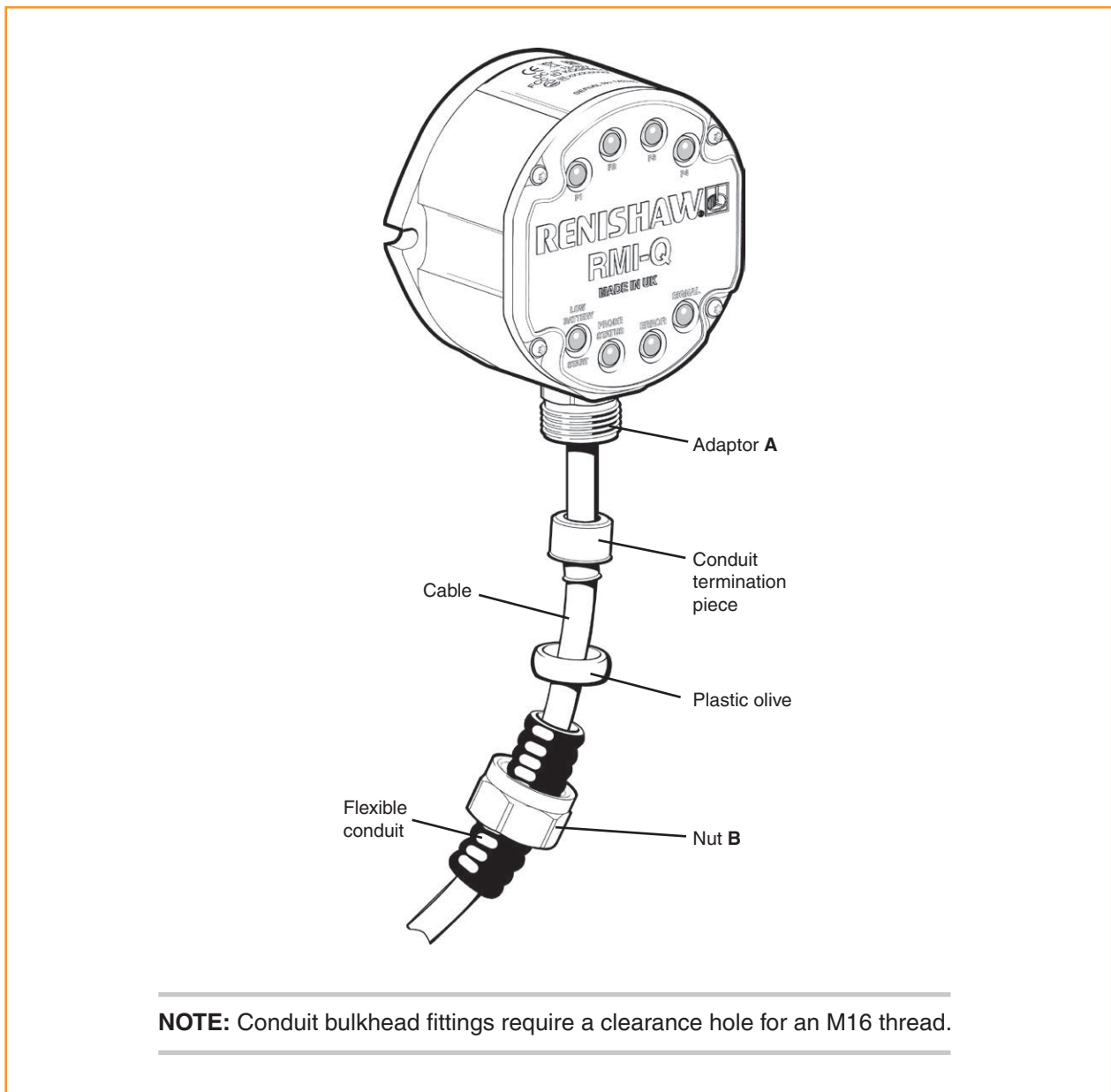

1. Slide nut **B** and the plastic olive onto the conduit.
2. Screw the conduit termination piece into the end of the conduit.
3. Fit the conduit to adaptor **A** and tighten nut **B**.

Screw torque values

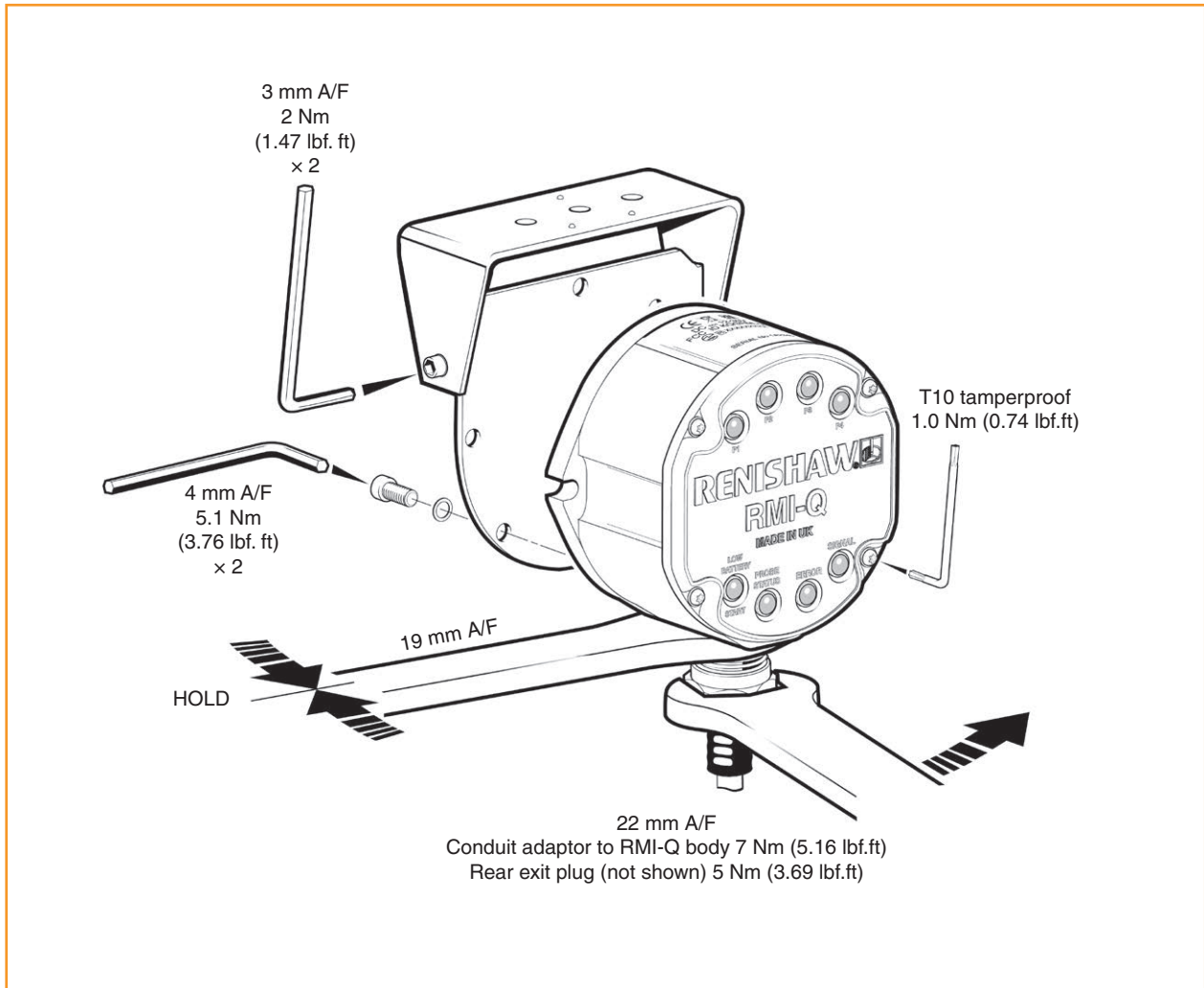

This page is intentionally left blank.

Maintenance

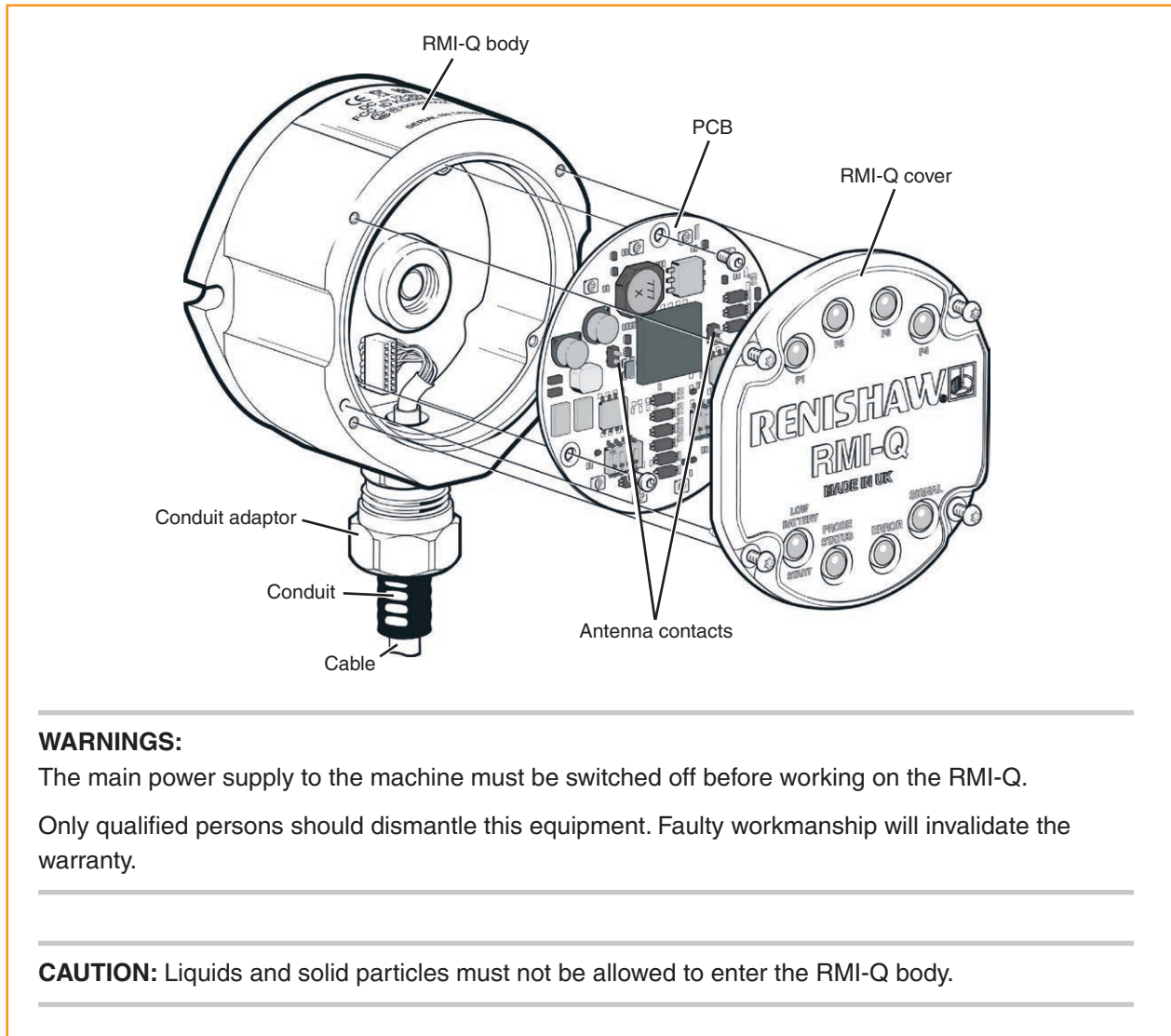

WARNINGS:

The main power supply to the machine must be switched off before working on the RMI-Q.
Only qualified persons should dismantle this equipment. Faulty workmanship will invalidate the warranty.

CAUTION: Liquids and solid particles must not be allowed to enter the RMI-Q body.

RMI-Q cover

It is not necessary to remove the RMI-Q from the machine when adjusting the switches or installing replacement parts. For torque settings, see “Screw torque values” in Section 3, “System installation”.

The front cover may be removed and replaced, as detailed in this section, if there is a need to change configuration.

Removing the RMI-Q cover

1. Clean the RMI-Q thoroughly before servicing to ensure no debris or coolant enters the unit.
2. Using the T10 tamperproof key (provided), unscrew (but do not remove) each captive screw and washer evenly from the cover.

When removing the cover, do not twist or rotate by hand.

Replacing the RMI-Q cover

1. Remove the O-ring from the cover. Ensure that the O-ring, the O-ring groove and the cover sealing face are clean. Lubricate the O-ring with silicone grease and refit to the cover.
2. Ensure that the O-ring seating on the RMI-Q body is clean, and that there are no scratch marks which could prevent complete sealing.
3. Ensure that the antenna contacts are clean.
4. Place the cover, complete with O-ring, onto the RMI-Q body.

CAUTION: Do not overtighten the cover as distortion could occur.

NOTE: The O-ring should be lubricated with silicone grease to prevent damage. Do not allow grease to contaminate the antenna contacts.

5. Tighten each captive screw and washer a few turns at a time, to pull the cover down evenly. Screw torque is 1.0 Nm (0.74 lbf.ft.).

Side exit to rear exit cable conversion

CAUTION: Conversion from side exit cable to rear exit cable must only be undertaken by qualified personnel. Failure to do so will invalidate the warranty.

1. Remove RMI-Q cover. For instructions describing how to remove the RMI-Q cover, see “Removing the RMI-Q cover” on **page 4-1**.
2. Remove the three crosshead screws retaining the PCB. Carefully remove the PCB and disconnect the cable connection to the PCB.
3. Unscrew the conduit gland from the RMI-Q body.
4. Unscrew the rear exit plug and rubber grommet from the RMI-Q body.
5. Carefully remove the cable assembly and refit through the rear exit hole. Tighten the conduit gland. For torque settings see “Screw torque values” in Section 3, “System installation”.
6. Fit the rubber grommet and rear exit plug to the side exit hole and tighten.
7. Connect the PCB to the cable connector. Insert the PCB and retain with the three cross head screws. For torque settings see “Screw torque values” in Section 3, “System installation”.
8. Fit the RMI-Q cover. For instructions describing how to replace the RMI-Q cover, see “Replacing the RMI-Q cover” on **page 4-2**.

Fault-finding

Symptom	Cause	Action
No LEDs lit on RMI-Q.	Overvoltage, undervoltage or no power.	Check voltage supply.
	Damaged cable.	Check wiring.
RMI-Q status LEDs do not correspond to radio probe status LEDs.	Radio link failure – radio probe out of RMI-Q range.	Check position of RMI-Q, refer to the operating envelope in the relevant radio probe installation guide. For more information, see Section 6, “Parts list”.
	Radio probe has been enclosed/shielded by metal.	Review installation.
	Radio probe and RMI-Q are not partnered.	Partner radio probe and RMI-Q.
RMI-Q error LED illuminated. For more information, see “ERROR LED” in Section 2, “RMI-Q basics”.	Radio probe and RMI-Q are not partnered.	Partner radio probe and RMI-Q.
	Exhausted radio probe batteries.	Change radio probe batteries.
	Probe not switched on.	Check configuration and alter as required.
	Probe out of range.	Check position of RMI-Q, refer to the operating envelope in the relevant radio probe installation guide. For more information, see Section 6, “Parts list”.
	Probe selection error.	Verify that one radio probe is working and is correctly selected.
All four lower LEDs flashing.	Wiring fault.	Check wiring.
	Output overcurrent.	Check wiring, turn power to RMI-Q off and on again to reset.
RMI-Q low battery LED lit.	Low radio probe batteries.	Change radio probe batteries soon.
Reduced range.	Local radio interference.	Identify and remove.
	Radio probe has been enclosed/shielded by metal.	Review installation.
RMI-Q system status LED continually lit red.	Radio probe is not compatible with RMI-QE.	Use a radio probe with a ‘Q’ marking.
Probe will not turn off.	Time out off used with level start option.	Review system set-up.

This page is intentionally left blank.

Parts list

Type	Part number	Description
RMI-Q	A-5687-0049	RMI-Q with 8 m (26.2 ft) cable, tools, support card and radio approval label.
RMI-Q	A-5687-0050	RMI-Q with 15 m (49.2 ft) cable, tools, support card and radio approval label.
RMI-Q	A-5687-1050	RMI-Q with 15 m (49.2 ft) cable, tools, support card and radio approval label (switches set for RMI compatibility mode).
Mounting bracket	A-2033-0830	Mounting bracket.
Conduit	A-4113-0306	Conduit set with 1 m (3.28 ft) of polyurethane conduit and bulkhead connector (M16 thread).
Cover assembly	A-5687-0305	Cover/antenna assembly: including cover screws, torx key and O-ring.
Cable assembly	A-5687-0306	Cable assembly 8 m (26.2 ft) long.
Cable assembly	A-5687-0302	Cable assembly 15 m (49.2 ft) long.
Cable assembly	A-5687-0303	Cable assembly 30 m (98.4 ft) long.
Cable assembly	A-5687-0304	Cable assembly 50 m (164.0 ft) long.
Tools	A-4113-0300	Comprising: 1 × T10 tamperproof key, 1 × 4 mm hex key, 14 × ferrules, 4 × M5 screws, 2 × M5 nut, 4 × M5 washers, 1 × O-ring (Ø34.5 × 3 mm).
RMI-Q support software	A-5687-5000	ReniKey machine macro cycles with programming manual and macro software for multiple RTS.
Publications. These can be downloaded from our website at www.renishaw.com		
RMP60	H-5742-8504	Installation guide: for set-up of the RMP60 probe.
RMP600	H-5312-8503	Installation guide: for set-up of the RMP600 probe.
RMP40	H-5480-8504	Installation guide: for set-up of the RMP40 probe.
RLP40	H-5627-8504	Installation guide: for set-up of the RLP40 probe.
RMP400	H-6570-8501	Installation guide: for set-up of the RMP400 probe.
RTS	H-5646-8504	Installation guide: for set-up of the RTS tool setting probe.
RenKey (generic)	H-5687-8601	Programming guide: ReniKey software (generic).
RenKey (Heidenhain)	H-5687-8602	Programming guide: ReniKey software (Heidenhain).
RenKey (Siemens)	H-5687-8603	Programming guide: ReniKey software (Siemens).
Styli	H-1000-3200	Technical specifications: Styli and accessories – or visit our Online store at www.renishaw.com/shop .
Probe software	H-2000-2298	Data sheet: <i>Probe software for machine tools – programs and features.</i>

NOTE: The serial number of each RMI-Q is found on the top of the housing.

www.renishaw.com/rmi-q



#renishaw

 +44 (0) 1453 524524

 uk@renishaw.com

© 2012–2022 Renishaw plc. All rights reserved. This document may not be copied or reproduced in whole or in part, or transferred to any other media or language by any means, without the prior written permission of Renishaw.

RENISHAW® and the probe symbol are registered trade marks of Renishaw plc. Renishaw product names, designations and the mark 'apply innovation' are trade marks of Renishaw plc or its subsidiaries. Other brand, product or company names are trade marks of their respective owners.

WHILE CONSIDERABLE EFFORT WAS MADE TO VERIFY THE ACCURACY OF THIS DOCUMENT AT PUBLICATION, ALL WARRANTIES, CONDITIONS, REPRESENTATIONS AND LIABILITY, HOWSOEVER ARISING, ARE EXCLUDED TO THE EXTENT PERMITTED BY LAW. RENISHAW RESERVES THE RIGHT TO MAKE CHANGES TO THIS DOCUMENT AND TO THE EQUIPMENT, AND/OR SOFTWARE AND THE SPECIFICATION DESCRIBED HEREIN WITHOUT OBLIGATION TO PROVIDE NOTICE OF SUCH CHANGES.

Renishaw plc. Registered in England and Wales. Company no: 1106260. Registered office: New Mills, Wotton-under-Edge, Glos, GL12 8JR, UK.

Part no.: H-5687-8504-05-A

Issued: 09.2022