

## RKL partial arc



This page is intentionally left blank.

## Contents

Introduction . . . . .	4
Legal notices . . . . .	6
Storage and handling . . . . .	8
RKL partial arc installation drawing . . . . .	10
VIONiC readhead installation drawing . . . . .	11
TONiC readhead installation drawing . . . . .	12
QUANTiC readhead installation drawing . . . . .	13
ATOM readhead installation drawing . . . . .	14
ATOM DX readhead installation drawing . . . . .	15
RESOLUTE readhead installation drawing . . . . .	16
RKL partial arc scale specifications . . . . .	17
Calculating required scale length . . . . .	18
RKL partial arc: Installation methods . . . . .	19
Method 1: Without end clamps . . . . .	20
Preparing the scale . . . . .	21
Preparing the substrate . . . . .	21
Installing the scale (RKL lengths ≥ 80 mm) . . . . .	21
Installing the scale (RKL lengths < 80 mm) . . . . .	23
Securing the ends of the scale . . . . .	24
Method 2: With end clamps . . . . .	25
Preparing the substrate . . . . .	26
Installing the scale (RKL lengths ≥ 80 mm) . . . . .	26
Installing the scale (RKL lengths < 80 mm) . . . . .	28
Installing the end clamps . . . . .	29
ATOM/ATOM DX readhead bracket dimensions . . . . .	30

# Introduction

RKL scale is suitable for wrapping around the external diameter of drums, shafts or arcs due to its flexible nature.

The minimum radius depends upon the chosen readhead:

	RKL scale type			
	RKLC20-S	RKLC40-S	RKLF40-S	RKLA30-S
<b>Compatible readheads</b>	VIONiC™ and TONiC™	QUANTiC™	ATOM™ and ATOM DX™	RESOLUTE™
<b>Pitch</b>	20 µm	40 µm	40 µm	30 µm
<b>Minimum arc radius</b>	30 mm	26 mm	26 mm	50 mm

For smaller radius requirements, contact your local Renishaw representative.

The recommended installation process for partial arc applications varies depending on the radius of the arc:

Radius	Installation method
≥ 26 mm	See <a href="#">'Method 1: Without end clamps'</a> on page 20
≥ 75 mm	See <a href="#">'Method 2: With end clamps'</a> on page 25

This installation guide covers our tested and recommended methods for installing arc scales.

If using alternative clamping methods:

- The end clamps **must** stop the scale from peeling up at either end of the readable scale
- The end clamps **must** either master the scale to the substrate or allow it to move freely to prevent buckling
- The end clamps **must not** clash with the readhead

This installation guide does not cover:

- Ultra-High Vacuum (UHV) systems
- Extended Temperature Range (ETR) systems (where the minimum operating temperature is less than 0 °C)
- The use of customer selectable reference magnets (with RKLC20-S or RKLC40-S scale)
- The use of limit magnets
- Internal diameters
- Rotations  $\geq 360^\circ$

For information on installing and calibrating the readhead refer to the relevant installation guide. These can be downloaded from our website at [www.renishaw.com/encoderinstallationguides](http://www.renishaw.com/encoderinstallationguides) and are also available from your local Renishaw representative.

## Legal notices

### Patents

Features of Renishaw's encoder systems and similar products are the subjects of the following patents and patent applications:

CN1314511      EP1469969      EP2390045      JP5002559      US8987633  
US8466943

### Terms and conditions and warranty

Unless you and Renishaw have agreed and signed a separate written agreement, the equipment and/or software are sold subject to the Renishaw Standard Terms and Conditions supplied with such equipment and/or software, or available on request from your local Renishaw office.

Renishaw warrants its equipment and software for a limited period (as set out in the Standard Terms and Conditions), provided that they are installed and used exactly as defined in associated Renishaw documentation. You should consult these Standard Terms and Conditions to find out the full details of your warranty.

Equipment and/or software purchased by you from a third-party supplier is subject to separate terms and conditions supplied with such equipment and/or software. You should contact your third-party supplier for details.

### Declaration of Conformity

Renishaw plc hereby declares that all RKL compatible readheads are in compliance with the essential requirements and other relevant provisions of:

- the applicable EU directives
- the relevant statutory instruments under UK law



The full text of the declaration of conformity is available at: [www.renishaw.com/productcompliance](http://www.renishaw.com/productcompliance).

### Compliance

#### Federal Code Of Regulation (CFR) FCC Part 15 – RADIO FREQUENCY DEVICES

##### 47 CFR Section 15.19

This device complies with part 15 of the FCC Rules. Operation is subject to the following two conditions: (1) This device may not cause harmful interference, and (2) this device must accept any interference received, including interference that may cause undesired operation.

##### 47 CFR Section 15.21

The user is cautioned that any changes or modifications not expressly approved by Renishaw plc or authorised representative could void the user's authority to operate the equipment.

##### 47 CFR Section 15.105

This equipment has been tested and found to comply with the limits for a Class A digital device, pursuant to part 15 of the FCC Rules. These limits are designed to provide reasonable protection against harmful interference when the equipment is operated in a commercial environment.

This equipment generates, uses, and can radiate radio frequency energy and, if not installed and used in accordance with the instruction manual, may cause harmful interference to radio communications. Operation of this equipment in a residential area is likely to cause harmful interference in which case the user will be required to correct the interference at his own expense.

##### 47 CFR Section 15.27

This unit was tested with shielded cables on the peripheral devices. Shielded cables must be used with the unit to ensure compliance.

## Supplier's Declaration of Conformity

### 47 CFR § 2.1077 Compliance Information

**Unique Identifiers:** ATOM, ATOM DX, QUANTiC, RESOLUTE, TONiC, VIONiC

#### Responsible Party - U.S. Contact Information

Renishaw Inc.  
 1001 Wesemann Drive  
 West Dundee  
 Illinois  
 IL 60118  
 United States  
 Telephone number: +1 847 286 9953  
 Email: [usa@renishaw.com](mailto:usa@renishaw.com)

### ICES-001 — Industrial, Scientific and Medical (ISM) Equipment (Canada)

This ISM device complies with Canadian ICES-001.

Cet appareil ISM est conforme à la norme ICES-001 du Canada.

### Intended use

The RKL compatible readheads are designed to measure position and provide that information to a drive or controller in applications requiring motion control. They must be installed, operated, and maintained as specified in Renishaw documentation and in accordance with the Standard Terms and Conditions of the Warranty and all other relevant legal requirements.

### Further information

Further information relating to the Renishaw encoder products can be found at [www.renishaw.com/opticalencoders](http://www.renishaw.com/opticalencoders) or by contacting your local Renishaw representative.

## Packaging

The packaging of our products contains the following materials and can be recycled.

Packing component	Material	ISO 11469	Recycling guidance
Outer box	Cardboard	Not applicable	Recyclable
	Polypropylene	PP	Recyclable
Inserts	Low density polyethylene foam	LDPE	Recyclable
	Cardboard	Not applicable	Recyclable
Bags	High density polyethylene bag	HDPE	Recyclable
	Metalised polyethylene	PE	Recyclable

## REACH regulation

Information required by Article 33(1) of Regulation (EC) No. 1907/2006 ("REACH") relating to products containing substances of very high concern (SVHCs) is available at [www.renishaw.com/REACH](http://www.renishaw.com/REACH).

## Disposal of waste electrical and electronic equipment



The use of this symbol on Renishaw products and/or accompanying documentation indicates that the product should not be mixed with general household waste upon disposal. It is the responsibility of the end user to dispose of this product at a designated collection point for waste electrical and electronic equipment (WEEE) to enable reuse or recycling. Correct disposal of this product will help to save valuable resources and prevent potential negative effects on the environment. For more information, contact your local waste disposal service or Renishaw distributor.

# Storage and handling

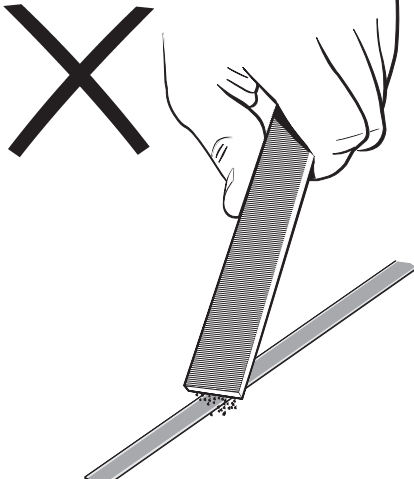
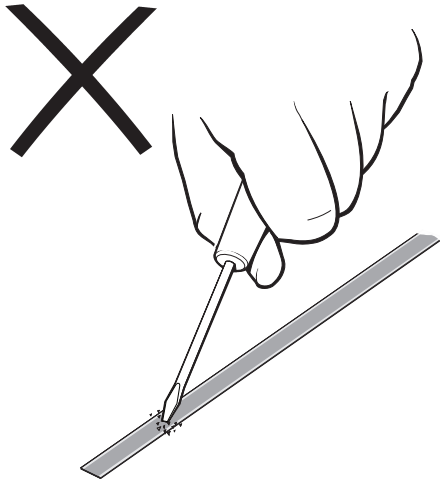
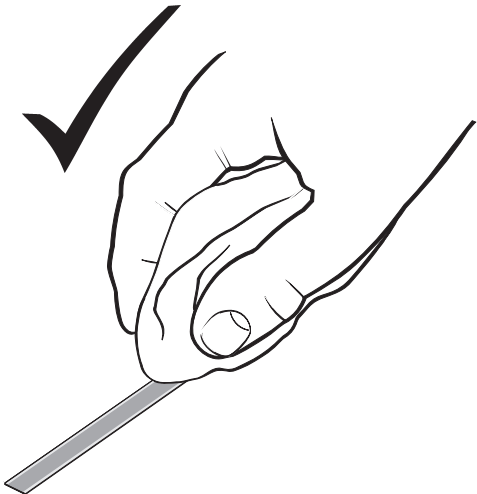

## Minimum bend radius

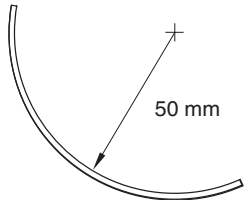

**NOTE:** During storage ensure self-adhesive tape is on outside of bend.

## Scale and readhead

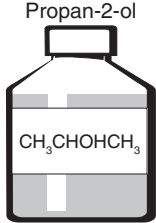
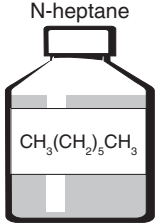

## Readhead only

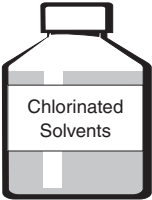
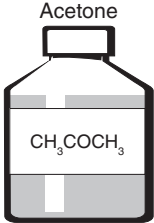



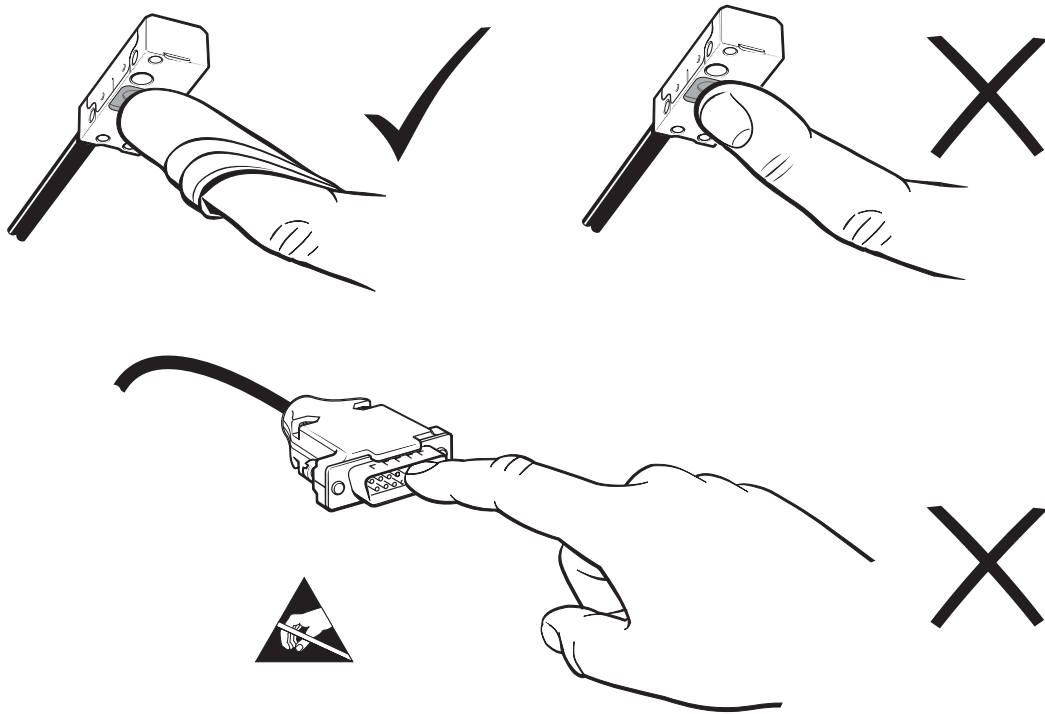

## Temperature

Storage	
ATOM, ATOM DX, QUANTiC and VIONiC readheads	-20 °C to +70 °C
RKL scale and RESOLUTE readheads	-20 °C to +80 °C

Operating	
System	0 °C to +70 °C

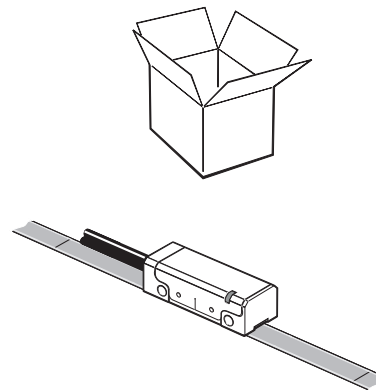

## Humidity

95% relative humidity (non-condensing) to IEC 60068-2-78

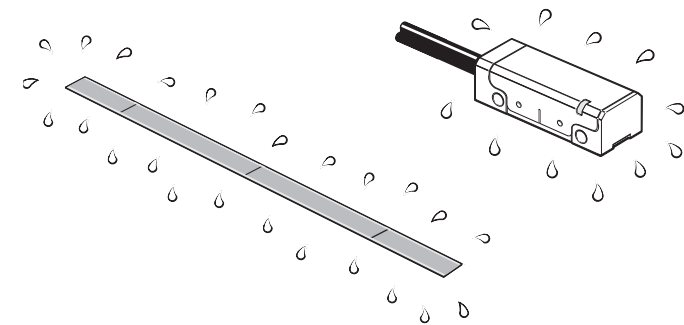

# RKL partial arc installation drawing (applicable for all compatible readheads)

Dimensions and tolerances in mm

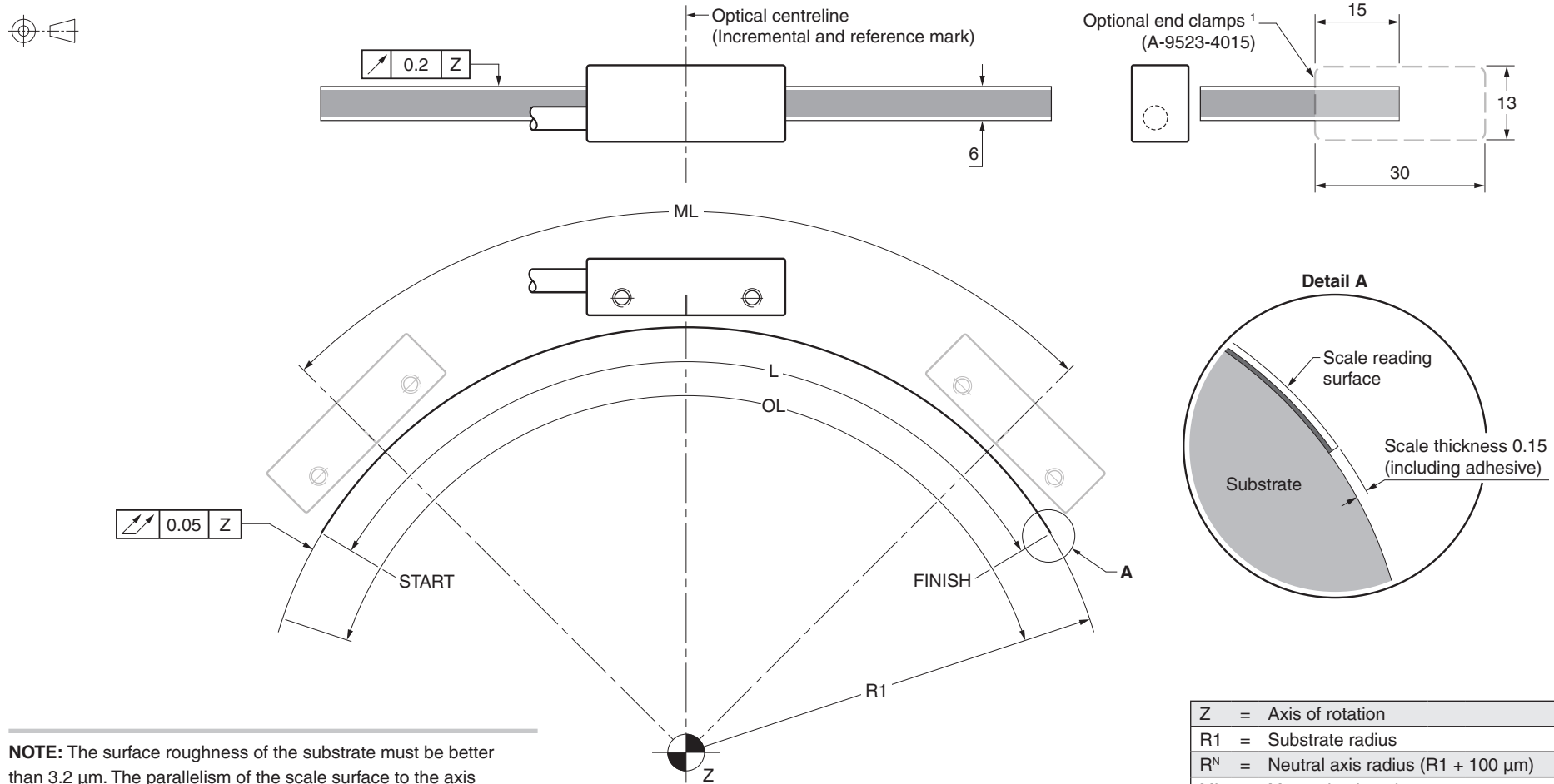

**NOTE:** The surface roughness of the substrate must be better than 3.2 µm. The parallelism of the scale surface to the axis guideway (readhead rideheight variation) must be within 0.05 mm.

<sup>1</sup> When not using end clamps, the scale ends must be secured using an alternative method (see 'Method 1: Without end clamps' on page 20).  
<sup>2</sup> When calculating scale length, the first reference mark is 50 mm from scale end.  
<sup>3</sup> For RESOLUTE systems: To ensure readhead does not clash with the end clamps, L = ML + 66 and OL = ML + 96.

Z	=	Axis of rotation
R1	=	Substrate radius
R <sup>N</sup>	=	Neutral axis radius (R1 + 100 µm)
ML	=	Measuring length
L	=	Scale length <sup>2</sup>
	with end clamps	L = ML + 40 <sup>3</sup>
	without end clamps	L = ML + 20
OL	=	Overall length
	with end clamps	OL = ML + 70 <sup>3</sup>

# VIONiC readhead installation drawing

Dimensions and tolerances in mm

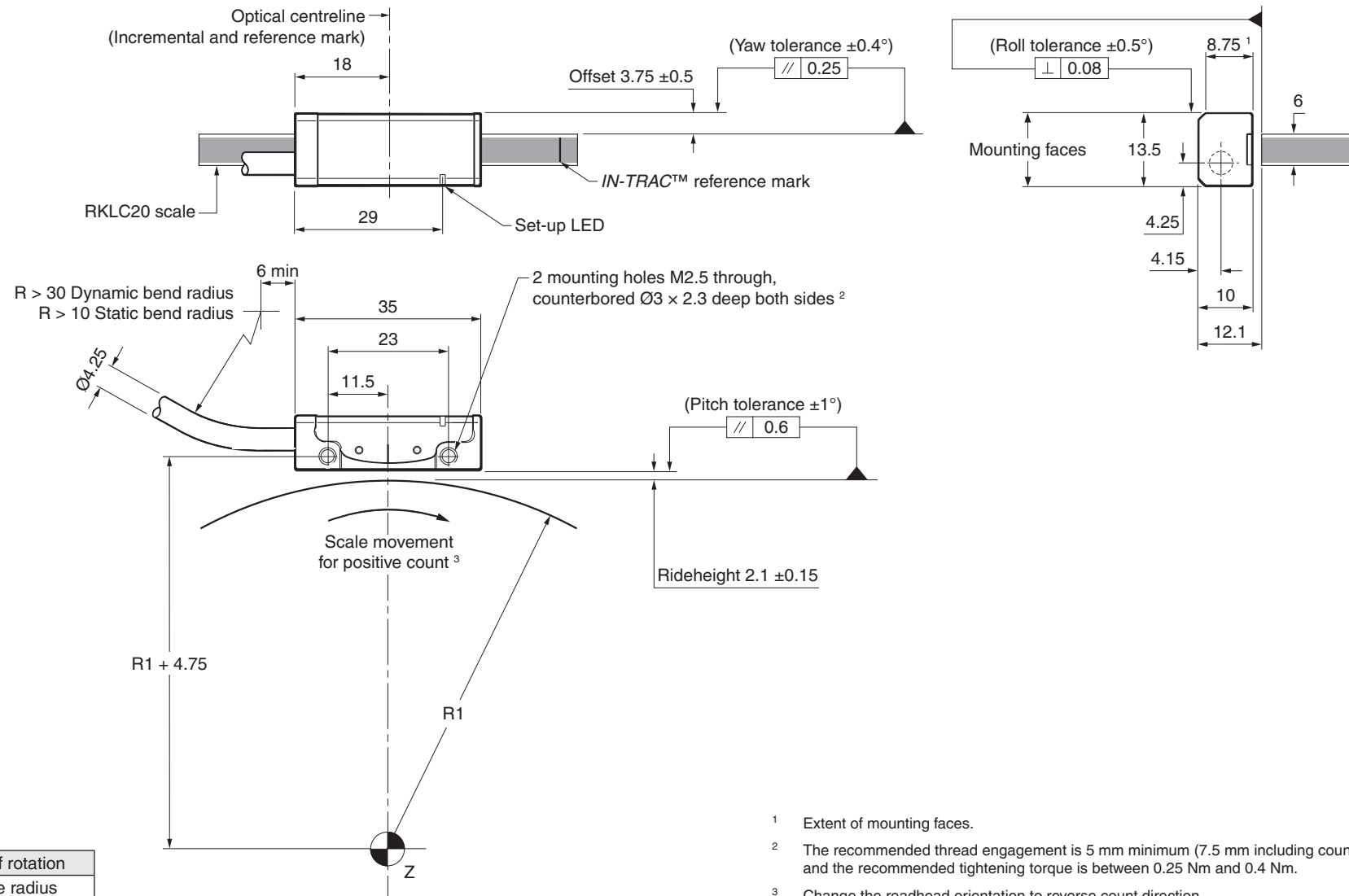

# TONiC readhead installation drawing

Dimensions and tolerances in mm

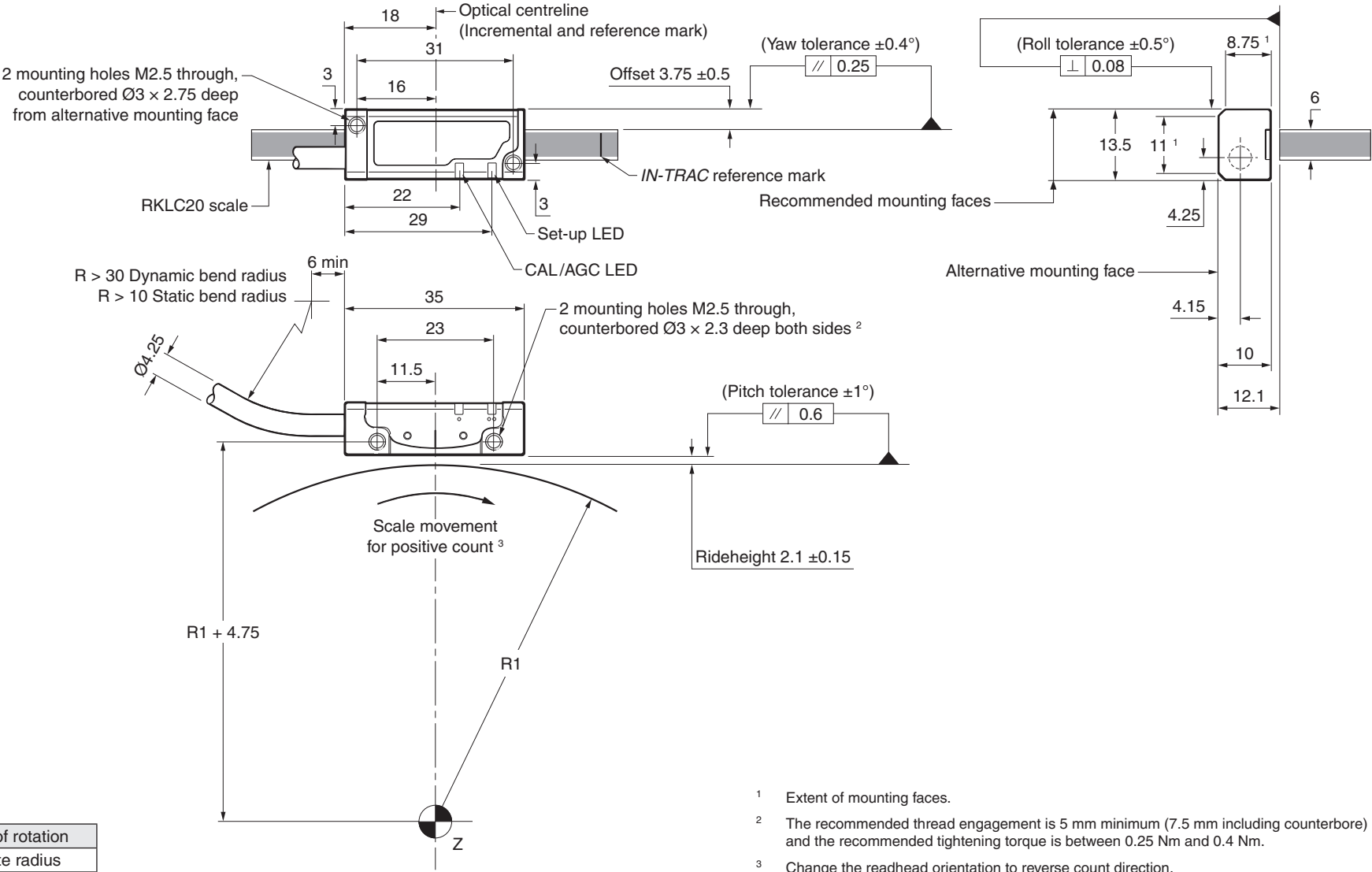

Z	= Centre of rotation
R1	= Substrate radius

- <sup>1</sup> Extent of mounting faces.
- <sup>2</sup> The recommended thread engagement is 5 mm minimum (7.5 mm including counterbore) and the recommended tightening torque is between 0.25 Nm and 0.4 Nm.
- <sup>3</sup> Change the readhead orientation to reverse count direction.

# QUANTiC readhead installation drawing

Dimensions and tolerances in mm

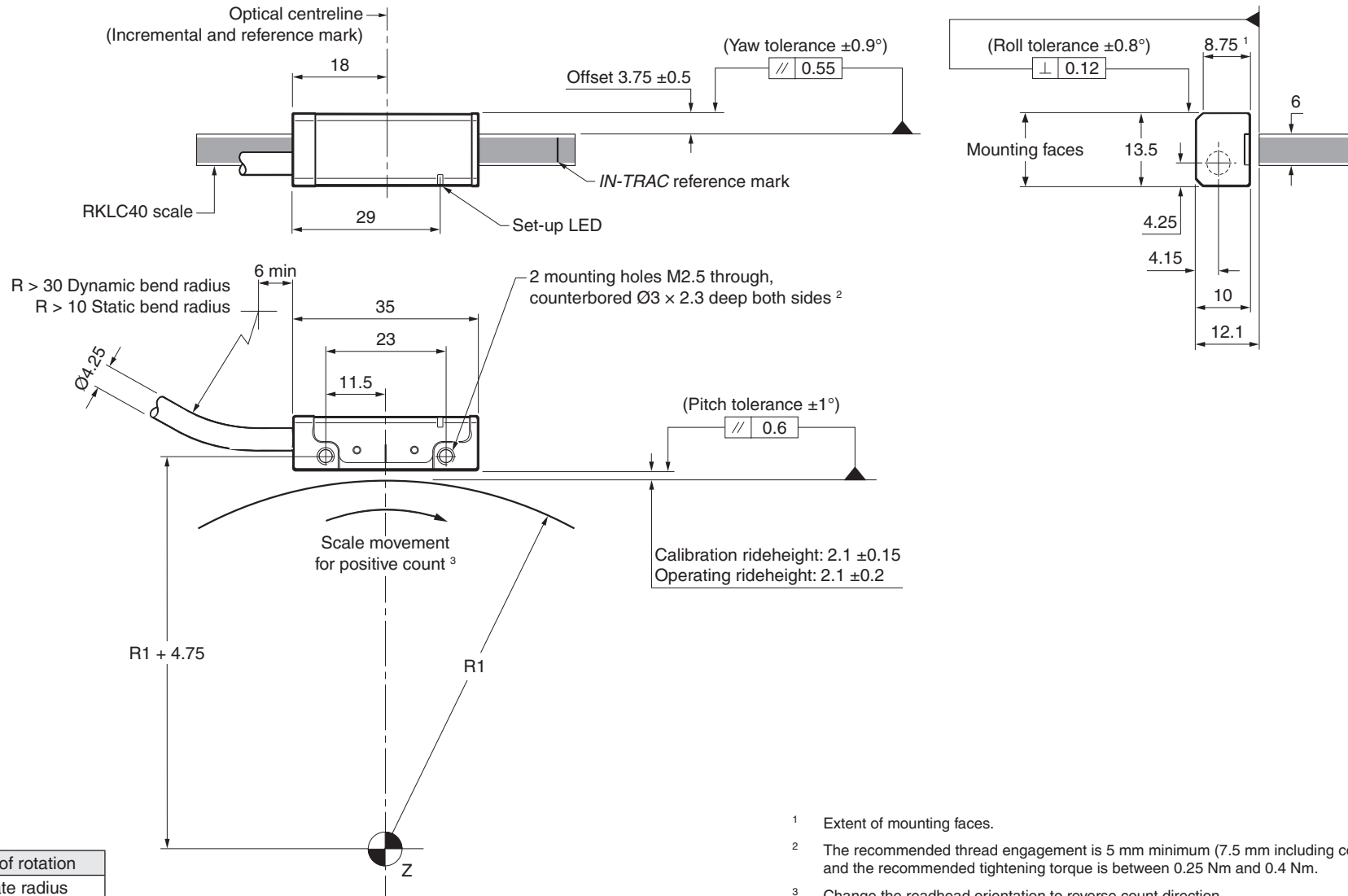

- <sup>1</sup> Extent of mounting faces.
- <sup>2</sup> The recommended thread engagement is 5 mm minimum (7.5 mm including counterbore) and the recommended tightening torque is between 0.25 Nm and 0.4 Nm.
- <sup>3</sup> Change the readhead orientation to reverse count direction.

# ATOM readhead installation drawing

Dimensions and tolerances in mm

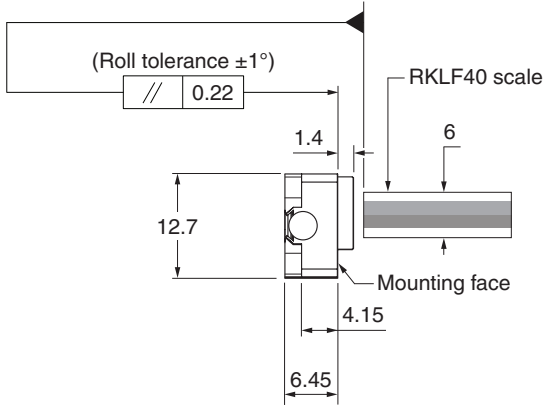
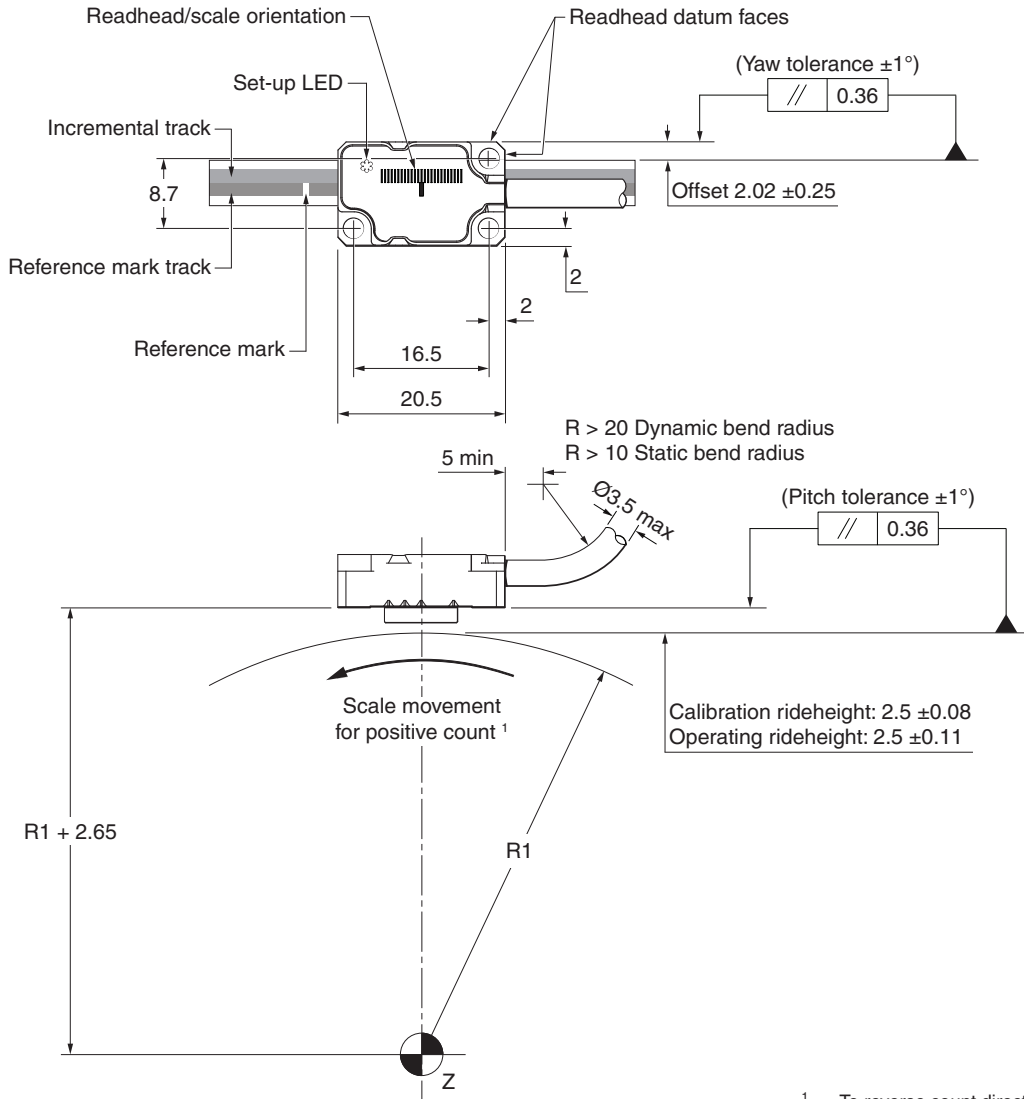

Z	= Centre of rotation
R1	= Substrate radius

<sup>1</sup> To reverse count direction both the readhead and the scale orientation must be changed.

# ATOM DX readhead installation drawing

Dimensions and tolerances in mm

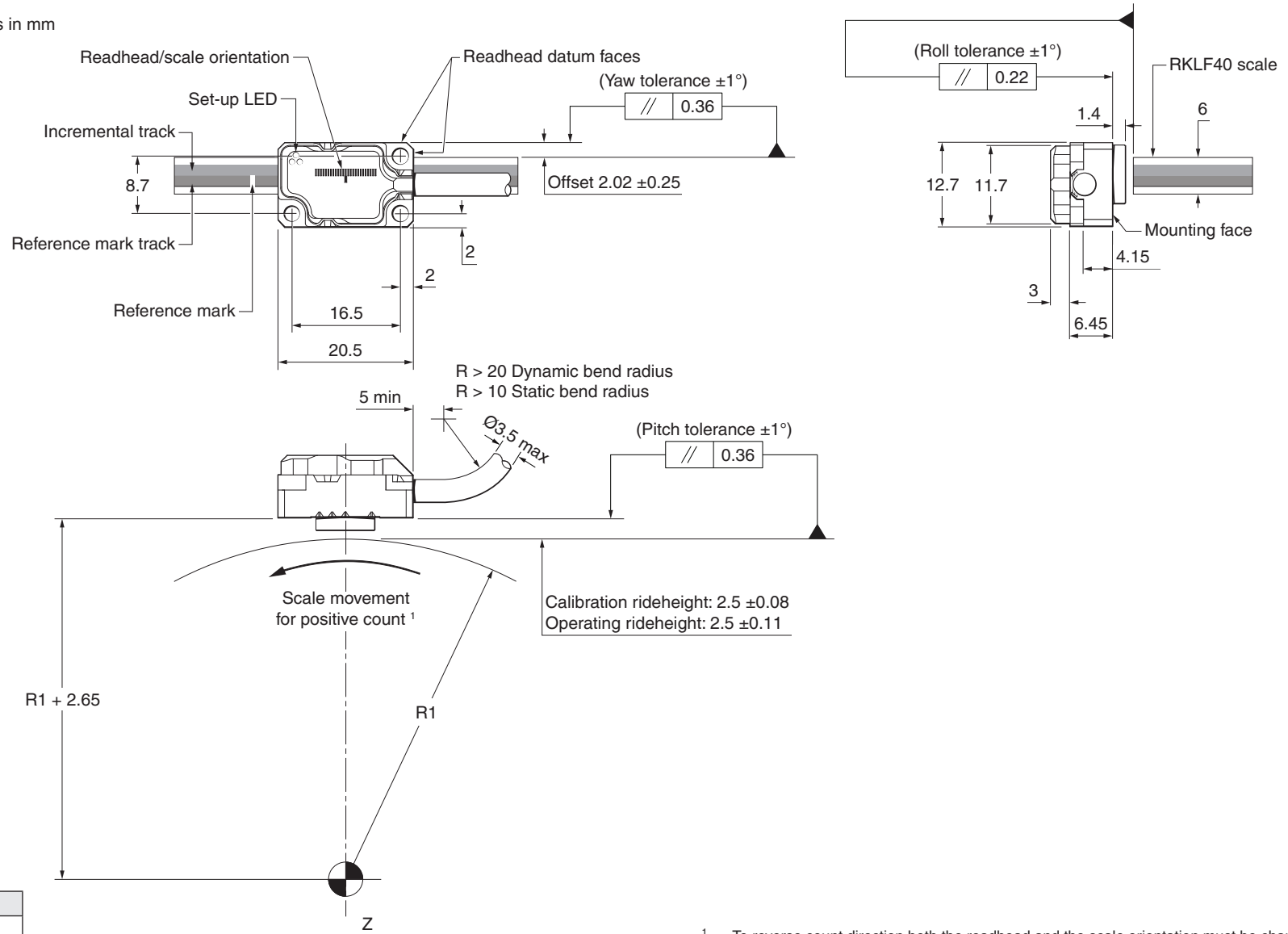

Z = Centre of rotation  
R1 = Substrate radius

<sup>1</sup> To reverse count direction both the readhead and the scale orientation must be changed.

# RESOLUTE readhead installation drawing

Dimensions and tolerances in mm

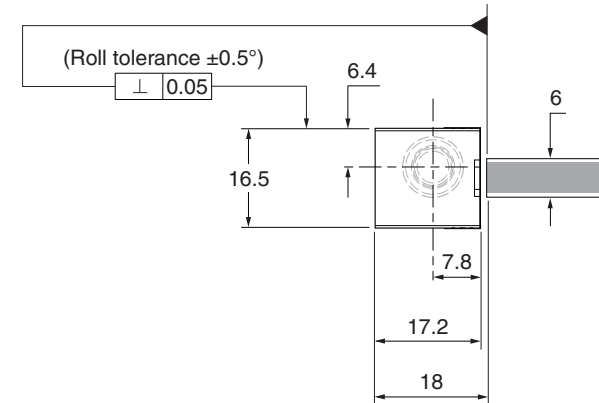
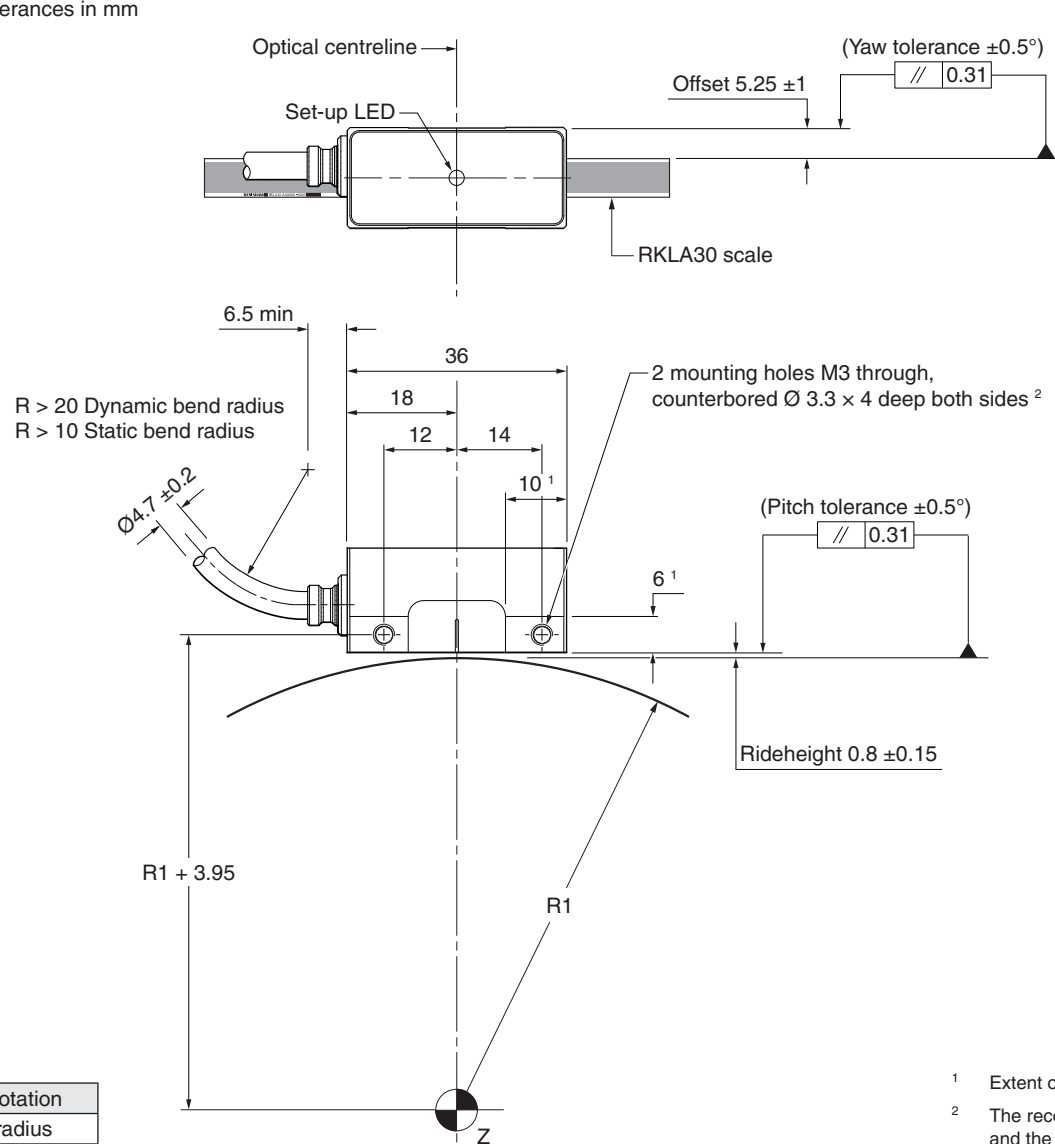

## Orientation of scale determines count direction



←  
Moving scale increases  
count direction

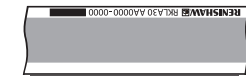

→  
Moving scale increases  
count direction

**NOTE:** Reversing readhead orientation  
has no effect on the count direction

Z = Centre of rotation  
R1 = Substrate radius

- <sup>1</sup> Extent of mounting faces.
- <sup>2</sup> The recommended thread engagement is 5 mm minimum (8 mm including counterbore) and the recommended tightening torque is between 0.5 Nm and 0.7 Nm.



## RKL partial arc scale specifications

	Incremental			Absolute
	RKLC20-S	RKLC40-S	RKLF40-S	RKLA30-S
<b>Compatible readheads</b>	VIONiC and TONiC	QUANTiC	ATOM and ATOM DX <sup>1</sup>	RESOLUTE
<b>Form (H × W)</b>	0.15 mm × 6 mm (including adhesive)			
<b>Pitch</b>	20 μm	40 μm	40 μm	30 μm
<b>Accuracy (at 20 °C) (based on neutral axis)</b>	±5 μm/m	±15 μm/m	±15 μm/m	±5 μm/m (including slope and linearity)
<b>Linearity (at 20 °C) (based on neutral axis)</b>	±2.5 μm/m	±3 μm/m	±3 μm/m	-
<b>Supplied length</b>	20 mm to 20 m (> 20 m available on request)		20 mm to 10 m (> 10 m available on request)	20 mm to 21 m
<b>Material</b>	Hardened and tempered stainless steel			
<b>Mass</b>	4.6 g/m			
<b>Coefficient of thermal expansion (at 20 °C)</b>	10.1 ±0.2 μm/m/°C			
<b>Temperature</b>	Storage	-20 °C to +80 °C		
	Operating <sup>2</sup>	0 °C to +70 °C		
	Installation	+10 °C to +35 °C		
<b>Humidity</b>	95% relative humidity (non-condensing) to IEC 60068-2-78			
<b>Shock</b>	Operating	500 m/s <sup>2</sup> , 11 ms, ½ sine, 3 axes		
<b>Vibration</b>	Operating	300 m/s <sup>2</sup> maximum @ 55 to 2000 Hz, 3 axes		
<b>Recommended end fixing</b>	R ≥ 75 mm	Epoxy mounted end clamps (A-9523-4015)		
	R ≥ 26 mm	Approved epoxy adhesive (A-9531-0342)		
<b>Minimum arc radius <sup>3</sup></b>	30 mm	26 mm	26 mm	50 mm

<sup>1</sup> 40 μm ATOM and ATOM DX variants only.

<sup>2</sup> To limit maximum tension in the scale  $(CTE_{\text{substrate}} - CTE_{\text{scale}}) \times (T_{\text{use extreme}} - T_{\text{install}}) \leq 550 \mu\text{m/m}$  where  $CTE_{\text{scale}} = \sim 10.1 \mu\text{m/m/}^\circ\text{C}$ .

<sup>3</sup> For smaller radii contact your local Renishaw representative.

# Calculating required scale length

The required scale length depends upon the measuring length, chosen mounting method and readhead type.

## 1. Calculate the measuring length of scale for the arc being measured:

$$\begin{aligned} \text{Measuring length (ML)} &= \text{circumference of the substrate} \times \frac{\text{the angle of the arc being measured}}{\text{angle in a full circle}} \\ &= 2 \pi r \left( \frac{\text{the angle of the arc being measured}}{360^\circ} \right) \end{aligned}$$

## 2. Choose a mounting method:

The mounting method will depend upon the radius of the substrate and the available space.

**Radius:**

	Without end clamps (epoxy scale ends)	With end clamps
Radius < 75 mm	✓	✗
Radius ≥ 75 mm	✓	✓

**Available space:**

Ensure there is space for end clamps when choosing the mounting method (see 'RKL partial arc installation drawing' on page 10).

	Overall system length	
	TONiC, VIONiC, QUANTiC, ATOM and ATOM DX	RESOLUTE
Without end clamps	Measuring length (ML) + 20	
With end clamps	Measuring length (ML) + 70	Measuring length (ML) + 96 <sup>1</sup>

## 3. Calculate the required scale length:

	Required scale length	
	TONiC, VIONiC, QUANTiC, ATOM and ATOM DX <sup>2</sup>	RESOLUTE
Without end clamps	Measuring length (ML) + 20	
With end clamps	Measuring length (ML) + 40	Measuring length (ML) + 66 <sup>1</sup>

<sup>1</sup> To ensure the RESOLUTE readhead does not clash with the end clamps.

<sup>2</sup> The required reference mark location should be taken into account when calculating the required scale length. For L ≥ 100 mm the reference marks are spaced every 50 mm with the first reference mark 50 mm from the scale end. For L < 100 mm a single reference mark is at the mid-point of the scale length.

## RKL partial arc: Installation methods

RKL partial arc scale application depends upon radius and scale length. The following flow chart is a guide to choosing the appropriate installation method.

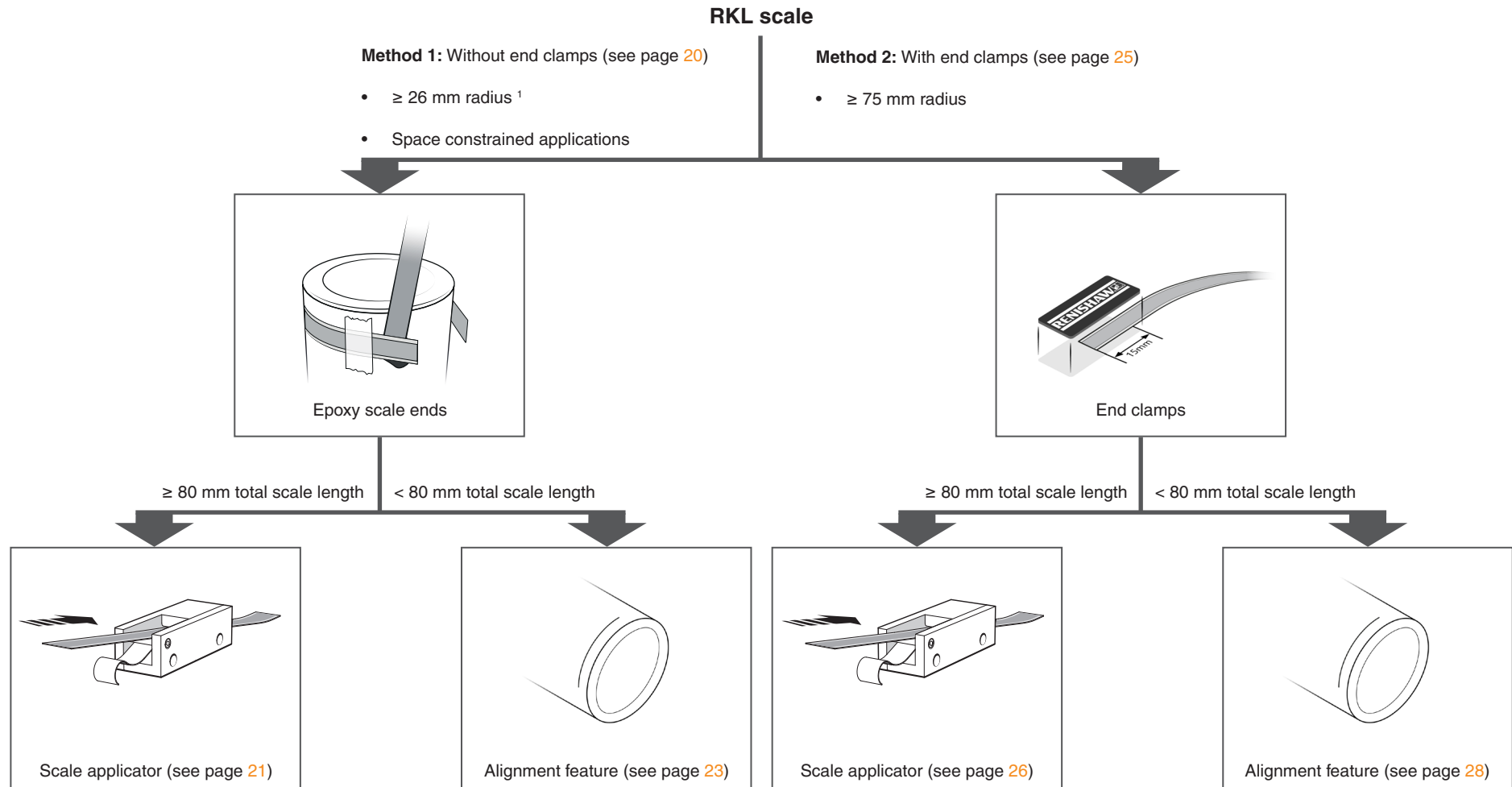

<sup>1</sup> Minimum radius depends upon the chosen readhead (see page 4 for details).

# Method 1: Without end clamps

## Suitable for:

- Small radius partial arc applications (26 mm to 75 mm)
- Partial arc radii  $\geq 75$  mm without space for end clamps (see 'RKL partial arc installation drawing' on page 10)

## Required tools:

- Scalpel
- Suitable spatula (for adhesive application)
- Lint-free cloth
- RKL polyester retaining tape <sup>1</sup> (A-6547-1949)
- Appropriate scale applicator (for scale lengths  $\geq 80$  mm)

RKL scale type	Compatible readheads	Applicator mounting	Scale applicator part number	Readhead bracket <sup>2</sup>
RKLC	VIONiC, TONiC and QUANTiC	Side	A-6547-1912	-
	TONiC	Top	A-6547-1915	-
RKLF	ATOM and ATOM DX	Side	A-6547-1943	'L' bracket (A-9402-0037)
		Top	A-6547-1939	
		Slim side	A-6547-1947	Side mount (A-9401-0103)
RKLA	RESOLUTE	Side	A-6547-1918	-

## Required parts:

- Appropriate length of RKL scale (see 'Calculating required scale length' on page 18)
- RGG-2 two part epoxy adhesive (A-9531-0342)
- Appropriate cleaning solvents (see 'Storage and handling' on page 8)

## Optional parts:

- Renishaw scale wipes (A-9523-4040)

<sup>1</sup> Retaining tape must be 6 mm  $\pm$ 0.5 mm wide and have a peel adhesion of approximately 35 N/mm in order to retain the scale. 66 m length of RKL polyester retaining tape; A-6547-1949.

<sup>2</sup> See page 30 for drawings of the ATOM / ATOM DX mounting brackets.

## Preparing the scale

1. Cut the backing paper and self-adhesive tape 10 mm from each end of the scale using a scalpel or similar.

---

**NOTE:** The end 10 mm of scale will not be readable by the readhead.

---

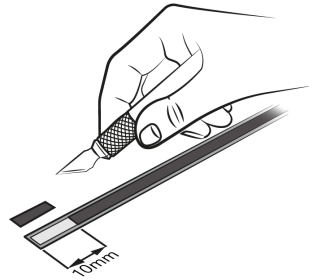

2. Using a flat blade, remove the backing paper and self-adhesive tape from both ends of the scale.

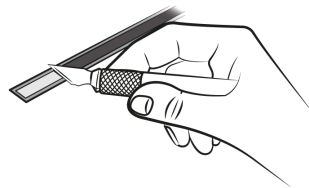

3. Using the recommended solvents (see 'Storage and handling' on page 8) thoroughly clean the end 10 mm of scale to remove any residual adhesive.

## Preparing the substrate

1. Mark out the 'START' point for the scale on the axis substrate (see 'RKL partial arc installation drawing' on page 10).
2. Thoroughly clean and degrease the substrate using the recommended solvents (see 'Storage and handling' on page 8). Allow substrate to dry before applying scale.

## Installing the scale (RKL lengths $\geq 80$ mm)

1. Position the scale applicator to ensure the scale comes out of the applicator straight and tangentially touches the substrate. This can be done by offsetting the applicator from the readhead position by 45 to 50 mm or by angling the applicator.

### Offset applicator

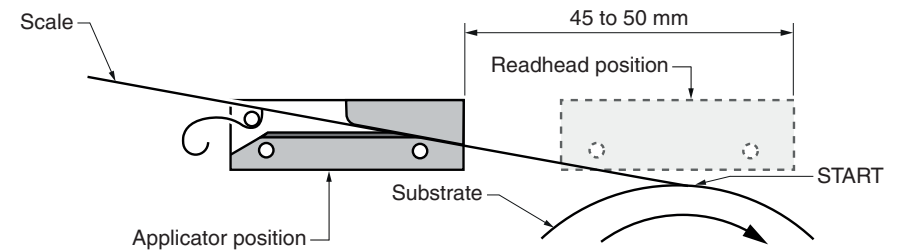

### Angled applicator

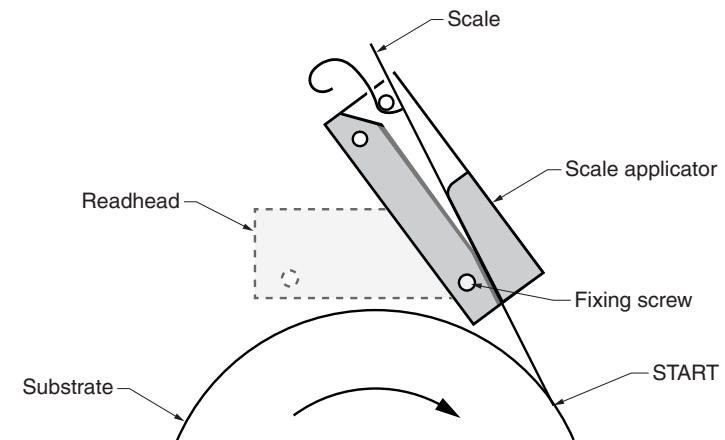

2. Mount the scale applicator in the chosen location ensuring it is securely mounted.
3. Rotate the axis to scale 'START' position, leaving enough room for the scale to be inserted through the scale applicator.
4. Begin to remove the backing paper from the scale and insert scale into the applicator up to the 'START' point. Ensure backing paper is routed under the splitter screw.

---

**NOTE:** Ensure correct orientation of the scale.

For RKLf: See '[ATOM readhead installation drawing](#)' on page 14  
or '[ATOM DX readhead installation drawing](#)' on page 15.

For RKL A: See '[RESOLUTE readhead installation drawing](#)' on page 16.

---

**RKLC scale applicator shown**

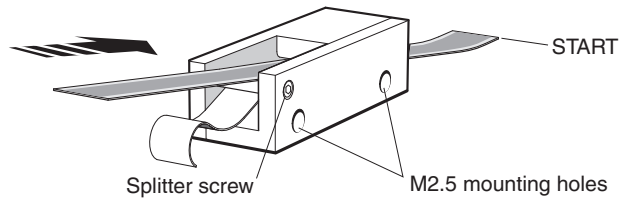

5. Ensure that the end of the scale is in line with the 'START' position on the axis and apply finger pressure via a clean lint-free cloth to ensure that the scale adheres to the substrate.
6. Slowly and smoothly rotate the axis through the entire axis of travel, ensuring the backing paper is pulled manually from the scale and does not catch under the applicator.

7. During installation ensure that the scale is adhered to the substrate using light finger pressure via a clean lint-free cloth. As the scale is installed apply polyester retaining tape across the scale 10 mm away from the ends of the scale. The retaining tape holds the scale in place to ensure it does not lift before the ends are secured.

---

**NOTE:** Apply tape at both ends of the scale ensuring that it does not cover the ends where the adhesive has been removed.

---

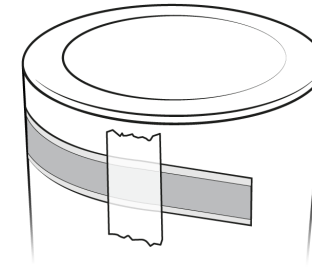

8. Secure the ends of the scale (see page 24).

## Installing the scale (RKL lengths < 80 mm)

For scale lengths of < 80 mm it is not practical to use a scale applicator, so the scale should be positioned against a ledge or alignment feature to minimise axial runout.

---

**NOTE:** The ledge or alignment feature must ensure readhead clearance.

---

1. Mark out the 'START' point for the scale (see '[RKL partial arc installation drawing](#)' on page 10) and alignment feature to align the scale in the correct location.

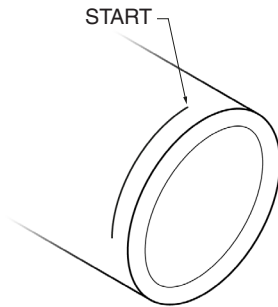

2. Remove the backing paper and carefully align the scale with the ledge or alignment feature.

---

**NOTE:** Ensure correct orientation of the scale.

For RKL: See '[ATOM readhead installation drawing](#)' on page 14  
or '[ATOM DX readhead installation drawing](#)' on page 15.

For RKL: See '[RESOLUTE readhead installation drawing](#)' on page 16.

---

3. Ensure that the scale is adhered to the substrate using light finger pressure via a clean lint-free cloth. As the scale is installed apply polyester retaining tape across the scale 10 mm away from the ends of the scale. The retaining tape holds the scale in place to ensure it does not lift before the ends are secured.

---

**NOTE:** Ensure the retaining tape does not cover the scale ends where the adhesive has been removed.

---

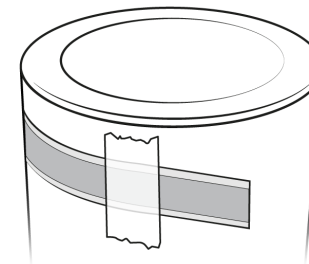

4. Secure the ends of the scale (see page 24).

## Securing the ends of the scale

Ensure the ends of the scale are secured immediately after scale installation to prevent the scale lifting.

1. Thoroughly mix up a sachet of RGG-2 two part epoxy adhesive and using a suitable spatula apply epoxy to the underside of the 10 mm section at the ends of the scale as shown below.

---

**NOTE:** Polyester retaining tape can be used to protect the readable scale surface.

---

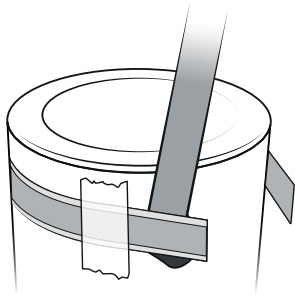

2. Firmly hold the ends of the scale in place whilst the epoxy cures. This can be done by:
  - Cutting two lengths of RKL polyester retaining tape at least 10 mm longer than the scale.
  - Starting near the middle of the length of scale, apply one of the lengths of retaining tape to the scale and wrap it around the circumference of the arc continuously maintaining tension in the tape as it is wrapped.

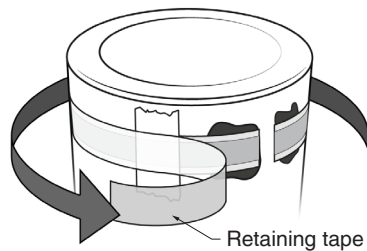

- If possible, starting at the scale end apply the other length of polyester retaining tape in the opposite direction. This results in both ends being secured against the substrate as the adhesive cures.

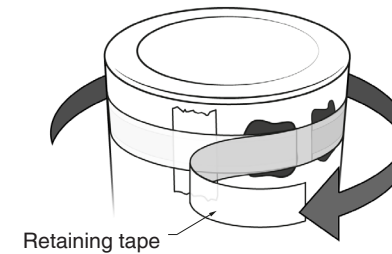

3. Remove any excess epoxy and leave to cure for a minimum of 24 hours at 20 °C.

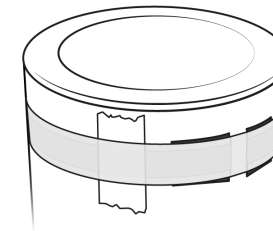

4. After 24 hours, remove all layers of RKL polyester retaining tape, if used.
5. Clean the scale using Renishaw scale wipes or a clean, dry, lint-free cloth.



## Method 2: With end clamps

### Suitable for:

- Large radius partial arc applications ( $\geq 75$  mm)
- Applications with space for end clamps (see 'RKL partial arc installation drawing' on page 10)

**NOTE:** If the application does not have space for end clamps, the end of the scale must be securely fixed to the substrate using an alternative method (see 'Method 1: Without end clamps' on page 20)

### Required tools:

- Suitable spatula (for adhesive application)
- Lint-free cloth
- Appropriate scale applicator (for scale lengths  $\geq 80$  mm)

RKL scale type	Compatible readheads	Applicator mounting	Scale applicator part number	Readhead bracket <sup>1</sup>
RKLC	VIONiC, TONiC and QUANTiC	Side	A-6547-1912	-
	TONiC	Top	A-6547-1915	-
RKLF	ATOM and ATOM DX	Side	A-6547-1943	'L' bracket (A-9402-0037)
		Top	A-6547-1939	
		Slim side	A-6547-1947	Side mount (A-9401-0103)
RKLA	RESOLUTE	Side	A-6547-1918	-

### Required parts:

- Appropriate length of RKL scale (see 'Calculating required scale length' on page 18)
- RGG-2 two part epoxy adhesive (A-9531-0342)
- RGC-F end clamp kit - epoxy mounted (A-9523-4015)
- Appropriate cleaning solvents (see 'Storage and handling' on page 8)

### Optional parts:

- Renishaw scale wipes (A-9523-4040)

<sup>1</sup> See page 30 for drawings of the ATOM / ATOM DX mounting brackets.

## Preparing the substrate

1. Mark out the 'START' point for the scale on the axis substrate (see 'RKL partial arc installation drawing' on page 10).
2. Thoroughly clean and degrease the substrate using the recommended solvents (see 'Storage and handling' on page 8). Allow substrate to dry before applying scale.

## Installing the scale (RKL lengths $\geq 80$ mm)

1. Position the scale applicator to ensure the scale comes out of the applicator straight and tangentially touches the substrate. This can be done by offsetting the applicator from the readhead position by 45 to 50 mm or by angling the applicator.

### Offset applicator

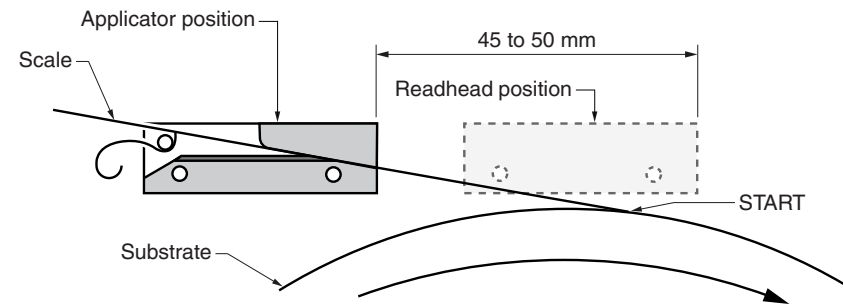

### Angled applicator

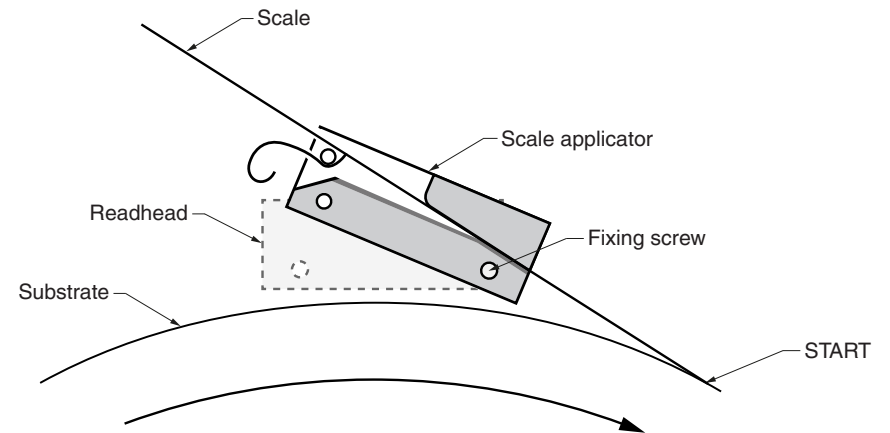

2. Mount the scale applicator in the chosen location ensuring it is securely mounted.
3. Rotate the axis to scale 'START' position, leaving enough room for the scale to be inserted through the scale applicator.
4. Begin to remove the backing paper from the scale and insert scale into the applicator up to the 'START' point. Ensure backing paper is routed under the splitter screw.

---

**NOTE:** Ensure correct orientation of the scale.

For RKLF: See '[ATOM readhead installation drawing](#)' on page 14  
or '[ATOM DX readhead installation drawing](#)' on page 15.

For RKLA: See '[RESOLUTE readhead installation drawing](#)' on page 16.

---

**RKLC scale applicator shown**

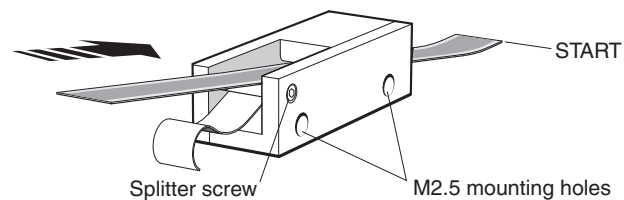

5. Ensure that the end of the scale is in line with the 'START' position on the axis and apply finger pressure via a clean lint-free cloth to ensure that the scale adheres to the substrate.
6. Slowly and smoothly rotate the axis through the entire axis of travel, ensuring the backing paper is pulled manually from the scale and does not catch under the applicator.
7. During installation ensure that the scale is adhered to the substrate using light finger pressure via a clean lint-free cloth.
8. Remove the applicator carefully. Apply firm finger pressure via a clean lint-free cloth along the length of the scale after application to ensure complete adhesion.
9. Clean the scale using Renishaw scale wipes or a clean, dry, lint-free cloth.
10. Fit end clamps (see '[Installing the end clamps](#)' on page 29).

## Installing the scale (RKL lengths < 80 mm)

For scale lengths of < 80 mm it is not practical to use a scale applicator, so the scale should be positioned against a ledge or alignment feature to minimise axial runout.

---

**NOTE:** The ledge or alignment feature must ensure readhead clearance and allow for end clamps to be fitted.

---

1. Mark out the 'START' point for the scale (see '[RKL partial arc installation drawing](#)' on page 10) and alignment feature to align the scale in the correct location.

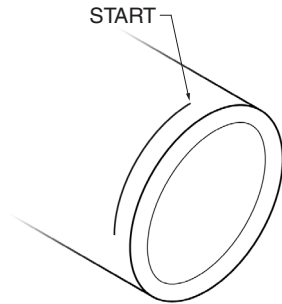

2. Slowly and smoothly position the scale around the axis of travel, ensuring the backing paper is pulled manually from the scale.

---

**NOTE:** Ensure correct orientation of the scale.

For RKLf: See '[ATOM readhead installation drawing](#)' on page 14  
or '[ATOM DX readhead installation drawing](#)' on page 15.

For RKL A: See '[RESOLUTE readhead installation drawing](#)' on page 16.

---

3. During installation ensure that the scale is adhered to the substrate using light finger pressure.
4. After application apply firm finger pressure via a clean lint-free cloth along the length of the scale to ensure complete adhesion.
5. Clean the scale using Renishaw scale wipes or a clean, dry, lint-free cloth.
6. Fit end clamps (see '[Installing the end clamps](#)' on page 29).

## Installing the end clamps

Ensure the end clamps are installed immediately after scale installation to prevent the scale lifting.

1. Clean the ends of the scale area where the end clamps are to be fitted using Renishaw scale wipes or one of the recommended solvents (see 'Storage and handling' on page 8).

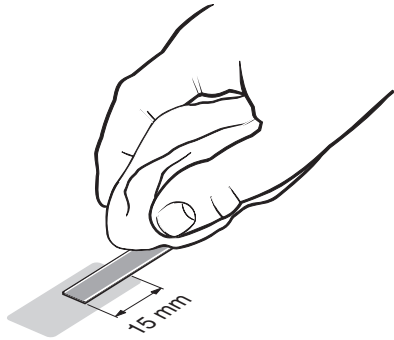

2. Thoroughly mix up a sachet of RGG-2 two part epoxy adhesive and apply a small amount to the underside of the end clamp.

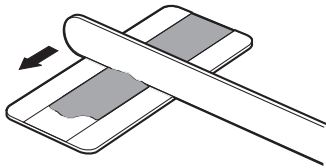

3. The end clamp features two small regions of contact adhesive. These temporarily hold the end clamp in position while the epoxy cures. Remove the backing tape from either side.

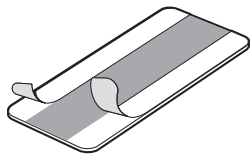

4. Immediately position the end clamp over the end of the scale and push down to ensure complete adhesion. Allow 24 hours at 20 °C for full cure.

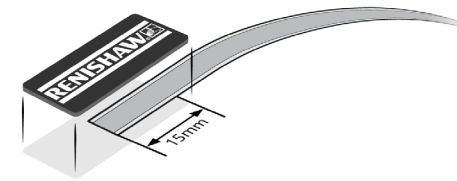

---

**CAUTION:** Ensure that excess epoxy is wiped away from scale as it may affect the readhead signal level.

---

# ATOM/ATOM DX readhead bracket dimensions

Dimensions and tolerances in mm



'L' mount bracket (A-9402-0037)

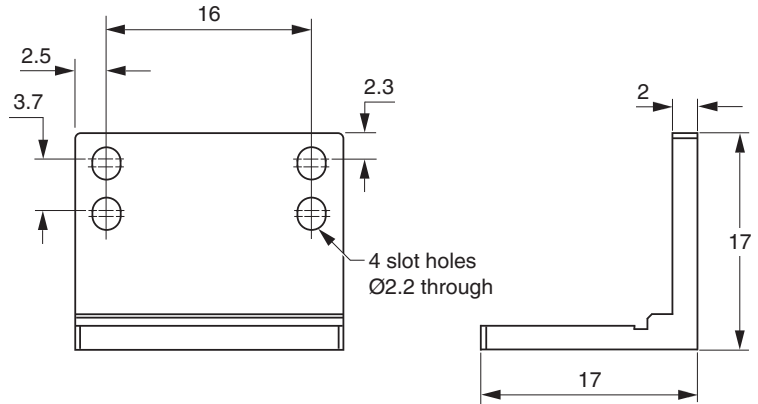
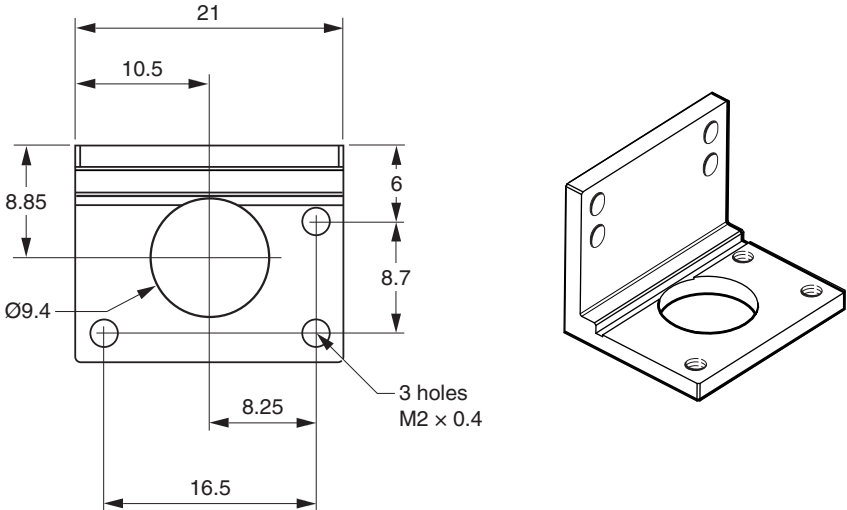

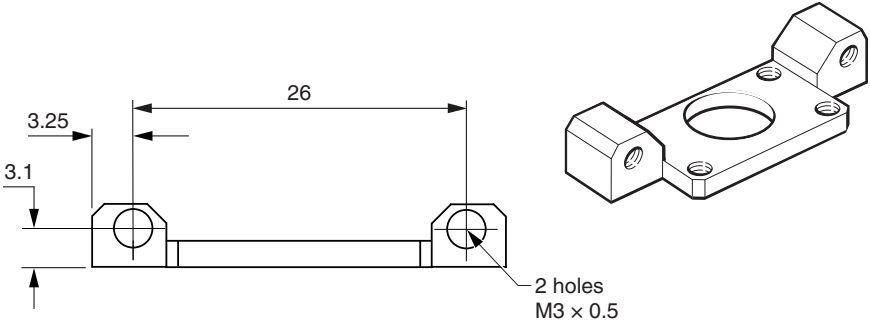
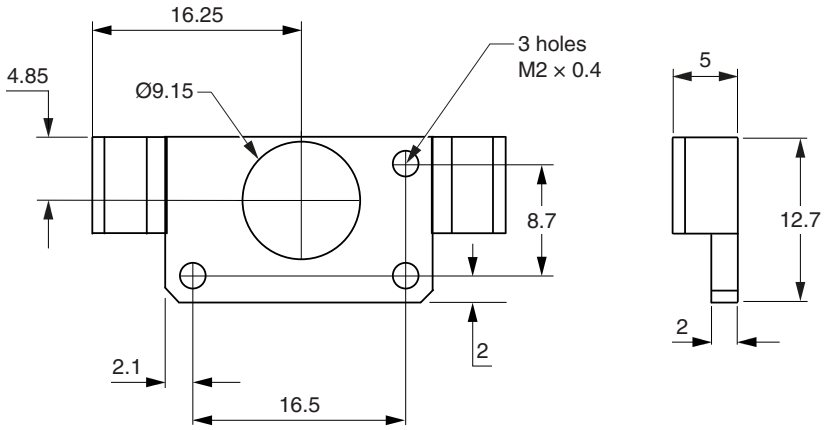

Side mount bracket (A-9401-0103)



[www.renishaw.com/contact](http://www.renishaw.com/contact)

 #renishaw

 +44 (0) 1453 524524  [uk@renishaw.com](mailto:uk@renishaw.com)

© 2020–2022 Renishaw plc. All rights reserved. This document may not be copied or reproduced in whole or in part, or transferred to any other media or language by any means, without the prior written permission of Renishaw.  
RENISHAW® and the probe symbol are registered trade marks of Renishaw plc. Renishaw product names, designations and the mark 'apply innovation' are trade marks of Renishaw plc or its subsidiaries. Other brand, product or company names are trade marks of their respective owners. Renishaw plc. Registered in England and Wales. Company no: 1106260. Registered office: New Mills, Wotton-under-Edge, Glos, GL12 8JR, UK.

WHILE CONSIDERABLE EFFORT WAS MADE TO VERIFY THE ACCURACY OF THIS DOCUMENT AT PUBLICATION, ALL WARRANTIES, CONDITIONS, REPRESENTATIONS AND LIABILITY, HOWSOEVER ARISING, ARE EXCLUDED TO THE EXTENT PERMITTED BY LAW. RENISHAW RESERVES THE RIGHT TO MAKE CHANGES TO THIS DOCUMENT AND TO THE EQUIPMENT, AND/OR SOFTWARE AND THE SPECIFICATION DESCRIBED HEREIN WITHOUT OBLIGATION TO PROVIDE NOTICE OF SUCH CHANGES.

Part no.: M-6547-9168-03-B  
Issued: 12.2022