

RGH34 RGS40 linear encoder system

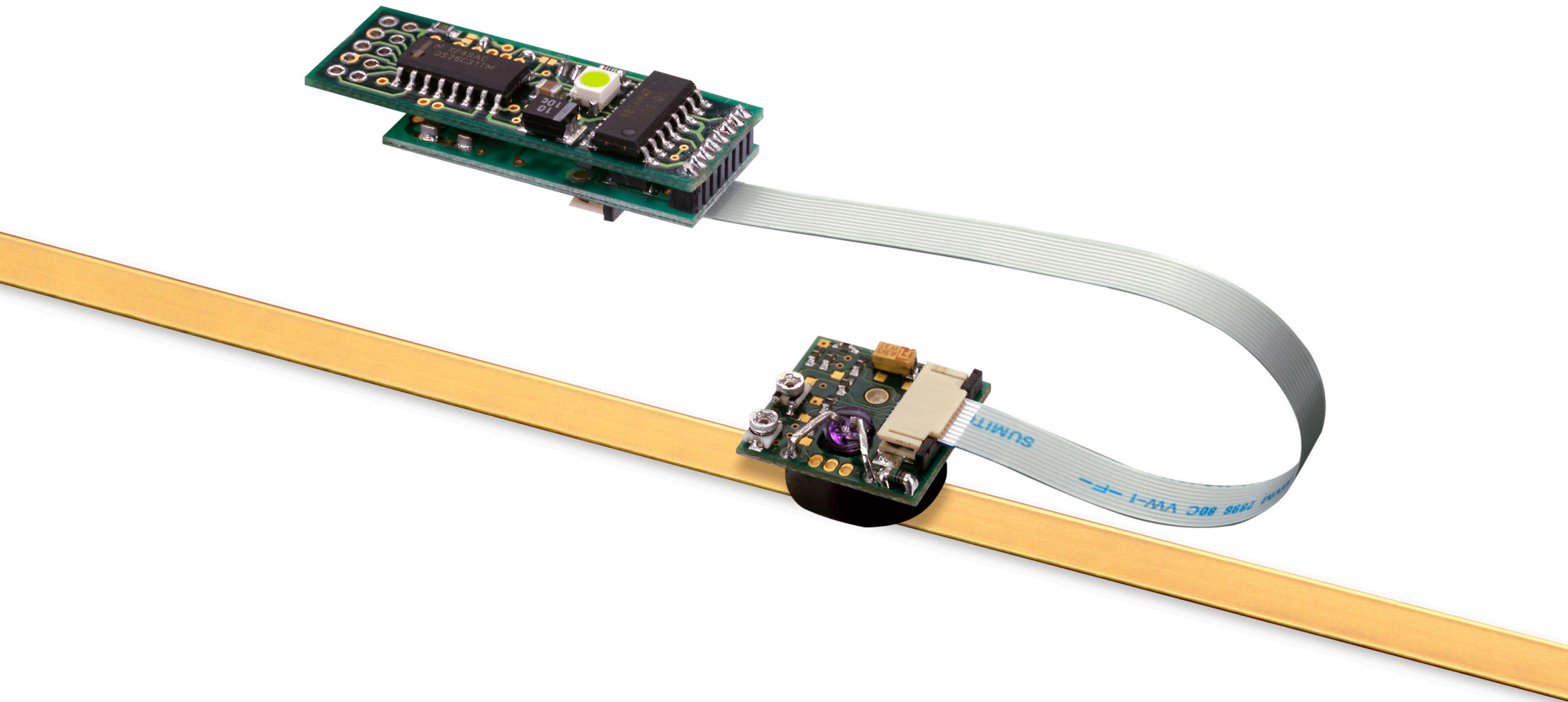

Contents

Product compliance	1
Storage and handling	2
RGH34 readhead installation drawing	3
RGI34 interface installation drawing	4
RGS40 scale installation drawing	5
Scale application	6
End clamps	6
Reference mark and limit switch actuator installation	6
Readhead mounting/installation	7
Readhead set-up	8
Reference mark set-up	8
Limit switch	9
Output signals	9
Speed	9
Electrical connections	10
Output specifications	11
General specifications	12
Scale specifications	12

Product compliance



The RGH34 and RGI34 have been designed as system components and to be compliant with EMC regulations for products of their type. Care must be taken with shielding and grounding arrangements to ensure EMC performance once installed. It is the system integrator's responsibility to implement, test and prove EMC compatibility for the whole machine. A copy of the EU Declaration of Conformity is available from our website at www.renishaw.com/productcompliance

Patents

Features of Renishaw's encoder systems and similar products are the subjects of the following patents and patent applications:

EP1147377 JP4571768 US6588333

Further information

Further information relating to the RGH34 encoder range can be found in the *RGH34 encoder system* Data sheet (Renishaw part no. L-9517-9728). This can be downloaded from our website at www.renishaw.com/opticalencoders and is also available from your local representative.

This document may not be copied or reproduced in whole or in part, transferred to any other media or language, by any means without the written prior permission of Renishaw. The publication of material within this document does not imply freedom from the patent rights of Renishaw plc.

Disclaimer

RENISHAW HAS MADE CONSIDERABLE EFFORTS TO ENSURE THE CONTENT OF THIS DOCUMENT IS CORRECT AT THE DATE OF PUBLICATION BUT MAKES NO WARRANTIES OR REPRESENTATIONS REGARDING THE CONTENT. RENISHAW EXCLUDES LIABILITY, HOWSOEVER ARISING, FOR ANY INACCURACIES IN THIS DOCUMENT.

The packaging of our products contains the following materials and can be recycled.

Packaging Component	Material	ISO 11469	Recycling Guidance
Outer box	Cardboard	Not applicable	Recyclable
	Polypropylene	PP	Recyclable
Inserts	Low Density Polyethylene Foam	LDPE	Recyclable
	Cardboard	Not applicable	Recyclable
Bags	High Density Polyethylene Bag	HDPE	Recyclable
	Metalised Polyethylene	PE	Recyclable

REACH regulation

Information required by Article 33(1) of Regulation (EC) No. 1907/2006 ("REACH") relating to products containing substances of very high concern (SVHCs) is available at: www.renishaw.com/REACH



The use of this symbol on Renishaw products and/or accompanying documentation indicates that the product should not be mixed with general household waste upon disposal. It is the responsibility of the end user to dispose of this product at a designated collection point for waste electrical and electronic equipment (WEEE) to enable reuse or recycling. Correct disposal of this product will help to save valuable resources and prevent potential negative effects on the environment. For more information, please contact your local waste disposal service or Renishaw distributor.

Storage and handling

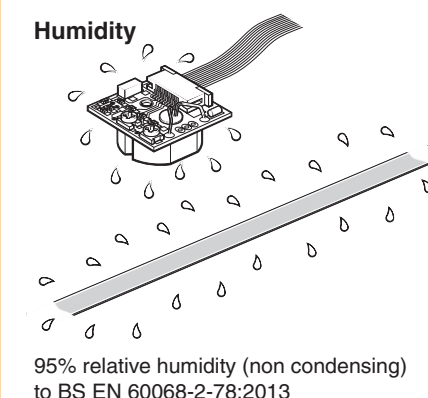
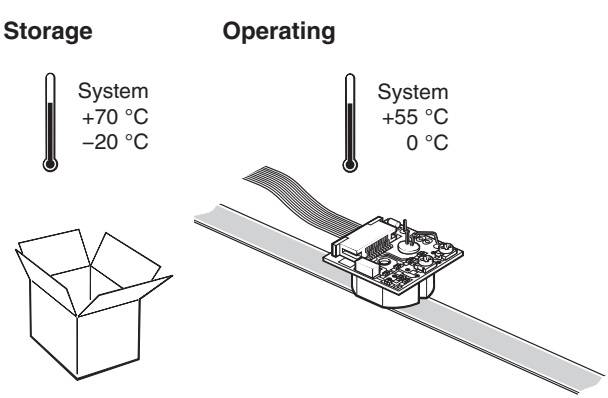
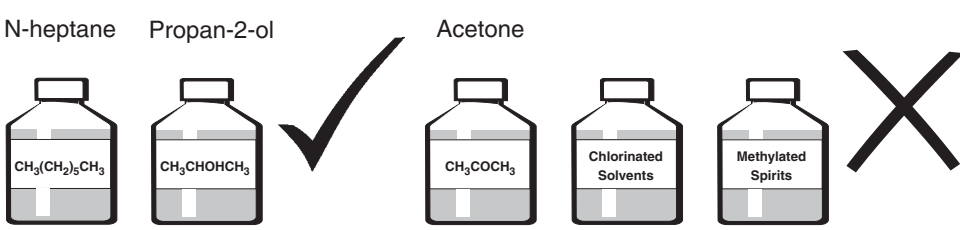
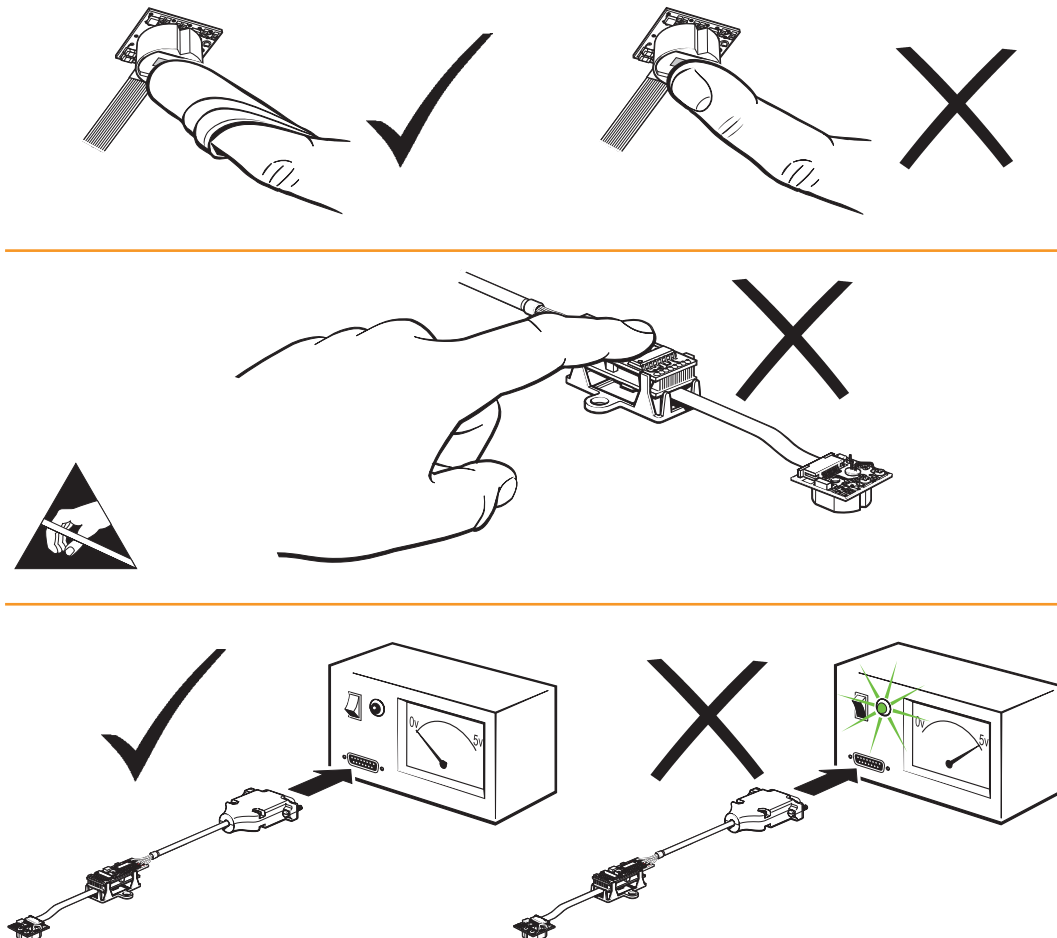
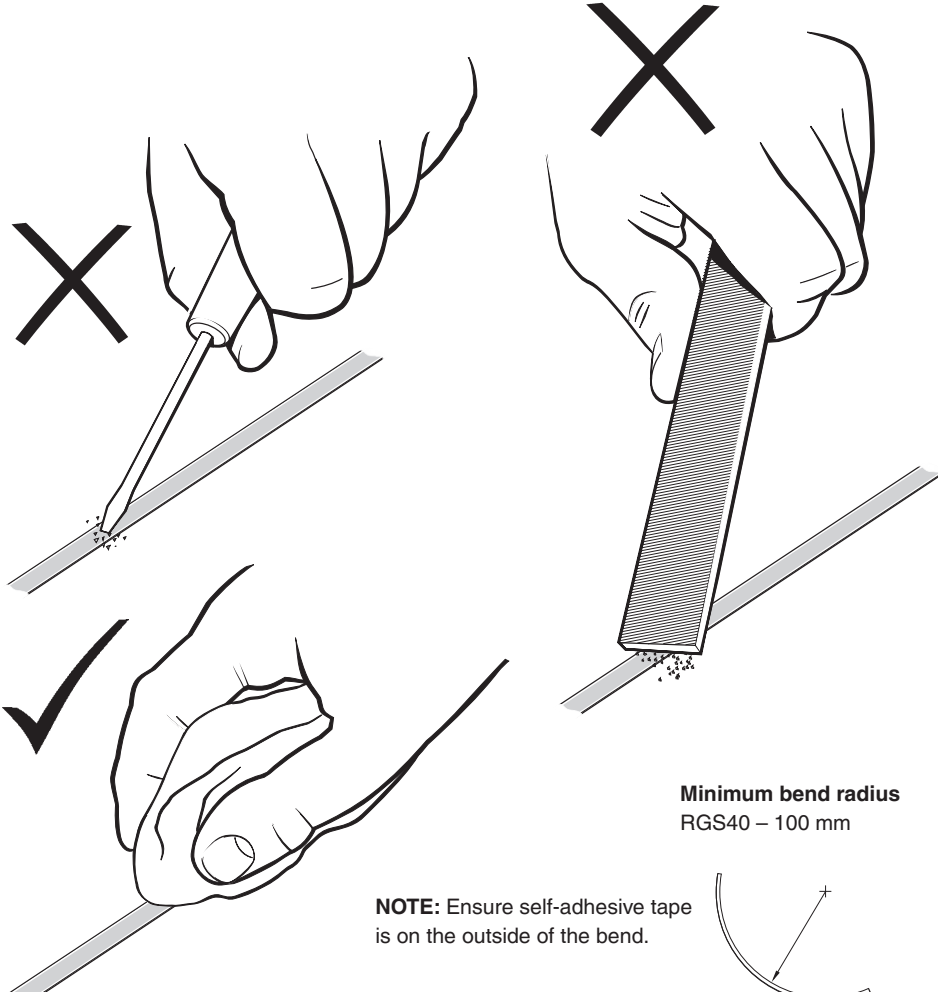

RGH34 readhead installation drawing

Dimensions and tolerances in mm

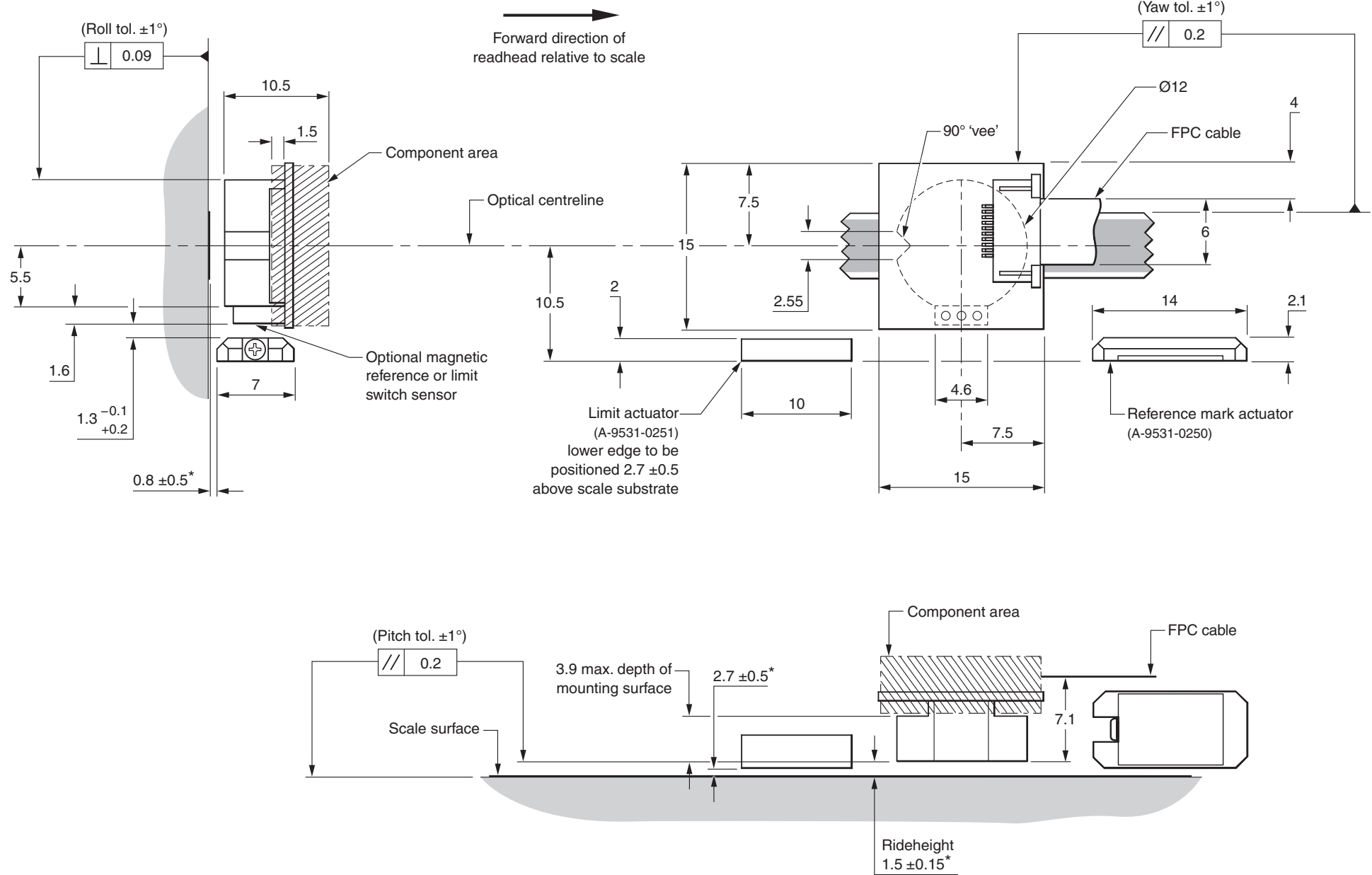

*Dimension measured from scale surface.

RGI34 interface installation drawing

Dimensions and tolerances in mm

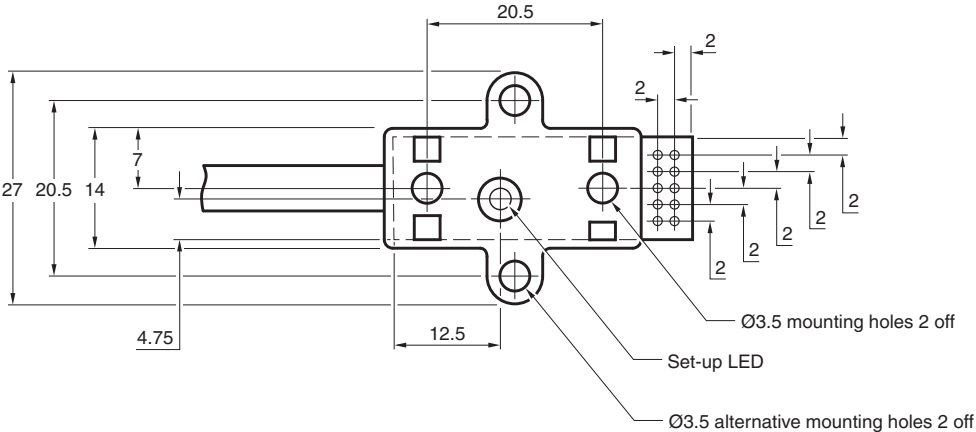
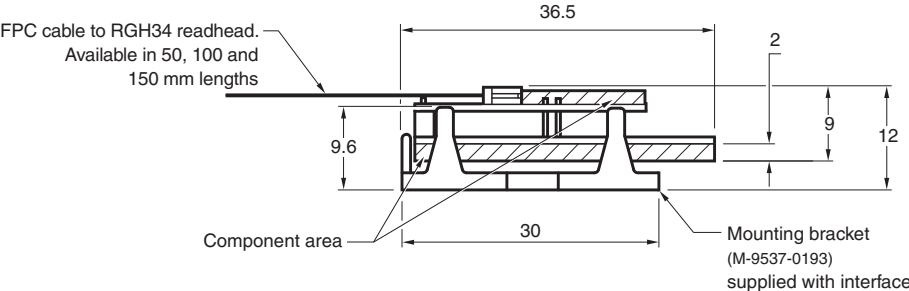
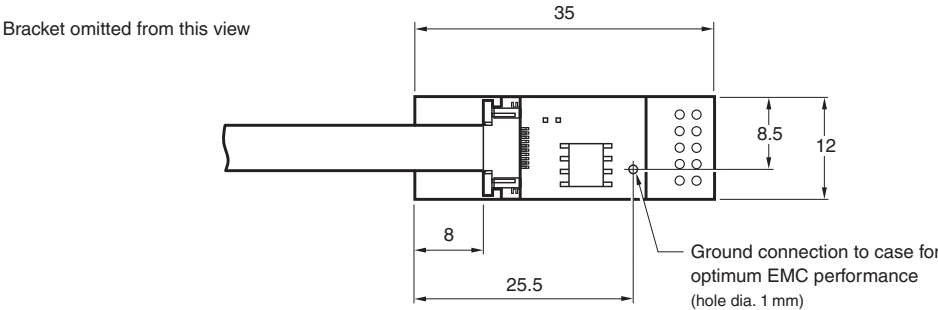

RGS40 scale installation drawing (with reference mark actuator)

Dimensions and tolerances in mm



Bolted reference mark actuator shown
(A-9541-0037)

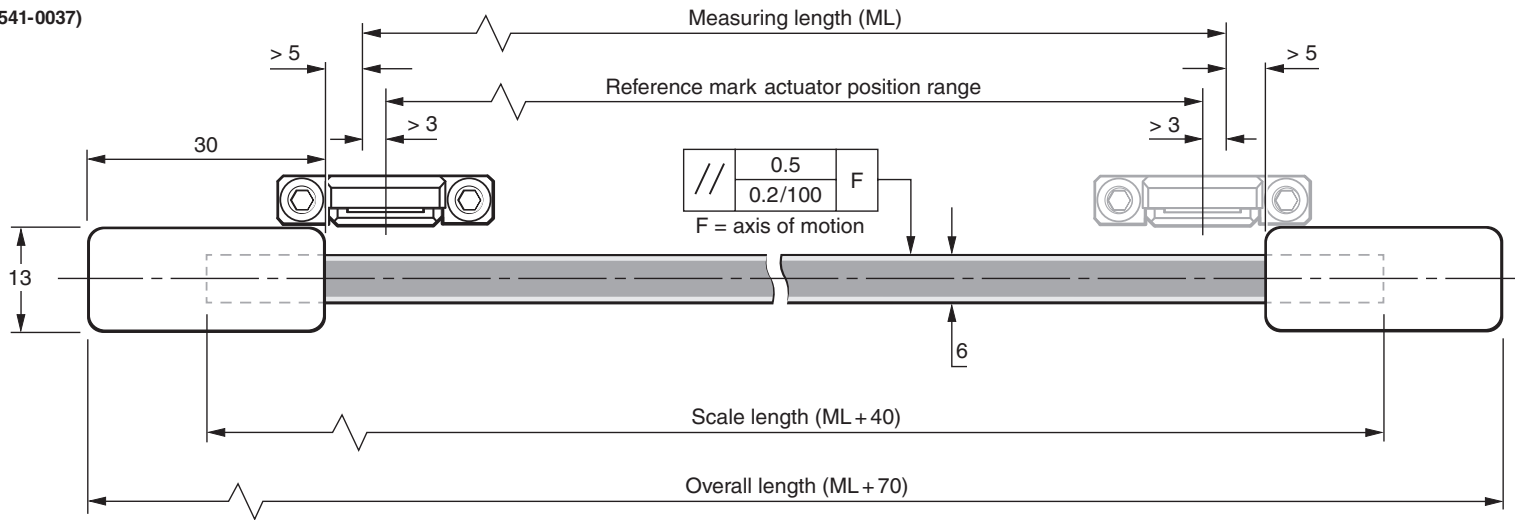

Optional epoxy mounted reference mark actuator
(A-9531-0250)

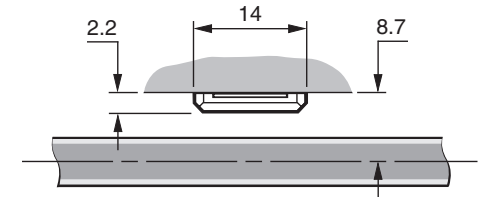

RGS40 scale installation drawing (with limit switch actuator)

Dimensions and tolerances in mm



Bolted limit switch actuator shown
(A-9541-0040)

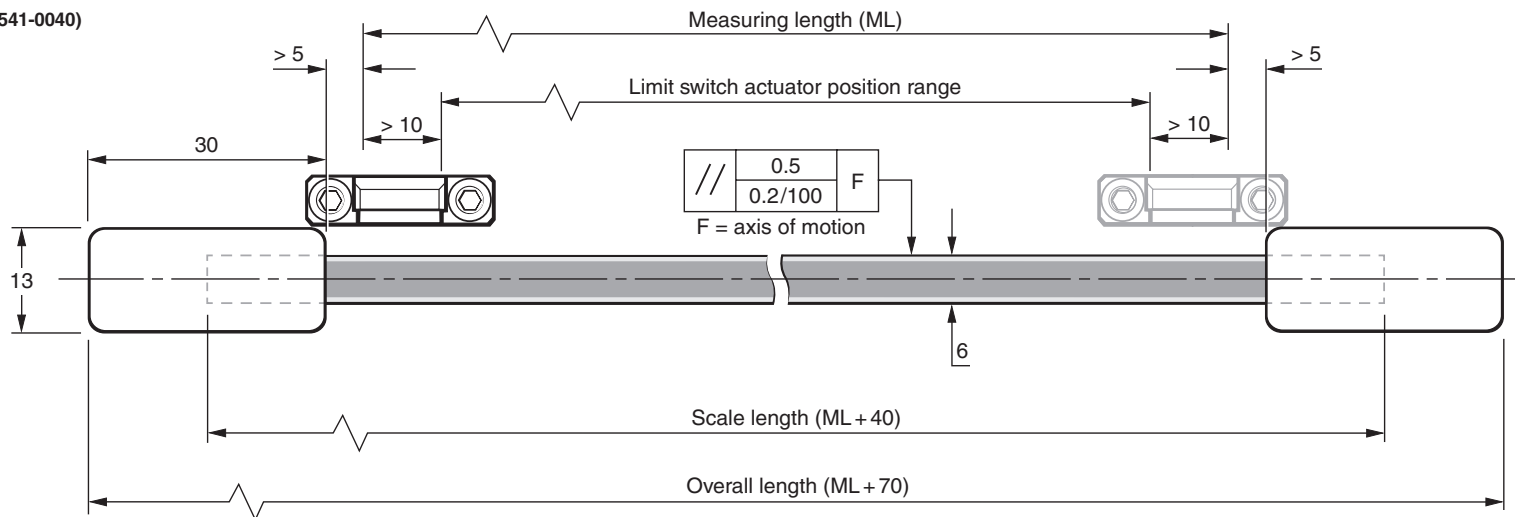

Optional epoxy mounted limit switch actuator
(A-9531-0251)

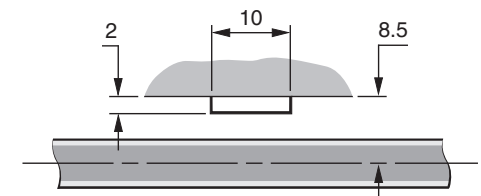

NOTE: The surface roughness of the scale mounting surface must be ≤ 3.2 Ra. The parallelism of the scale surface to the axis of motion (readhead rideheight variation) must be within 0.05 mm.

Scale application

The scale applicator A-9537-0197 is used for installing RGS40 scale for RGH34 systems only.

The RGH34 scale applicator is designed for use with a 'typical' RGH34 mounting bracket, for example:

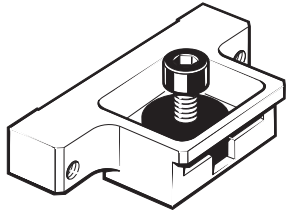

- 1 Allow scale to acclimatize to installation environment prior to installation.
- 2 Thoroughly clean and degrease the substrate using recommended solvents (see 'Storage and handling'). Allow substrate to dry before applying scale.
- 3 Mark out 'START' and 'FINISH' points for the scale on the axis substrate. Ensure that there is room for the end clamps (see 'RGS40 scale installation drawing').
- 4 Locate applicator into mounting bracket, ensuring scale guides on underside of body run parallel to axis of motion. Place the shim supplied with the readhead between the applicator and substrate to set the nominal rideheight.
- 5 Move axis to scale start position, leaving enough room for the scale to be inserted through the applicator.
- 6 Begin to remove the backing paper from the scale and insert scale into the applicator up to the 'START' point. Ensure that the scale runs between the two guides on the bottom of the applicator.
- 7 Apply finger pressure to the scale at the 'START' point, using a clean lint-free cloth, to ensure scale end adheres well to substrate.
- 8 Slowly and smoothly move the applicator through the entire axis of travel, ensuring the backing paper is pulled manually from the scale and does not catch under the applicator.

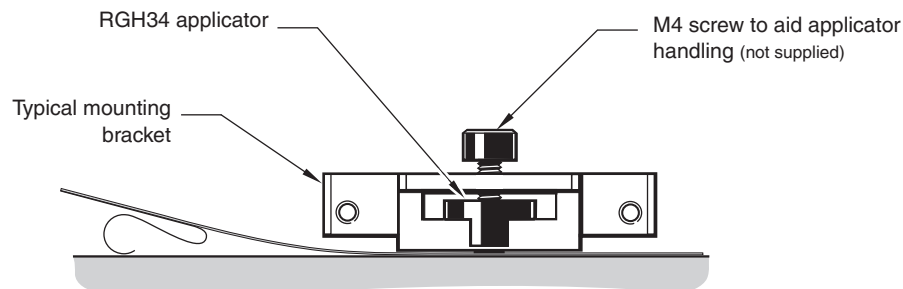

- 9 Remove applicator and, if necessary, adhere remaining scale manually. Apply firm finger pressure via a clean lint-free cloth along the length of the scale after application to ensure complete adhesion.
- 10 Clean the scale using Renishaw scale wipes (A-9523-4040) or a clean, dry, lint-free cloth.

- 11 Fit end clamps (see 'End clamps' section).
- 12 Allow 24 hours for complete adhesion of scale before fitting the reference mark or limit magnet.

End clamps

A-9523-4015 is an end clamp kit designed to be used with Renishaw RGS scale.

IMPORTANT: End clamps should be used to ensure positional stability of the scale and reference mark repeatability.

NOTE: End clamps can be mounted before or after readhead installation.

- 1 Remove the lacquer coating from the last 15 mm of each end of the scale with a knife and clean with one of the recommended solvents (see 'Storage and handling').
- 2 Thoroughly mix up a sachet of glue (A-9531-0342) and apply a small amount to the underside of the end clamp.

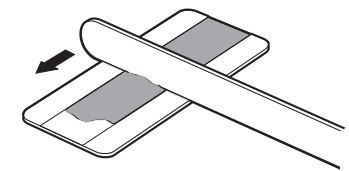
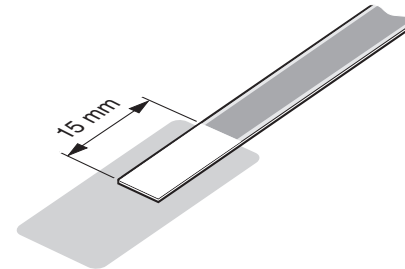

- 3 The end clamp features two small regions of contact adhesive. These will temporarily hold the end clamp in position while the glue cures. Remove the backing tape from either side.
- 4 Immediately position end clamp over the end of the scale. Allow 24 hours at 20 °C for full cure.

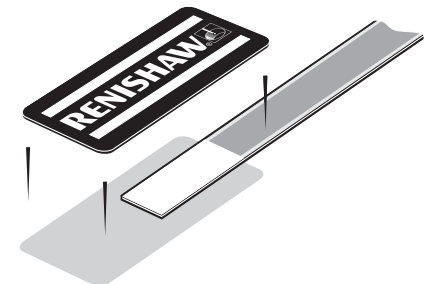
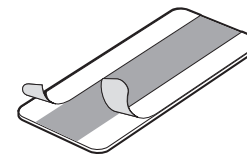

! Ensure that excess glue is wiped away from scale as it may affect the readhead signal level.

Reference mark and limit switch actuator installation

Screw mounted or adhesive mounted reference mark and limit switch actuators are available. Refer to RGH34 readhead installation drawing and RGS40 scale installation drawing for actuator positioning.

Readhead mounting/installation

Mounting brackets

The RGH34 is designed to be integrated into OEM products, and as such the recommendations given here for mounting brackets are intended only as a guide.

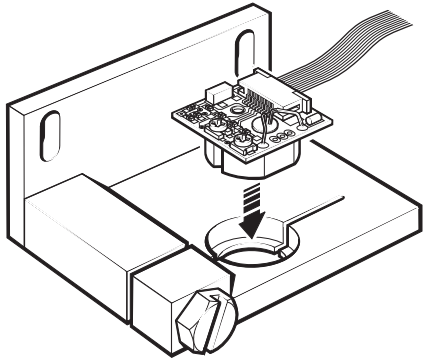

It is recommended that the cylindrical body of the RGH34 be located by a stepped bore (diameter 12.10 mm ±0.05 mm) and that it is fixed in place by means of a clamping mechanism (as shown), or affixed by a suitable adhesive. Care should be taken to ensure that an even pressure is applied to the cylindrical body to prevent distortion of the optics.

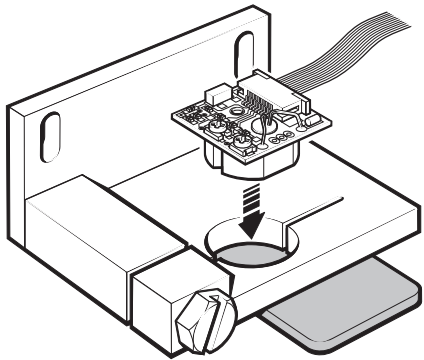

An alternative arrangement is to mount the readhead in a through-hole bracket, whilst using a 1.5 mm shim to maintain ride height tolerance. Again, the body can be secured by a clamping mechanism or by a suitable adhesive.

For readheads that incorporate reference mark or limit switch detection, the bracket should be designed to allow clearance for the magnetic reference/limit sensor and actuator. A 'V' shaped groove in the cylindrical body is provided as an aid to yaw alignment (see installation drawing).

FPC cable insertion

The FPC cable connectors on the RGH34 readhead and RGI34 interface are of the ZIF (zero insertion force) type.

Prior to insertion, the clip (indicated) on the connector should be pulled forward to the open position.

The cable can then be inserted, connections uppermost, into the connector body.

The clip should then be pushed back to the closed position, securing the cable in place.

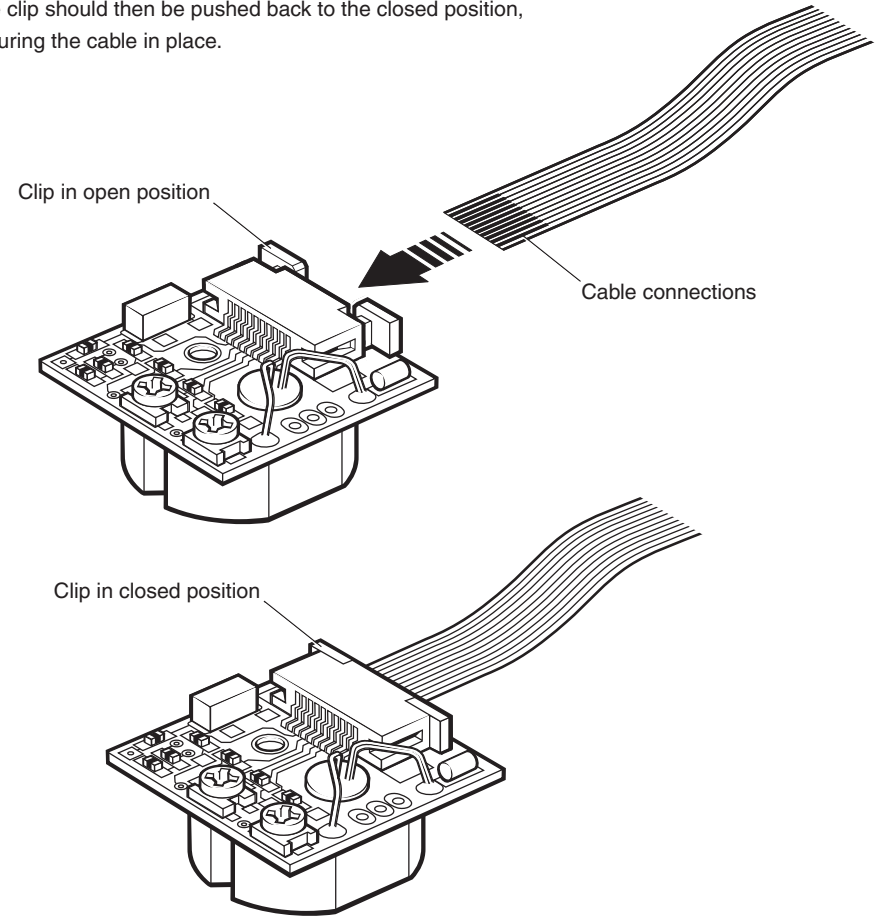

FPC cables

FPC (flexible printed circuit) cables should be ordered separately from your local Renishaw representative.

Part	Part number
50 mm FPC	A-9537-0182
100 mm FPC	A-9537-0183
150 mm FPC	A-9537-0184

Readhead set-up

When mounting the readhead, ensure that the scale, readhead optical window and mounting surfaces are clean and free from obstructions.

NOTE: Refer to 'Maintenance and cleaning' section of this manual for cleaning instructions.

Adjusting set-up

Once the readhead is positioned, the rideheight, pitch, yaw and roll of the unit may need to be adjusted to achieve optimum signal strength. It should be noted that the readhead and interface must be properly connected to the power supply to enable the set-up LED to be used.

Confirming set-up

For reliable operation, the LED should be Green when the readhead is moved slowly (< 1 m/s) along the full axis travel.

NOTE: The set-up LED will not indicate an optimised set-up over the reference mark. For further details, refer also to 'Reference mark set-up'.

The set-up LED will exhibit one of three colours during normal use;



Set-up tolerances

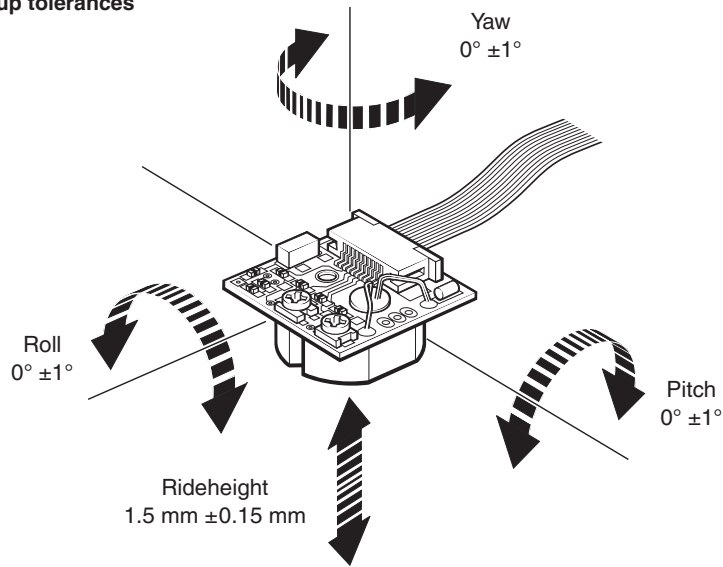

Reference mark set-up

To ensure unidirectional repeatability, the reference mark requires phasing with the scale in the direction of normal datuming operation. A reference pulse is output in both directions, but repeatability is guaranteed only in the phased direction. Ensure readhead is set up correctly with a green LED indication over the full length of travel and that the reference mark actuator is fitted correctly.

NOTE: It is recommended that a datum procedure is performed as part of any power-up sequence to ensure the correct datum position is recorded.

NOTE: Reference mark output is synchronised with the incremental channels, giving unit of resolution pulse width.

NOTE: Check that the reference mark sensing option has been specified on the RGH34 and RGI34 that you have purchased.

Phasing procedure

The readhead must be moved over the reference mark in the direction to be used for the datuming operation. The reference mark is phased correctly when the set-up LED flashes Red for 0.25 seconds. If the set-up LED flashes Orange or goes Blank, the reference mark adjuster screw should be turned anti-clockwise by $\frac{1}{8}$ turn and the procedure repeated until a Red flash is obtained.

NOTE: If the readhead mounting is disturbed at any time, the reference mark will have to be re-phased.

A reference pulse is output in both directions, but because the reference mark can only be phased for one direction of traverse, any indication from the LED when the readhead is moved in the reverse direction is to be ignored. LED flash duration is a constant 0.25 seconds, regardless of traverse speed.

LED repeater (external LED driver) signals will mimic the on-board LED apart from the 'Blank' condition.

The repeater LED will go Blank when the incremental output is in error (3-state).

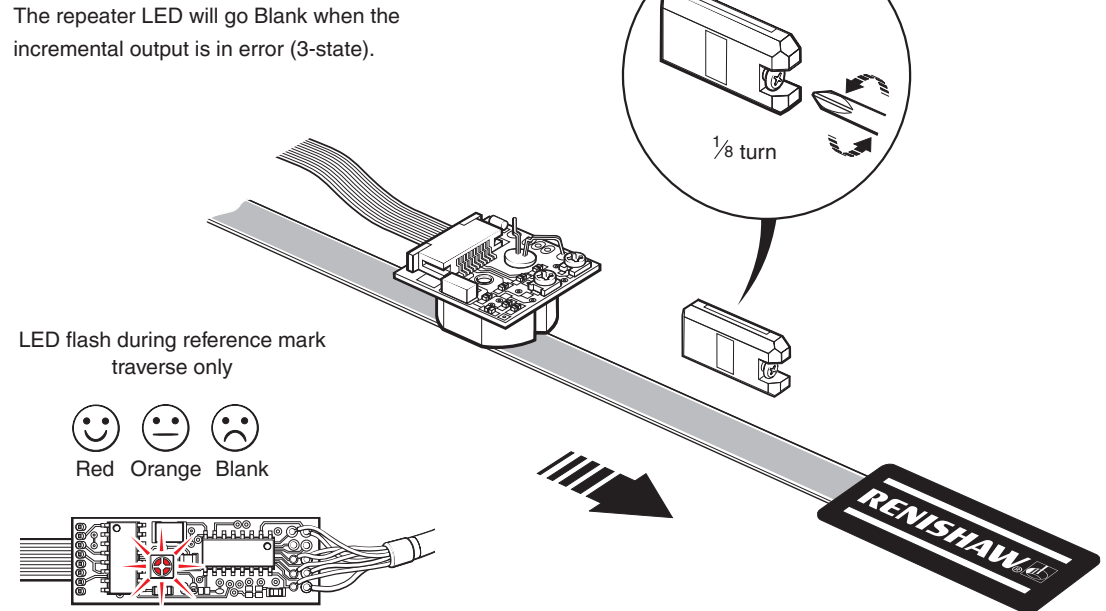

Limit switch

A limit switch signal is output when the readhead sensor passes the magnetic actuator.
For full output specification refer to *RGH34 encoder system* Data sheet (Renishaw part no. L-9517-9728).

CAUTION: The limit switch feature must never be used as a fail-safe stop device.

NOTE: Check that the limit switch sensing option has been specified on the RGH34 and RGI34 that you have purchased.

A pulse is output from the readhead for the duration of the passing of the magnetic actuator.
The limit switch provides an end of travel indication, repeatable to < 0.1 mm (typical).

Output signals

Pin out diagram

RGI34 digital RS422A output types T, D, G, X, N, W, Y, H and
RGI34 analogue 1Vpp output type B

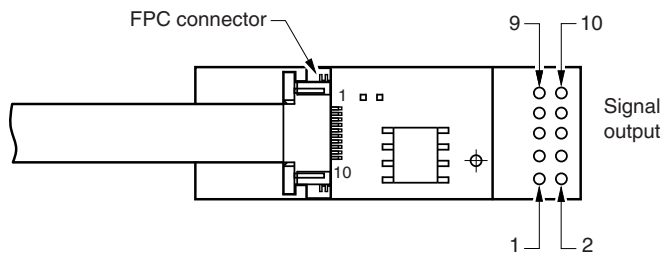

Signal	FPC connector pin
0 V	1, 2
A phase	3
B phase	4
C phase	5
V mid	6
Hall	7
5 V	8, 9, 10

Digital	Output signal	Through hole
Power	5 V	9
	0 V	10
Incremental signals	A+	8
	A-	7
	B+	2
	B-	1
Reference mark (Z) or Limit switch (Q) (if fitted)	Z-/Q+	6
	Z+/Q-	5
External LED driver	Red	4
	Green	3

Analogue	Output signal	Through hole
Power	5 V	9
	0 V	10
Incremental signals	V ₁ +	8
	V ₁ -	7
	V ₂ +	6
	V ₂ -	5
Reference mark (if fitted)	V ₀ +	2
	V ₀ -	1

Speed

Digital interfaces

Non-clocked output interfaces.

Interface type	Maximum speed (m/s)	Lowest recommended counter input frequency (MHz)
T (10 μm)	8	$\left(\frac{\text{Encoder velocity (m/s)}}{\text{Resolution (μm)}} \right) \times 4 \text{ safety factor}$
D (5 μm)	8	
G (2 μm)	7.5	
X (1 μm)	6	

Clocked output interfaces

The RGI34N, W, Y and H interfaces are available with a variety of different clocked outputs.
Customers must ensure they comply with the lowest recommended counter input frequency.

Clocked output code	Maximum speed (m/s)				Lowest recommended counter input frequency (MHz)
	Interface type				
	N (0.4 μm)	W (0.2 μm)	Y (0.1 μm)	H (50 nm)	
30	-	1.3	0.6	0.3	12
31	-	0.9	0.45	0.2	8
32	1.3	-	-	-	6
33	0.9	0.45	0.2	0.1	4

Analogue interface

RGI34B - 6 m/s (-3dB)
8 m/s (-6dB)

Electrical connections

Grounding and shielding

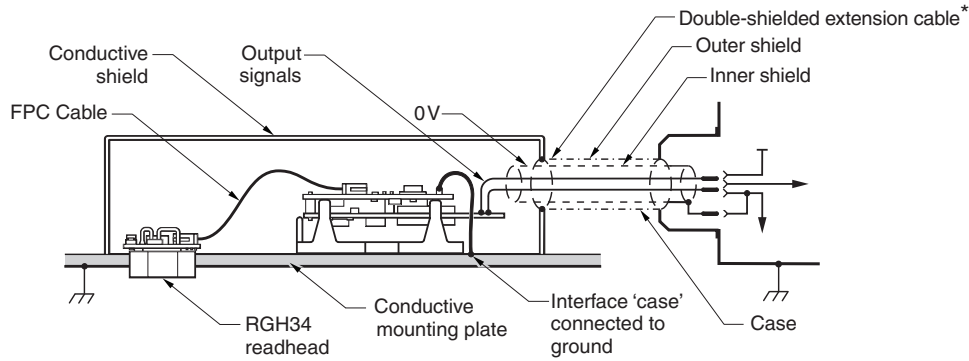

*Maximum extension cable length
 RGI34B - 100 m, RGI34T, D, G and X - 50 m, RGI34N, W, Y and H - 20 m

For optimum performance, ensure 100% screening

- Ground the readhead mounting bracket
- Ensure continuity of all shields
- Use double shielded extension cable
- Connect interface CASE to ground
- Use shielded connector shells on all cable connections
- Terminate the inner shield to 0 V power at the customer interface
- Maximise the distance between encoder and motor cables

Recommended signal termination

Digital outputs - RGI34T, D, G, X, N, W, Y and H

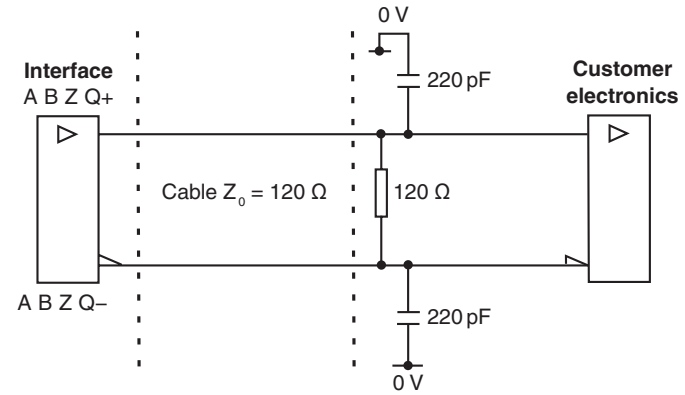

Standard RS422A line receiver circuitry
 Capacitors recommended for improved noise immunity.

Analogue output - RGI34B

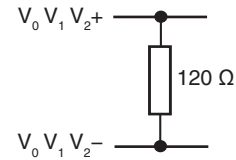

Remote LED driver outputs

The remote LED driver output allows remote monitoring of readhead installation.

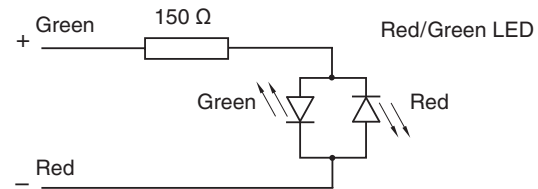

Output specifications

Digital output signals - type RGI34T, D, G, X, N, W, Y and H

Form - Square wave differential line driver to EIA RS422A

Incremental[†] 2 channels A and B in quadrature (90° phase shifted)

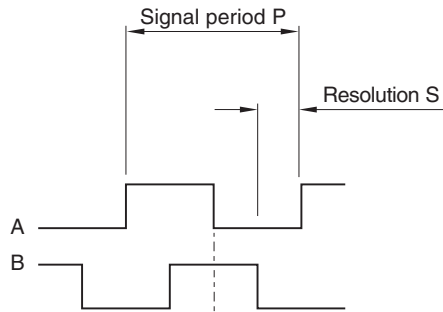

Model	P (μm)	S (μm)
RGI34T	40	10
RGI34D	20	5
RGI34G	8	2
RGI34X	4	1
RGI34N	1.6	0.4
RGI34W	0.8	0.2
RGI34Y	0.4	0.1
RGI34H	0.2	0.05

Reference[†]

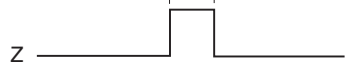

Synchronised pulse Z, duration as resolution S.
Repeatability of position (uni-directional) maintained within ± 20 °C from installation temperature and for speed < 0.5 m/s.
Actuation device: A-9531-0250 or A-9541-0037

Limit[†] Asynchronous pulse

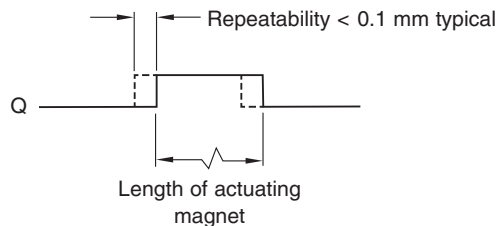

NOTE: RGH34 readheads and RGI34 digital interfaces are available with reference mark or limit switch detection.
Select output option at order.
Actuation device: A-9531-0251, A-9531-2052, A-9531-2054 or A-9541-0040

Alarm

3-state alarm

Incremental channels forced open circuit for > 20 ms when signal too low for reliable operation.
For RGI34N, W, Y and H only, incremental channels forced open circuit for > 10 ms when signal too low or speed too high for reliable operation.

[†]Inverse signals not shown for clarity

Analogue output signals - type RGI34B (1 Vpp)

Incremental 2 channels V_1 and V_2 differential sinusoids in quadrature (90° phase shifted)

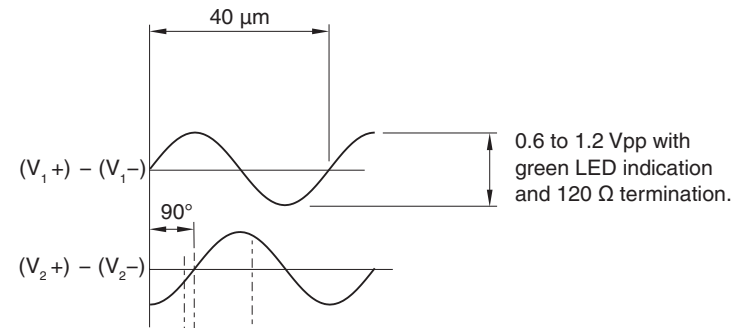

Reference

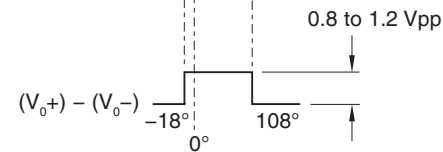

Differential pulse V_0 -18° to 108°.
Duration 126° (electrical).
Repeatability of position (uni-directional) maintained within ± 20 °C from installation temperature and for speed < 0.5 m/s.
Actuation device: A-9531-0250 or A-9531-0037

General specifications

Power supply	5 V \pm 5%	120 mA
	<p>NOTE: Current consumption figures refer to unterminated RGI34 interfaces.</p> <p>For digital outputs a further 25 mA per channel pair (e.g. A+, A-) will be drawn when terminated with 120 Ω.</p> <p>For analogue outputs a further 20 mA will be drawn when terminated with 120 Ω.</p> <p>Power from a 5 V dc supply complying with the requirements for SELV of standard IEC BS EN 60950-1.</p>	
	Ripple	200 mVpp @ frequency up to 500 kHz maximum
Temperature	Storage	-20 °C to +70 °C
	Operating	0 °C to +55 °C
Humidity		95 % relative humidity (non-condensing) to EN 60068-2-78
Acceleration	Operating	500 m/s ² , 3 axes
Shock	Non-operating	1000 m/s ² , 6 ms, ½ sine, 3 axes
Vibration	Operating	100 m/s ² max @ 55 Hz to 2000 Hz, 3 axes
Mass	Readhead	2 g
	Interface	3 g
Readhead to interface connections		Very low profile zero insertion force micro-connector for 10-way Flexible Printed Circuit (FPC) cable. Cable flex life minimum 10 \times 10 ⁹ cycles at 5 mm bend radius.

Scale specifications

Scale type		Reflective gold plated steel tape with protective lacquer coating. Adhesive backing tape allows direct mounting to the machine substrate.
Scale period		40 μ m
Linearity		\pm 3 μ m/m
Scale length		Up to 50 m (> 50 m by special order)
Form (H \times W)		0.2 mm \times 6 mm (includes adhesive)
Substrate materials		Metals, ceramics and composites with expansion coefficients between 0 and 22 μ m/m/°C (steel, aluminium, Invar, granite, ceramic etc.)
Coefficient of thermal expansion		Matches that of substrate material when scale ends are fixed by epoxy mounted end clamps
End fixing		Epoxy mounted end clamps (A-9523-4015) using 2 part epoxy adhesive (A-9531-0342) Scale end movement typically < 1 μ m up to 40 °C
Temperature	Operating	-10 °C to +120 °C.
	Minimum installation	10 °C
	Storage	-20 °C to +70 °C.
Humidity		95% relative humidity (non-condensing) to EN 60068-2-78

Renishaw plc
New Mills, Wotton-under-Edge
Gloucestershire, GL12 8JR
United Kingdom

T +44 (0)1453 524524
F +44 (0)1453 524901
E uk@renishaw.com
www.renishaw.com

RENISHAW 
apply innovation™

For worldwide contact details, visit www.renishaw.com/contact

RENISHAW HAS MADE CONSIDERABLE EFFORTS TO ENSURE THE CONTENT OF THIS DOCUMENT IS CORRECT AT THE DATE OF PUBLICATION BUT MAKES NO WARRANTIES OR REPRESENTATIONS REGARDING THE CONTENT. RENISHAW EXCLUDES LIABILITY, HOWSOEVER ARISING, FOR ANY INACCURACIES IN THIS DOCUMENT.

© 2001-2019 Renishaw plc. All rights reserved.

Renishaw reserves the right to change specifications without notice.

RENISHAW and the probe symbol used in the RENISHAW logo are registered trade marks of Renishaw plc in the United Kingdom and other countries.

apply innovation and names and designations of other Renishaw products and technologies are trade marks of Renishaw plc or its subsidiaries.

All other brand names and product names used in this document are trade names, trade marks or registered trade marks of their respective owners.



M - 9537 - 9024 - 01

Part no.: M-9537-9024-01-D

Issued: 11.2019