

# RLP40 (QE) radio lathe probe



© 2022 Renishaw plc. All rights reserved.

This document may not be copied or reproduced in whole or in part, or transferred to any other media or language, by any means, without the prior written permission of Renishaw plc.

Renishaw plc. Registered in England and Wales. Company no: 1106260. Registered office: New Mills, Wotton-under-Edge, Gloucestershire, GL12 8JR, UK.

Compliance information for this product is available by scanning the QR code or visiting [www.renishaw.com/mtpdoc](http://www.renishaw.com/mtpdoc)



# Contents

<b>Before you begin</b> .....	1.1
Disclaimer .....	1.1
Trade marks .....	1.1
Warranty .....	1.1
Changes to equipment .....	1.1
CNC machines .....	1.2
Care of the probe .....	1.2
Patents .....	1.2
RLP40 (model RLP40QE) software notices .....	1.3
RLP40 (model RLP40QE) software licensing agreement .....	1.3
Intended use .....	1.4
Safety .....	1.4
<b>RLP40 basics</b> .....	2.1
Introduction .....	2.1
RLP40H .....	2.2
Getting started .....	2.2
System interface .....	2.2
Probe configuration .....	2.3
Opti-Logic™ .....	2.3
Trigger Logic™ .....	2.3
Probe modes .....	2.3
Configurable settings .....	2.4
Switch-on / switch-off methods .....	2.4
Trigger filter .....	2.5
Hibernation mode .....	2.5
Multiple probe mode .....	2.6
Partnering mode .....	2.7
RLP40 dimensions .....	2.8

RLP40 and RLP40H specification . . . . .	2.9
Typical battery life . . . . .	2.10
<b>System installation . . . . .</b>	<b>3.1</b>
Installing the RLP40 with an RMI-Q or RMI-QE . . . . .	3.1
Operating envelope . . . . .	3.1
Positioning the RLP40 and RMI-Q or RMI-QE . . . . .	3.2
Performance envelope . . . . .	3.2
Preparing the RLP40 for use . . . . .	3.3
Fitting the stylus . . . . .	3.3
Installing the batteries . . . . .	3.4
Mounting the probe on a shank . . . . .	3.5
Stylus on-centre adjustment . . . . .	3.6
Stylus trigger force and adjustment (RLP40 only) . . . . .	3.7
Calibrating the RLP40 . . . . .	3.8
Why calibrate a probe? . . . . .	3.8
Calibrating in a bored hole or on a turned diameter . . . . .	3.8
Calibrating in a ring gauge or on a datum sphere . . . . .	3.8
Calibrating the probe length . . . . .	3.9
<b>Probe configuration . . . . .</b>	<b>4.1</b>
Configuring the probe using the Probe Setup app . . . . .	4.1
Using Opti-Logic™ . . . . .	4.1
Reviewing the probe settings . . . . .	4.2
Multiple probe mode settings . . . . .	4.3
Probe settings record . . . . .	4.4
Probe partnering function . . . . .	4.5
With RMI-Q switched on . . . . .	4.6
With RMI-QE switched on . . . . .	4.6
RLP40 – RMI-Q partnership . . . . .	4.7
RLP40 – RMI-QE partnership . . . . .	4.8
Changing the probe settings when partnered to an RMI-Q . . . . .	4.10
Changing the probe settings when partnered to an RMI-QE . . . . .	4.13
Master reset function . . . . .	4.15
Operating mode . . . . .	4.18

<b>Maintenance</b> .....	5.1
Maintenance .....	5.1
Cleaning the probe .....	5.1
Changing the batteries .....	5.2
RLP40 eyelid .....	5.4
<b>Fault-finding</b> .....	6.1
<b>Parts list</b> .....	7.1

This page is intentionally left blank.

# Before you begin

## Disclaimer

WHILE CONSIDERABLE EFFORT WAS MADE TO VERIFY THE ACCURACY OF THIS DOCUMENT AT PUBLICATION, ALL WARRANTIES, CONDITIONS, REPRESENTATIONS AND LIABILITY, HOWSOEVER ARISING, ARE EXCLUDED TO THE EXTENT PERMITTED BY LAW.

RENISHAW RESERVES THE RIGHT TO MAKE CHANGES TO THIS DOCUMENT AND TO THE EQUIPMENT, AND/OR SOFTWARE AND THE SPECIFICATION DESCRIBED HEREIN WITHOUT OBLIGATION TO PROVIDE NOTICE OF SUCH CHANGES.

## Trade marks

RENISHAW® and the probe symbol are registered trade marks of Renishaw plc. Renishaw product names, designations and the mark 'apply innovation' are trade marks of Renishaw plc or its subsidiaries.

Google Play and the Google Play logo are trademarks of Google LLC.

Apple and the Apple logo are trademarks of Apple Inc., registered in the U.S. and other countries. App Store is a service mark of Apple Inc., registered in the U.S. and other countries.

Other brand, product or company names are trade marks of their respective owners.

## Warranty

Unless you and Renishaw have agreed and signed a separate written agreement, the equipment and/or software are sold subject to the Renishaw Standard Terms and Conditions supplied with such equipment and/or software, or available on request from your local Renishaw office.

Renishaw warrants its equipment and software for a limited period (as set out in the Standard Terms and Conditions), provided that they are installed and used exactly as defined in associated Renishaw documentation. You should consult these Standard Terms and Conditions to find out the full details of your warranty.

Equipment and/or software purchased by you from a third-party supplier is subject to separate terms and conditions supplied with such equipment and/or software. You should contact your third-party supplier for details.

## Changes to equipment

Renishaw reserves the right to change equipment specifications without notice.

## CNC machines

CNC machine tools must always be operated by fully trained personnel in accordance with the manufacturer's instructions.

## Care of the probe

Keep system components clean and treat the probe as a precision tool.

## Patents

Features of the RLP40 and RLP40H, and other similar Renishaw products, are the subject of one or more of the following patents and/or patent applications:

CN 100416216	IN 215787	US 6941671
CN 100466003	IN 234921	US 7145468
CN 101476859	IN 8707/DELNP/2008	US 7285935
CN 101482402	IN WO2004/057552	US 7316077
EP 1425550	JP 4237051	US 7441707
EP 1457786	JP 4575781	US 7486195
EP 1576560	JP 4852411	US 7665219
EP 1613921	JP 5238749	US 7812736
EP 1804020	JP 5390719	US 7821420
EP 1931936	KR 1001244	US 9140547
EP 2216761	TW I333052	



## **RLP40 (model RLP40QE) software notices**

This RLP40 product includes embedded software (firmware) to which the following notices apply:

### **US government notice**

#### **NOTICE TO UNITED STATES GOVERNMENT CONTRACT AND PRIME CONTRACT CUSTOMERS**

This software is commercial computer software that has been developed by Renishaw exclusively at private expense. Notwithstanding any other lease or licence agreement that may pertain to, or accompany the delivery of, this computer software, the rights of the United States Government and/or its prime contractors regarding its use, reproduction and disclosure are as set forth in the terms of the contract or subcontract between Renishaw and the United States Government, civilian federal agency or prime contractor respectively. Please consult the applicable contract or subcontract and the software licence incorporated therein, if applicable, to determine your exact rights regarding use, reproduction and/or disclosure.

### **Renishaw software EULA**

Renishaw software is licensed in accordance with the Renishaw licence at:  
[www.renishaw.com/legal/softwareterms](http://www.renishaw.com/legal/softwareterms)

## **RLP40 (model RLP40QE) software licensing agreement**

This RLP40 product includes the following third-party software:

### **BSD 3-Clause Licence**

Copyright © 2009 – 2015 ARM LIMITED. All rights reserved.

Redistribution and use in source and binary forms, with or without modification, are permitted provided that the following conditions are met:

1. Redistributions of source code must retain the above copyright notice, this list of conditions and the following disclaimer.
2. Redistributions in binary form must reproduce the above copyright notice, this list of conditions and the following disclaimer in the documentation and/or other materials provided with the distribution.
3. Neither the name of ARM nor the names of its contributors may be used to endorse or promote products derived from this software without specific prior written permission.

THIS SOFTWARE IS PROVIDED BY THE COPYRIGHT HOLDERS AND CONTRIBUTORS “AS IS” AND ANY EXPRESS OR IMPLIED WARRANTIES, INCLUDING, BUT NOT LIMITED TO, THE IMPLIED WARRANTIES OF MERCHANTABILITY AND FITNESS FOR A PARTICULAR PURPOSE ARE DISCLAIMED. IN NO EVENT SHALL COPYRIGHT HOLDERS AND CONTRIBUTORS BE LIABLE FOR ANY DIRECT, INDIRECT, INCIDENTAL, SPECIAL, EXEMPLARY, OR CONSEQUENTIAL DAMAGES (INCLUDING, BUT NOT LIMITED TO, PROCUREMENT OF SUBSTITUTE GOODS OR SERVICES; LOSS OF USE, DATA, OR PROFITS; OR BUSINESS INTERRUPTION) HOWEVER CAUSED AND ON ANY THEORY OF LIABILITY, WHETHER IN CONTRACT, STRICT LIABILITY, OR TORT (INCLUDING NEGLIGENCE OR OTHERWISE) ARISING IN ANY WAY OUT OF THE USE OF THIS SOFTWARE, EVEN IF ADVISED OF THE POSSIBILITY OF SUCH DAMAGE.

## Intended use

The RLP40 is a radio lathe probe that enables automated workpiece inspection and job set-up on multi-tasking machines and lathes.

## Safety

### Information to the user

This product is supplied with non-rechargeable lithium metal batteries. Refer to the battery manufacturer's literature for specific battery operating, safety and disposal guidelines.

- Do not attempt to recharge the batteries.
- Replace the batteries only with the specified type.
- Do not mix new and used batteries in the product.
- Do not mix different types or brands of batteries in the product.
- Ensure that all batteries are inserted with the correct polarity in accordance with the instructions in this manual and indicated on the product.
- Do not store the batteries in direct sunlight.
- Do not expose the batteries to water.
- Do not expose the batteries to heat or dispose of the batteries in a fire.
- Avoid forced discharge of the batteries.
- Do not short circuit the batteries.
- Do not disassemble, apply excessive pressure, pierce, deform or subject the batteries to impact.
- Do not swallow the batteries.
- Keep the batteries out of the reach of children.
- If the batteries are swollen or damaged do not use them in the product and exercise caution when handling them.
- Dispose of waste batteries in accordance with your local environmental and safety laws.

Ensure that you comply with international and national battery transport regulations when transporting the batteries or this product with the batteries inserted. Lithium metal batteries are classified as dangerous goods for transportation and require labelling and packaging in accordance with the dangerous goods regulations before being offered for transportation. To reduce the risk of shipment delays, should you need to return this product for any reason, do not return any batteries.

In all applications involving the use of machine tools, eye protection is recommended.

The RLP40 has a glass window. Handle with care if broken to avoid injury.

## Information to the machine supplier/installer

It is the machine supplier's responsibility to ensure that the user is made aware of any hazards involved in operation, including those mentioned in Renishaw product literature, and to ensure that adequate guards and safety interlocks are provided.

If the probe system fails, the probe signal may falsely indicate a probe seated condition. Do not rely on probe signals to halt the movement of the machine.

## Information to the equipment installer

All Renishaw equipment is designed to comply with the relevant UK, EU and FCC regulatory requirements. It is the responsibility of the equipment installer to ensure that the following guidelines are adhered to, in order for the product to function in accordance with these regulations:

- Any interface **MUST** be installed in a position away from any potential sources of electrical noise, (for example power transformers, servo drives).
- All 0 V/ground connections should be connected to the machine "star point" (the "star point" is a single point return for all equipment ground and screen cables). This is very important and failure to adhere to this can cause a potential difference between grounds.
- All screens must be connected as outlined in the user instructions.
- Cables must not be routed alongside high current sources (for example, motor power supply cables), or be near high-speed data lines.
- Cable lengths should always be kept to a minimum.

## Equipment operation

If this equipment is used in a manner not specified by the manufacturer, the protection provided by the equipment may be impaired.

This page is intentionally left blank.

# RLP40 basics

## Introduction

The RLP40 (model RLP40QE) is a new generation radio transmission probe that is compatible for application with either RMI-Q or RMI-QE radio machine interface.

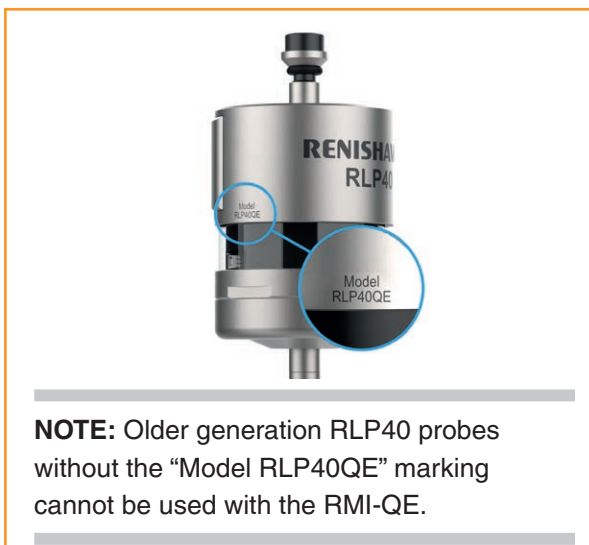

The RLP40 enables automated workpiece inspection and job set-up on multi-tasking machines and lathes.

It is ideally suited to multi-tasking machines and lathes or where line-of-sight between probe and receiver is difficult to achieve or where Z travel is limited.

At only Ø40 mm, this compact probe sets industry standards for functionality, reliability and robustness in the harshest of machine tool environments.

The RLP40 complies with FCC regulations and operates in the 2.4 GHz band. It delivers interference-free transmission through the use of hybrid FHSS (frequency-hopping spread spectrum) technology, which allows multiple systems to operate in the same machine shop without risk of cross-interference.

All RLP40 settings are configured using either Opti-Logic™ or Trigger Logic™. These techniques enable the user to review and subsequently change probe settings.

Configurable settings are:

- Switch-on / switch-off method
- Trigger filter setting
- Hibernation setting\*
- Multiple probe mode\*

\* in RMI-Q mode only.

## RLP40H

The RLP40H variant is configured with high stylus trigger forces, making it particularly suitable for application on machines that produce high levels of shock and vibration.

### Getting started

Three multicolour probe LEDs provide visual indication of selected probe settings and status.

For example:

- Switch-on and switch-off methods
- Probe status – triggered or seated
- Battery condition

Batteries are inserted or removed as shown (for more information, see page 3.4, “**Installing the batteries**”).

On insertion of batteries, the LEDs will begin to flash starting with an LED check (for more information, see page 4.2, “**Reviewing the probe settings**”). An LED check displaying a single flash of red, green, blue indicates that the probe is operating in RMI-Q mode. An LED check displaying double flashes of red, green, blue indicates that the probe is operating in RMI-QE mode.

### System interface

The RMI-Q or RMI-QE is an integrated interface/receiver used to communicate between the RLP40 probe and the machine controller. For more details, refer to the *RMI-Q radio machine interface* installation guide (Renishaw part no. H-5687-8504) or the *RMI-QE radio machine interface* installation guide (Renishaw part no. H-6551-8520).

It is necessary that the RLP40 is partnered to either an RMI-Q or RMI-QE. Prior to partnering for the first time, the RLP40 is pre-set to operate in RMI-QE mode. The LED check will display a double flashes of red, green, blue.

---

**NOTE:** The RLP40 (model RLP40QE) is **not** compatible with the older RMI integrated interface/receiver.

---

## Probe configuration

It is recommended that the Probe Setup app is used to configure the probe.

The Probe Setup app simplifies the process of configuring Renishaw machine tool probes compatible with Opti-Logic™ or Trigger Logic™.

The app provides clear, step-by-step, visual instructions and video tutorials to guide a user through the process of setting up and configuring a Renishaw machine tool probing system.

The Probe Setup app is available for download on the App Store and Google Play and also from several app stores in China.



or



### Opti-Logic™

Opti-Logic is the process of transmitting and receiving data from the app to a Renishaw machine tool probe using pulses of light; for more information, see page 4.1, “**Configuring the probe using the Probe Setup app**”.

### Trigger Logic™

Trigger Logic™ (for more information, see page 4.2, “**Reviewing the probe settings**”) is a method that allows the user to view and select all available mode settings in order to customise a probe to suit a specific application. Trigger Logic is activated by battery insertion and uses a sequence of stylus deflections (triggering) to systematically lead the user through the available choices to allow selection of the required mode options.

Current probe settings can also be reviewed by simply removing the batteries for a minimum of 5 seconds, and then replacing them to activate the Trigger Logic review sequence (for more information, see page 4.2, “**Reviewing the probe settings**”).

## Probe modes

The RLP40 probe can be in one of three modes:

**Standby mode** – Probe is waiting for a switch-on signal.

---

**NOTE:** The RLP40 will enter “**hibernation mode**” should the system interface be powered off or out of range for a period of 30 seconds (“**hibernation mode**” is only applicable to “**radio on mode**” when used with an RMI-Q).

---

**Operational mode** – When activated by one of the switch-on methods, the probe is switched on and ready for use.

**Configuration mode** – Ready to change the probe settings using Opti-Logic or Trigger Logic.

## Configurable settings

### Switch-on / switch-off methods

The following switch-on / switch-off options are user-configurable.

- Radio on / Radio off
- Radio on / Timer off
- Spin on / Spin off
- Spin on / Timer off

RLP40 switch-on method Switch-on options are configurable	RLP40 switch-off method Switch-off options are configurable	Switch-on time
<p><b>Radio on</b></p> <p>Radio switch on is commanded by machine input.</p>	<p><b>Radio off</b></p> <p>Radio switch off is commanded by machine input. A timer automatically switches the probe off 90 minutes after the last trigger or reset if it is not turned off by machine input.</p> <p><b>Timer off (timeout)</b></p> <p>Timeout will occur 12, 33 or 134 seconds (user-configurable) after the last probe trigger or reset.</p>	<p>1 second maximum.</p> <hr/> <p><b>NOTE:</b> This assumes a good radio communication link. In a poor RF environment this may rise to a maximum of 3 seconds.</p> <hr/>
<p><b>Spin on</b></p> <p>Spin at 500 r/min for 1 second minimum.</p>	<p><b>Spin off</b></p> <p>Spin at 500 r/min for 1 second minimum. A timer automatically switches the probe off 90 minutes after the last trigger if it is not spun.</p> <p><b>Timer off (timeout)</b></p> <p>Timeout will occur 12, 33 or 134 seconds (user-configurable) after the last probe trigger or reset.</p>	<p>2 seconds maximum.</p> <hr/> <p><b>NOTE:</b> The 2 seconds starts from the moment the spindle reaches 500 r/min.</p> <hr/>

---

**NOTE:** After being switched on, the RLP40 must be on for 1 second minimum. When using spin on / spin off, ensure that the probe is stationary for 1 second minimum after it has stopped spinning before using spin on / spin off.

---



## Trigger filter

Probes subjected to high levels of vibration or shock loads may output signals without having contacted any surface. RLP40 trigger filter settings improve the probe's resistance to these effects.

Level 1 disables the trigger filter.

Level 2 adds a nominal 10 ms delay to the probe output.

Level 3 adds a nominal 20 ms delay to the probe output.

Factory set to Level 1 (off)

---

**NOTE:** It may be necessary to reduce the probe approach speed to allow for the increased stylus overtravel during the extended time delay.

---

## Hibernation mode

Only applicable to “**radio-on mode**” when RLP40 is used with an RMI-Q.

When the RLP40 is in standby and the RMI-Q is powered off or out of range, the probe enters hibernation; a low power mode designed to save battery life. The probe “wakes” from hibernation to periodically check for its partnered RMI-Q.

The “wake-up” frequency can be set to 30 seconds, 5 seconds or set to off (the probe never goes into hibernation).

The “wake-up” frequency is factory set to 30 seconds.

If its partnered RMI-Q is found, the RLP40 goes from “**hibernation mode**” to “**standby mode**”, ready for “**radio-on**”.

---

**NOTE:** “**Hibernation mode**” is not a function of the RLP40 (model RLP40QE) when it is used with an RMI-QE.

---

## Multiple probe mode (only applicable when RLP40 is used with RMI-Q)

The RLP40 can be configured, using Trigger Logic, to allow multiple radio probes to be used with a single RMI-Q.

Up to four RLP40 probes can be used with a single RMI-Q or in “**radio on / radio off mode**”. For further details of this functionality, refer to the *RMI-Q radio machine interface* installation guide (Renishaw part no. H-5687-8504).

---

### NOTES:

“**Multiple probe mode**” will not appear as an option if the “**radio on**” option has been selected.

RLP40 probes which are set to “**multiple probe mode on**” can coexist alongside any number of RLP40 probes set to “**multiple probe mode off**”.

---

To allow multiple radio probes to work in close proximity, and with a single RMI-Q, 16 choices of “**mode on**” colours are available, each representing a different machine tool installation (for more information, see page 4.3, “**Multiple probe mode settings**”).

All probes operating with a single RMI-Q must be set to the same “**mode on**” colour choice; any multiple probes located on adjacent machines must all be set to an alternative “**mode on**” colour choice.

---

**NOTE:** Each probe per “**mode on**” colour choice must be partnered with the RMI-Q as, by configuring multiple probes to a single “**mode on**” colour choice, all probes using this “**mode on**” colour choice will have the same identity.

---

The probe is partnered after selecting the “**multiple probe mode setting**” and choosing the “**mode on**” option; for more information, see page 4.10, “**Changing the probe settings when using with a RMI-Q**”.

There is no limit to the number of probes that can be used with a single RMI-Q as long as they all have the same “**mode on**” colour choice. All RLP40 probes are factory-set to “**mode off**”.

The addition of any further probe(s), or replacements, into a multi-probe installation can be achieved through the reconfiguration of the probe to the same “**mode on**” colour choice.

---

**NOTE:** “**Multiple probe mode**” does not exist when the RLP40 (model RLP40QE) is used with an RMI-QE.

---

## Partnering mode

System set-up is achieved using Opti-Logic or Trigger Logic and powering-on the RMI-Q or RMI-QE. Alternatively “ReniKey” may be used (see notes below).

Partnering is required during initial system set-up. Further partnering is only required if the RLP40, RMI-Q or RMI-QE is changed.

Partnering to a RMI-Q or RMI-QE will configure the RLP40 to operate in either RMI-Q or RMI-QE mode and display specific probe settings accordingly.

The RLP40 operating mode can be determined by observing the LED check that is displayed when the batteries are inserted into the probe (for more information, see page 4.2, “**Reviewing the probe settings**”). Display of “**Hibernation mode**” or “**Multiple probe mode**” menus also indicates that the RLP40 is in RMI-Q mode.

---

### NOTES:

Prior to partnering for the first time, the RLP40 is pre-set to operate in RMI-QE mode. The LED check will display double flashes of red, green, blue.

Systems using the RMI-Q or RMI-QE can be partnered with up to four RLP40 probes manually. Alternatively, partnering to an RMI-Q or RMI-QE, can be achieved by using ReniKey; a Renishaw machine macro cycle which does not require the RMI-Q or RMI-QE to be power cycled.

For more information or to download ReniKey free of charge visit:

**[www.renishaw.com/mtpsupport/renikey](http://www.renishaw.com/mtpsupport/renikey)**

---

Partnering will not be lost by reconfiguration of probe settings or when changing batteries, except where multiple probe mode is selected.

Partnering can take place anywhere within the operating envelope.

## RLP40 dimensions

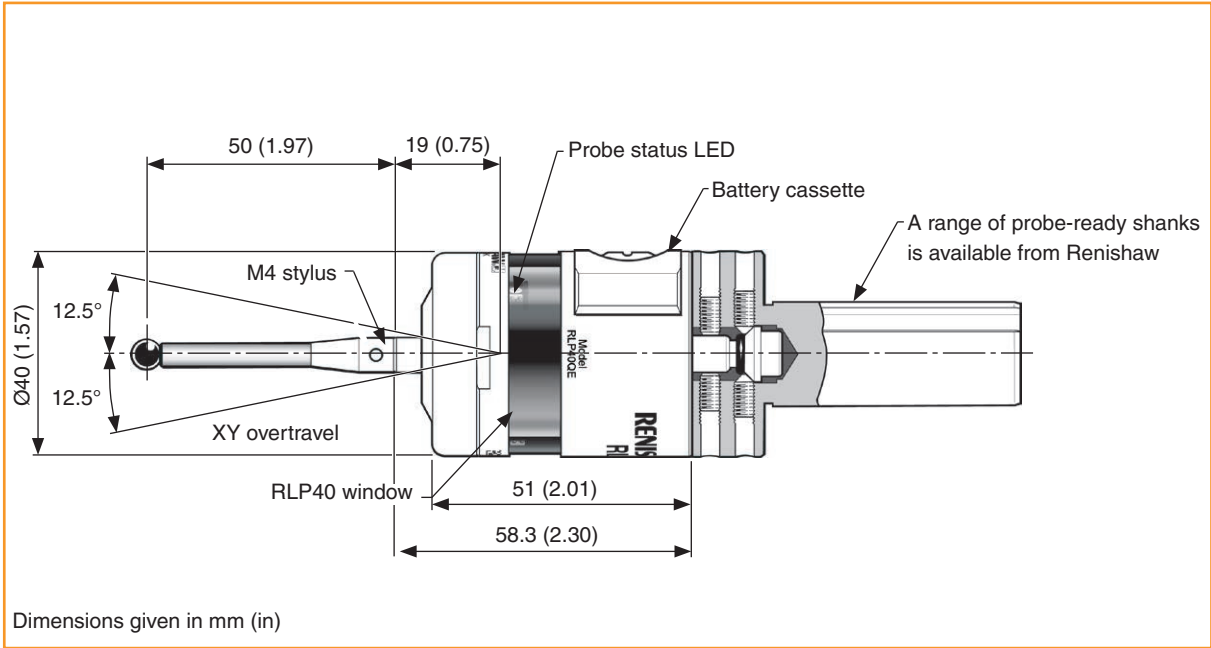

Stylus overtravel limits		
Stylus length	±X/±Y	Z
50 (1.97)	12 (0.47)	6 (0.24)
100 (3.94)	22 (0.87)	6 (0.24)

## RLP40 and RLP40H specification

<b>Principal application</b>	Workpiece inspection and job set-up on multi-tasking machines and lathes.	
<b>Dimensions</b>	Length Diameter	58.3 mm (2.30 in) 40 mm (1.57 in)
<b>Weight (without shank)</b>	With batteries Without batteries	260 g (9.17 oz) 240 g (8.47 oz)
<b>Transmission type</b>	Frequency-hopping spread spectrum (FHSS) radio	
<b>Radio frequency</b>	2400 MHz to 2483.5 MHz	
<b>Switch-on methods</b>	Radio M-code, spin	
<b>Switch-off methods</b>	Radio M-code, spin, timeout	
<b>Spindle speed (maximum)</b>	1000 r/min	
<b>Operating range</b>	Up to 15 m (49.2 ft)	
<b>Receiver/interface</b>	RMI-Q or RMI-QE combined antenna, interface and receiver unit	
<b>Sense directions</b>	Omni-directional $\pm X$ , $\pm Y$ , $+Z$	
<b>Unidirectional repeatability</b> Maximum $2\sigma$ value in any direction	<b>RLP40</b>  1.00 $\mu\text{m}$ (40 $\mu\text{in}$ ) $2\sigma$ <sup>1</sup>	<b>RLP40H</b>  2.00 $\mu\text{m}$ (80 $\mu\text{in}$ ) $2\sigma$ <sup>1</sup>
<b>Stylus trigger force</b> <sup>2 3</sup> XY low force XY high force Z	0.60 N, 61 gf (2.15 ozf) 0.97 N, 99 gf (3.49 ozf) 6.23 N, 635 gf (22.41 ozf)	1.58 N, 161 gf (5.68 ozf) 3.17 N, 323 gf (11.40 ozf) 10.62 N, 1083 gf (38.20 ozf)
Maximum setting: XY low force XY high force Z	0.83 N, 85 gf (2.99 ozf) 1.60 N, 163 gf (5.76 ozf) 10.00 N, 1020 gf (35.97 ozf)	Not applicable
Minimum setting: XY low force XY high force Z	0.30 N, 31 gf (1.08 ozf) 0.60 N, 61 gf (2.16 ozf) 4.00 N, 408 gf (14.39 ozf)	Not applicable
<b>Stylus overtravel</b> XY plane $+Z$ plane	$\pm 12.5^\circ$ 6 mm (0.24 in)	$\pm 12.0^\circ$ 5 mm (0.20 in)

- 1 Performance specification is tested at a standard test velocity of 480 mm/min (18.9 in/min) with a 50 mm stylus. Significantly higher velocity is possible depending on application requirements.
- 2 Trigger force, which is critical in some applications, is the force exerted on the component by the stylus when the probe triggers. The maximum force applied will occur after the trigger point (overtravel). The force value depends on related variables including measuring speed, machine deceleration and system latency.
- 3 These are the factory settings; manual adjustment is not possible on the RLP40H.

<b>Environment</b>	IP rating	IPX8, BS EN 60529:1992+A2:2013 (IEC 60529:1989+A1:1999+A2:2013)
	IK rating	IK02 (BS EN IEC 62262: 2002) [for glass window]
	Storage temperature	-25 °C to +70 °C (-13 °F to +158 °F)
	Operating temperature	+5 °C to +55 °C (+41 °F to +131 °F)
<b>Battery types</b>	2 × ½AA 3.6 V lithium-thionyl chloride (LTC)	
<b>Battery reserve life</b>	Approximately one week after a low battery warning is first given (based on 5% usage)	
<b>Low battery indication</b>	Blue flashing LED in conjunction with normal red or green probe status LED	
<b>Dead battery indication</b>	Constant or flashing red	
<b>Typical battery life</b>	See the table below	

### Typical battery life

Typical battery type		2 × ½AA 3.6 V LTC		
Typical battery life		Radio on		Spin on
		(1 s turn-on)	(0.5 s turn-on)	
	Standby life	82 months	44 months	46 months
	Light usage 1%	67 months	40 months	40 months
	Heavy usage 5%	39 months	28 months	28 months
	Continuous use	2560 hours	2560 hours	2440 hours

**NOTES:**

Battery life figures quoted in the above table are applicable to the RLP40 (model RLP40QE) when used in conjunction with an RMI-QE interface/receiver. Using with an RMI-Q interface/receiver will result in a reduction from the figures quoted.

1% usage = 14 minutes/day.

5% usage = 72 minutes/day.

Battery life is dependent on the quality of the external RF environment in which the probing system is operating.

# System installation

## Installing the RLP40 with an RMI-Q or RMI-QE

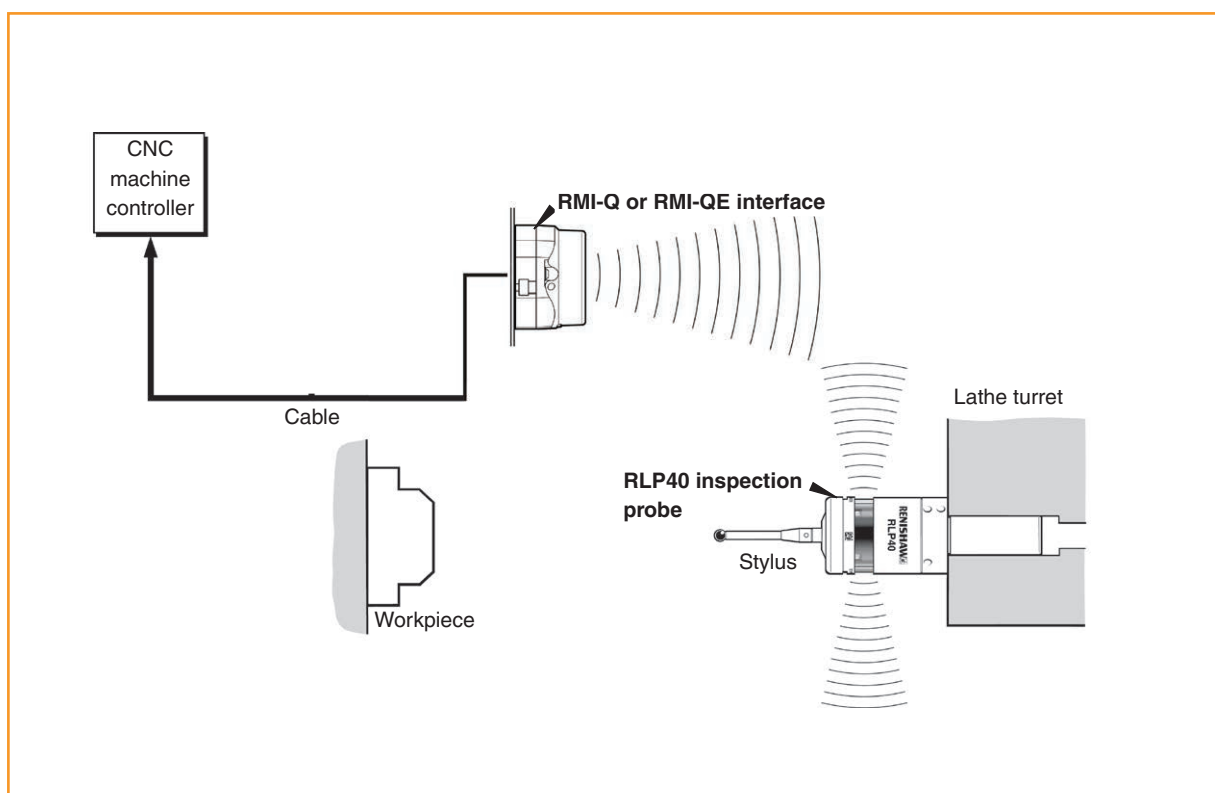

### Operating envelope

Radio transmission does not require line-of-sight between the probe and interface as it works via reflected paths, and will pass through very small gaps and machine tool windows. This allows easy installation inside the machine.

Coolant and swarf residue accumulating on the RLP40 and RMI-Q or RMI-QE may have a detrimental effect on transmission performance. Wipe clean as often as is necessary to maintain unrestricted transmission.

When operating, do not cover the probe glass window, RMI-Q, or RMI-QE with your hands, as this will affect the performance.

## Positioning the RLP40 and RMI-Q or RMI-QE

The probe system should be positioned so that the optimum range can be achieved over the full travel of the machine's axes. Always face the front cover of the RMI-Q or RMI-QE in the general direction of the machining area and the tool magazine, ensuring both are within the performance envelope shown below. To assist in finding the optimum position of the RMI-Q or RMI-QE, the signal quality is displayed on an RMI-Q or RMI-QE signal LED.

### NOTES:

#### Installing the RLP40 and RMI-Q or RMI-QE

The RLP40 has a built-in “**hibernation mode**” (battery-saving mode) that saves battery life when the RMI-Q is unpowered in “**radio-on**” (“**radio-off**” or “**timer-off**”) configurations. The RLP40 goes into “**hibernation mode**” 30 seconds after the RMI-Q is unpowered (or the RLP40 is out of range). When in “**hibernation mode**”, the RLP40 checks for a powered RMI-Q every 30 seconds. If found, the RLP40 goes from “**hibernation mode**” to “**standby mode**”, ready for “**radio-on**”.

“**Hibernation mode**” does not exist when the RLP40 (model RLP40QE) is used with an RMI-QE.

### Performance envelope

The RLP40 and RMI-Q or RMI-QE must be within each other's performance envelope, as shown below. The performance envelope shows line-of-sight performance, however, this is not necessary for the RLP40 radio transmission as it will operate with any reflected radio path provided that the reflected path length does not exceed the 15 m (49.2 ft) operating range.

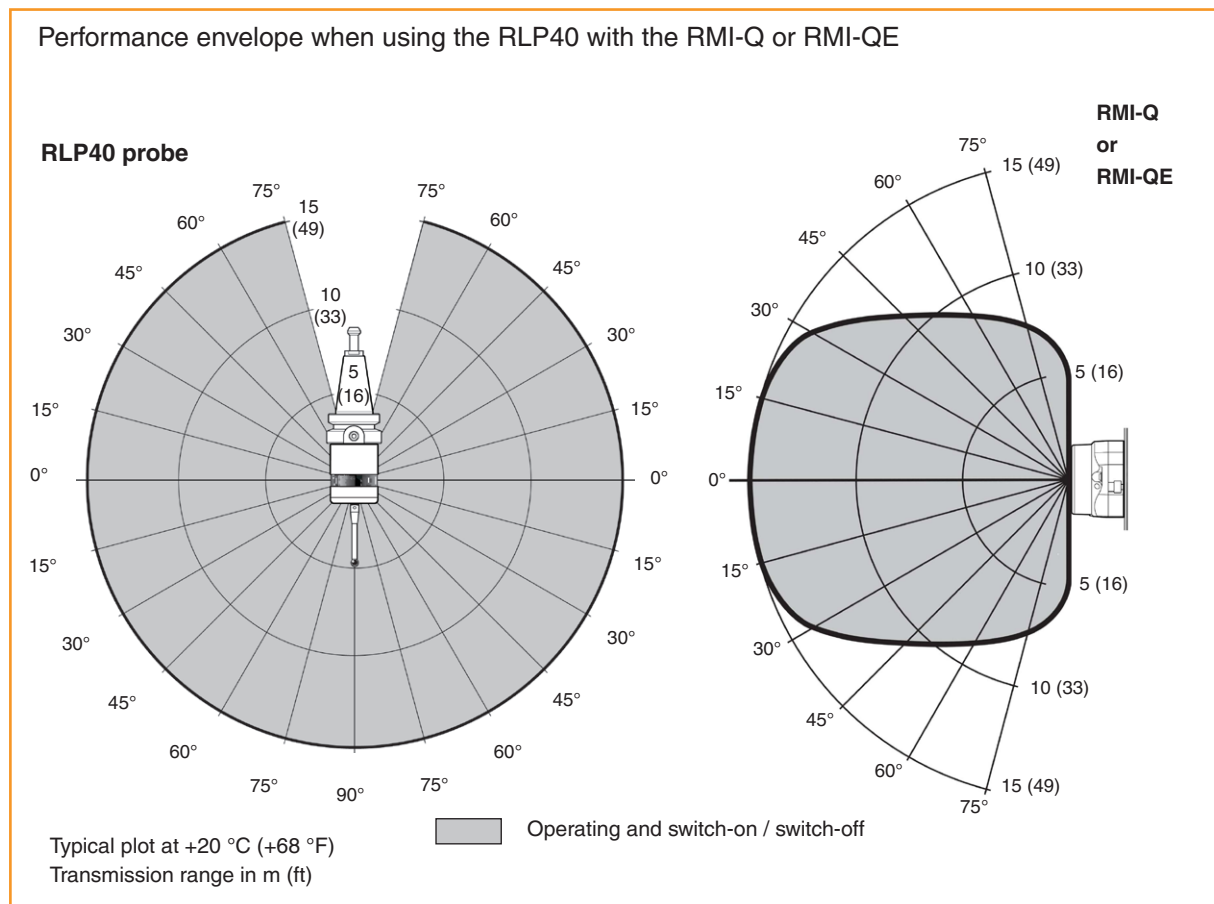



## Preparing the RLP40 for use

### Fitting the stylus

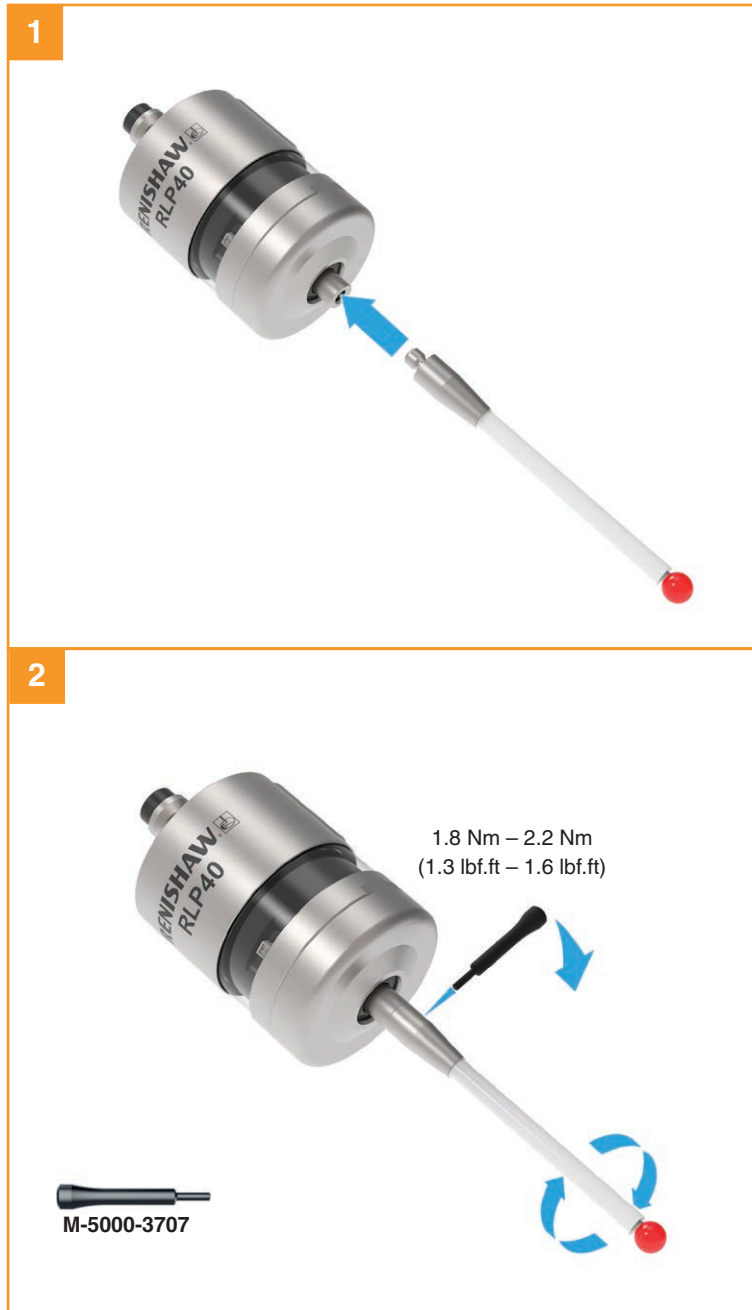

## Installing the batteries

### NOTES:

See Section 5, “**Maintenance**” for a list of suitable battery types.

If dead batteries are inadvertently inserted, the LEDs will remain a constant red.

Do not allow coolant or debris to enter the battery compartment. When inserting batteries, check that the battery polarity is correct.

After the batteries have been inserted, the LEDs will display the current probe settings (see page 4.2, “**Reviewing the probe settings**”, for further information).



## Mounting the probe on a shank

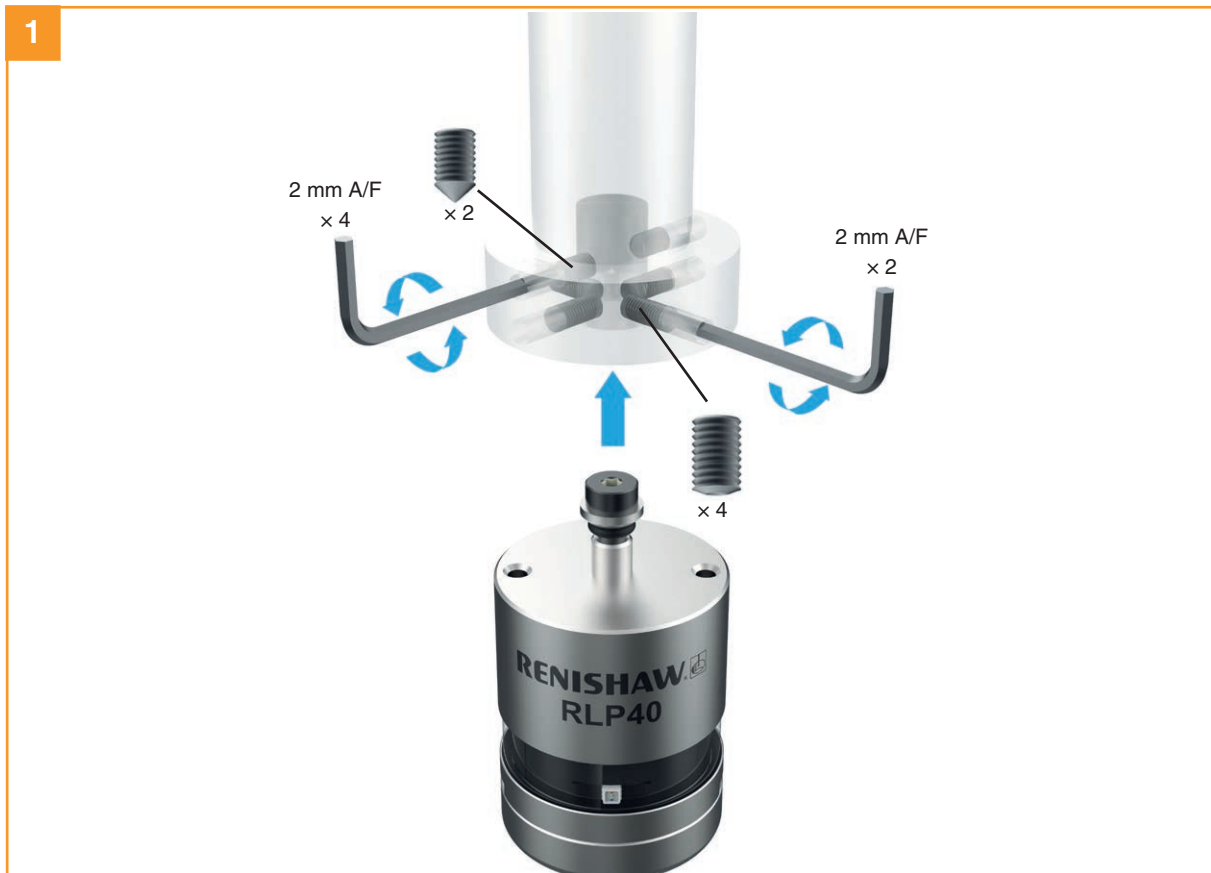

## Stylus on-centre adjustment

### NOTES:

If a probe and shank assembly is dropped, it must be rechecked for correct on-centre adjustment.

Do not hit or tap the probe to achieve on-centre adjustment.

1

Adjust in X axis

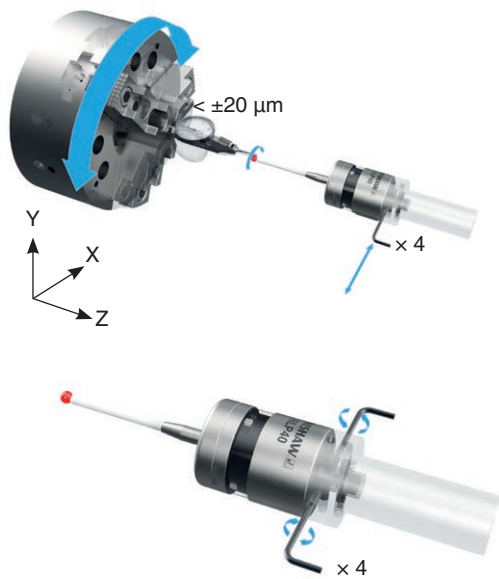

2

Adjust in Y axis

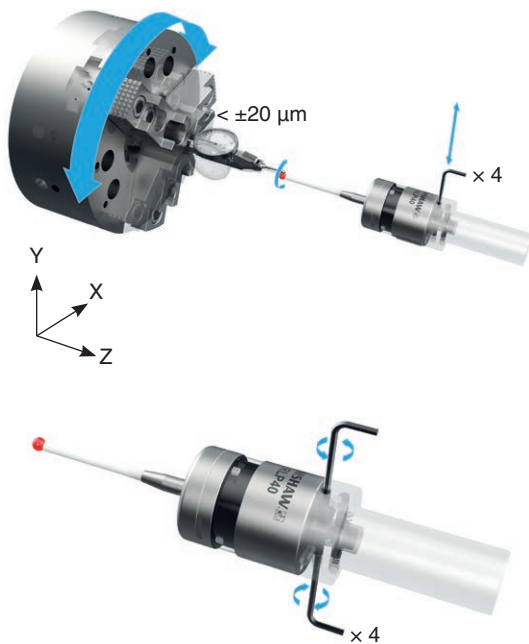

3

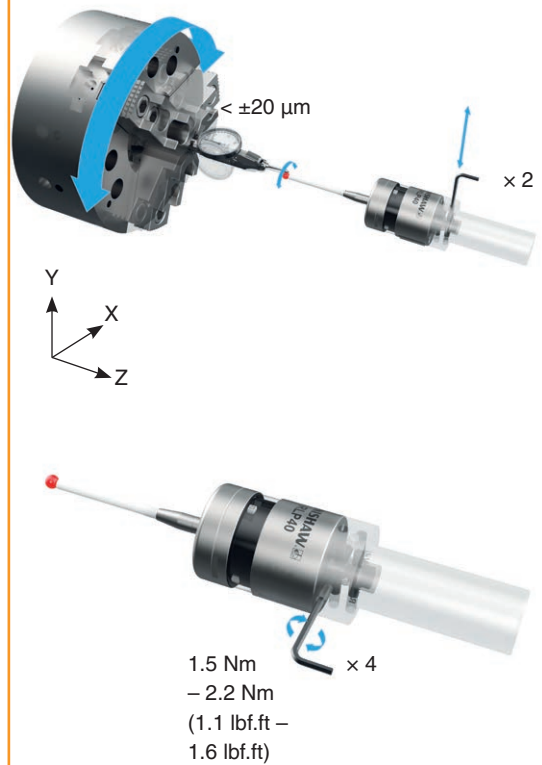

## Stylus trigger force and adjustment (RLP40 only)

Spring force within the probe causes the stylus to sit in a unique position and return to this position following each stylus deflection.

Stylus trigger force is set by Renishaw, but can be adjusted by the user in special circumstances (for example where there is excessive machine vibration or insufficient force to support the stylus weight, that results in a deflection of the stylus without contacting a part).

To adjust the trigger force, turn the adjusting screw anticlockwise (as shown) to reduce the force (more sensitive); eventually it reaches a stop. Turn the adjusting screw clockwise (as shown) to increase the force (less sensitive). If the internal screw becomes disengaged, remove any pressure on the stylus and turn the key anticlockwise to re-engage the thread.

Trigger forces in the XY plane vary around the stylus and depend on trigger direction.

Stylus trigger force adjustment and use of styli other than test stylus types may cause probe repeatability to differ from the calibration certificate results.

### Factory setting

#### RLP40

XY low force	0.60 N, 61 gf (2.15 ozf)
XY high force	0.97 N, 99 gf (3.49 ozf)
Z	6.23 N, 635 gf (22.41 ozf)

#### Maximum setting

XY low force	0.83 N, 85 gf (2.99 ozf)
XY high force	1.60 N, 163 gf (5.76 ozf)
Z	10.00 N, 1020 gf (35.97 ozf)

#### Minimum setting

XY low force	0.30 N, 31 gf (1.08 ozf)
XY high force	0.60 N, 61 gf (2.16 ozf)
Z	4.00 N, 408 gf (14.39 ozf)

---

**NOTE:** The RLP40H does not have trigger force adjustment.

---



## Calibrating the RLP40

### Why calibrate a probe?

A spindle probe is just one component of the measurement system which communicates with the machine tool. Each part of the system can introduce a constant difference between the position that the stylus touches and the position that is reported to the machine. If the probe is not calibrated, this difference will appear as an inaccuracy in the measurement. Calibration of the probe allows the probing software to compensate for this difference.

During normal use, the difference between the touch position and the reported position does not change, but it is important that the probe is calibrated in the following circumstances:

- When a probe system is to be used for the first time.
- When the trigger filter is changed.
- When a new stylus is fitted to the probe.
- When it is suspected that the stylus has become distorted or that the probe has been crashed.
- At regular intervals to compensate for mechanical changes of your machine tool.
- If repeatability of relocation of the probe shank is poor. In this case, the probe may need to be recalibrated each time it is selected.

It is good practice to set the tip of the stylus on-centre, because this reduces the effect of any variation in spindle and tool orientation (see page 3.6, “**Stylus on-centre adjustment**”, for further information). A small amount of run-out is acceptable, and can be compensated for as part of the normal calibration process.

Three different operations are to be used when calibrating a probe. They are:

- Calibrating either in a bored hole or on a turned diameter of known position.
- Calibrating either in a ring gauge or on a datum sphere;
- Calibrating the probe length.

### Calibrating in a bored hole or on a turned diameter

Calibrating a probe, either in a bored hole or on a turned diameter of known size, automatically stores values for the offset of the stylus ball to the spindle centre line. The stored values are then used automatically in the measuring cycles. Measured values are compensated by these values so that they are relative to the true spindle centre line.

### Calibrating in a ring gauge or on a datum sphere

Calibrating a probe either in a ring gauge or on a datum sphere with a known diameter automatically stores one or more value for the radius of the stylus ball. The stored values are then used automatically by the measuring cycles to give the true size of the feature. The values are also used to give true positions of single surface features.

---

**NOTE:** The stored radius values are based on the true electronic trigger points. These values are different from the physical sizes.

---

## Calibrating the probe length

Calibrating a probe on a known reference surface determines the length of the probe, based on the electronic trigger point. The stored value for length is different from the physical length of the probe assembly. Additionally, the operation can automatically compensate for machine and fixture height errors by adjusting the probe length value that is stored.

This page is intentionally left blank.



# Probe configuration

## Configuring the probe using the Probe Setup app

The Probe Setup app simplifies the process of configuring Renishaw machine tool probes compatible with Opti-Logic™ or Trigger Logic™.

The app provides clear, step-by-step, visual instructions and video tutorials to guide a user through the process of setting up and configuring a Renishaw machine tool probing system.

### Using Opti-Logic™

Opti-Logic™ is the process of transmitting and receiving data from the app to a Renishaw machine tool probe using pulses of light. The app will ask for the probe version to be entered. The probe version is displayed at the back of the battery compartment which is visible when the battery cassette is removed.

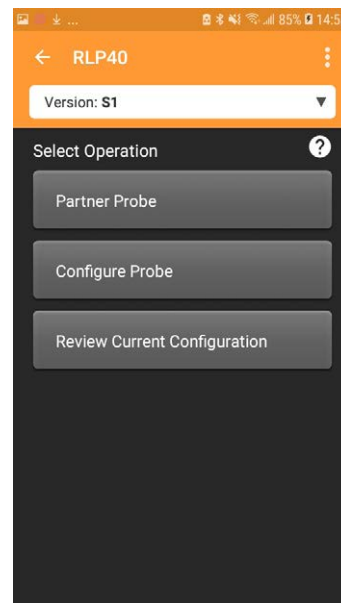
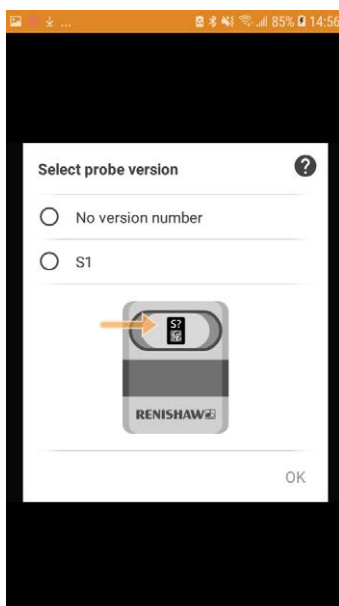

The Probe Setup app is available for download on the App Store and Google Play and several app stores in China.



## Reviewing the probe settings

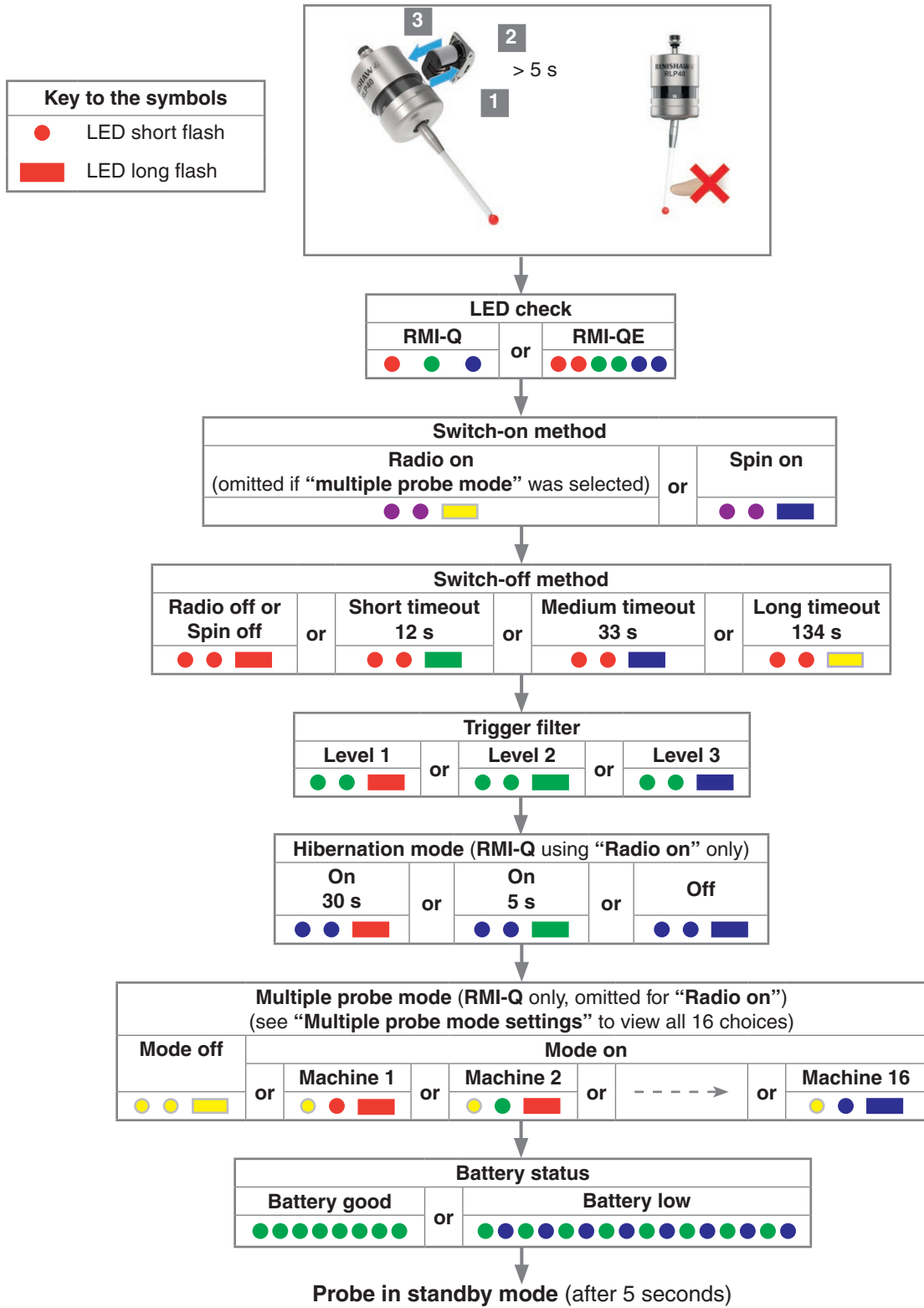

## Multiple probe mode settings

(RMI-Q application only)

Deflect the stylus for less than 4 seconds to cycle to the next setting.

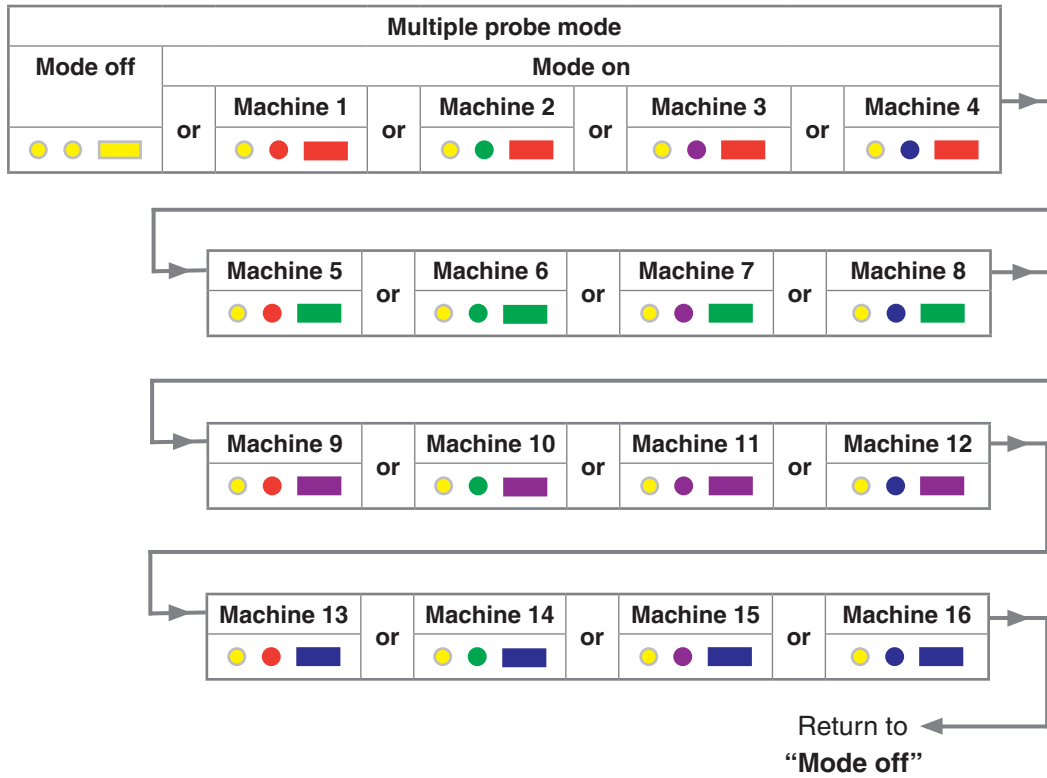

## Probe settings record

This page is provided to note your probe's settings.

			✓ tick	
			Factory settings	New settings
<b>Switch-on method</b>	Radio on		✓	
	Spin on			
<b>Switch-off method</b>	Radio or spin		✓	
	Short timeout (12 s)			
	Medium timeout (33 s)			
	Long timeout (134 s)			
<b>Trigger filter</b>	Level 1		✓	
	Level 2			
	Level 3			
<b>Hibernation mode setting (RMI-Q only)</b>	On (30 s)		✓	
	On (5 s)			
	Off			
<b>Multiple probe mode (RMI-Q only)</b>	Off (factory set)		✓	
	On (machine number)	See <b>“Multiple probe settings”</b>		

Factory settings are for kit (A-6717-0001) only.

RLP40 serial no .....

## Probe partnering function

The probe partnering function enables the RLP40 to be partnered with an RMI-Q or RMI-QE interface independently of the configuration process for other probe settings. To partner the RLP40 with an RMI-Q or RMI-QE, insert the batteries or, if they have already been installed, remove them for 5 seconds and then refit them.

Following the LED check, the RLP40 will proceed to show the probe settings. This will end with **“Battery status”** being displayed. If the battery power is good, battery status will be eight green flashes. If battery power is low, each green flash will be followed by a blue flash.

Whilst the **“Battery status”** is being displayed, deflect and immediately release the stylus to enter **“Partnering mode”**.

**“Partnering mode off”** will be displayed as a sequence of light blue flashes. At this point the RMI-Q or RMI-QE must be turned on.

If a RMI-Q is turned on, the RLP40 will continue to display the sequence of light blue flashes. If a RMI-QE is turned on, the RLP40 display sequence will now incorporate a long yellow flash.

On the RLP40 select **“Partnering mode on”** by deflecting the stylus for less than 4 seconds. After successful partnering indicated by a light blue, light blue, green flash, the RLP40 will timeout after 20 seconds and then go into standby. If **“Partnering mode on”** is not selected, the RLP40 will timeout after 120 seconds and then go into standby (see page 4.7, **“RLP40 – RMI-Q partnership”**, or page 4.8, **“RLP40 – RMI-QE partnership”**, for further information).

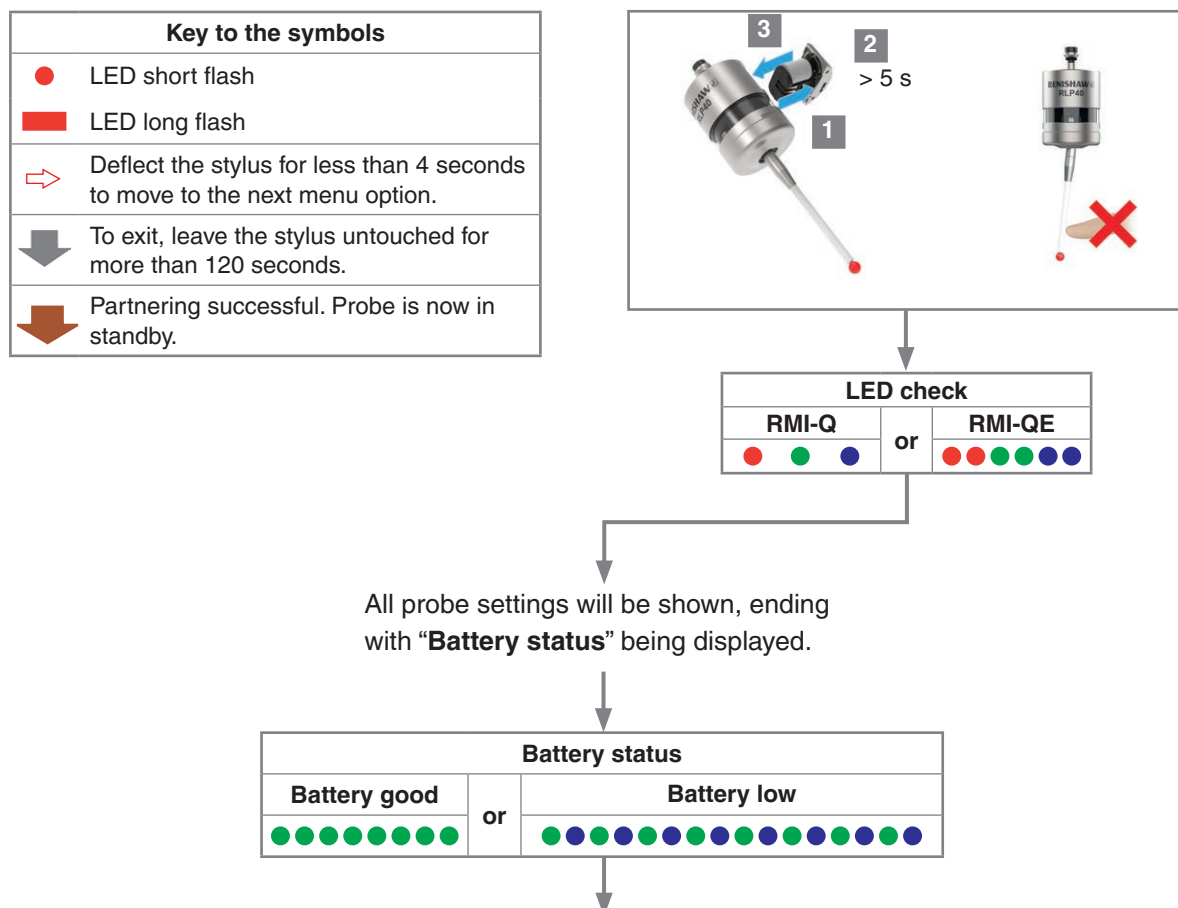

Whilst the “**Battery status**” is being displayed, deflect and release the stylus to enter “**Partnering mode**”. Probe status will flash red to acknowledge this.

**NOTE:** Wait until the first battery status flash has occurred before deflecting the stylus, and then release the stylus when the red flash is observed. Ensure this is done before the last battery status flash is displayed.

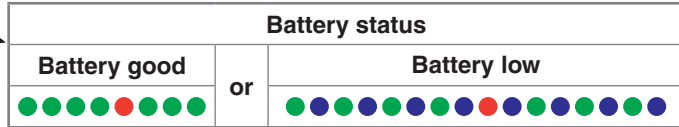

At this point turn on either the RMI-Q or RMI-QE.

**With RMI-Q switched on**

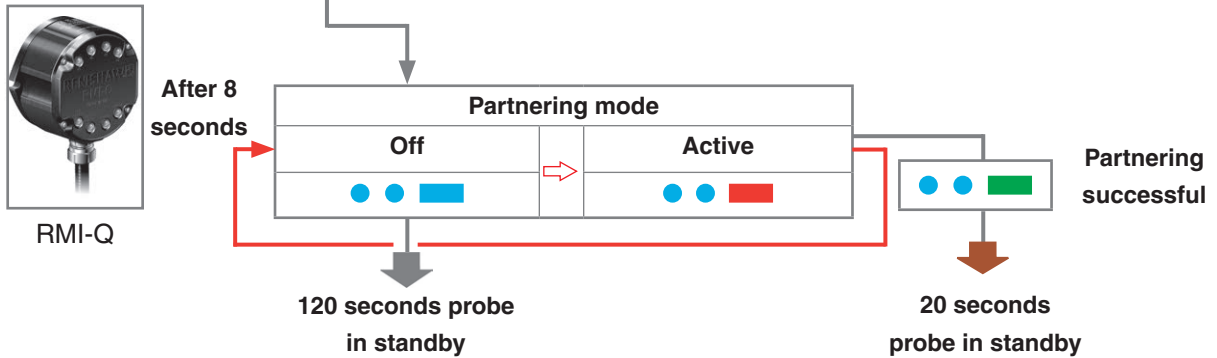

If partnering is unsuccessful “**Partnering mode off**” will be displayed again after 8 seconds. Deflect the stylus for less than 4 seconds to select “**Partnering mode active**” again.

or

**With RMI-QE switched on**

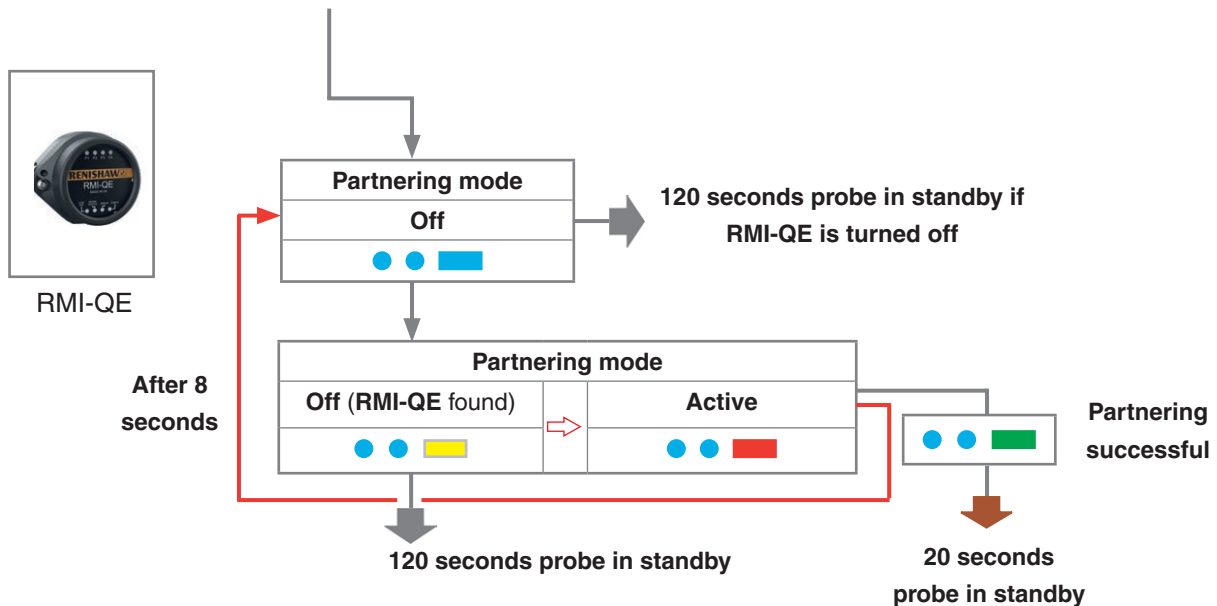

If partnering is unsuccessful “**Partnering mode off**” will be displayed again after 8 seconds. When “**Partnering mode off (RMI-QE found)**” is displayed, deflect the stylus for less than 4 seconds to select “**Partnering mode active**” again.

## RLP40 – RMI-Q partnership

System set-up is achieved by using Trigger Logic™ and powering on the RMI-Q. Alternatively, partnering to an RMI-Q can be achieved by using ReniKey; a Renishaw machine macro cycle which does not require the RMI-Q to be power cycled.

Partnering is required during initial system set-up. Further partnering will be required if either the RLP40 or RMI-Q is changed.

Partnering will not be lost by reconfiguring the probe settings or changing the batteries. Partnering can take place anywhere within the operating envelope.

The RLP40 should be operated with only one partnered RMI-Q being active (powered).

In configuration mode, configure the probe settings as required until you reach the “Partnering mode” menu, which defaults to “Partnering mode off”.

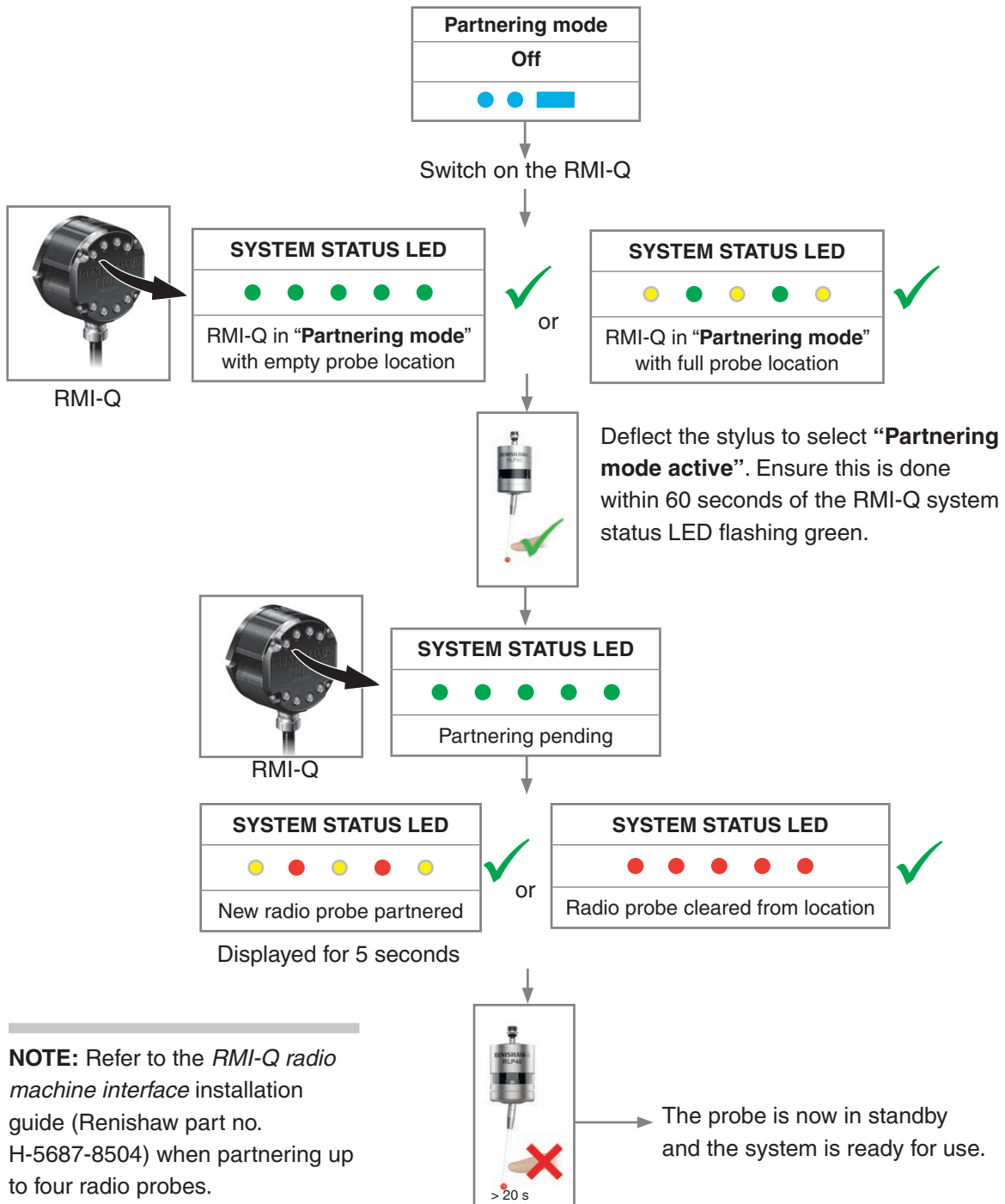

**NOTE:** Refer to the *RMI-Q radio machine interface* installation guide (Renishaw part no. H-5687-8504) when partnering up to four radio probes.

## RLP40 – RMI-QE partnership

System set-up is achieved by using Trigger Logic™ and powering on the RMI-QE. Alternatively, partnering to a RMI-QE can be achieved by using ReniKey; a Renishaw machine macro cycle which does not require the RMI-QE to be power cycled.

Partnering is required during initial system set-up. Further partnering will be required if either the RLP40 or RMI-QE is changed.

Partnering will not be lost by reconfiguring the probe settings or changing the batteries. Partnering can take place anywhere within the operating envelope.

An RLP40 that is partnered with the RMI-QE but then used with another system will need to be repartnered before being used again with the RMI-QE.

See page 4.5, “**Probe partnering function**”, for further information on how to reach “**Partnering mode**”.

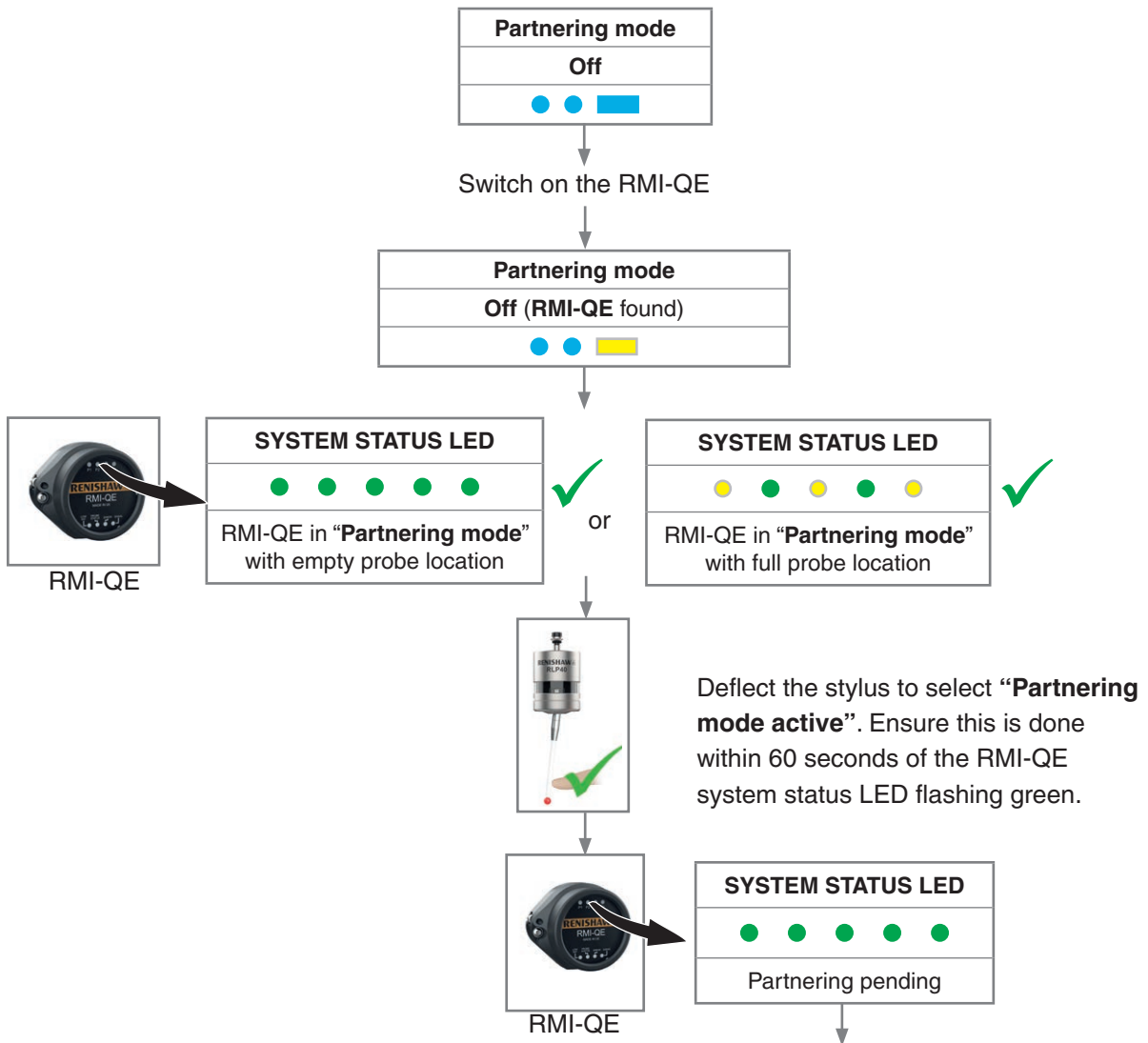



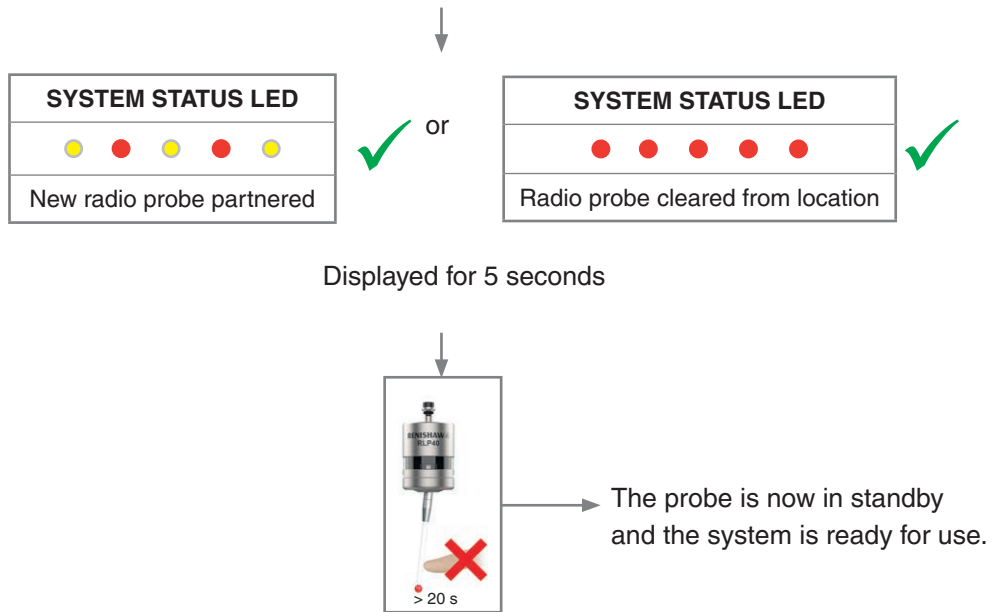

---

**NOTE:** Refer to the *RMI-QE radio machine interface* installation guide (Renishaw part no. H-6551-8520) when partnering up to four radio probes.

---



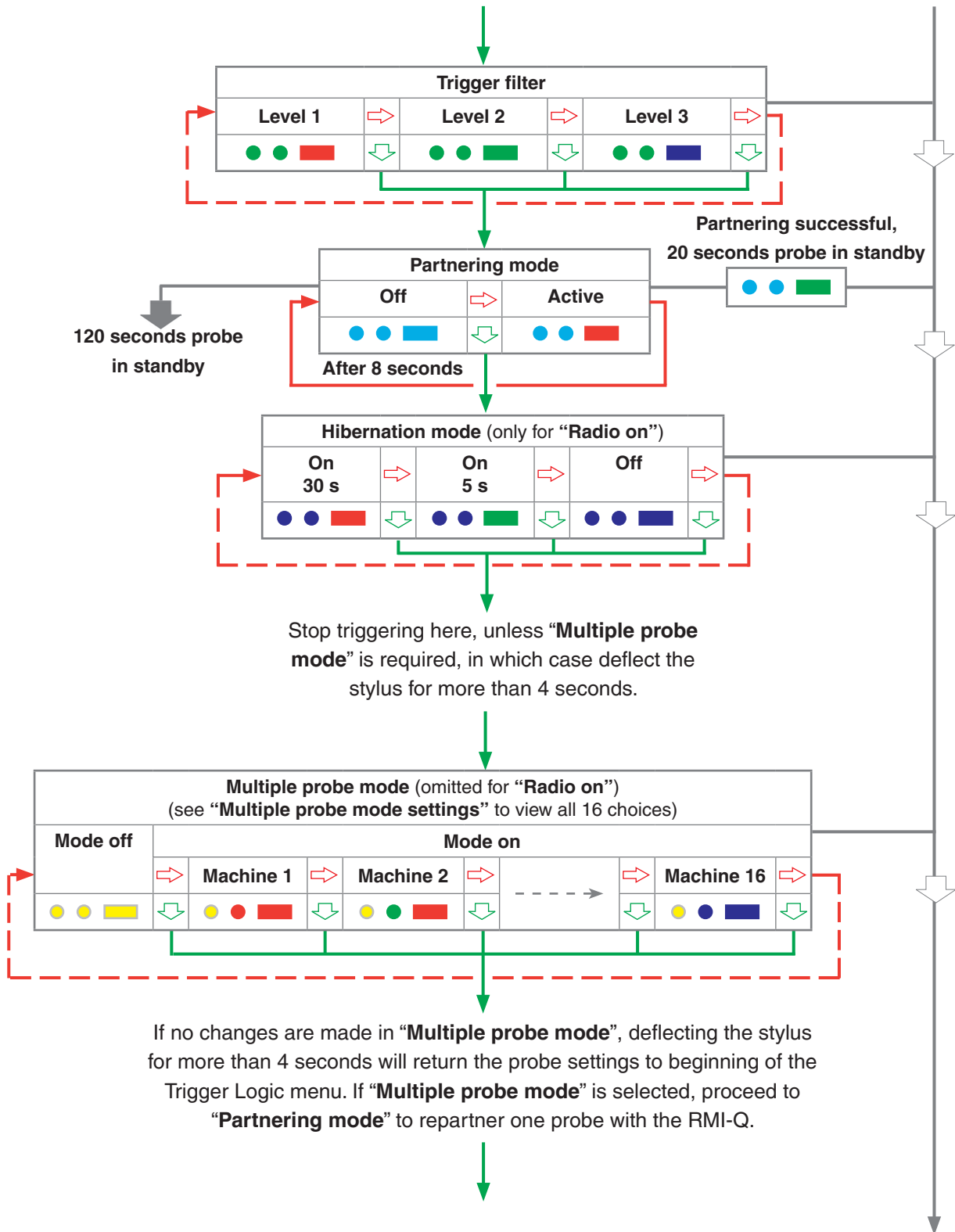

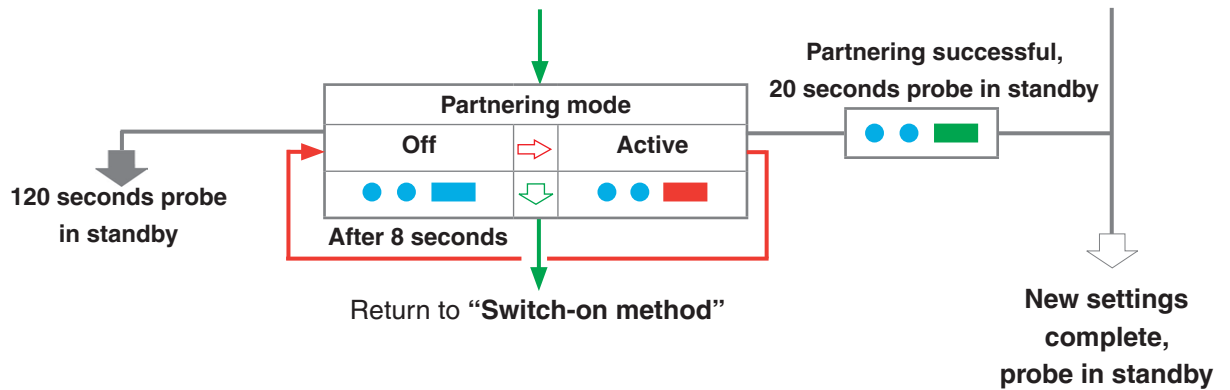

---

**NOTES:**

If using **"Multiple probe mode"**, refer to the *RMI-Q radio machine interface* installation guide (Renishaw part no. H-5687-8504).

Further probes used require the same "Multiple probe mode" setting, but do not need to be partnered with the RMI-Q.

To partner an RLP40 with an RMI-Q, see page 4.7, **"RLP40 – RMI-Q partnership"**, for further information. Once partnering has been successful, the RLP40 will display **"Partnering successful"** and go into standby after 20 seconds.

---

## Changing the probe settings when partnered to an RMI-QE

Probe settings can be changed using Trigger Logic. Insert the batteries or, if they have already been installed, remove them for 5 seconds and then refit them.

Following the LED check, immediately deflect the stylus and hold it deflected until eight red flashes have been observed (if the battery power is low, each red flash will be followed by a blue flash).

Keep the stylus deflected until the “**Switch-on method**” setting is displayed, then release it.

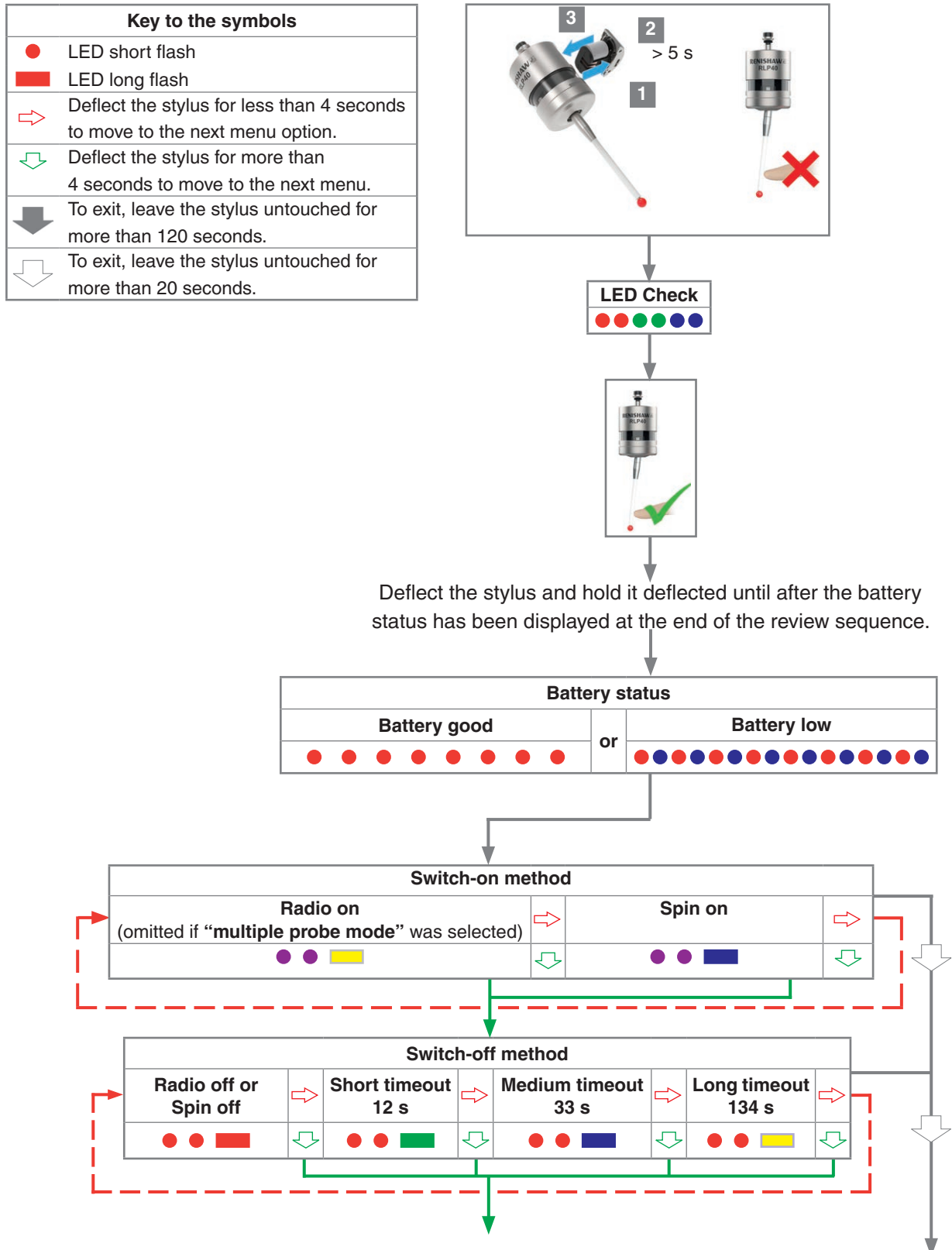

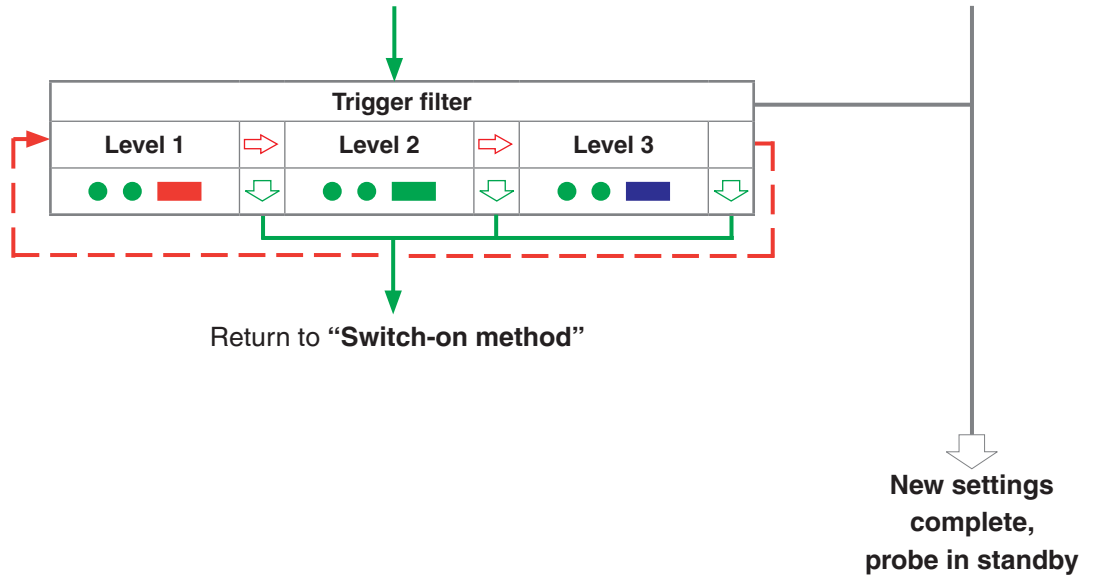

---

**NOTE:** To partner an RLP40 with an RMI-QE, see page 4.5 “**Probe partnering function**” for further information on how to reach “**Partnering mode**”.

---

## Master reset function

RLP40 features a master reset function to assist users who have mistakenly changed the probe settings into an unintended state.

The application of the master reset function will clear all current probe settings and return the probe to default settings.

The default settings are as follows:

- Radio switch-on
- Radio switch-off
- Trigger filter: Level 1
- Hibernation mode on 30 s
- Multiple probe mode off

The default settings may not be representative of the required probe settings. Further configuration of the RLP40 may subsequently be necessary to achieve the required probe settings.

### To reset the probe

1. Insert the batteries or, if they have already been installed, remove them for 5 seconds and then refit them.
2. Following the LED check, immediately deflect the stylus and hold it deflected until eight red flashes have been observed (if the battery power is low, each red flash will be followed by a blue flash).
3. Keep the stylus deflected until the “**Switch-on method**” setting is (or first Trigger Logic menu) displayed, then release it.
4. Deflect the stylus for 20 seconds. The status LEDs will flash yellow eight times. A confirmation for master reset is required; if no action is taken, the probe will time out.
5. To confirm that a master reset is required, release the stylus and then hold the stylus deflected again until the eight yellow flash sequence has ended. This action clears all probe settings and returns the probe to default settings. Following an LED, check the RLP40 returns to Trigger Logic and displays “**Switch-on method**”.
6. Further configuration using Trigger Logic may be necessary to achieve the required probe settings.

1.

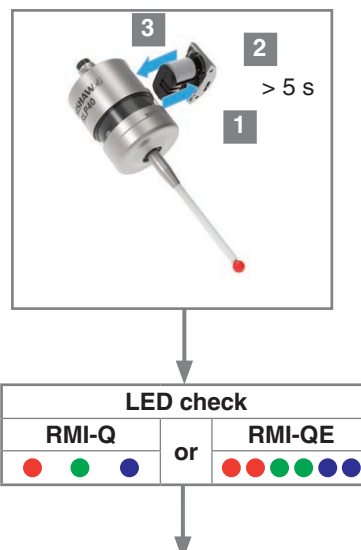

2.



Battery status		
Battery good	or	Battery low
● ● ● ● ● ● ● ●		● ● ● ● ● ● ● ● ● ● ● ● ● ● ● ● ● ●

3.

Switch-on method		
Radio on (omitted if "multiple probe mode" was selected)	or	Spin on
● ● ●		● ● ●



Release the stylus.

4.



Deflect the stylus for 20 seconds until the status LEDs start to flash yellow eight times.

5.



Whilst the status LEDs are flashing yellow to confirm that a master reset is required, release the stylus and then hold the stylus deflected again until the eight yellow flash sequence has ended.

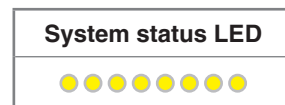

Previous settings have been cleared. The probe now has default settings.





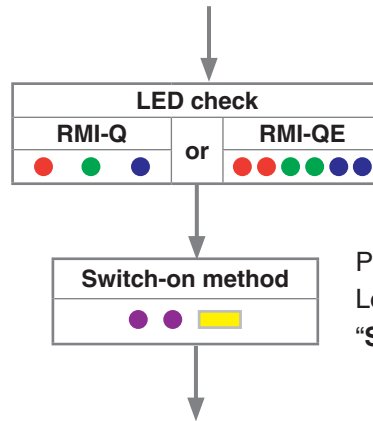

Probe is now back in the Trigger Logic menu and will display "Switch-on method".

6.

Configure probe settings as required using Trigger Logic

---

**NOTE:** The RLP40 will continue to be partnered with either the RMI-Q or RMI-QE following the activation of the master reset function.

---

## Operating mode

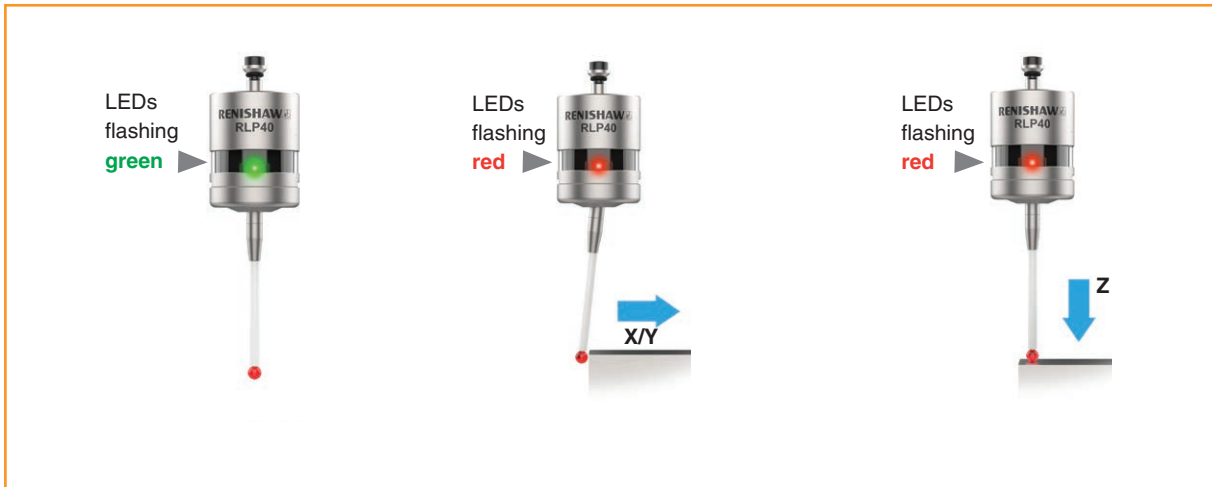

### Probe status LEDs

LED colour	Probe status	Graphic hint
Flashing green	Probe seated in operating mode	● ● ●
Flashing red	Probe triggered in operating mode	● ● ●
Flashing green and blue	Probe seated in operating mode – low battery	● ● ● ● ● ●
Flashing red and blue	Probe triggered in operating mode – low battery	● ● ● ● ● ●
Constant red	Battery dead	■
Flashing red or Flashing red and green or Sequence when batteries are inserted	Unsuitable battery	● ● ● ● ● ● ● ● ● ● ● ● ● ● ● ● ● ●

**NOTE:** Due to the nature of lithium-thionyl chloride batteries, if a “low battery” LED warning is ignored, it is possible for the following sequence of events to occur:

1. When the probe is active, the batteries discharge until battery power becomes too low for the probe to operate correctly.
2. The probe stops functioning, then reactivates as the batteries recover sufficiently to provide the probe with power.
3. The probe begins to run through the LED review sequence (see page 4.2, “**Reviewing the probe settings**”, for further information).
4. Again, the batteries discharge and the probe ceases to function.
5. Again, the batteries recover sufficiently to provide the probe with power, and the sequence repeats itself.

# Maintenance

5.1

## Maintenance

You may undertake the maintenance routines described in these instructions.

Further dismantling and repair of Renishaw equipment is a highly specialised operation, which must be carried out at an authorised Renishaw Service Centre.

Equipment requiring repair, overhaul or attention under warranty should be returned to your supplier.

## Cleaning the probe

Wipe the window of the probe with a clean cloth to remove machining residue. This should be done on a regular basis to maintain optimum transmission.

---

**CAUTION:** The RLP40 has a glass window. Handle with care if broken to avoid injury.

---



## Changing the batteries

---

### CAUTIONS:

Do not leave dead batteries in the probe.

When changing batteries, do not allow coolant or debris to enter the battery compartment.

When changing batteries, check that the battery polarity is correct.

Take care to avoid damaging the battery cassette gasket.

Only use specified batteries.

---



**CAUTION:** Dispose of dead batteries in accordance with local regulations. Never dispose of batteries in a fire.

---





**NOTES:**

After removing the old batteries, wait more than 5 seconds before inserting the new batteries.

Do not mix new and used batteries or battery types, as this will result in reduced life and damage to the batteries.

Always ensure that the cassette gasket and mating surfaces are clean and free from dirt before reassembly.

If dead batteries are inadvertently inserted, the LEDs will remain a constant red.

Battery type					
½ AA lithium-thionyl chloride (3.6 V) × 2					
✓	<b>Saft:</b>	LS 14250	✗	<b>Dubilier:</b>	SB-AA02
	<b>Tadiran:</b>	SL-750		<b>Maxell:</b>	ER3S
	<b>Xeno:</b>	XL-050F		<b>Sanyo:</b>	CR 14250SE
				<b>Tadiran:</b>	SL-350, SL-550, TL-4902, TL-5902, TL-2150, TL-5101
			<b>Varta:</b>	CR ½AA	

**NOTE:** Lithium-thionyl chloride batteries are available from other manufacturers. However, these are untested by Renishaw so correct operation of the probe cannot be guaranteed.

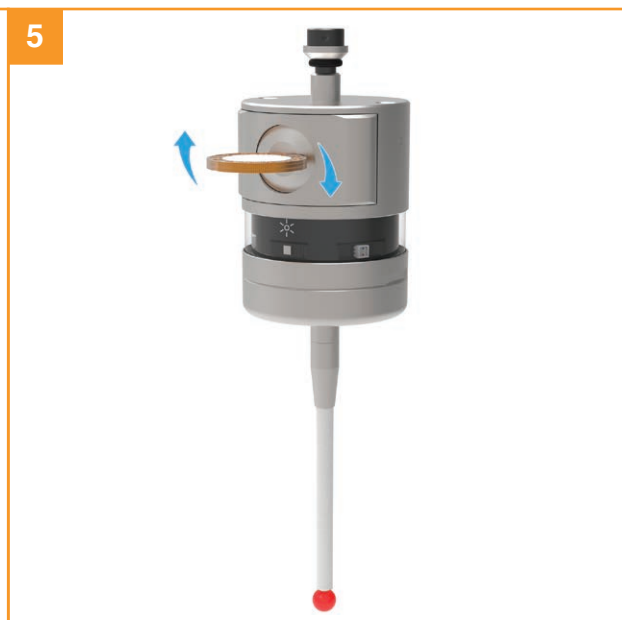

## RLP40 eyelid

The RLP40 is fitted with a metal eyelid that protects the internal components of the probe from hot chip and coolant environment. Dirt may accumulate in the cavity underneath the metal eyelid seal.

To remove this dirt, once a month, remove the front cap (using a coin or flat blade screwdriver) and then remove all the residue with a low-pressure jet of coolant.

Do not use a sharp tool or a degreasing agent. The cleaning interval may be extended or reduced, depending on the rate dirt accumulates. If the inner diaphragm is damaged, return the probe to your supplier for repair.

### Reassembling the probe

Do not use the probe with the cap removed. Check that the probe is firmly secured in its mounting.



# Fault-finding

Symptom	Cause	Action
<b>The probe fails to power up (no LEDs illuminated or fails to indicate current probe settings).</b>	Dead batteries.	Change batteries.
	Unsuitable batteries.	Fit suitable batteries.
	Batteries inserted incorrectly.	Check battery insertion/polarity.
	Batteries removed for too short a time and probe has not reset.	Remove batteries for a minimum of 5 seconds.
	Poor connection between battery cassette mating surfaces and contacts.	Remove any dirt and clean the contacts before reassembly.
<b>The probe fails to switch on.</b>	Dead batteries.	Change batteries.
	Batteries inserted incorrectly.	Check battery insertion/polarity.
	Probe out of range.	Check position of RMI-Q or RMI-QE; see operating envelope.
	No RMI-Q or RMI-QE “start/stop” signal (“ <b>radio on mode</b> ” only).	Check RMI-Q or RMI-QE for green start LED.
	Incorrect spin speed (“ <b>spin on mode</b> ” only).	Check spin speed and duration.
	Incorrect “ <b>switch on mode</b> ” configured.	Check configuration and alter as required.
	Incorrect “ <b>multiple probe mode</b> ” setting configured (RMI-Q only).	Check configuration and alter as required.
	RLP40 in “ <b>hibernation mode</b> ” (RMI-Q and “ <b>radio on</b> ” method only).	Ensure probe is in range and wait up to 30 seconds, then resend switch-on signal.  Check position of RMI-Q; see operating envelope.
	Spin on is within 1 second of spin off.	Check for 1 second dwell following spin off.

Symptom	Cause	Action
<b>The machine stops unexpectedly during a probing cycle.</b>	Radio link failure/RLP40 out of range.	Check interface/receiver and remove obstruction.
	RMI-Q or RMI-QE receiver/machine fault.	Refer to receiver/machine user's guide.
	Dead batteries.	Change batteries.
	Excessive machine vibration causing false probe trigger.	Change trigger filter setting.
	Probe unable to find target surface.	Check that part is correctly positioned and that stylus has not broken.
	Stylus not given sufficient time to settle from a rapid deceleration.	Add a short dwell before the probing move (length of dwell will depend on stylus length and rate of deceleration).
	False probe trigger.	Change trigger filter setting.
	Selection error for RMI-Q or RMI-QE.	Review interface error indication and correct.
<b>The probe crashes.</b>	Workpiece obstructing probe path.	Review probing software.
	Probe length offset missing	Review probing software.
	In cases where there is more than one probe on a machine, incorrect probe activated.	Review interface wiring or part program.



Symptom	Cause	Action
<b>Poor probe repeatability and/or accuracy.</b>	Debris on part or stylus.	Clean part and stylus.
	Poor tool change repeatability.	Redatum probe after each tool change.
	Loose probe mounting on shank or loose stylus.	Check and tighten as appropriate.
	Excessive machine vibration.	Change trigger filter setting. Eliminate vibrations.
	Calibration out of date and/or incorrect offsets.	Review probing software.
	Calibration and probing speeds not the same.	Review probing software and make speeds the same.
	Calibration feature has moved.	Correct the position.
	Measurement occurs as stylus leaves surface.	Review probing software.
	Measurement occurs within the machine's acceleration and deceleration zone.	Review probing software and probe filter settings.
	Probing speed too high or too low.	Perform simple repeatability trials at various speeds.
	Temperature variation causes machine and workpiece movement.	Minimise temperature changes.
<b>RLP40 status LEDs do not correspond to RMI-Q or RMI-QE status LEDs.</b>	Radio link failure – RLP40 out of RMI-Q or RMI-QE range.	Check position of RMI-Q or RMI-QE, see operating envelope.
	RLP40 has been enclosed/shielded by metal.	Review installation.
	RLP40 and RMI-Q or RMI-QE are not partnered.	Partner RLP40 and RMI-Q or RMI-QE.

Symptom	Cause	Action
<b>RMI-Q or RMI-QE error LED lit during probing cycle.</b>	Probe not switched on or probe timed out.	Change setting. Review “ <b>switch-off</b> ” method.
	Probe out of range.	Check position of RMI-Q or RMI-QE; see operating envelope.
	Dead batteries.	Change batteries.
	RLP40 and RMI-Q or RMI-QE are not partnered.	Partner RLP40 with RMI-Q or RMI-QE.
	Probe selection error.	Verify that one radio probe is working and is correctly selected on the RMI-Q or RMI-QE.
	0.5 second turn-on error.	Ensure that all radio probes are “Q” or “QE” marked probes, or change the RMI-Q or RMI-QE turn-on time to 1 second.
<b>RMI-Q or RMI-QE low battery LED lit.</b>	Low batteries.	Change batteries soon.
<b>Reduced range.</b>	Local radio interference.	Identify and remove.
<b>The probe fails to switch off.</b>	Incorrect “ <b>switch-off mode</b> ” configured.	Check configuration and alter as required.
	No RMI-Q or RMI-QE “start/stop” signal (“ <b>radio on mode</b> ” only).	Check RMI-Q or RMI-QE for green start LED.
	Probe in timeout mode and placed in tool magazine and being triggered by movement.	Use shorter timeout setting or use different “ <b>switch-off</b> ” method.
	Incorrect spin speed (“ <b>spin on mode</b> ” only).	Check spin speed.
<b>The probe goes into Trigger Logic™ configuration mode and cannot be reset.</b>	Probe was triggered when batteries were inserted.	Do not touch the stylus or stylus mounting face during battery insertion.

# Parts list

Item	Part number	Description
RLP40 (QE)	A-6717-0001	RLP40 (QE) probe with batteries, tools and support card (factory-set to radio on / radio off, trigger filter off).
RLP40H (QE)	A-6717-1001	RLP40H (QE) probe with batteries, tools and support card guide (factory-set to radio on / radio off, trigger filter off).
Battery	P-BT03-0007	½AA battery – lithium-thionyl chloride (two required).
Stylus	A-5003-3709	PS3-1C ceramic stylus 50 mm long with Ø6 mm ball.
Weak link kit	A-2085-0068	Weak link (Part no. M-2085-0069 × 2) and 5 mm A/F spanner.
Tool kit	A-4071-0060	Kit comprising: Ø1.98 mm stylus tool, 2 mm A/F hexagon key, M4 × 6 mm cone point grub screw (× 2), and M4 × 6 mm flat point grub screw (× 4).
Service kit	A-5625-0005	RLP40 eyelid service kit.
Battery cassette	A-5625-1166	RLP40 metal battery cassette kit.
Cassette seal	A-4038-0301	Battery cassette housing seal.
RMI-Q	A-5687-0049	RMI-Q (side exit) with 8 m (26.2 ft) cable, tools and support card.
RMI-Q	A-5687-0050	RMI-Q (side exit) with 15 m (49.2 ft) cable, tools and support card.
RMI-QE	A-6551-0049	RMI-QE with 8 m (26.2 ft) cable, tools and support card.
RMI-QE	A-6551-0050	RMI-QE with 15 m (49.2 ft) cable, tools and support card.
RMI-Q mounting bracket	A-2033-0830	RMI-Q mounting bracket with fixing screws, washers and nuts.
RMI-QE mounting bracket	A-6551-0120	RMI-QE mounting bracket with fixing screws, washers and nuts.
Styli tool	M-5000-3707	Tool for tightening/releasing styli.
Shank	A-5625-1003	Parallel shank kit 25 mm diameter.
Shank	A-5625-1007	Parallel shank kit 1 in diameter.
<b>Publications.</b> These can be downloaded from our website at <a href="http://www.renishaw.com">www.renishaw.com</a> .		
RLP40 (QE) QSG	H-6717-8500	Quick-start guide: for rapid set-up of the RLP40 (QE) probe.
RMI-Q QSG	H-5687-8500	Quick-start guide: for rapid set-up of the RMI-Q.
RMI-Q IG	H-5687-8504	Installation guide: for set-up of the RMI-Q.
RMI-QE QSG	H-6551-8500	Quick-start guide: for rapid set-up of the RMI-QE.
RMI-QE IG	H-6551-8520	Installation guide: for set-up of the RMI-QE.

Item	Part number	Description
Styli	H-1000-3200	Technical specifications guide: <i>Styli and accessories</i> – or visit our Online store at <a href="http://www.renishaw.com/shop">www.renishaw.com/shop</a> .
Probe software	H-2000-2298	Data sheet: <i>Probe software for machine tools – programs and features</i> .
Taper shanks	H-2000-2011	Data sheet: <i>taper shanks for machine tool probes</i> .



**Renishaw plc**  
New Mills, Wotton-under-Edge  
Gloucestershire, GL12 8JR  
United Kingdom

**T** +44 (0)1453 524524  
**F** +44 (0)1453 524901  
**E** [uk@renishaw.com](mailto:uk@renishaw.com)  
[www.renishaw.com](http://www.renishaw.com)

**RENISHAW**   
**apply innovation™**

**For worldwide contact details, visit**  
**[www.renishaw.com/contact](http://www.renishaw.com/contact)**