

RESOLUTE™ Siemens DRIVE-CLiQ encoder system Functional Safety installation guide and safety manual

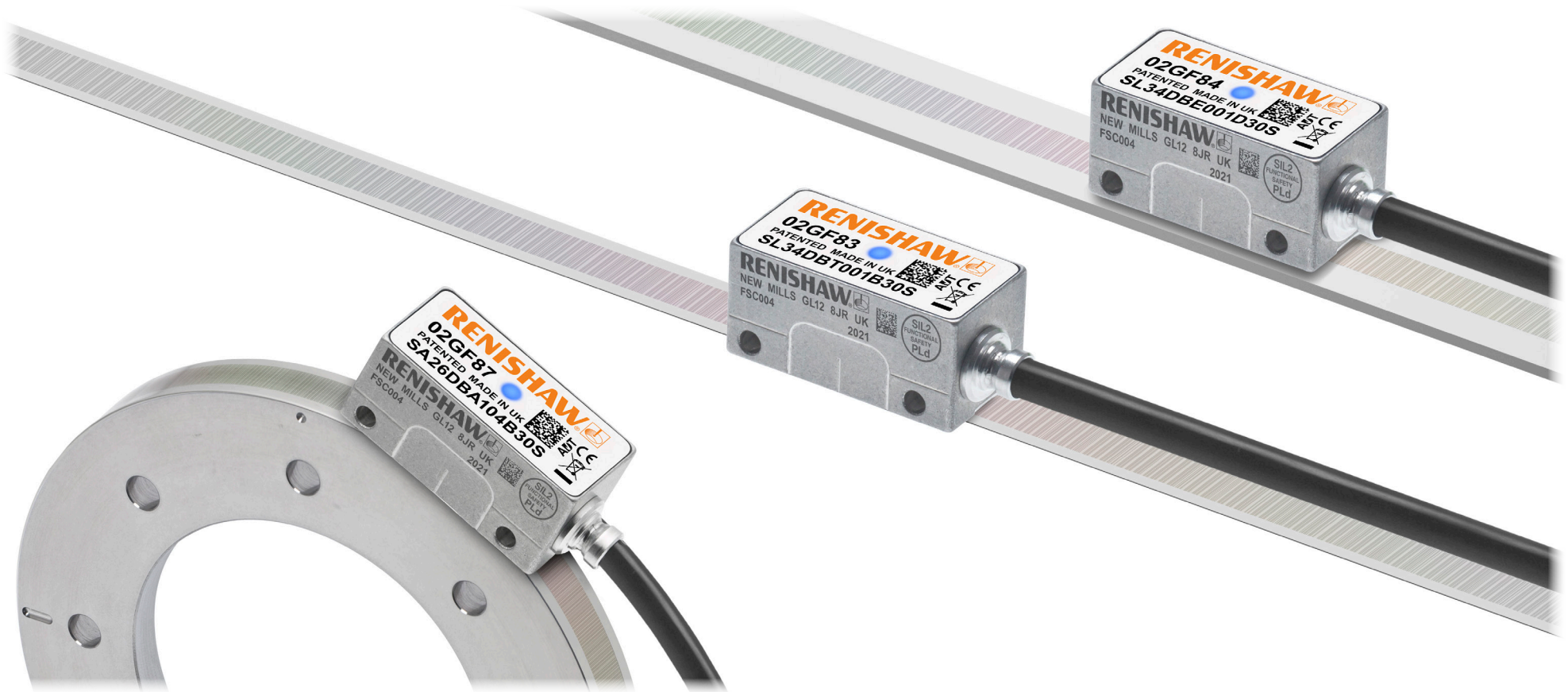

This page is intentionally left blank.

Contents

Legal notices	5
Definitions	8
Information for use	9
Functional Safety data declaration	10
Safety sub-functions	11
Safety function	12
Certification	16
Declaration of conformity	17
Storage and handling	19
Rotary RESOLUTE readhead installation drawing – standard cable outlet	22
Rotary RESOLUTE readhead installation drawing – side cable outlet	23
RESA30 ring specifications	24
RESA30 ‘A’ section ring installation drawing	26
RESA30 ‘B’ section ring installation drawing	28
RESA30 ring mounting options	30
Equipment required for taper mounting the RESA30 ‘A’ section ring	31
RESA30 ‘A’ section ring taper mounting	32
Equipment for interference fit mounting the RESA30 ‘A’ section and RESA30 ‘B’ section rings	36
RESA30 ‘A’ section and RESA30 ‘B’ section ring interference fit mounting	37
REXA30 ring specifications	38
REXA30 ring installation drawing	39
Equipment for flange mounting the REXA30 ring	41
REXA30 ring flange mounting	42
Siemens DRIVE-CLiQ dual head installation	46

Linear RESOLUTE readhead installation drawing – standard cable outlet47
Linear RESOLUTE readhead installation drawing – side cable outlet48
RELA30/RSLA30 spar scale technical specifications49
RELA30/RSLA30 scale installation drawing50
Equipment required for adhesive mounting the RELA30/RSLA30 spar scale51
Installing the adhesive mounted RELA30/RSLA30 scale52
RTLA30-S scale technical specifications54
RTLA30-S scale installation drawing55
Equipment required for installing the RTLA30-S scale56
Cutting the RTLA30-S scale57
Applying the RTLA30-S scale58
Fitting the end covers59
Fitting the datum clamp59
RTLA30/FASTRACK scale system technical specifications60
RTLA30/FASTRACK scale system installation drawing61
Equipment required for installing the RTLA30 and FASTRACK scale system62
Cutting the RTLA30 scale and FASTRACK carrier63
Applying the RTLA30 and FASTRACK scale system65
RESOLUTE readhead mounting and alignment68
System configuration70
Electrical connections71
RESOLUTE Functional Safety Siemens DRIVE-CLiQ Serial interface72
RESOLUTE output signals73
Siemens DRIVE-CLiQ interface drawing – single readhead input74
Siemens DRIVE-CLiQ interface drawing – dual readhead input75

Legal notices

Patents

Features of Renishaw's RESOLUTE encoder systems and similar products are the subjects of the following patents and patent applications:

CN102197282	EP2350570	JP5480284	KR1630471	US8505210
CN102388295	EP2417423	IN373822	JP5659220	KR1701535
US10132657	CN102460077	EP2438402	JP5755223	JP6074392
KR1851015	US10989567	US8466943	US7367128	CN102057256
EP2294363	EP2894438	JP5475759	JP5755299	KR1550483
US8141265				

Terms and conditions and warranty

Unless you and Renishaw have agreed and signed a separate written agreement, the equipment and/or software are sold subject to the Renishaw Standard Terms and Conditions supplied with such equipment and/or software, or available on request from your local Renishaw office.

Renishaw warrants its equipment and software for a limited period (as set out in the Standard Terms and Conditions), provided that they are installed and used exactly as defined in associated Renishaw documentation. You should consult these Standard Terms and Conditions to find out the full details of your warranty.

Equipment and/or software purchased by you from a third-party supplier is subject to separate terms and conditions supplied with such equipment and/or software. You should contact your third-party supplier for details.

Declaration of Conformity

Renishaw plc hereby declares that the RESOLUTE™ encoder system is in compliance with the essential requirements and other relevant provisions of:

- the applicable EU directives
- the relevant statutory instruments under UK law



The full text of the declaration of conformity is available at: www.renishaw.com/productcompliance.

Compliance

Federal Code Of Regulation (CFR) FCC Part 15 – RADIO FREQUENCY DEVICES

47 CFR Section 15.19

This device complies with part 15 of the FCC Rules. Operation is subject to the following two conditions: (1) This device may not cause harmful interference, and (2) this device must accept any interference received, including interference that may cause undesired operation.

47 CFR Section 15.21

The user is cautioned that any changes or modifications not expressly approved by Renishaw plc or authorised representative could void the user's authority to operate the equipment.

47 CFR Section 15.105

This equipment has been tested and found to comply with the limits for a Class A digital device, pursuant to part 15 of the FCC Rules. These limits are designed to provide reasonable protection against harmful interference when the equipment is operated in a commercial environment. This equipment generates, uses, and can radiate radio frequency energy and, if not installed and used in accordance with the instruction manual, may cause harmful interference to radio communications. Operation of this equipment in a residential area is likely to cause harmful interference in which case the user will be required to correct the interference at his own expense.

47 CFR Section 15.27

This unit was tested with shielded cables on the peripheral devices. Shielded cables must be used with the unit to ensure compliance.

Supplier's Declaration of Conformity

47 CFR § 2.1077 Compliance Information

Unique Identifier: RESOLUTE

Responsible Party - U.S. Contact Information

Renishaw Inc.
1001 Wesemann Drive
West Dundee
Illinois
IL 60118
United States
Telephone number: +1 847 286 9953
Email: usa@renishaw.com

ICES-001 — Industrial, Scientific and Medical (ISM) Equipment (Canada)

This ISM device complies with CAN ICES-001.

Cet appareil ISM est conforme à la norme ICES-001 du Canada.

Intended use

The RESOLUTE encoder system is designed to measure position and provide that information to a drive or controller in applications requiring motion control. It must be installed, operated, and maintained as specified in Renishaw documentation and in accordance with the Standard Terms and Conditions of the Warranty and all other relevant legal requirements.

Product compliance

This document is an installation guide and safety manual, which details the actions required for the safe integration of the RESOLUTE Functional Safety Siemens DRIVE-CLiQ encoder system, as designated by the SA for rotary or SL for linear prefix in the part number, into a functionally safe system, this system will be referred to as RESOLUTE Functional Safety in the below document.

The RESOLUTE Functional Safety system is suitable for use in a Category 3 Performance Level d (PLd) application in compliance with ISO13849 and in an SIL2 application in compliance with IEC 61508 when installed and operated in accordance with the instructions defined.

Failure to follow the correct use instructions and heed the limitations may result in SIL2 and / or PLd not being achieved and will invalidate the Functional Safety certification.

Further information

Further information relating to the RESOLUTE Functional Safety Siemens DRIVE-CLiQ encoder system can be found at www.renishaw.com/safety-encoders and is also available from your local Renishaw representative.

Packaging

The packaging of our products contains the following materials and can be recycled.

Packaging Component	Material	ISO 11469	Recycling Guidance
Outer box	Cardboard	Not applicable	Recyclable
	Polypropylene	PP	Recyclable
Inserts	Low density polyethylene foam	LDPE	Recyclable
	Cardboard	Not applicable	Recyclable
Bags	High density polyethylene bag	HDPE	Recyclable
	Metalised polyethylene	PE	Recyclable

REACH regulation

Information required by Article 33(1) of Regulation (EC) No. 1907/2006 ("REACH") relating to products containing substances of very high concern (SVHCs) is available at www.renishaw.com/REACH.

Disposal of waste electrical and electronic equipment



The use of this symbol on Renishaw products and/or accompanying documentation indicates that the product should not be mixed with general household waste upon disposal. It is the responsibility of the end user to dispose of this product at a designated collection point for waste electrical and electronic equipment (WEEE) to enable reuse or recycling. Correct disposal of this product will help to save valuable resources and prevent potential negative effects on the environment. For more information, please contact your local waste disposal service or Renishaw distributor.

Definitions

WARNING A hazard with a medium risk of injury if not avoided

ESD handling		The ESD Susceptibility Symbol consists of a triangle, a reaching hand, and a slash through the reaching hand. The triangle means 'Caution' and the slash through the reaching hand means 'Don't touch'.
Mechanical safe position		The maximum distance the scale might move from its installed position, for example if the fixings work loose.
Evaluation unit		External item of equipment in which the output signal of the encoder is evaluated, e.g. machine controller or safety relay.
System manufacturer		Personnel with responsibility for selecting the encoder and verifying its capability is appropriate for the safety related application.
System installer		Personnel with responsibility for fitting the encoder in the specific application.

Information for use

WARNING Not to be used in environments where there is an explosive atmosphere

WARNING Not to be used by medical devices

The RESOLUTE Functional Safety Siemens DRIVE-CLiQ encoder system is designed to be used as part of a safety-related control system as specified by the system manufacturer. It is the responsibility of the system manufacturer to set the evaluation unit to implement the appropriate actions when the RESOLUTE Functional Safety Siemens DRIVE-CLiQ encoder system reports an error.

The decision to use this system for the intended purpose is the responsibility of the system manufacturer. The RESOLUTE Functional Safety Siemens DRIVE-CLiQ encoder system is certified to the SIL and PL levels as shown in the 'Functional Safety data declaration' table; however, the system manufacturer must conduct their own assessment of the full system to determine its safety capability.

Correct use includes:

- Operating the RESOLUTE Functional Safety Siemens DRIVE-CLiQ encoder system within the limits defined in this document.
- Installing the system as described in this document.
- Maintaining the system as described in this document.

System components covered by this installation guide:

The RESOLUTE Functional Safety Siemens DRIVE-CLiQ encoder system comprises of the following parts:

- RESOLUTE Functional Safety readhead(s) with integral cable
- DRIVE-CLiQ interface (single and dual readhead)
- Taper mounted RESA30 'A' section rings
- Interference mounted RESA30 'A' section/'B' section rings
- REXA30 rings
- RTLA30-S tape scale
- RTLA30 tape scale and *FASTRACK* carrier
- RSLA30 and RELA30 linear scale – adhesive mount only
- Accessories

NOTES:

- Rings retained by interference fit only (unbolted) are not approved for use with the RESOLUTE Functional Safety Siemens DRIVE-CLiQ encoder system.
- Clip mounting RELA30/RSLA30 linear scale is not approved for use with the RESOLUTE Functional Safety Siemens DRIVE-CLiQ encoder system.

If the original termination is altered by the user or an extension cable is used, then it is the responsibility of the system manufacturer to make sure the system is compliant with IEC 61800-5-2 Annex E second environment – Electromagnetic immunity requirement for safety related systems.

Functional Safety data declaration

Product identification	RESOLUTE™ Functional Safety Siemens DRIVE-CLiQ encoder system
------------------------	---

IEC 61508 safety data

	Single readhead system	Dual readhead system
Safety Integrity Level	2	
Random Hardware Failures (per hour)	$\lambda_s = 6.86 \times 10^{-7}$ $\lambda_D = 1.07 \times 10^{-6}$ $\lambda_{DD} = 9.64 \times 10^{-7}$ $\lambda_{DU} = 1.07 \times 10^{-7}$	$\lambda_s = 1.26 \times 10^{-6}$ $\lambda_D = 1.95 \times 10^{-6}$ $\lambda_{DD} = 1.76 \times 10^{-6}$ $\lambda_{DU} = 1.96 \times 10^{-7}$
PFD _{avg}	Not applicable due to continuous use	
PFH (per hour)	$\lambda_{DU} = 1.07 \times 10^{-7}$	$\lambda_{DU} = 1.95 \times 10^{-7}$
Architectural Constraints	Type B HFT = 0 SFF = 94%	
Hardware safety integrity compliance	Route 1H	
Systematic safety integrity compliance	Route 1S	
Systematic capability	SC2	
Demand mode	Continuous	
Proof test interval	Not required for continuous demand mode	

ISO 13849 safety data

	Single readhead system	Dual readhead system
MTTF _D (years)	106	58
Diagnostic coverage	Medium (90%)	
Category	3	
Performance level	d	
Lifetime/Replacement limits	20 years	

Safety sub-functions

The RESOLUTE Functional Safety Siemens DRIVE-CLiQ encoder system provides safe position data that supports the following safety sub-functions defined by IEC 61800-5-2:

- Safe stop 1 (SS1) and Safe stop 2 (SS2)
- Safe operating stop (SOS)
- Safe limited acceleration (SLA) $\leq 500 \text{ m/s}^2$
- Safe acceleration range (SAR) $\leq 500 \text{ m/s}^2$
- Safe limited speed (SLS) ¹ $\leq 100 \text{ m/s}$
- Safe speed range (SSR) ¹ $\leq 100 \text{ m/s}$
- Safely limited position (SLP)
- Safely limited increment (SLI)
- Safe direction (SDI)
- Safe speed monitor (SSM) ¹ $\leq 100 \text{ m/s}$

¹ See the installation specifications for RESA and REXA for the maximum permitted speeds for the range of ring diameters.

Safety function

The RESOLUTE Functional Safety Siemens DRIVE-CLiQ encoder system shall provide a safe position when requested by the controller.

The following restrictions apply to this claim:

- The maximum request rate supported is 16 kHz.
- The RESOLUTE Functional Safety Siemens DRIVE-CLiQ encoder system can support:

Resolution	1 nm	50 nm
Maximum scale length (L) with 34 bit position word	17.18 m	N/A
Maximum scale length (L) with 28 bit position word	N/A	13.42 m

- The RESOLUTE Functional Safety Siemens DRIVE-CLiQ encoder system shall allow electrical errors to be detected by the controller at least for:
 - **Linear systems:** electrical error exceeding 600 μm
 - **Rotary systems:** electrical error exceeding 1.5°
- Provided it is installed correctly, the RESOLUTE Functional Safety Siemens DRIVE-CLiQ encoder system shall have:
 - **Linear systems:** mechanical error not exceeding ± 1 mm
 - **Rotary systems:** mechanical error not exceeding $\pm 2.5^\circ$, refer to page 24 and page 25 (RESA) or page 38 (REXA)
- Any thermal expansion effects of the scale are excluded from the accuracy of the safe position.
- The controller checks whether the obtained position data lie in the position window expected by the controller. Unexpected position data include position jumps and incorrect direction of travel.
- When errors are detected by the controller it is the responsibility of the system manufacturer to introduce appropriate safety measures e.g. safe stop etc.
- The machine controller that interfaces to the RESOLUTE Functional Safety encoder must have its Functional Safety functions enabled (as often it is a configuration parameter to turn on Functional Safety functionality), as this is necessary for the RESOLUTE Functional Safety to be valid.

- The system manufacturer must ensure that the scale and the readhead are mounted securely and cannot become detached from their mounting points e.g. a bracket fails.
- It is the responsibility of the machine builder to validate the safety functions of the RESOLUTE Functional Safety Siemens DRIVE-CLiQ encoder system in the specific application.
- The system manufacturer must perform a verified commissioning test during installation.
- The system repairer must perform a verified commissioning test following replacement of a system part.

Fault exclusions

The following actions will invalidate the Functional Safety certification of the RESOLUTE Functional Safety system:

- Faults caused by cutting and reconnecting the readhead cable or extending the readhead cable.
- Incorrect installation of the readhead.
- Incorrect installation of the rotary or linear scale.
- Failure to follow the instructions contained within this installation manual.
- Dismantling of the RESOLUTE readhead or the Siemens DRIVE-CLiQ interface.
- Operating the system outside of the limits specified within this installation manual.

Failure modes effects and diagnostics analysis

All diagnosed failure modes are detected immediately except for a position discrepancy between the two measurement methods which is detected within 375 µs.

See 'Functional Safety data declaration' on page 10 for a summary of the FMEDA.

NOTE: For the purposes of the FMEDA calculation the following conditions have been assumed:

Method	SN29500-2005-1
Environment	Ground mobile
Temperature	85 °C for the readhead and 60 °C for the interface

Installation

For the safety function to be valid the instructions detailed in this installation guide must be followed. The information relating to all scale types and mounting options is listed. The builder/installer/maintainer/repairer must apply the instructions for the product being installed as defined by this installation guide.

The following general conditions must be observed during installation:

- Observe ESD handling precautions when handling the cable connectors.
- Cleaning mating surfaces before mounting the rotary or linear scales.

Commissioning test

The following checks **MUST** be performed following installation and commissioning of the RESOLUTE Functional Safety Siemens DRIVE-CLiQ encoder system for the first time, and also following repair of the system (replacement systems parts):

Error bit check	Power the RESOLUTE Functional Safety Siemens DRIVE-CLiQ encoder system and confirm that the error bit as received by the Siemens controller is clear. Place business card or similar between the readhead and the scale to block the light path. Confirm that the error bit as received by the Siemens controller is active and stays active once the card is removed.
Scale code check	Clear the error bit (by cycling power to the system). Move axis over its full travel and check that no errors are latched with the Siemens controller. This check needs to be performed at a traverse speed (circumferential speed for rotary) of < 2 m/s to ensure that the readhead checks every code written on the scale.
Position count direction	Clear the error bit and check that the position count direction is as expected.
Resolution check	Move the axis by a known distance and confirm that the position count changes as expected to a tolerance determined by the manufacturer's risk assessment.

NOTE: Should the working temperature of the readhead need to be measured attach a suitable sensor directly to the aluminium readhead housing. Do not attach to the label that shows the product details. Do not drill into the housing as this may compromise the sealing or technical function. Route the sensor cable away from moving parts and along the same path as the readhead cable.

Evaluation unit monitoring

To achieve full system integrity the evaluation unit must continuously monitor the error condition of the RESOLUTE Functional Safety Siemens DRIVE-CLiQ encoder system and in the case of fault detection, place the system into a safe state within the process safety time.

NOTES:

- The evaluation unit must have its Functional Safety functions enabled (as often it is a configuration parameter to turn on Functional Safety functionality) and must respond correctly to a RESOLUTE Functional Safety Siemens DRIVE-CLiQ encoder system position error flag.
 - A persistent fault condition may indicate a hardware failure of the RESOLUTE Functional Safety Siemens DRIVE-CLiQ encoder system or an installation problem.
-

Storage and handling

DO ensure that protection is provided for the scale, readhead and interfaces when transporting a machine with that equipment already installed.

DO store scale in a cool dry place out of direct sunlight and in its original packaging prior to installation. When stored on a reel ensure that the backing tape is facing out.

DO allow scale to acclimatize to installation environment prior to installation.

DO store at < 95% RH

DO operate at < 80% RH

DO install between 15 °C and 25 °C

DO store between –20 °C and +80 °C

DO operate between 0 °C and +80 °C (readhead and scale), 0 °C and +55 °C (interface)

Maintenance and cleaning

In order to retain full Functional Safety compliance, this encoder system needs to be maintained appropriately. The maintenance check intervals will be defined by the machine builder/installer according to their risk assessment. There are no user serviceable parts within the readhead or interface. The lid of the readhead must not be removed as it will break the seal.

The following checks should be carried out:

- Check the readhead to bracket screws are correctly tightened.
- Check for worn or damaged cable connecting the readhead to the interface.
- Check that the scale has not been damaged or contaminated. If required, clean the system using approved solvents (see 'Storage and handling' on page 19).

NOTES:

- Do not re-tighten the screws securing the encoder ring as this will change the ring settings.
 - Do not attempt to move the linear scale as this will damage the adhesive bond.
-

When cleaning the system:

DO use Renishaw (A-9523-4040) alcohol wetted scale wipes to clean the readhead optics and scale, available from your local Renishaw representative.

Or use a clean, dry, lint-free cloth.

Or use only the following solvents sparingly with a wetted lint-free cloth:

- Propan-2-ol (iso-propyl alcohol) $\text{CH}_3\text{CHOHCH}_3$
- n-Heptane $\text{CH}_3(\text{CH}_2)_5\text{CH}_3$

DO NOT use the following aggressive solvents to clean the RESOLUTE Functional Safety Siemens DRIVE-CLiQ readhead, DRIVE-CLiQ interface, RTLA30-S and RTLA30 scales, or the *FASTRACK* carrier:

- Acetone CH_3COCH_3
- Chlorinated solvents
- Methylated spirits

Repair

Repair is by replacement of systems parts only. New parts must have the same part number as the parts being replaced. Any variances must be agreed with Renishaw. The new system must be installed and commissioned in accordance with the 'Commissioning test' on page 13. It is advisable that, in the event of failure, the affected parts should be returned to Renishaw for further analysis prior to any replacement parts being sent. Using damaged parts invalidates Functional Safety certification.

Proof testing

It is the responsibility of the system manufacturer to define any proof testing of the system. Due to the diagnostic coverage (DC) and safe failure fraction (SFF) required to achieve SIL2, the encoder can only support continuous demand use.

Certification

RESOLUTE Functional Safety Siemens DRIVE-CLiQ encoder system Functional Safety Certificate No. FSC004



Under the terms of CSA SIRA Functional Safety Certificate SIRA CASS00023/02, for the management and self-certification of functional safety activities up to SIL3/PLd:

Renishaw plc declares that the products shown by this installation guide meet the requirements of:

IEC 61508-1:2010, IEC 61508-2:2010 and IEC 61508-3:2010

IEC 61800-5-2:2016

ISO 13849-1:2015 and ISO 13849-2:2012

IEC 61784-3:2016

when used as an element/subsystem in safety related systems performing safety functions requiring up to and including:

SIL2 with HFT = 0 (1oo1)

Category 3, PLd

The Siemens certification for the above system is:

Rotary applications C00041

Linear applications C00042

Declaration of conformity

Summary of the EU declaration of conformity EUD2021-00868

This declaration of conformity is issued under the sole responsibility of the manufacturer, Renishaw plc.

The object of the declaration is identified below: -

Product name:	RESOLUTE™ Functional Safety Siemens DRIVE-CLiQ encoder system
Description:	Revision of RESOLUTE, to comply with the requirements of Functional Safety.

Part number:	Valid from:	Description:
SL34D*	0CC467	RESOLUTE FS Siemens 34BIT
SL28D*	OLIU05	RESOLUTE FS Siemens 28BIT
SA26D*	OH0E91	RESOLUTE FS Siemens 26BIT
SA29D*	0A7X63	RESOLUTE FS Siemens 29BIT
A-9796-0590	-01	RESOLUTE FS DRIVE-CLiQ interface – dual
A-9796-0575	-01	RESOLUTE FS DRIVE-CLiQ interface – single

The object of the declaration described above is in conformity with all relevant EU harmonisation legislation and fulfils all the relevant provisions with EU directives: -

2006/42/EC	Machinery Directive
2014/30/EU	Electromagnetic Compatibility (EMC)
2011/65/EU	On the restriction of the use of certain hazardous substances in electrical and electronic equipment - RoHS

and complies with the following technical standards: -

EN ISO 12100:2010	Safety of machinery - General principles for design - Risk assessment and risk reduction (ISO 12100:2010)
EN ISO 13849-1:2015	Safety of machinery - Safety-related parts of control systems - Part 1: General principles for design (ISO 13849-1:2015)
EN ISO 13849-2:2012	Safety of machinery - Safety-related parts of control systems - Part 2: Validation (ISO 13849-2:2012)
EN 61326-1:2013	Electrical equipment for measurement, control and laboratory use - EMC requirements - Part 1: General requirements
EN 62471:2008	Photobiological safety of lamps and lamp systems
EN IEC 63000:2018	Technical documentation for the assessment of electrical and electronic products with respect to the restriction of hazardous substances

For the full declaration of conformity EUD2021-00817 see www.renishaw.com/productcompliance.

EU based person authorised to compile the technical file: - Renishaw (Ireland) DAC, Swords Business Park, Swords, Co. Dublin, K67 FX67, Ireland.

Summary of the UK declaration of conformity UKD2021-00868

This declaration of conformity is issued under the sole responsibility of the manufacturer, Renishaw plc.

The object of the declaration is identified below: -

Product name:	RESOLUTE™ Functional Safety Siemens DRIVE-CLiQ encoder system
Description:	Revision of RESOLUTE, to comply with the requirements of Functional Safety.

Part number:	Valid from:	Description:
SL34D*	0CC467	RESOLUTE FS Siemens 34BIT
SL28D*	OLIU05	RESOLUTE FS Siemens 28BIT
SA26D*	OH0E91	RESOLUTE FS Siemens 26BIT
SA29D*	0A7X63	RESOLUTE FS Siemens 29BIT
A-9796-0590	-01	RESOLUTE FS DRIVE-CLiQ interface – dual
A-9796-0575	-01	RESOLUTE FS DRIVE-CLiQ interface – single

The object of the declaration described above is in conformity with all relevant UK Statutory Instruments (and their amendments): -

S.I. 2008 No. 1597	Supply of Machinery (Safety) Regulations 2008
S.I. 2016 No. 1091	Electromagnetic Compatibility Regulations 2016
S.I. 2012 No. 3032	The Restriction of the Use of Certain Hazardous Substances in Electrical and Electronic Equipment Regulations 2012 - RoHS

and complies with the following technical standards: -

EN ISO 12100:2010	Safety of machinery - General principles for design - Risk assessment and risk reduction (ISO 12100:2010)
EN ISO 13849-1:2015	Safety of machinery - Safety-related parts of control systems - Part 1: General principles for design (ISO 13849-1:2015)
EN ISO 13849-2:2012	Safety of machinery - Safety-related parts of control systems - Part 2: Validation (ISO 13849-2:2012)
EN 61326-1:2013	Electrical equipment for measurement, control and laboratory use - EMC requirements - Part 1: General requirements
EN 62471:2008	Photobiological safety of lamps and lamp systems
EN IEC 63000:2018	Technical documentation for the assessment of electrical and electronic products with respect to the restriction of hazardous substances

For the full declaration of conformity UKD2021-00817 see www.renishaw.com/productcompliance.

Storage and handling

RESOLUTE non-contact optical encoder systems provide good immunity against contaminants such as dust, fingerprints and light oils. However, in harsh environments such as machine tool applications, protection should be provided to prevent ingress of coolant or oil.

Ring

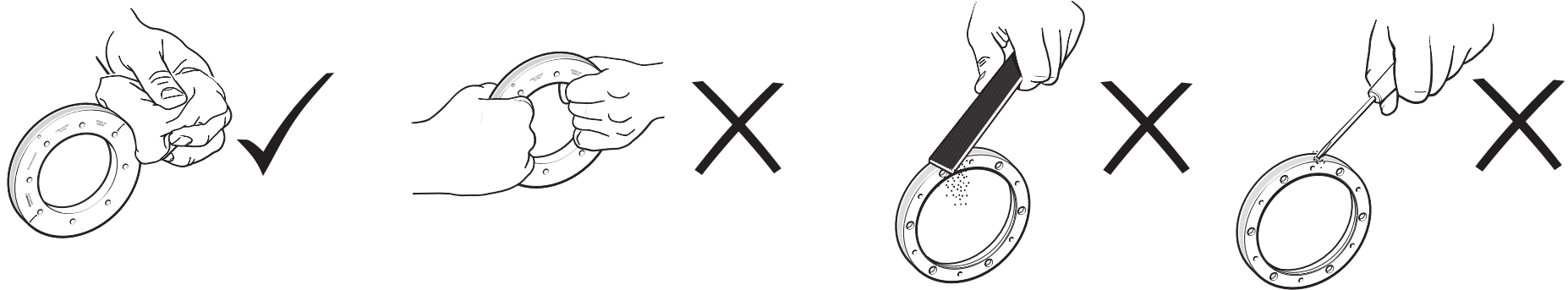

Linear scale

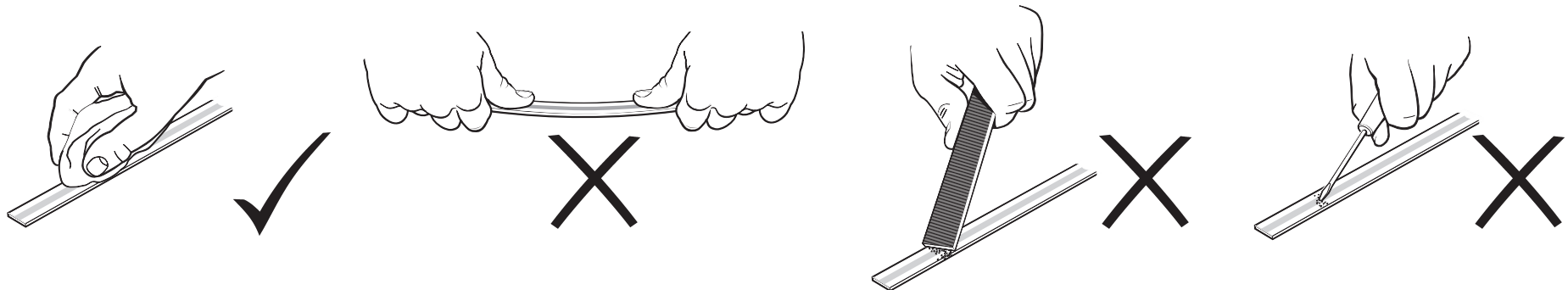

Minimum bend radius

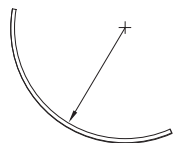

RSLA30 - 250 mm	RTLA30-S - 150 mm	RTLA30 - 50 mm
FASTRACK - 200 mm	RELA30 - DO NOT BEND	

NOTE: Ensure self-adhesive tape is on the outside of the bend.

System

RELA30/RSLA30 scale and rings only

RTLA30-S and RTLA30 scales, *FASTRACK* carrier, RESOLUTE readhead and DRIVE-CLiQ interface

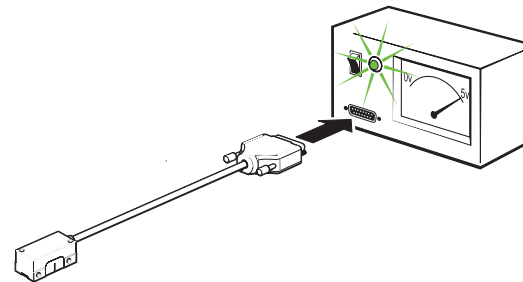
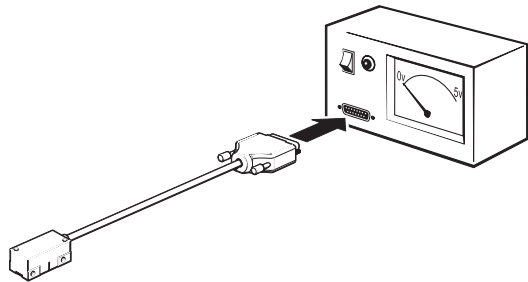
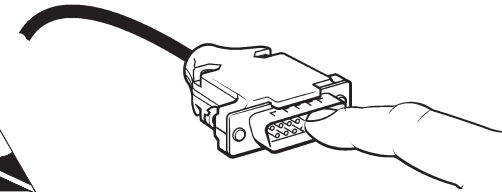
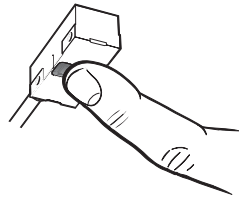
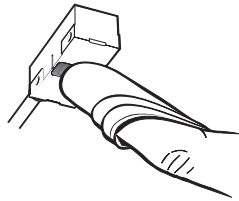
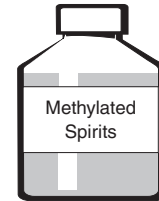
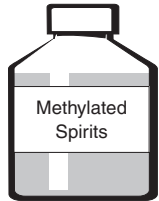
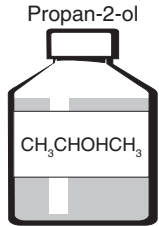
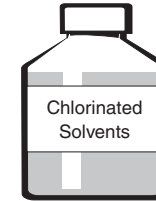
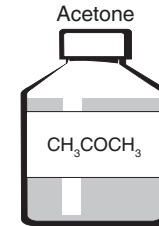
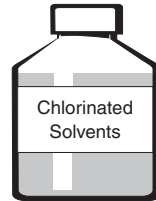
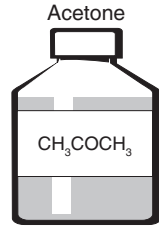
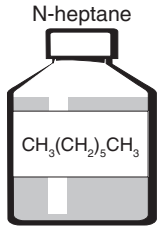

Temperature

Storage	
System	-20 °C to +70 °C

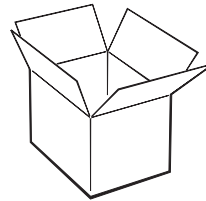

Operating	
Readhead and scales	0 °C to +80 °C
DRIVE-CLiQ interface	0 °C to +55 °C

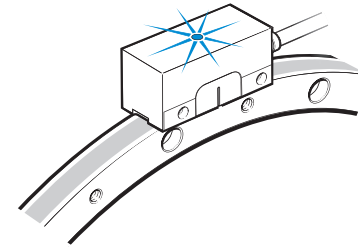
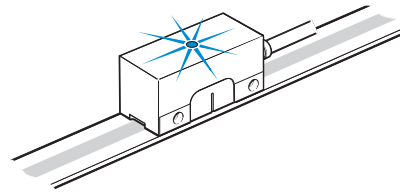

Humidity

95% relative humidity (non-condensing) to IEC 60068-2-78

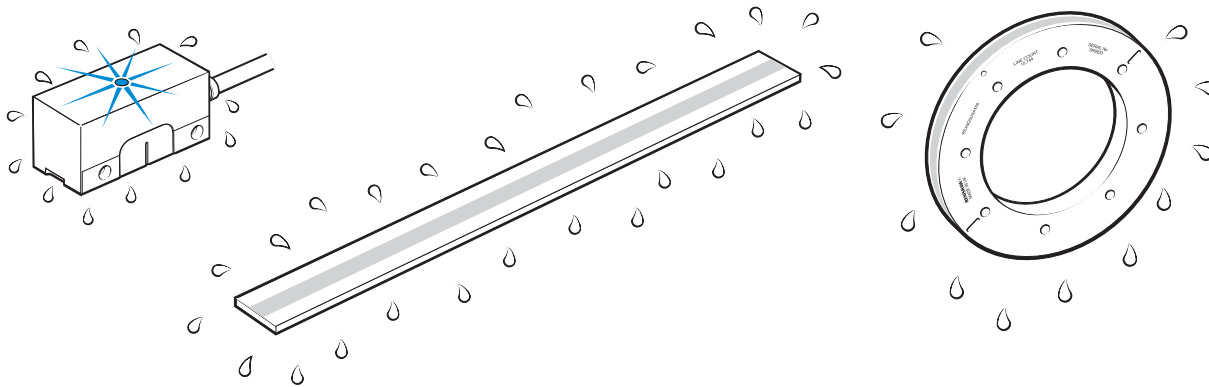

Rotary RESOLUTE readhead installation drawing – standard cable outlet

Dimensions and tolerances in mm

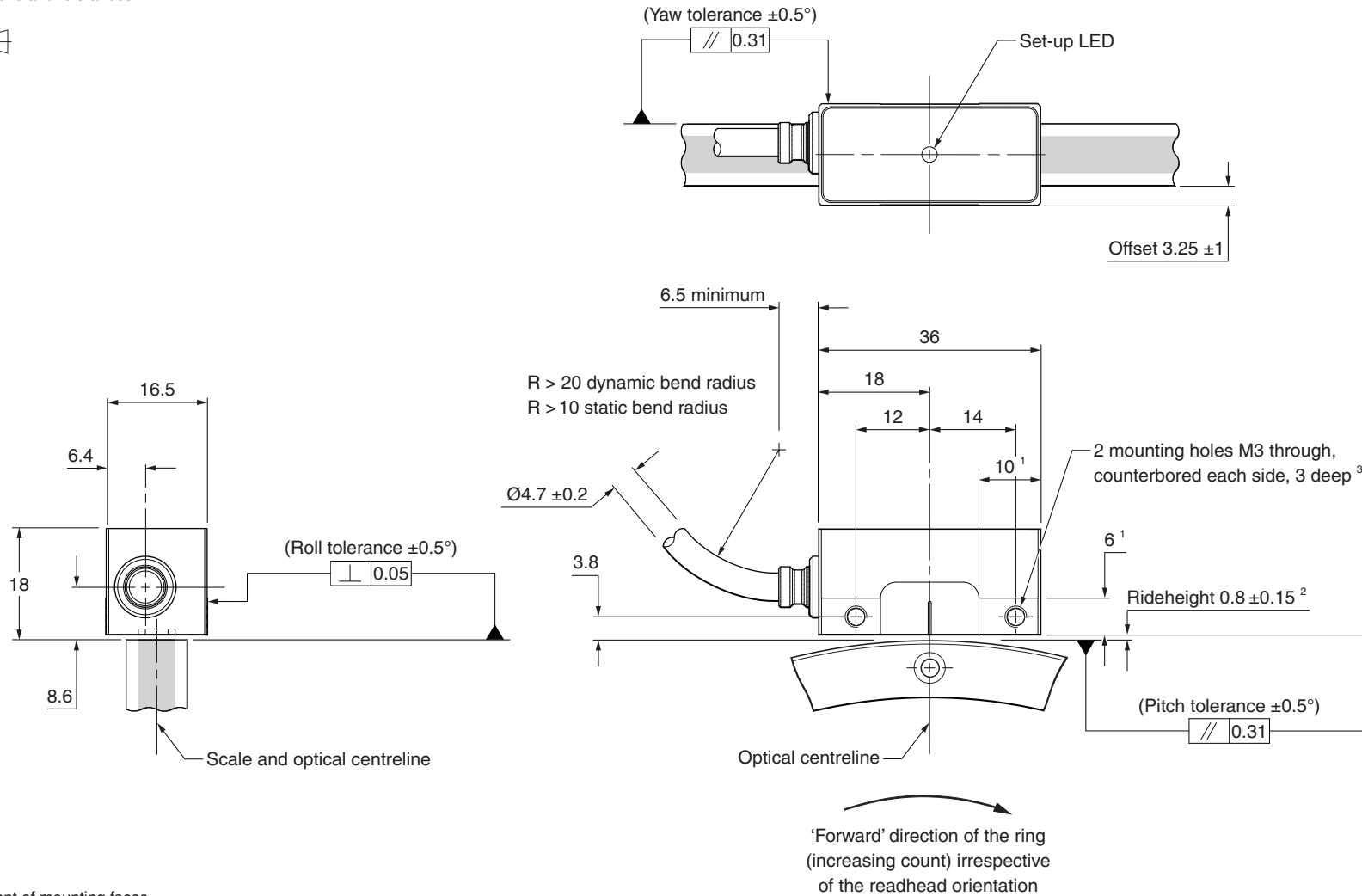

¹ Extent of mounting faces.

² 0.8 ± 0.1 mm on 52 mm rings.

³ The recommended thread engagement is 6 mm minimum (9 mm including counterbore) and the recommended tightening torque is 0.9 Nm to 1.1 Nm.

NOTE: RESOLUTE readhead shown on RESA ring

Rotary RESOLUTE readhead installation drawing – side cable outlet

Dimensions and tolerances in mm

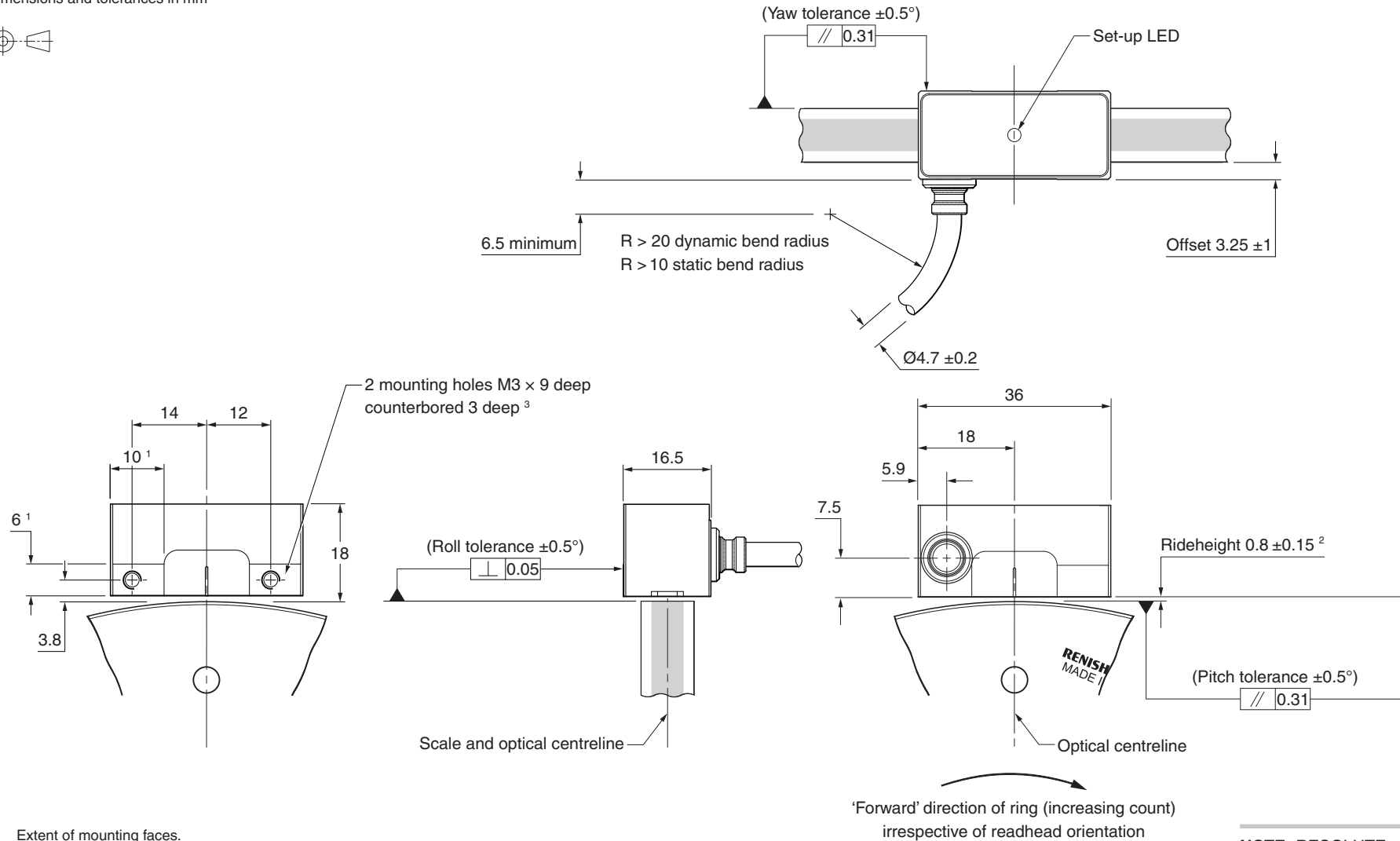

- ¹ Extent of mounting faces.
- ² 0.8 ± 0.1 mm on 52 mm rings.
- ³ The recommended thread engagement is 6 mm minimum (9 mm including counterbore) and the recommended tightening torque is 0.9 Nm to 1.1 Nm.

NOTE: RESOLUTE readhead shown on REXA ring

RESA30 ring specifications

The RESA ring must be installed and operated with the following specifications.

Installation temperature	20 ±5 °C
Operating temperature range	0 °C to 80 °C
Mounting shaft coefficient of thermal expansion at 20 °C	15.5 ±0.5 µm/m/°C

RESA30 ring taper mount

Safety factor	2
Safe position	±0.2 mm

Ring diameter (mm)	Maximum permissible speed (rpm)	Mechanical safe position (°)
52	18 300	0.441
57	16 700	0.402
75	12 700	0.306
100	9 540	0.229
101	9 450	0.229
103	9 270	0.223
104	9 180	0.220
115	8 300	0.199
124	7 700	0.185
150	5 260	0.153
172	4 520	0.133
183	4 180	0.125
200	4 280	0.115

Ring diameter (mm)	Maximum permissible speed (rpm)	Mechanical safe position (°)
206	4 150	0.111
209	3 900	0.110
229	3 700	0.100
255	3 340	0.090
280	2 980	0.082
300	2 490	0.076
330	2 260	0.069
350	2 110	0.065
413	1 870	0.055
417	2 170	0.055
489	1 890	0.047
550	1 640	0.042

NOTE: The 'Mechanical Safe Position' is the maximum distance the scale might move from its installed position and will be undetected by the readhead.

RESA30 'A' section ring interference fit

Safety factor	2
Safe position	±1 mm

Ring diameter (mm)	Maximum permissible speed (rpm)	Mechanical safe position (°)
52	5 900	2.204
57	5 200	0.402
75	3 800	1.528
100	2 700	1.146
101	2 600	1.135
103	2 500	1.113
104	2 400	1.102
115	2 400	0.996
124	2 200	0.924
150	2 100	0.764
172	1 800	0.666
183	1 700	0.626
200	1 800	0.573
206	1 700	0.556
209	1 600	0.548
229	1 500	0.500
255	1 400	0.449
280	1 200	0.409
300	1 300	0.382
330	1 200	0.347
350	1 100	0.327
413	1 000	0.277

RESA30 'B' section ring interference fit

Safety factor	2
Safe position	±1 mm

Ring diameter (mm)	Maximum permissible speed (rpm)	Mechanical safe position (°)
52	8 800	2.204
57	7 800	2.010
75	5 600	1.528
100	4 100	1.146
115	3 600	0.996
150	3 200	0.764
165	2 900	0.694
200	2 700	0.573

NOTE: The 'Mechanical Safe Position' is the maximum distance the scale might move from its installed position and will be undetected by the readhead.

RESA30 'A' section ring installation drawing

Dimensions and tolerances in mm

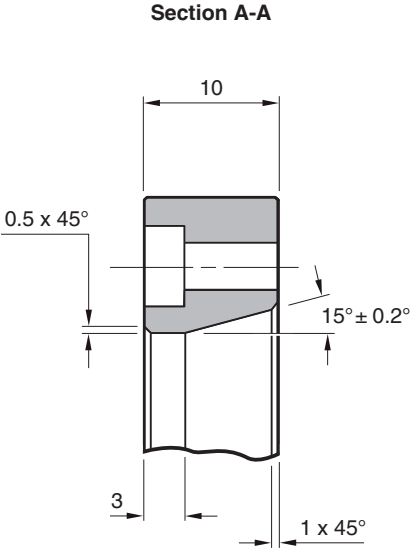
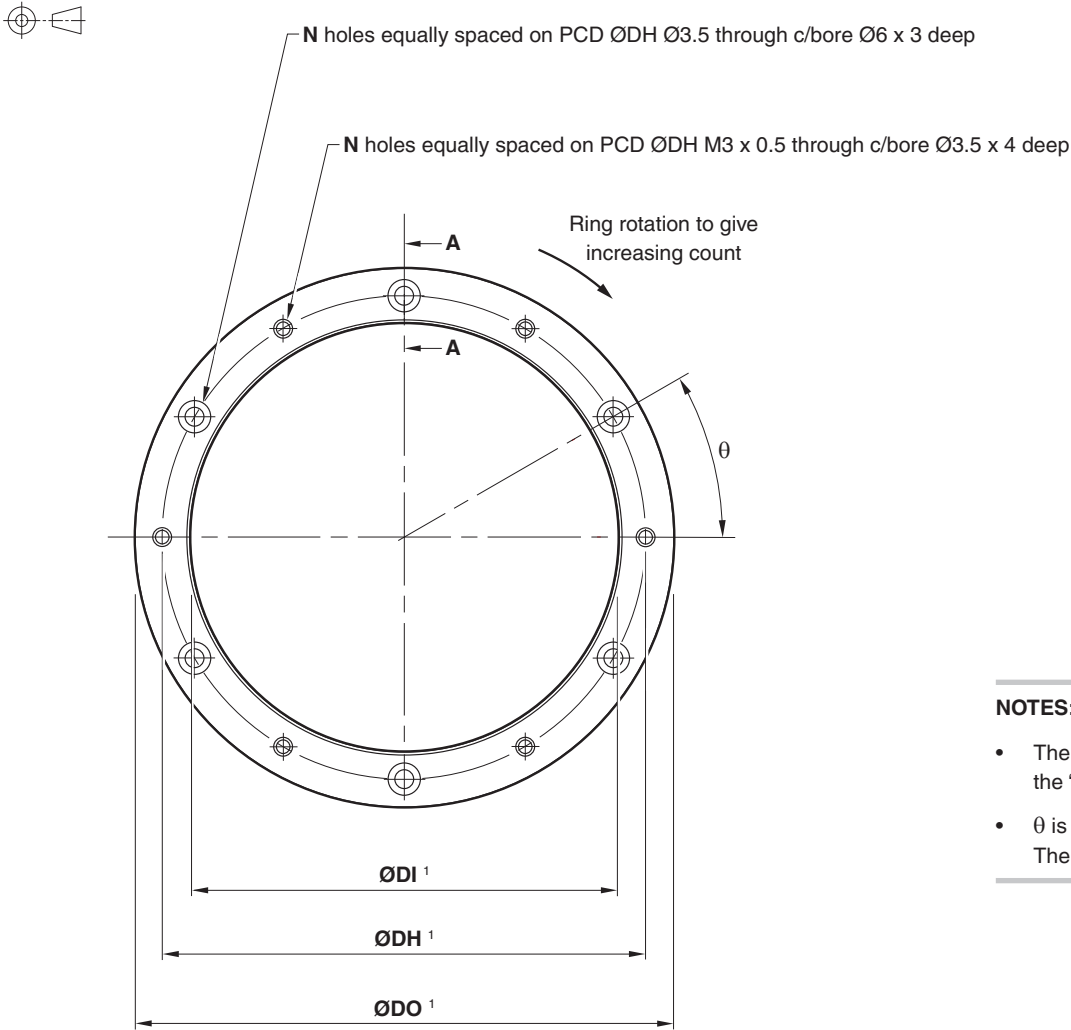

NOTES:

- The scale zero position is radially aligned with the centre of the mounting hole to the left of the 'Renishaw' logo.
- θ is the angle between one tapped hole and the adjacent clearance hole. The angle between two clearance holes is 2θ .

¹ The dimensions DO, DI and DH for the RESA30 'A' section rings are listed on the following page.

RESA30 'A' section ring dimensions

Nominal external diameter (mm)	DO (mm)	DI (mm)	Mounting holes		
			DH (mm)	N	θ
52	52.20 52.10	30.04 30.00	40	6	30°
57	57.35 57.25	37.04 37.00	47	6	30°
75	75.40 75.30	55.04 55.00	65	6	30°
100	100.30 100.20	80.04 80.00	90	6	30°
101	101.30 102.20	80.04 80.00	90	6	30°
103	103.20 103.00	80.04 80.00	90	6	30°
104	104.40 104.20	80.04 80.00	90	6	30°
115	114.70 114.50	95.04 95.00	105	6	30°
124	124.10 123.90	104.04 104.00	114	6	30°
150	150.40 150.20	130.04 130.00	140	9	20°
172	172.04 171.84	152.04 152.00	162	9	20°
183	183.45 183.25	163.04 163.00	172	9	20°
200	200.40 200.20	180.04 180.00	190	12	15°
206	206.50 206.10	186.05 186.00	196	12	15°
209	208.80 208.40	186.05 186.00	196	12	15°
229	229.40 229.00	209.05 209.00	219	12	15°

Nominal external diameter (mm)	DO (mm)	DI (mm)	Mounting holes		
			DH (mm)	N	θ
255	254.80 254.40	235.06 235.00	245	12	15°
280	280.30 279.90	260.06 260.00	270	12	15°
300	300.40 300.20	280.06 280.00	290	16	11.25°
330	330.10 329.90	310.06 310.00	320	16	11.25°
350	350.40 350.20	330.06 330.00	340	16	11.25°
413	412.70 412.30	392.08 392.00	402	18	10°
417	417.40 417.00	380.10 380.00	390	18	10°
489 ¹	489.12 488.72	451.10 450.90	462	20	18°
550	550.20 549.80	510.10 510.00	520	20	9°

IMPORTANT: RESOLUTE readheads must be used with the correct size RESA30 ring. Ensure matching part numbers when ordering.

¹ There are no tapped holes on the 489 mm ring

RESA30 'B' section ring installation drawing

Dimensions and tolerances in mm

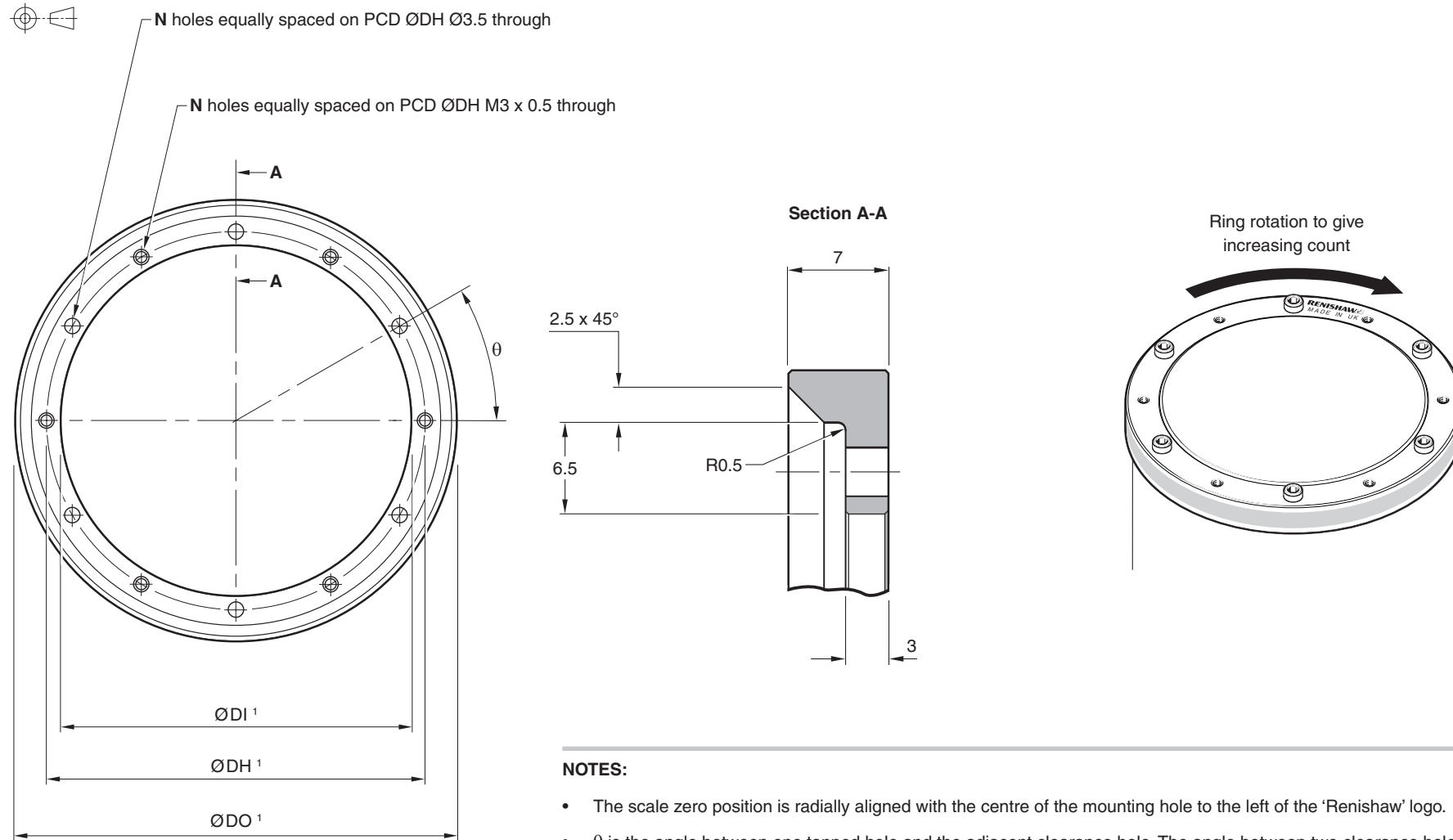

NOTES:

- The scale zero position is radially aligned with the centre of the mounting hole to the left of the 'Renishaw' logo.
- θ is the angle between one tapped hole and the adjacent clearance hole. The angle between two clearance holes is 20.

¹ The dimensions DO, DI and DH for the RESA30 'B' section rings are listed on the following page.

RESA30 'B' section ring dimensions

Nominal external diameter (mm)	DO (mm)	DI (mm)	Mounting holes		
			DH (mm)	N	θ
52	52.20	32.04	38	6	30°
	52.10	32.00			
57	57.35	37.04	43	6	30°
	57.25	37.00			
75	75.40	55.04	61	6	30°
	75.30	55.00			
100	100.30	80.04	86	6	30°
	100.20	80.00			
115	114.70	95.04	101	6	30°
	114.50	95.00			
150	150.40	130.04	136	9	20°
	150.20	130.00			
165	165.10	145.04	151	9	20°
	164.90	145.00			
200	200.40	180.04	186	12	15°
	200.20	180.00			

IMPORTANT: RESOLUTE readheads must be used with the correct size RESA30 ring. Ensure matching part numbers when ordering.

RESA30 ring mounting options

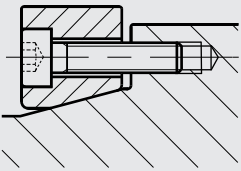
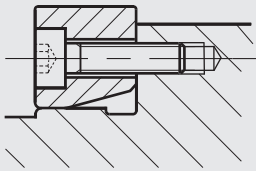
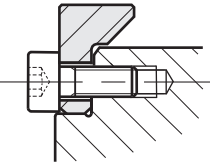
	Taper mount	Interference fit
'A' section		
'B' section	Not applicable	
Notes	<p>Recommended for all installations</p> <ul style="list-style-type: none"> • Enables simplest adjustment. • Offers highest accuracy. • Enables eccentricity to be compensated. • Offers excellent mechanical stability against thermal cycling, shock and vibration. • Minimises cost of substrate preparation. 	<p>Alternative installation</p> <ul style="list-style-type: none"> • Will not correct eccentricity of the supporting shaft.

Equipment required for taper mounting the RESA30 'A' section ring

Required parts:

- Appropriate RESA 'A' section ring (see '[RESA30 'A' section ring dimensions](#)' on page 27)
- Appropriate number of screws for ring size (see '[RESA30 'A' section ring dimensions](#)' on page 27)

NOTE: Recommended screw type M3 × 0.5 and must comply with ISO 4762/DIN 912 grade 10.9 minimum/ANSI B18.3.1M with a CTE of 10 to 16 µm/m/°C @ 20 °C.

- Dial Test Indicator (DTI)
- Appropriate cleaning solvents (see '[Storage and handling](#)' on page 19)
- Hex key
- Torque wrench

Optional parts:

- Renishaw scale wipes (A-9523-4040)
- Lint-free cloth

RESA30 'A' section ring taper mounting

Dimensions and tolerances in mm

Mounting shaft specifications

Recommended taper roundness:

Diameter	Roundness value (TIR)
≤ 115	0.025
150 to 225	0.050
≥ 300	0.075

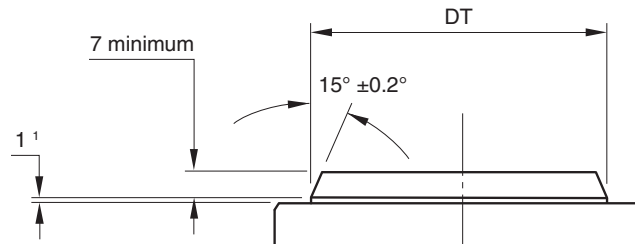

Recommended taper diameter (DT):

DO	DT	DO	DT	DO	DT	DO	DT	DO	DT
52	33.85 33.65	103	83.85 83.65	172	155.85 155.65	229	212.85 212.65	350	333.85 333.65
57	40.85 40.65	104	83.85 83.65	183	166.85 166.65	255	238.85 238.65	413	395.85 395.65
75	58.85 58.65	115	98.85 98.65	200	183.85 183.65	280	263.85 263.65	417	383.85 383.65
100	83.85 83.65	124	107.85 107.65	206	189.85 189.65	300	283.85 283.65	489	454.85 454.65
101	83.85 83.65	150	133.85 133.65	209	189.85 189.65	330	313.85 313.65	550	513.85 513.65

DO = Nominal external diameter.

Recommended surface finish ≤ Ra 1.2.

NOTE: It is recommended that the mounting surface is a turned, rather than ground finish.

¹ Allow 2 mm for 417 mm, 489 mm and 550 mm rings only.

- Remove the protective film from the surface of the RESA30 ring.
- Clean shaft taper and internal taper of RESA30 as recommended in 'Storage and handling' on page 19.

Step 1

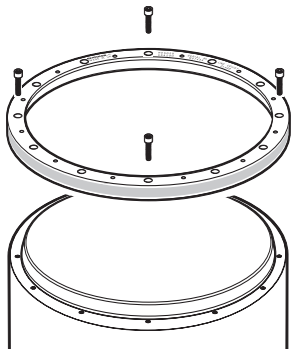

- Insert the first screws
 - For RESA30 rings with 6, 9 or 18 mounting holes, use 3 equally-spaced M3 screws.
 - For RESA30 rings with 12, 16 or 20 mounting holes, use 4 equally-spaced M3 screws.

NOTES:

- Do not lubricate screws.
 - Do not use a locking compound.
 - The recommended thread engagement is 6 mm.
-

- Insert the screws so that the RESA30 is loosely connected to the shaft, then roughly align the ring by eye and touch.
- Lightly tighten the screws. Use a Dial Test Indicator (DTI) to check the radial displacement at the screw locations.

NOTE: Disregard the radial displacement between the screw locations.

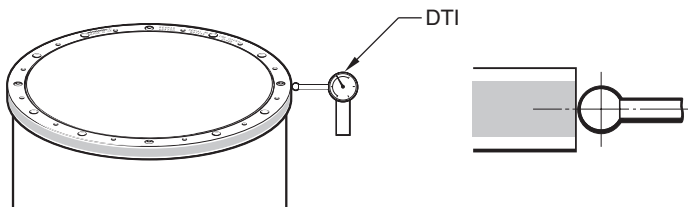

Use a DTI with low exertion force to avoid scratching the scale surface. A DTI with a ruby ball stylus is recommended as a further precaution against scratches.

- Adjust the screws to reduce the range of radial displacement. When adjusting, identify the screw location with the lowest radial displacement and tighten that screw, aiming for the average of the highest and lowest indicator readings.
- Repeat this process until the DTI readings are within $\pm 5 \mu\text{m}$ at the screw locations.

NOTE: It may be necessary to loosen screws whilst tightening other screws.

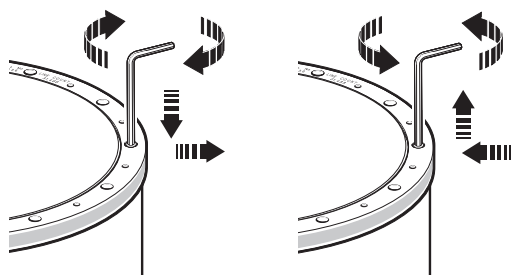

NOTE: At this stage, the screws should only be lightly tightened (less than 0.5 Nm) to allow further final adjustment.

Step 2

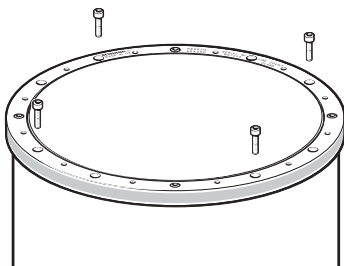

- Insert the next screws:
 - For RESA30 rings with 6, 9 or 12 mounting holes, insert all the remaining M3 screws.
 - For RESA30 rings with 16 mounting holes, insert 4 equally-spaced M3 screws.
 - For RESA30 rings with 18 mounting holes, insert 6 equally-spaced M3 screws.
 - For RESA30 rings with 20 mounting holes, insert 8 equally-spaced M3 screws (in four groups of two) between existing screws.
- As described in Step 1, adjust all the screws already inserted, so that the radial displacement at each screw location is within $\pm 5 \mu\text{m}$.
- Again, at this stage, the screws should only be lightly tightened (less than 0.5 Nm).

NOTE: The torque required to achieve the radial displacement tolerance may be slightly higher during step 2 than during step 1.

Step 3

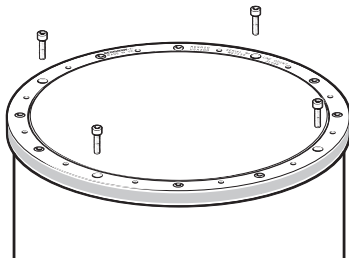

- Insert screws into the remaining mounting holes.

Step 4

Diameter (mm)	Recommended torque range (Nm)
≤ 115	1.5 - 2.1
150 to 255	0.8 - 1.1
300 to 413	0.5 - 0.7
≥ 417	1.2 - 1.7

- Rotate the RESA30 ring, measuring the radial displacement at all of the screw locations.
- Tighten the screw with the lowest radial displacement so that it matches the average radial displacement, whilst ensuring the maximum torque specified in the table is not exceeded.
- Again, rotate the RESA30 ring and re-check the radial displacement at all of the screw locations, tightening the screw with the lowest radial displacement so that it matches the average.
- Repeat this process until the radial displacement at all of the screw locations is within $\pm 3 \mu\text{m}$ and that all screw torques are within the specified range.
- Excessive tightening of screws can have a small effect on accuracy. Contact your local Renishaw representative for more details.
- Clean the ring using Renishaw scale cleaning wipes or a clean, dry, lint-free cloth.

Equipment for interference fit mounting the RESA30 'A' section and RESA30 'B' section rings

Required parts:

- Appropriate RESA 'A' or 'B' section ring (see '[RESA30 'A' section ring dimensions](#)' on page 27 or '[RESA30 'B' section ring dimensions](#)' on page 29)
- Appropriate number of screws for ring size (see '[RESA30 'A' section ring dimensions](#)' on page 27 or '[RESA30 'B' section ring dimensions](#)' on page 29)

NOTE: Recommended screw type M3 × 0.5 and must comply with ISO 4762/DIN 912 grade 10.9 minimum/ANSI B18.3.1M with a CTE of 10 to 16 µm/m/°C @ 20 °C.

- Appropriate cleaning solvents (see '[Storage and handling](#)' on page 19)
- Hex key
- Torque wrench

Optional parts:

- Renishaw scale wipes (A-9523-4040)
- Lint-free cloth

RESA30 ‘A’ section and RESA30 ‘B’ section ring interference fit mounting

- Remove the protective film from the surface of the RESA ring.
- Clean the mounting faces of the shaft and the RESA as recommended in ‘Storage and handling’ on page 19.
- Place the RESA30 ring on the shaft.

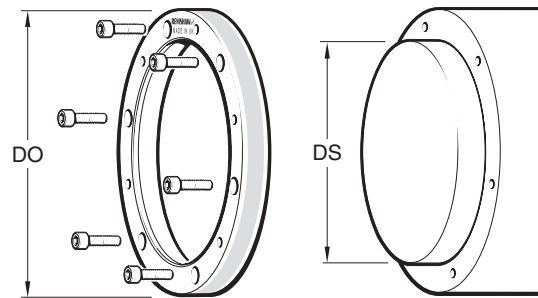

- Insert screws into all mounting holes.
- Tighten all screws.
- Clean ring using Renishaw scale cleaning wipes or a clean, dry, lint-free cloth.

NOTES:

- Do not lubricate the screws.
- Do not use a locking compound.
- Ensure that all screws are tightened to 1.8 Nm.
- The recommended thread engagement is 6 mm.
- 417, 489 and 550 mm rings should be taper mounted only.

¹ 52 mm ‘B’ section ring **DS (mm)** = $\begin{matrix} 32.033 \\ 32.017 \end{matrix}$

² Only available as a ‘B’ section ring.

Recommended shaft diameter (DS):

DO (mm)	DS (mm)	DO (mm)	DS (mm)
52 ¹	30.033	183	163.052
	30.017		163.027
57	37.033	200	180.052
	37.017		180.027
75	55.039	206	186.060
	55.020		186.031
100	80.045	209	186.060
	80.023		186.031
101	80.045	229	209.060
	80.023		209.031
103	80.045	255	235.060
	80.023		235.031
104	80.045	280	260.066
	80.023		260.034
115	95.045	300	280.066
	95.023		280.034
124	104.045	330	310.066
	104.023		310.034
150	130.052	350	330.073
	130.027		330.037
165 ²	145.052	413	392.073
	145.027		392.037
172	152.052		
	152.027		

DO = Nominal external diameter

REXA30 ring specifications

The REXA ring scale must be installed and operated with the following specifications.

Installation temperature	20 ±5 °C
Operating temperature range	0 °C to 80 °C
Mounting shaft coefficient of thermal expansion at 20 °C	14.5 to 16.5 µm/m/°C

REXA30 ring flange mount

Safety factor	2
Safe position	±1 mm

Ring diameter (mm)	Maximum permissible speed (rpm)	Mechanical safe position (°)
52	7 500	2.204
57	6 400	2.010
75	5 900	1.528
100	3 900	1.146
103	3 700	1.113
104	3 600	1.102
115	3 200	0.996
150	2 300	0.764
183	2 000	0.626

Ring diameter (mm)	Maximum permissible speed (rpm)	Mechanical safe position (°)
200	1 800	0.573
206	1 700	0.556
209	1 700	0.548
229	1 500	0.500
255	1 300	0.449
300	1 000	0.382
350	970	0.327
417	740	0.275

NOTE: The 'Mechanical Safe Position' is the maximum distance the scale might move from its installed position and will be undetected by the readhead.

REXA30 ring installation drawing

Dimensions and tolerances in mm

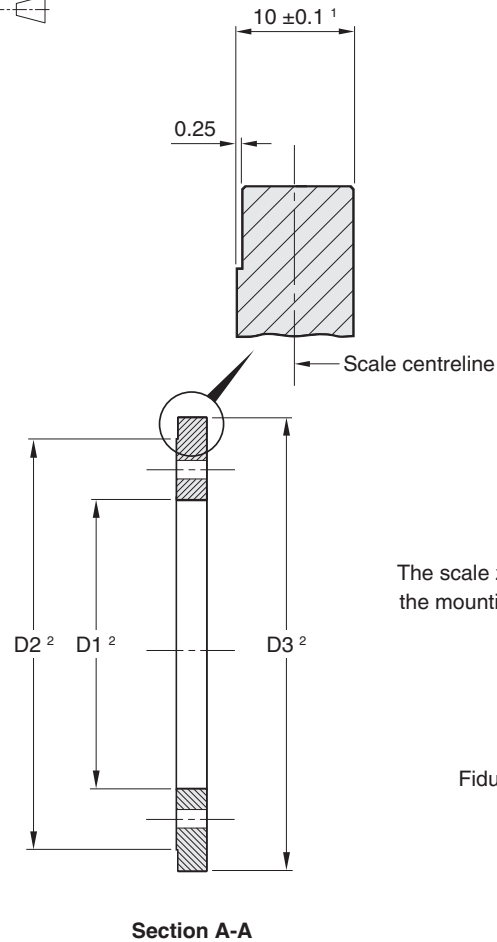

The scale zero is radially aligned with the centre of the mounting hole to the left of the 'Renishaw' logo

Fiducial marks, 4 positions, to aid installation

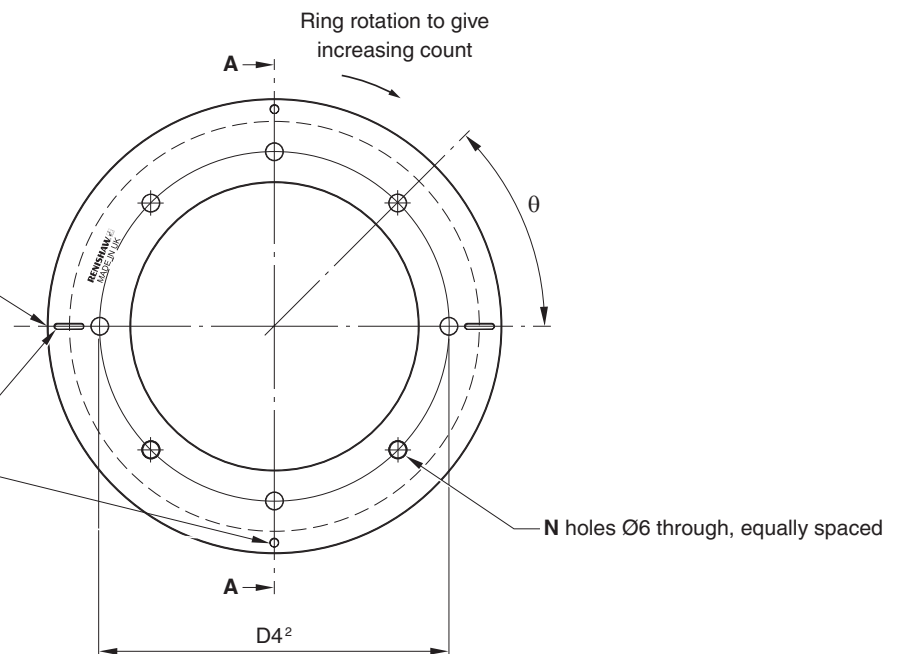

¹ Graduations are centered within this dimension.

² The dimensions D1, D2, D3 and D4 for the REXA rings are listed on the following page.

REXA30 ring dimensions

Nominal external diameter	Dimensions			Mounting holes		
	D1	D2	D3	D4	N	θ
52 ¹	26	50	52.1 - 52.2	38	4	90°
57 ¹	26	50	57.25 - 57.35	38	4	90°
75	40.5	64.5	75.3 - 75.4	52.5	8	45°
100	57.5	97.5	100.2 - 100.3	77.5	8	45°
103	57.5	97.5	103.0 - 103.2	77.5	8	45°
104	57.5	97.5	104.2 - 104.4	77.5	8	45°
115	68	108	114.5 - 114.7	88	8	45°
150	96	136	150.2 - 150.4	116	8	45°
183	122.5	162.5	183.2 - 183.4	142.5	12	30°
200	136	176	200.2 - 200.4	156	12	30°
206	140.5	180.5	206.1 - 206.5	160.5	12	30°
209	140.5	180.5	208.4 - 208.8	160.5	12	30°
229	160.5	200.5	229.0 - 229.4	180.5	12	30°
255	180.5	220.5	254.4 - 254.8	200.5	12	30°
300	216	256	300.2 - 300.4	236	12	30°
350	256	296	350.2 - 350.4	276	16	22.5°
417	305	345	417.0 - 417.4	325	16	22.5°

IMPORTANT: RESOLUTE Functional Safety readheads must be used with the correct size REXA ring. Ensure matching part numbers when ordering.

¹ 52 mm and 57 mm rings have dimple fiducial features and no slots.

Equipment for flange mounting the REXA30 ring

Required parts:

- Appropriate REXA ring (see 'REXA30 ring dimensions' on page 40)
- Appropriate number of screws for ring size (see 'REXA30 ring dimensions' on page 40)

NOTE: Recommended screw type M5 × 0.8 and must comply with ISO 4762 / DIN 912 grade 10.9 minimum / ANSI B18.3.1M with a CTE of 10 to 16 µm/m/°C @ 20 °C.

- Dial Test Indicator (DTI)
- Rubber mallet
- Appropriate cleaning solvents (see 'Storage and handling' on page 19)
- Hex key
- Torque wrench

Optional parts:

- Renishaw scale wipes (A-9523-4040)
- Lint-free cloth

REXA30 ring flange mounting

- The REXA30 ring should be flange mounted onto a flat surface to minimise 2-per-rev distortion.
- Taper mounting is not suitable for thick cross-section REXA rings.
- To avoid distorting to the scale, the REXA should not be interference fitted.
- Some eccentricity of the ring is acceptable because it will be compensated using two readheads.

Dimensions and tolerances in mm

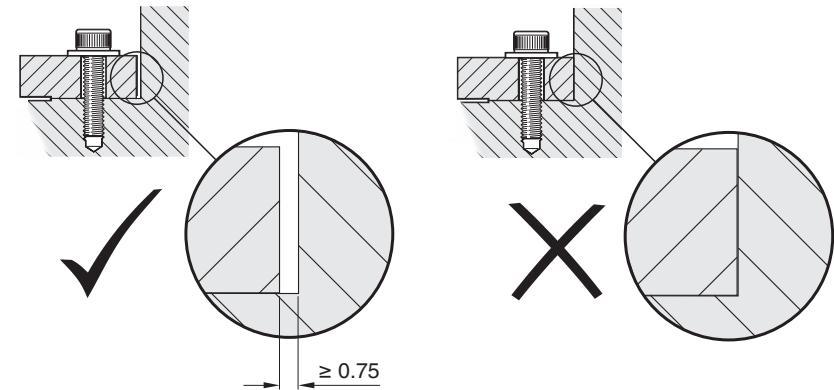

Mounting shaft preparation

There is a mounting face on the lower side of the REXA30 ring (diameter D2).

A flat surface should be prepared on the mounting shaft to match.

The total axial run-out of the mounting surface should be within 10 µm.

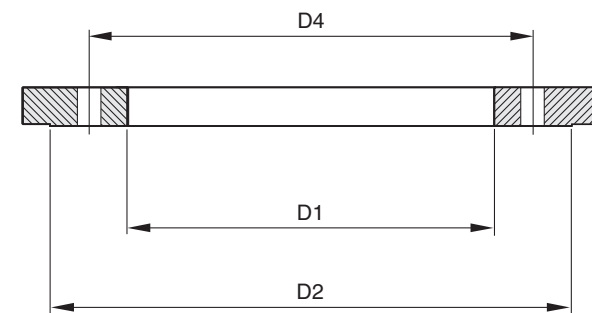
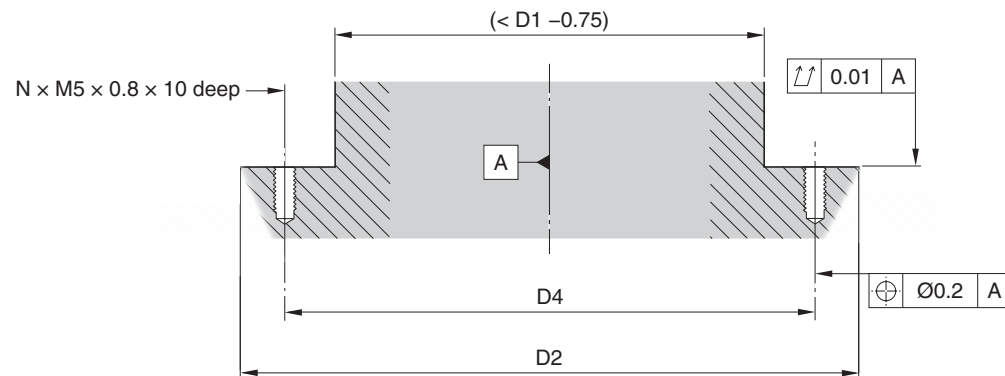

For dimensions D1, D2, D4 and number of holes N, refer to 'REXA30 ring dimensions' on page 40.

Mounting the REXA30 ring

- Clean the mounting face on the lower side of the REXA (see 'Storage and handling' on page 19).
- Clean the mating surface on the mounting shaft (see 'Storage and handling' on page 19).
- Place the REXA onto the mounting shaft, then insert four off M5 screws with flat washers into the four screw holes by the fiducial marks.

IMPORTANT: Do not tighten the screws at this point; simply engage the threads ensuring that the heads do not touch the ring.

- The recommended thread engagement is 10 mm.

NOTES:

- Do not lubricate screws.
 - Do not use a locking compound.
-

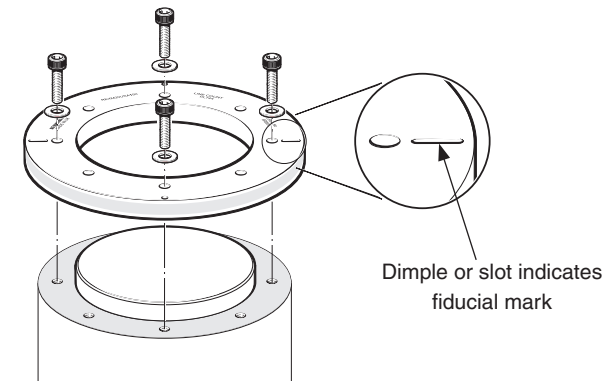

Adjusting the REXA30 ring

Step 1

- Remove the protective film from the surface of the REXA.
- Measure the run-out on the REXA ring using a Dial Test Indicator (DTI) to. Use a DTI with low exertion force to avoid scratching the scale surface. A DTI with a ruby ball stylus is recommended as a further precaution against scratches.

NOTE: At this stage the ring is not firmly fixed, so to avoid causing the ring to shift position, rotate the ring slowly and smoothly.

- Where the DTI shows the lowest radius reading, gently tap the opposite side of the ring on the edge using a rubber mallet, until the DTI reading is approximately at the 'mid-point' of the run-out.
- Find the new lowest radius reading.
- Tap the opposite side of the ring with a rubber mallet until the DTI reading is at the 'mid-point' of the run-out.
- Repeat this process until the run-out of the ring is approximately 30 μm TIR (0.0012 inches).

Step 2

- Adjust ring position until the DTI (dial test indicator) reading at these points agrees to 10 μm TIR.

NOTE: 52 mm and 57 mm rings do not have 'slot' fiducials marked.

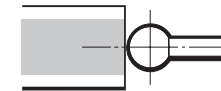
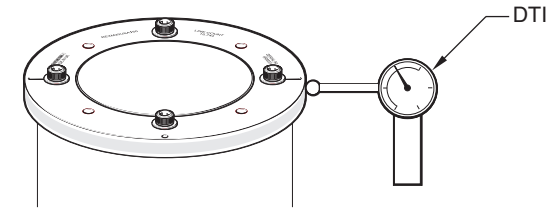
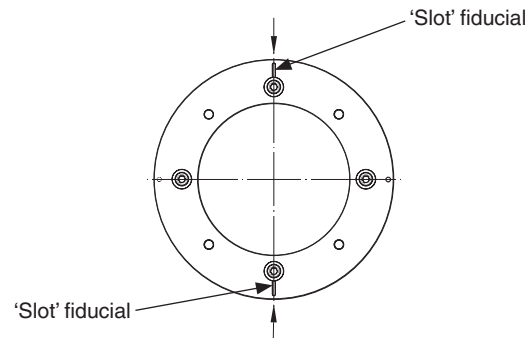

Use a DTI with low exertion force to avoid scratching the scale surface. A DTI with a ruby ball stylus is recommended as a further precaution against scratches.

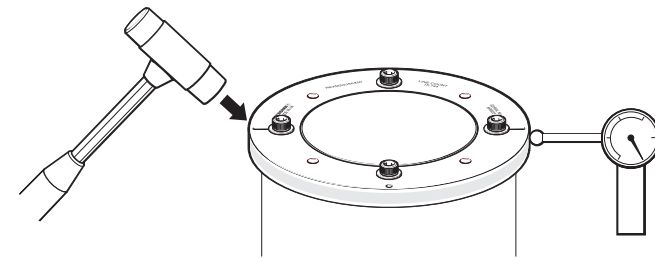

Step 3

- Rotate the ring by 90°.
- Adjust the ring position until the DTI (dial test indicator) reading at these points agrees to 10 µm TIR.

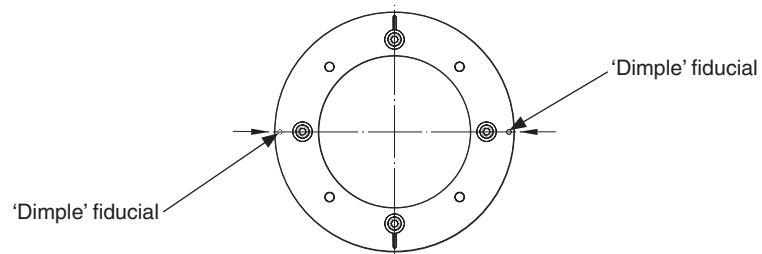

Step 4

- Re-check the run-out at the two 'slot' fiducial points, to ensure the run-out is still within 10 µm TIR. Adjust if necessary.
- Gradually tighten the 4 screws in turn, enough to grip and lightly secure the ring so as to avoid moving the position of the ring.
- Insert the remaining M5 screws and, in a sequential pattern, gradually tighten them to a torque of 7 Nm.
- Re-check the run-out at the two 'slot' fiducial points, then at the two 'dimple' fiducial points.

NOTE: The run-out values at the 'slot' fiducial points do not have to match the run-out values at the 'dimple' fiducial points.

- If the ring has moved position outside the 10 µm limit, the screws must be loosened and the ring adjusted.

Siemens DRIVE-CLiQ dual head installation

Accuracy

The dual head interface is designed for use with two RESOLUTE readheads and REXA30 ring only. It compensates for the effect of bearing wander and eliminates all odd error harmonics including eccentricity. However, 'even' error harmonics such as ovality remain. This results in high angular accuracy to ± 1 arc second, as shown in the accompanying table.

REXA30 diameter	Total installed accuracy (with 2 readheads)
≥ 100 mm	± 1 arc second
75 mm	± 1.5 arc second
≤ 57 mm	± 2 arc second

For optimum accuracy performance, the readheads should be diametrically opposite each other so that the optical centre lines are 180° apart. However if this is not possible due to mounting constrictions, or for partial arc applications, the readheads should be mounted as close to this as possible; contact your local Renishaw representative to find out what accuracy you can expect if this is the case.

Interface output

For readheads (RH1 and RH2) mounted such that the angle between them is θ .

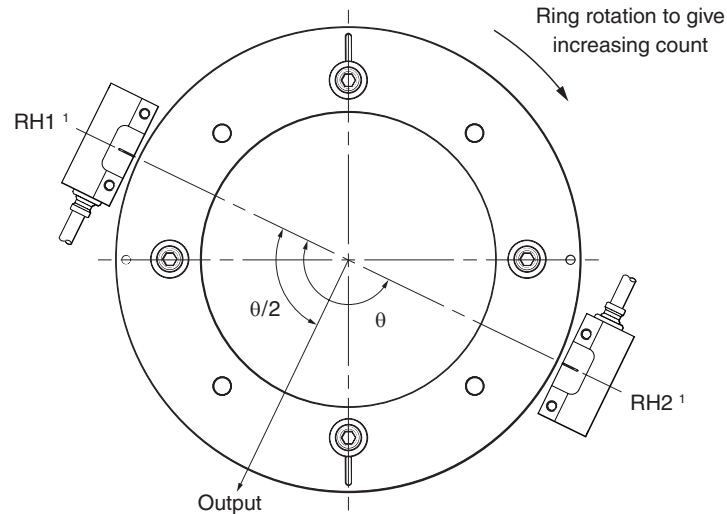

The dual head DRIVE-CLiQ interface takes simultaneous readings from both readheads and calculates the mean of them. The output is therefore at an angle of $\theta/2$ and is in the position shown when the scale is orientated with increasing count as shown.

¹ The readheads can be mounted in any orientation

Summary of procedure

Install both readheads on mounting surfaces.



Connect both readheads to dual head interface and connect interface to controller.



Supply power to the controller and interface, adjust each readhead such that both readheads have good signal levels around the ring (green or blue indication).



Acknowledge any errors on the controller that may have occurred during installation.

Linear RESOLUTE readhead installation drawing – standard cable outlet

Dimensions and tolerances in mm



- 1 Extent of mounting faces.
- 2 The recommended thread engagement is 6 mm minimum (9 mm including counterbore) and the recommended tightening torque is 0.9 Nm to 1.1 Nm.
- 3 Offset and rideheight vary depending upon scale type:

Scale type	Offset	Rideheight
RELA30/RSLA30	0.8 ±1	0.8 ±0.15
RTLA30-S	4.25 ±1	0.8 ±0.15
RTLA30/FASTRACK	0.75 ±1	0.6 ±0.12

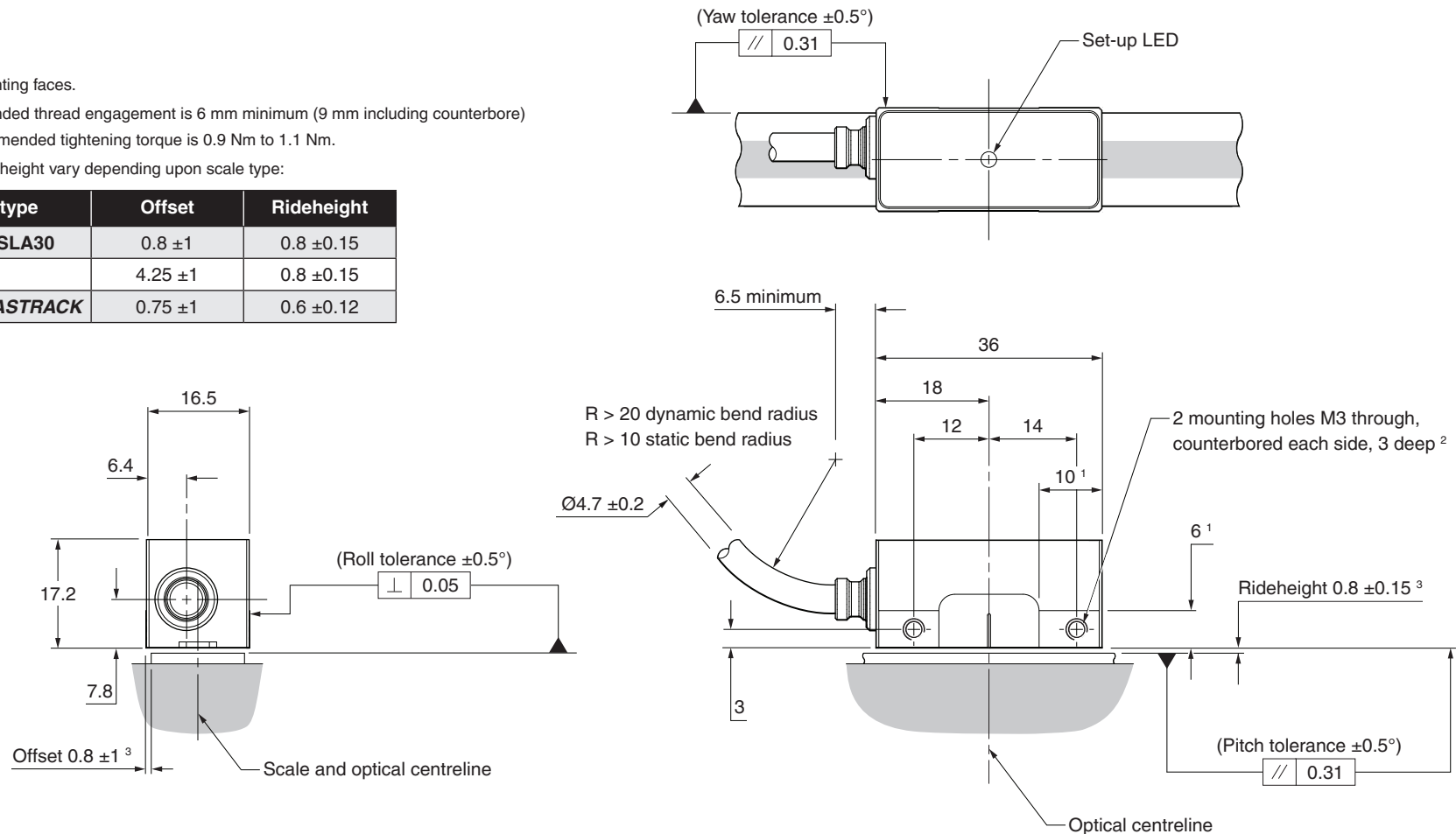

NOTE: RESOLUTE readhead shown on RELA30 spar scale.

Linear RESOLUTE readhead installation drawing – side cable outlet

Dimensions and tolerances in mm



- 1 Extent of mounting faces.
- 2 The recommended thread engagement is 6 mm minimum (9 mm including counterbore) and the recommended tightening torque is 0.9 Nm to 1.1 Nm.
- 3 Offset and rideheight vary depending upon scale type:

Scale type	Offset	Rideheight
RELA30/RSLA30	0.8 ±1	0.8 ±0.15
RTLA30-S	4.25 ±1	0.8 ±0.15
RTLA30/FASTRACK	0.75 ±1	0.6 ±0.12

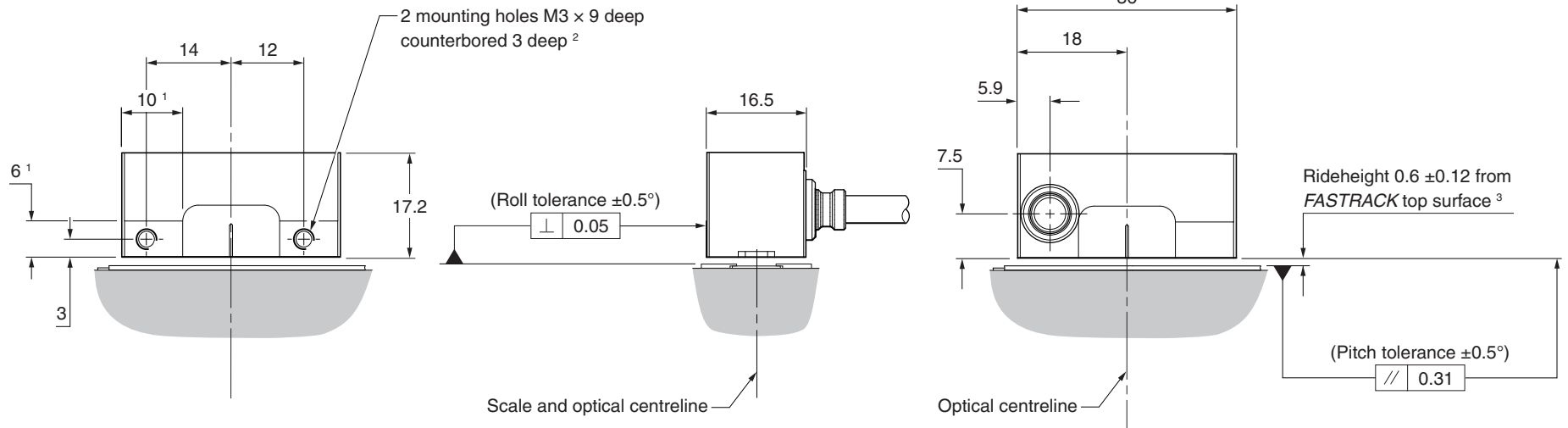
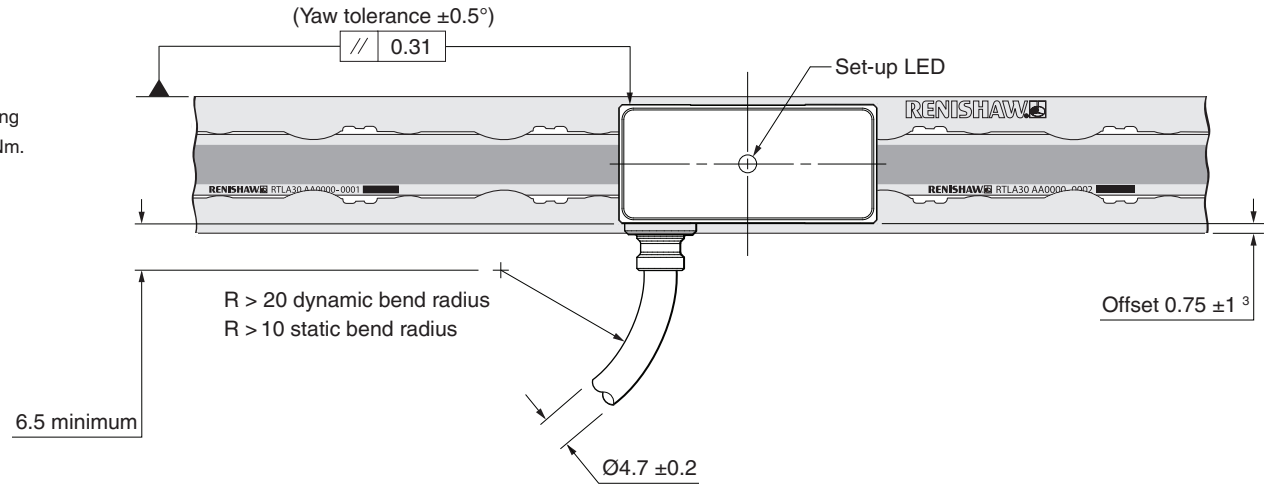

NOTE: RESOLUTE readhead shown on RTLA30/FASTRACK scale system.

RELA30/RSLA30 spar scale technical specifications

RELA30

Form (height x width)	1.8 mm x 14.9 mm (including adhesive backing tape)
Mounting	Adhesive backing tape
Datum fixing	RGG-2 epoxy (A-9531-0342) datum point
Material	ZeroMet™. High stability low-expansion nickel-iron alloy
Installation temperature	20 ±5 °C
Operating temperature range	0 °C to 80 °C
Accuracy (at 20 °C)	Certified to ±1 µm for lengths up to 1 m (includes slope and linearity). ±1 µm/m for lengths > 1 m to 1.5 m. Calibrated traceable to International Standards.
Coefficient of thermal expansion (at 20 °C)	0.75 ±0.35 µm/m/°C
Maximum length	1.5 m
Mass	184 g/m

RSLA30

Form (height x width)	1.7 mm x 14.9 mm (including adhesive backing tape)
Mounting	Adhesive backing tape
Datum fixing	RGG-2 epoxy (A-9531-0342) datum point
Material	Hardened martensitic stainless steel
Installation temperature	20 ±5 °C
Operating temperature range	0 °C to 80 °C
Accuracy (at 20 °C)	±1.5 µm up to 1 m ±2.25 µm from 1 m to 2 m ±3 µm from 2 m to 3 m ±4 µm from 3 m to 5 m (includes slope and linearity) calibration traceable to International Standards.
Coefficient of thermal expansion (at 20 °C)	10.1 ±0.2 µm/m/°C
Maximum length	5 m
Mass	172 g/m

RELA30/RSLA30 scale installation drawing

Dimensions and tolerances in mm

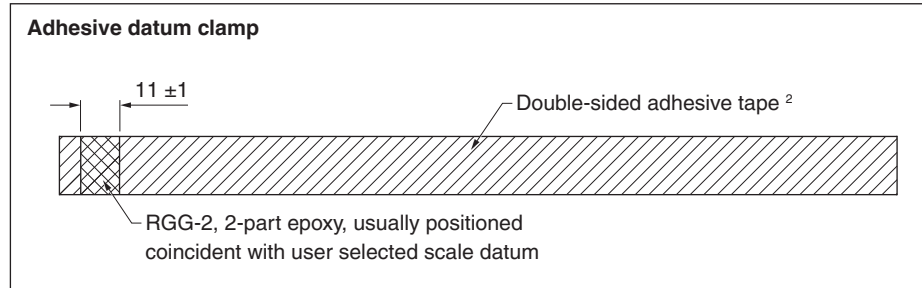
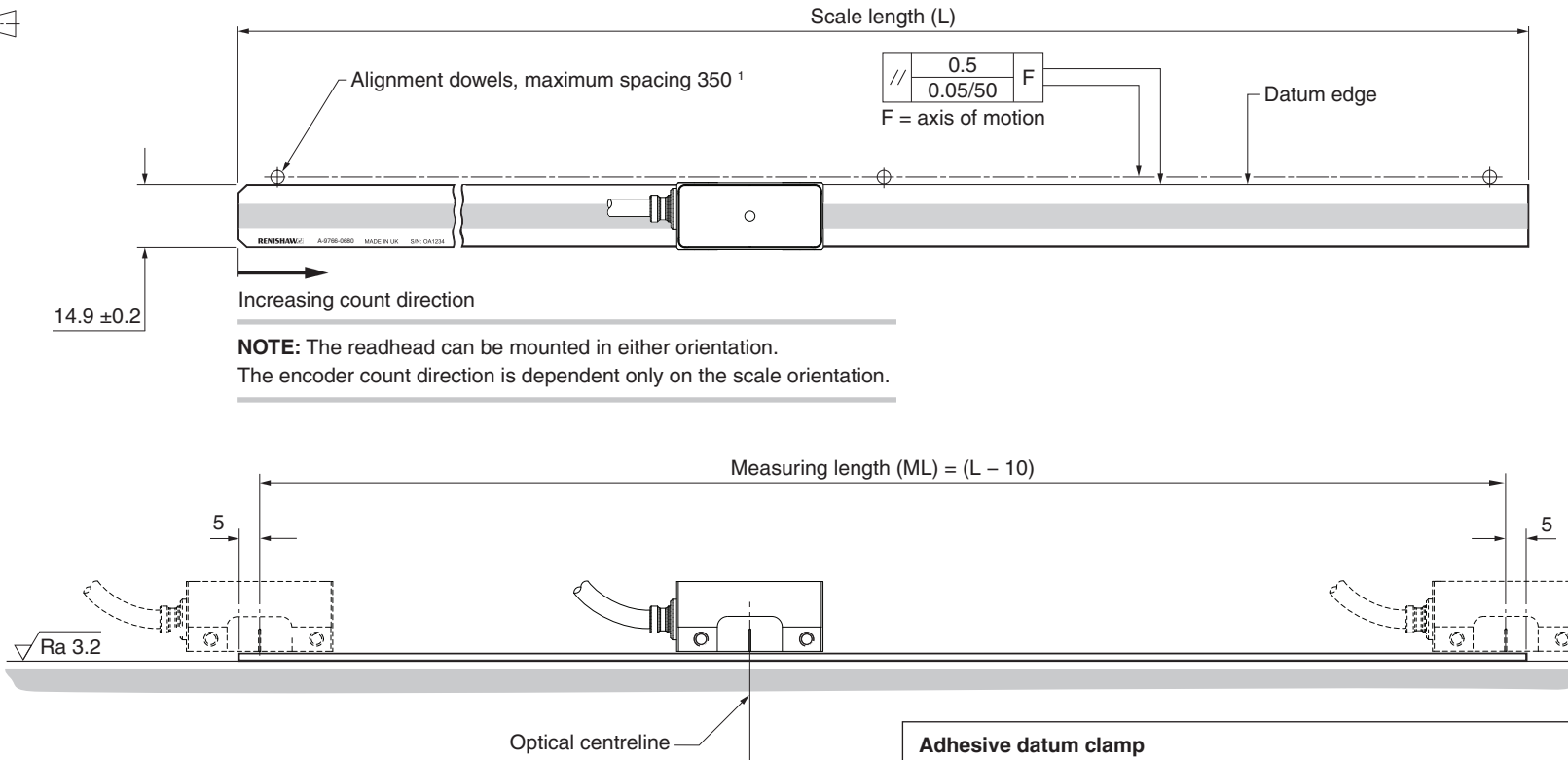

NOTES:

- Adhesive mounted scale should not be reused after installation.
- RELA30 shown. RSLA30 installation is the same but the scale has no chamfers.

¹ When the scale is to be mounted vertically, position the dowels so that the datum edge is supported.

² Double-sided adhesive tape is included with all scale lengths.

Equipment required for adhesive mounting the RELA30/RSLA30 spar scale

Required parts:

- RELA30 or RSLA30 spar scale (see '[RELA30/RSLA30 scale installation drawing](#)' on page 50)
- RGG-2 two part epoxy adhesive (A-9531-0342)
- Appropriate cleaning solvents (see '[Storage and handling](#)' on page 19)
- Pencil or other appropriate marker
- Scissors

Optional parts:

- Renishaw scale wipes (A-9523-4040)
- Lint-free cloth

Installing the adhesive mounted RELA30/RSLA30 scale

1. Thoroughly clean and degrease the substrate with a lint-free cloth and clean the underside of the scale using approved solvents (see 'Storage and handling' on page 19).

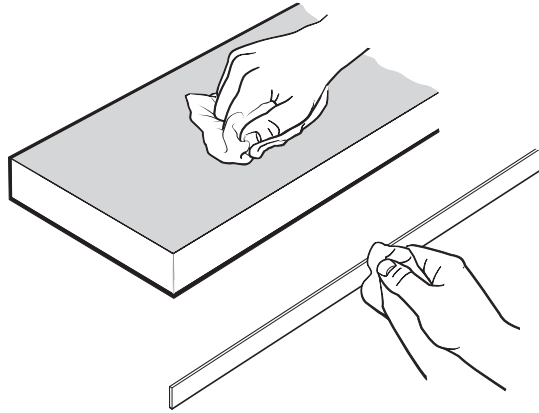

3. Remove the backing liner from one side of the adhesive tape and stick it to the underside of the scale.

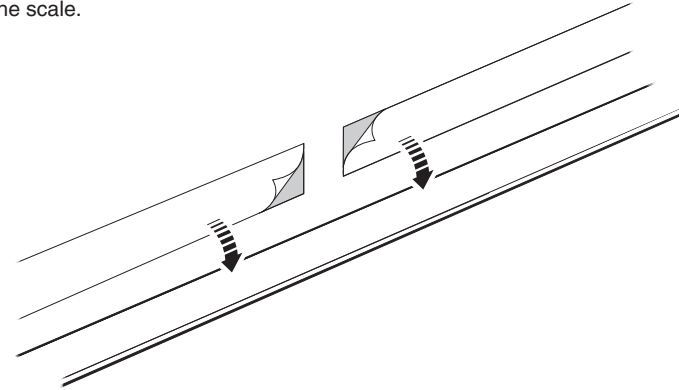

2. Mark the area for epoxy on the adhesive tape and cut the tape accordingly. The epoxy datum clamp fixes the scale rigidly to the substrate at the chosen location.

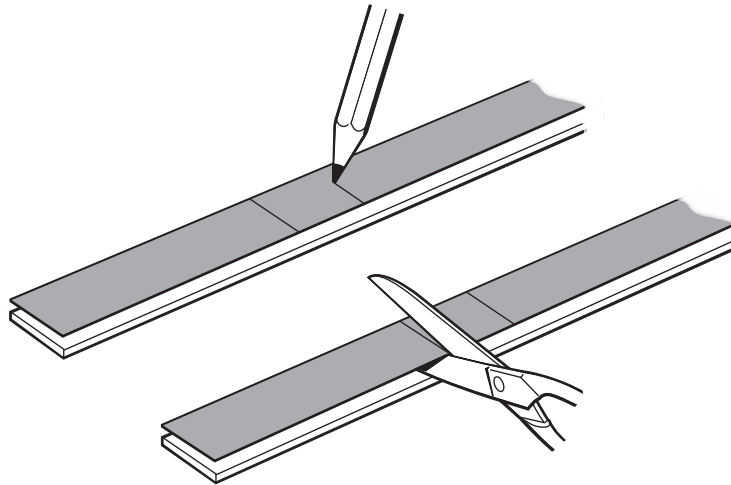

4. Thoroughly mix and apply the epoxy to the back of the scale and then remove the remaining backing liner.

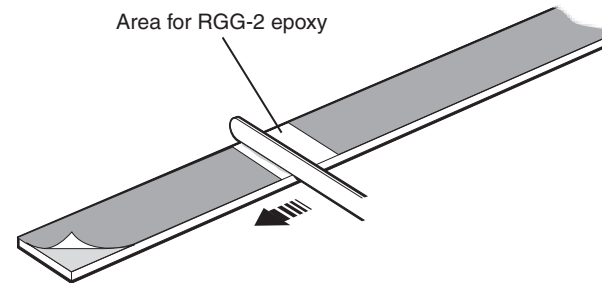

5. Locate the scale against dowels or a ledge and rotate it down onto the substrate. Press down with firm finger pressure.

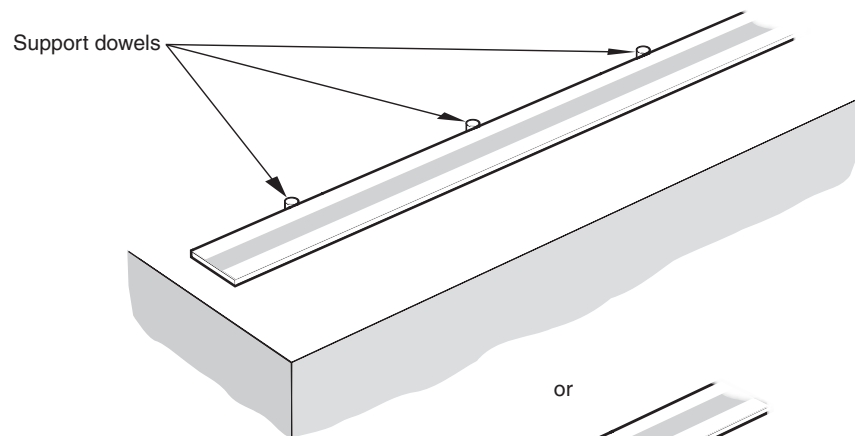
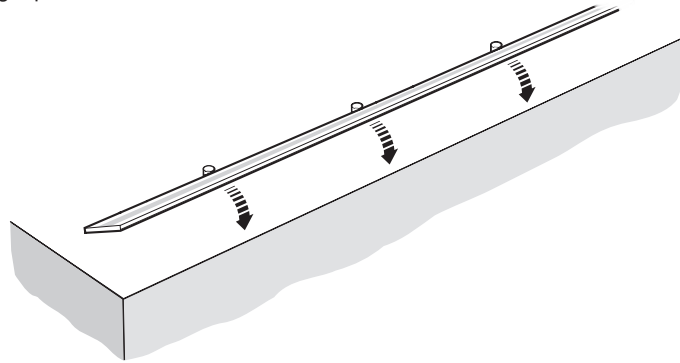

or

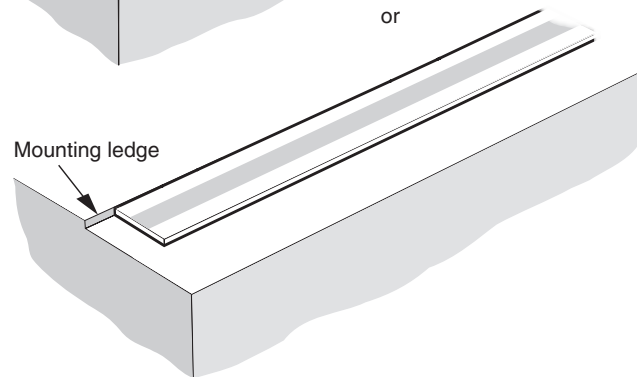

6. Remove any excess epoxy.

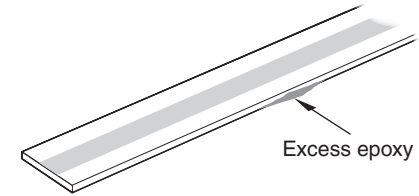

7. Allow 24 hours for the epoxy to cure fully and then clean the scale using Renishaw scale wipes or a clean, dry, lint-free cloth.

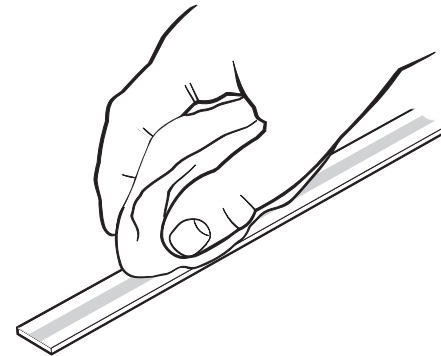

RTLA30-S scale technical specifications

Form (height x width)	0.4 mm x 8 mm (including adhesive)	
Mounting	Adhesive backing tape (nominal thickness 0.2 mm)	
Datum fixing	Datum clamp (A-9585-0028) secured with Loctite® 435™ (P-AD03-0012)	
Material	Hardened and tempered martensitic stainless steel	
Installation temperature	20 ±5 °C	
Operating temperature range	0 °C to 80 °C	
Accuracy (at 20 °C)	±5 µm/m, calibration traceable to International Standard	
Coefficient of thermal expansion (at 20 °C)	10.1 ±0.2 µm/m/°C	
Maximum length	50 nm resolution readhead	13.42 m
	1 nm resolution readhead	17.18 m
Mass	184 g/m	

RTLA30-S scale installation drawing

Dimensions and tolerances in mm

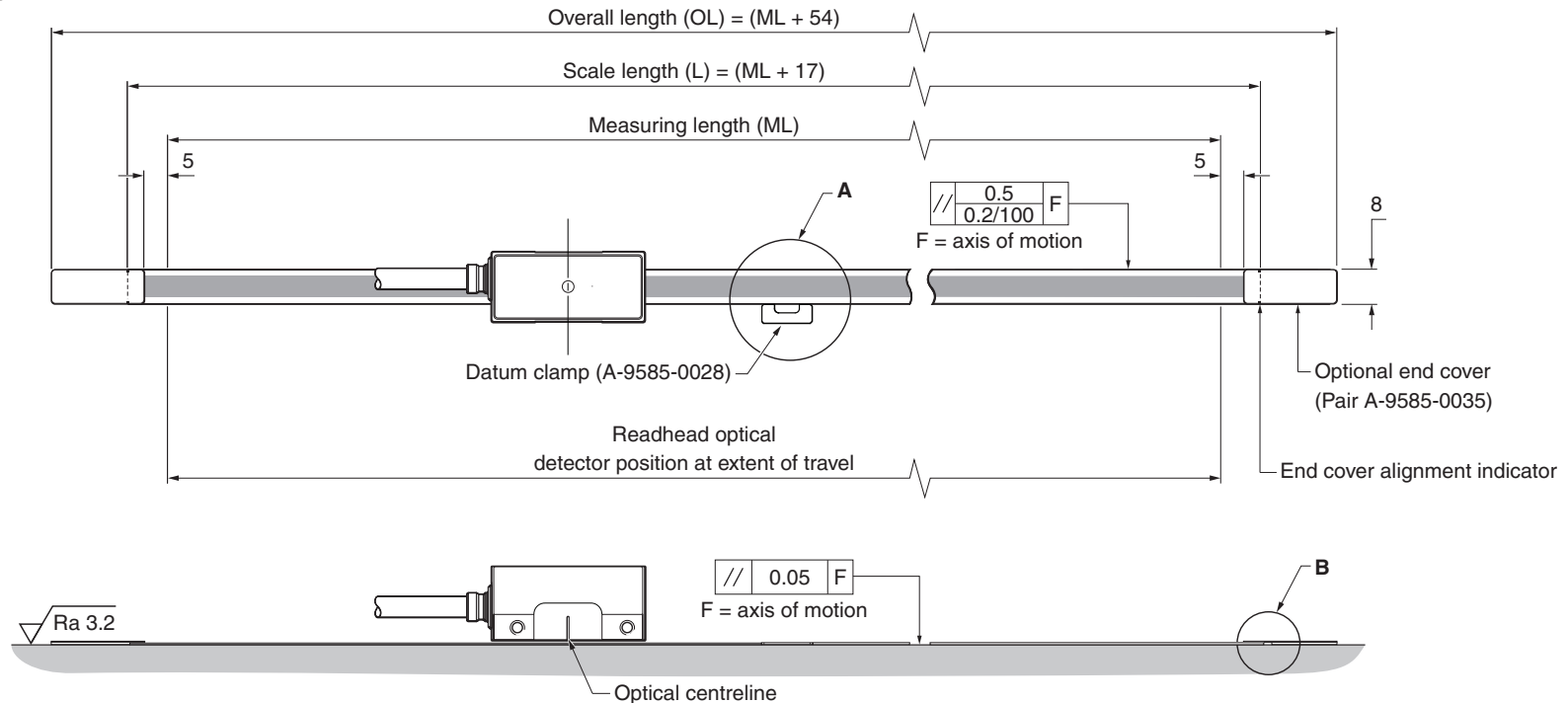

The orientation of the scale determines the count direction



Moving the readhead in this direction increases the count

Moving the readhead in this direction increases the count

NOTE: Reversing the readhead orientation has no effect on the count direction

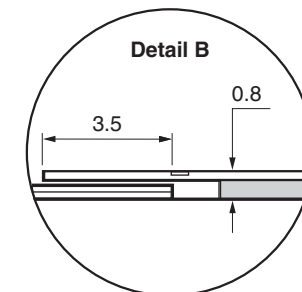
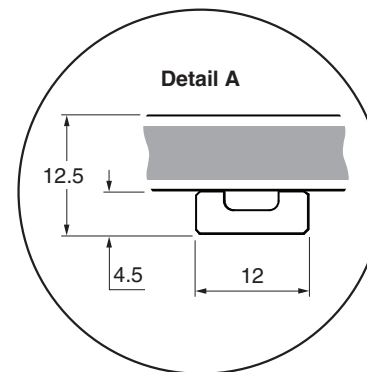

Equipment required for installing the RTLA30-S scale

Required parts:

- RTLA30-S scale (see '[RTLA30-S scale installation drawing](#)' on page 55)
- Datum clamp (A-9585-0028)
- Loctite® 435™ (P-AD03-0012)
- Appropriate cleaning solvents (see '[Storage and handling](#)' on page 19)
- RTLA30-S scale applicator (A-9589-0095)
- 2 × M3 screws

Optional parts:

- Renishaw scale wipes (A-9523-4040)
- End cover kit (A-9585-0035)
- Lint-free cloth
- Loctite® 435™ dispensing tip (P-TL50-0209)
- Guillotine (A-9589-0071) or shears (A-9589-0133) for cutting RTLA30-S to required length

Cutting the RTLA30-S scale

If required cut the RTLA30-S scale to length using the guillotine or shears. Refer to the 'RTLA30-S scale installation drawing' on page 55.

Using the guillotine

The guillotine should be held securely in place, using a suitable vice or clamping method.

Once secured, feed the RTLA30-S scale through the guillotine as shown, and place guillotine press block down onto the scale.

NOTE: Ensure the block is in the correct orientation (as shown below).

Guillotine press block orientation when cutting the RTLA30-S scale

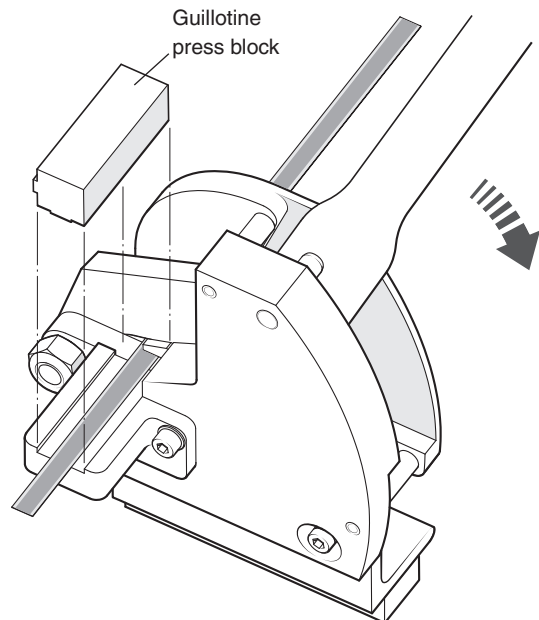

Whilst holding the block in place, in a smooth motion, pull down the lever to cut through the scale.

Using the shears

Feed the RTLA30-S scale through the middle aperture on the shears (as shown below).

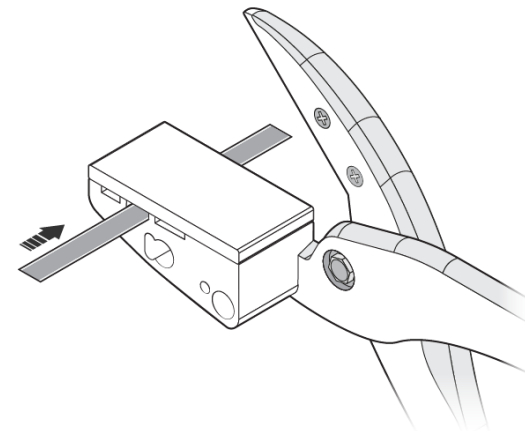

Hold the scale in place and close the shears in a smooth motion to cut through the scale.

Applying the RTLA30-S scale

1. Allow the scale to acclimatise to the installation environment prior to installation.
2. Mark out the start position for the scale on the axis substrate; ensure that there is room for the end covers if required (see 'RTLA30-S scale installation drawing' on page 55).
3. Thoroughly clean and degrease the substrate using recommended solvents (see 'Storage and handling' on page 19). Allow the substrate to dry before applying the scale.
4. Mount the scale applicator to the readhead mounting bracket. Place the shim supplied with the readhead between the applicator and the substrate to set the nominal height.

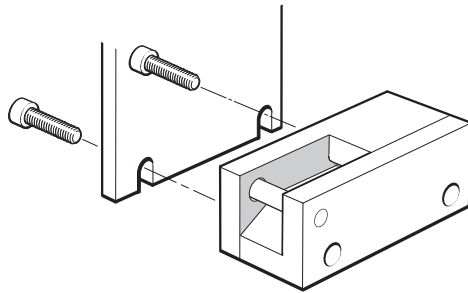

NOTE: The scale applicator can be mounted either way round to enable easiest orientation for the scale installation.

5. Move the axis to the start of travel leaving enough room for the scale to be inserted through the applicator, as shown below.
6. Begin to remove the backing paper from the scale and insert the scale into the applicator up to the start position. Ensure the backing tape is routed under the splitter screw.

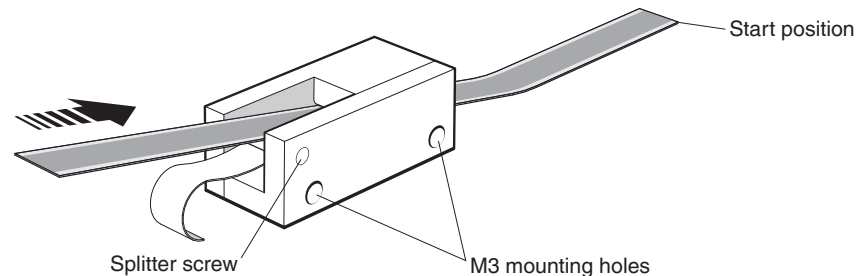

7. Apply firm finger pressure via a clean, dry, lint-free cloth to ensure the scale end adheres well to the substrate.
8. Slowly and smoothly move the applicator through the entire axis of travel. Ensure the backing paper is pulled manually from the scale and does not catch under the applicator.

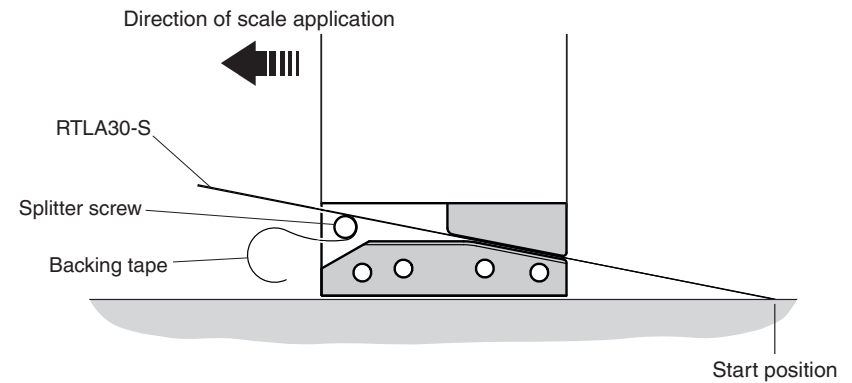

9. During installation ensure the scale is adhered to the substrate using light finger pressure.
10. Remove the applicator and, if necessary, adhere the remaining scale manually.
11. Apply firm finger pressure via a clean lint-free cloth along the length of the scale after application to ensure complete adhesion.
12. Clean the scale using Renishaw scale cleaning wipes or a clean, dry, lint-free cloth.
13. Fit the optional end covers (see 'Fitting the end covers' on page 59).
14. Allow 24 hours for complete adhesion of the scale before fitting the datum clamp (see 'Fitting the datum clamp' on page 59).

Fitting the end covers

The end cover kit is designed to be used with the RTLA30-S scale to provide protection for exposed scale ends.

NOTE: The end covers can be fitted before or after the readhead is installed.

1. Remove the backing tape from the adhesive tape on the back of the end cover.

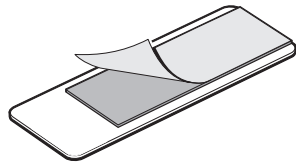

2. Align markers on the edges of the end cover with the end of the scale and place the end cover over the scale.

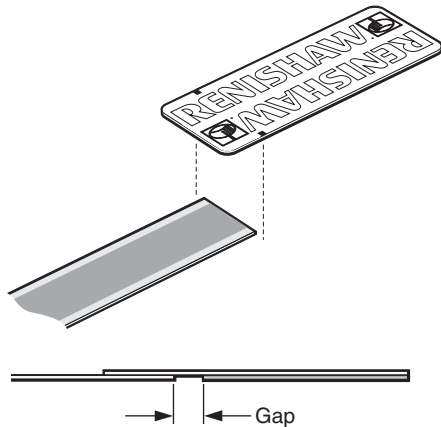

NOTE: There will be a gap between the end of the scale and the adhesive tape on the end cover.

Fitting the datum clamp

IMPORTANT: Allow 24 hours after scale application before fitting the datum clamp.

The datum clamp fixes the RTLA30-S scale rigidly to the substrate at the location chosen.

CAUTION: The metrology of the system may be compromised if the datum clamp is not used.

It can be positioned anywhere along the axis depending upon the customers' requirements.

1. Remove the backing paper from the datum clamp.
2. Place the datum clamp with cut-out against the scale at the chosen location.

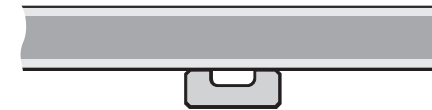

3. Place a small amount of adhesive (Loctite® 435™) in the cut-out on the datum clamp, ensuring none of the adhesive wicks onto the scale surface. Dispensing tips for the adhesive are available.

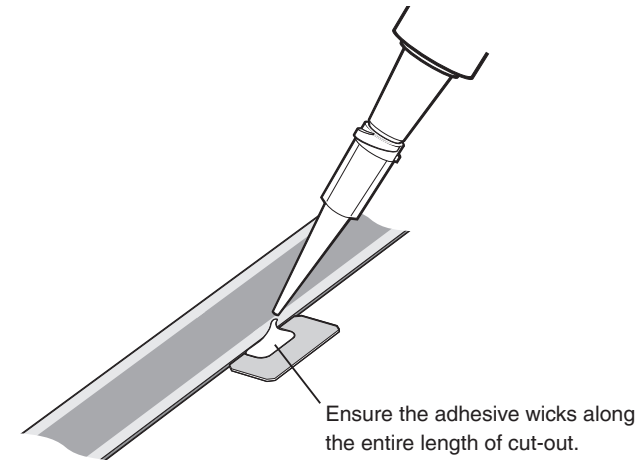

RTLA30/*FASTRACK* scale system technical specifications

RTLA30 scale

Form (height × width)	0.2 mm × 8 mm
Mounting	Held within the <i>FASTRACK</i> carrier
Datum fixing	Loctite® 435™ (P-AD03-0012)
Material	Hardened and tempered martensitic stainless steel
Installation temperature	20 ±5 °C
Operating temperature range	0 °C to 80 °C
Accuracy (at 20 °C)	±5 µm/m, calibration traceable to International Standards
Coefficient of thermal expansion (at 20 °C)	10.1 ±0.2 µm/m/°C
Maximum length	50 nm resolution readhead 13.42 m 1 nm resolution readhead 17.18 m
Mass	12.2 g/m

FASTRACK carrier

Form (height × width)	0.4 mm × 18 mm (includes adhesive)
Mounting	Self-adhesive backing tape
Material	Hardened and tempered martensitic stainless steel
Installation temperature	20 ±5 °C
Operating temperature range	0 °C to 80 °C
Coefficient of thermal expansion (at 20 °C)	10.1 ±0.2 µm/m/°C
Maximum supplied length	25 m
Minimum recommended length	100 mm
Mass	172 g/m

RTLA30/FASTRACK scale system installation drawing

Dimensions and tolerances in mm ¹

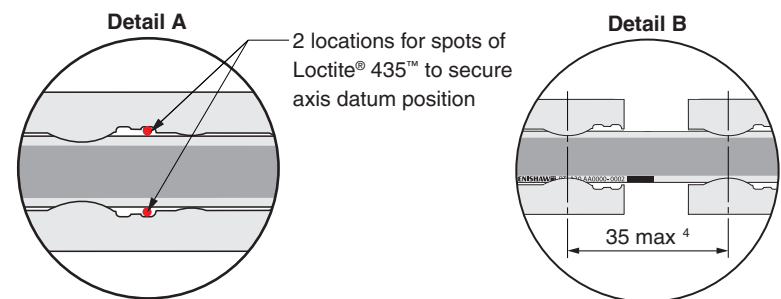
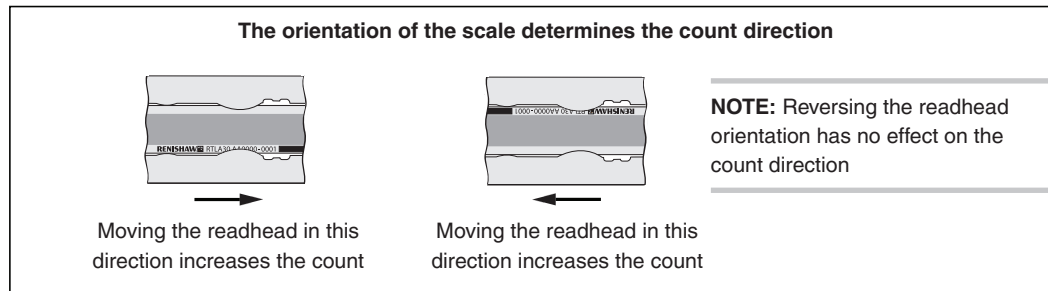
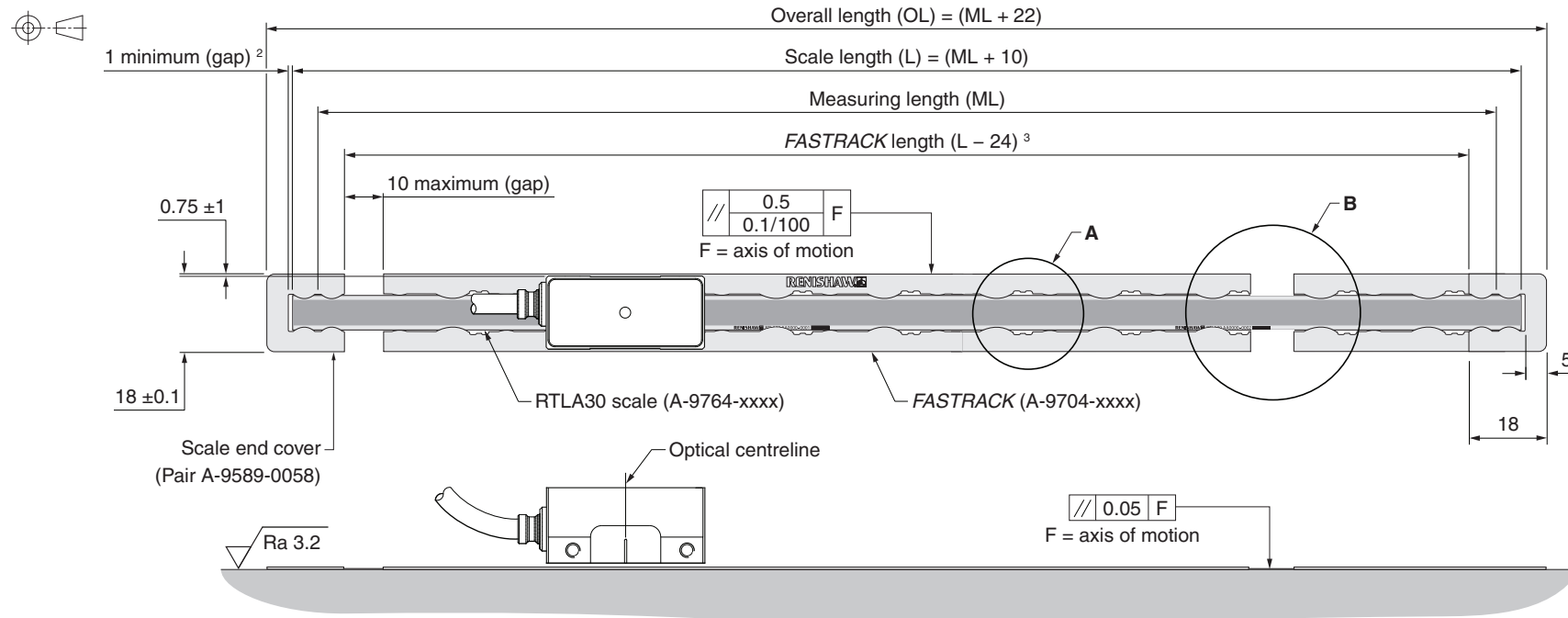

- ¹ All dimensions applicable when using side cable outlet version.
- ² For thermal expansion.
- ³ Assumes 1 mm gap between the scale and the end covers and zero gap between the FASTRACK carrier and the end covers. The minimum recommended FASTRACK carrier length = 100 mm.
- ⁴ Only required for sectional installations.

Equipment required for installing the RTLA30 and *FASTRACK* scale system

Required parts:

- Appropriate length of RTLA30 scale (see '[RTLA30/FASTRACK scale system installation drawing](#)' on page 61)
- Appropriate length of *FASTRACK* carrier (see '[RTLA30/FASTRACK scale system installation drawing](#)' on page 61)
- Loctite® 435™ (P-AD03-0012) ¹
- Appropriate cleaning solvents (see '[Storage and handling](#)' on page 19)
- Centre section removal tool (A-9589-0122)
- Small pair of pliers
- Dial test indicator (DTi)
- Protective gloves

Optional parts:

- Scale end cover (A-9589-0058)
- Renishaw scale wipes (A-9523-4040)
- Lint-free cloth
- Loctite® 435™ dispensing tip (P-TL50-0209)
- RTL scale installation tool (A-9589-0420)
- Guillotine (A-9589-0071) or shears (A-9589-0133) or cutting RTLA30 scale and *FASTRACK* carrier to length required

¹ Used to secure axis datum position. Alternative mechanical datum clamp is also available. Contact your local Renishaw representative for further details.

Cutting the RTLA30 scale and *FASTRACK* carrier

CAUTION: During handling or installation of *FASTRACK*, suitable gloves should be worn to protect against injury from sharp edges.

If required cut the *FASTRACK* carrier and RTLA30 scale to length (separately) using the guillotine or the shears after referring to the installation drawing. Refer to the '[RTLA30/*FASTRACK* scale system installation drawing](#)' on page 61.

Using the guillotine

The guillotine should be held securely in place, using a suitable vice or clamping method.

Once secured, feed the *FASTRACK* or the scale through the guillotine as shown, and place the guillotine press block down onto the *FASTRACK*/scale.

NOTE: Ensure the block is in the correct orientation (as shown below).

Whilst holding the block in place, in a smooth motion, pull down the lever to cut through the *FASTRACK*/scale.

Guillotine press block orientation when cutting the *FASTRACK* carrier

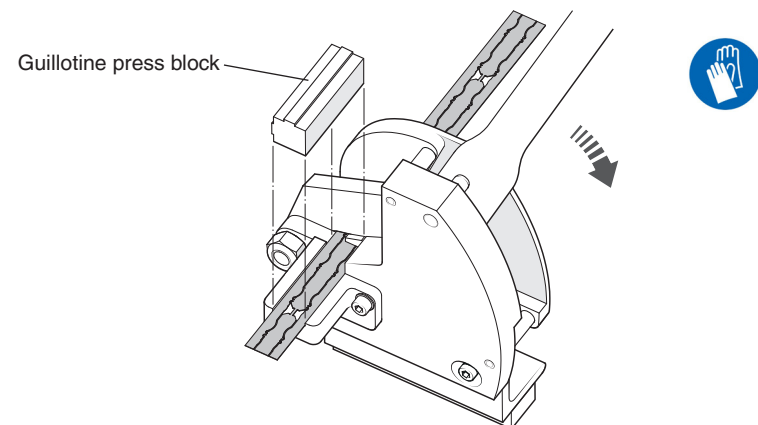

Guillotine press block orientation when cutting the RTLA30 scale

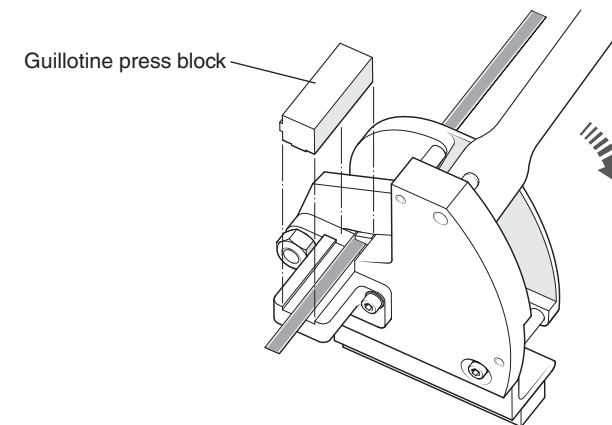

CAUTION: Do not cut
FASTRACK in these areas

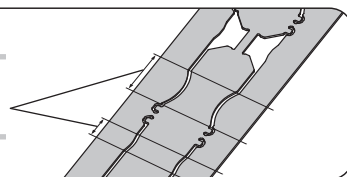

Using the shears

Feed the *FASTRACK* carrier or RTLA30 scale through the appropriately sized aperture on the shears (as shown below).

Hold the scale in place and close the shears in a smooth motion to cut through the scale.

Insertion of the *FASTRACK* carrier through widest aperture

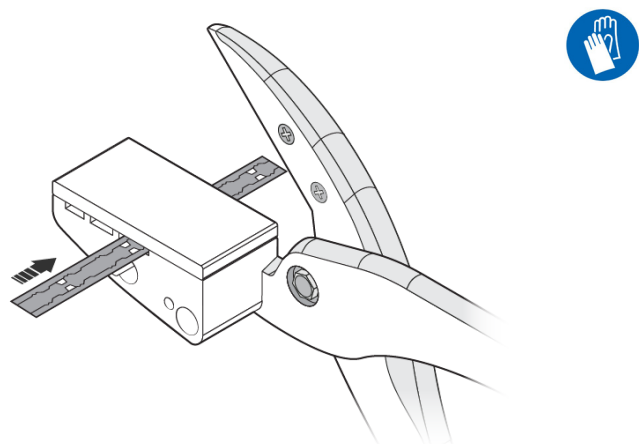

Insertion of the RTLA30 scale through the middle aperture

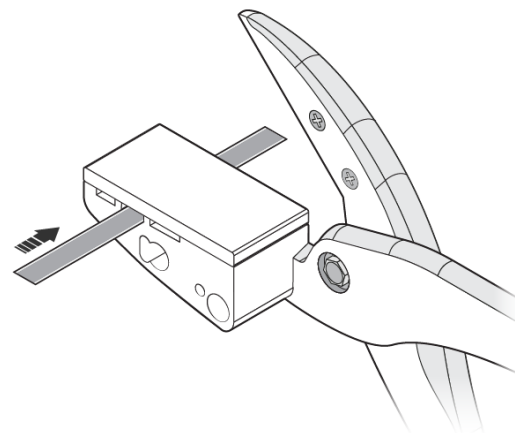

CAUTION: Do not cut
FASTRACK in these areas

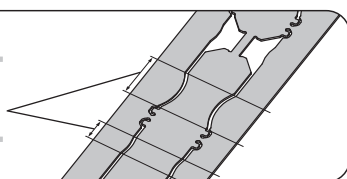

Applying the RTLA30 and *FASTRACK* scale system

1. Thoroughly clean and degrease the substrate and allow to dry.

For *FASTRACK* location a ledge, separate straight edge(s) or dowels can be used.

2. Check alignment of the ledge/separate straight edge(s) with respect to axis of motion (see '[RTLA30/FASTRACK scale system installation drawing](#)' on page 61).

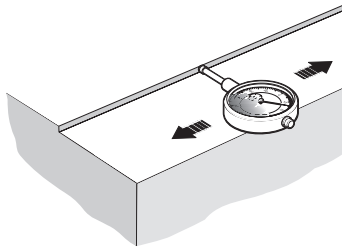

3. Before sticking the *FASTRACK* to the substrate bend the centre section upwards slightly using a small pair of pliers.

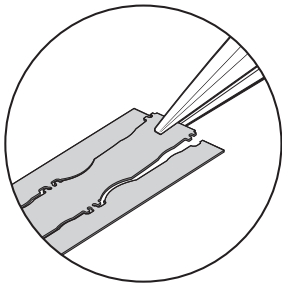

4. Remove the backing liner and stick the *FASTRACK* to the substrate locating it against the ledge/separate straight edge(s) or dowels.

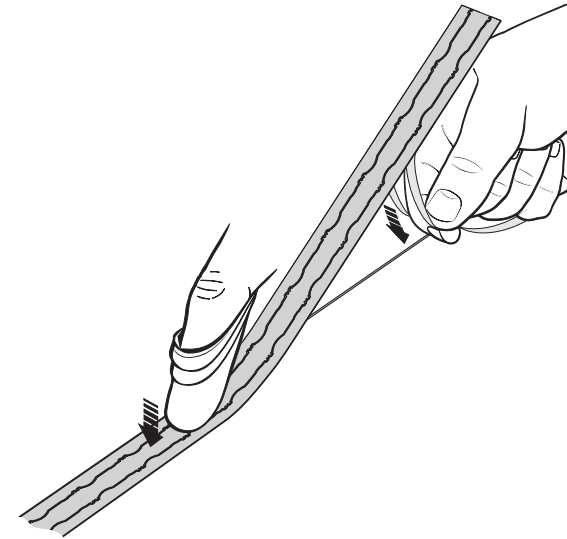

Ensure complete adhesion to the substrate by applying firm finger pressure along the length of the *FASTRACK* from the centre outwards towards each end using a lint-free cloth.

NOTE: Allow the *FASTRACK* a minimum of 20 minutes to adhere before removing the centre section.

- Engage the centre section removal tool and, with consistent forward pressure, remove the centre section of the *FASTRACK* carrier.

If the ledge method or similar is used then the appropriate side panel on the removal tool will need to be removed as shown below.

IMPORTANT: Wear suitable protective gloves whilst carrying out this procedure to avoid risk of cuts.

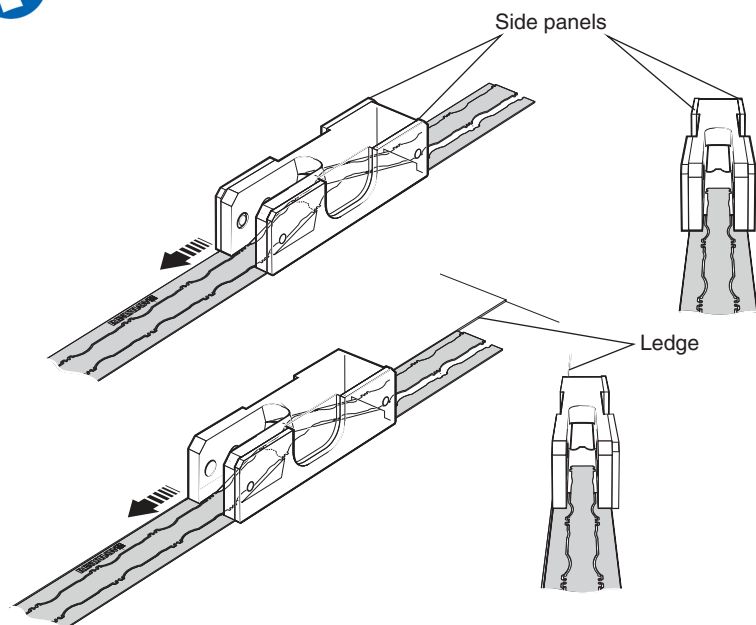

- Slide the RTLA30 scale into the *FASTRACK* ensuring the scale is fed under the projections as shown below.

The RTLA30 scale can be installed manually by either pulling or pushing it through the *FASTRACK* carrier.

Alternatively, use the optional RTL scale installation tool as shown below.

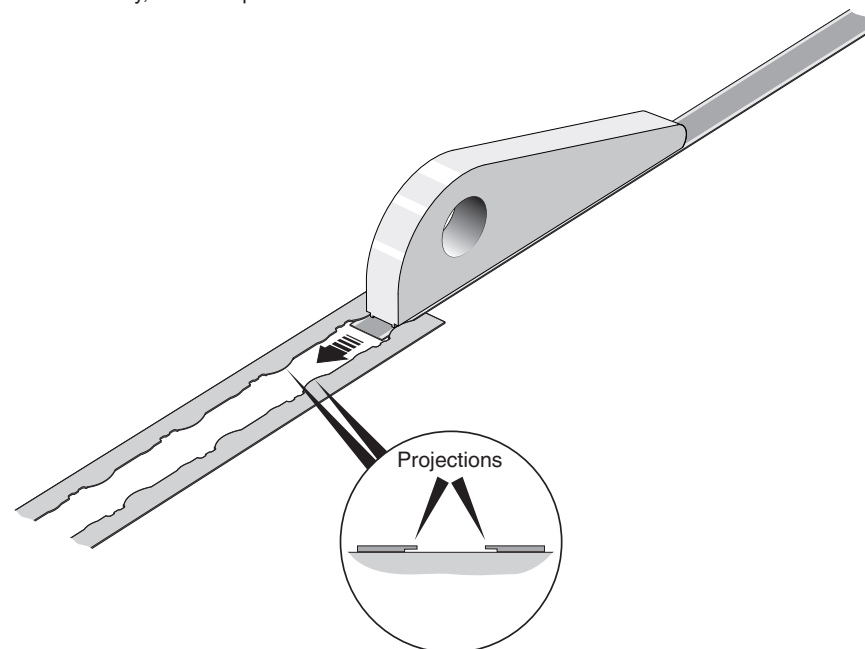

NOTE: For instructions on how to use the scale installation tool, download the *RTL* scale installation tool* user guide (Renishaw part no. M-9589-9101) from the website at www.renishaw.com/resolutedownloads.

IMPORTANT: If manually installing the scale using fingers, suitable gloves should be worn to protect against injury from sharp edges.



7. Create a scale datum. Using dispensing tip apply Loctite 435 between scale and *FASTRACK* so it wicks underneath the scale and *FASTRACK* adjacent to the user selected datum location as shown below.

NOTE: Only apply Loctite 435 in the locations shown below. Loctite 435 has been carefully selected as it will wick under the scale to lock it to the substrate. Dispensing tips are available.

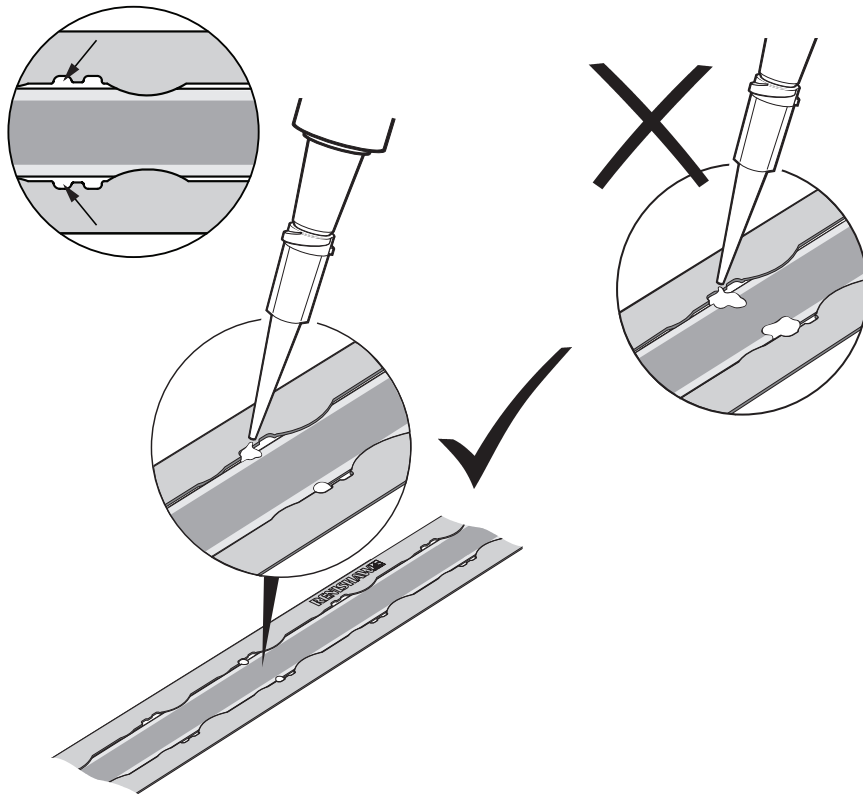

NOTE: Mechanical datum clamp also available. Contact your local Renishaw representative for more details.

8. Fix the self-adhesive end covers ensuring a gap of at least 1 mm.

NOTE: End covers must be fitted to ensure that the encoder system adheres to Functional Safety guidelines.

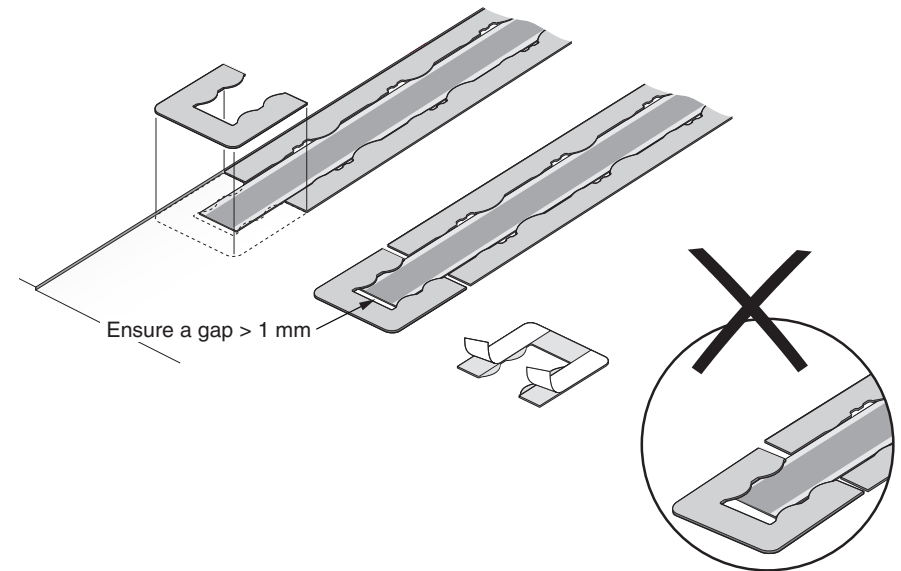

9. Clean the *FASTRACK* and the scale using a lint-free cloth.

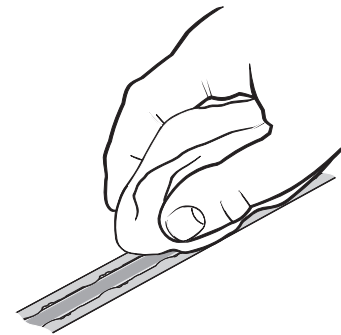

RESOLUTE readhead mounting and alignment

Mounting brackets

The bracket must have a flat mounting surface and should provide adjustment to enable conformance to the installation tolerances, allow adjustment to the rideheight of the readhead, and be sufficiently stiff to prevent deflection or vibration of the readhead during operation.

For the RESOLUTE Functional Safety readhead mounting:

- The recommended screw type is M3 × 0.5 mm and must comply with: ISO 4762 M3.
- The recommended thread engagement is 6 mm.
- The maximum screw clearance hole diameter is 4 mm.
- Recommended tightening torque 0.9 Nm to 1.1 Nm.
- The use of a thread locking compound is recommended.
- The readhead to interface cable must be secured to a part that does not move relative to the readhead using a suitable clip within 50 mm of exiting the readhead with a minimum bend radius > 10 mm.
- Cable rolling radius must be > 25 mm when the cable is routed through moving trunking/a cable chain.
- Route the cable away from operating environments that will exceed the EMC limits defined IEC61800-5-2: Annex E second environment– Electromagnetic immunity requirement for safety related systems.

Readhead set-up

Ensure that the scale, readhead optical window and mounting face are clean and free from obstructions.

NOTE: When cleaning the readhead and scale apply cleaning fluid sparingly, do not soak.

To set nominal rideheight, place the readhead spacer with the 'L' shaped aperture under the optical centre of the readhead to allow normal LED function during set-up procedure. Adjust the readhead to maximize the signal strength around the full axis rotation or full length of axis to achieve a green or blue LED.

NOTES:

- Flashing of set-up LED indicates scale reading error. The flashing state is latched; remove power to reset.
- The optional Advanced Diagnostic Tool ADTa-100¹ (A-6525-0100) and ADT View software² can be used to aid installation. The ADTa-100 and ADT View software are only compatible with RESOLUTE readheads showing the **ADT** mark. Contact your local Renishaw representative for other readhead compatibility.
- RESOLUTE readhead shown with REXA ring

¹ For more details refer to the Advanced Diagnostic Tools and ADT View software User guide (Renishaw part no. M-6195-9413).

² The software can be downloaded for free from www.renishaw.com/adt.

³ For RTLA30/FASTRACK systems use the 0.6 mm red spacer

⁴ 0.6 ±0.12 mm for the RTLA30/FASTRACK system

⁵ The LED is activated regardless of whether the corresponding messages have been reconfigured.

⁶ The colour depends upon the LED status when component recognition is activated via p0144=1.

RESOLUTE readhead and DRIVE-CLiQ interface status LEDs

Signal %	> 95	> 70 to 95	> 50 to 70	≤ 50
Colour	Blue	Green	Orange	Red

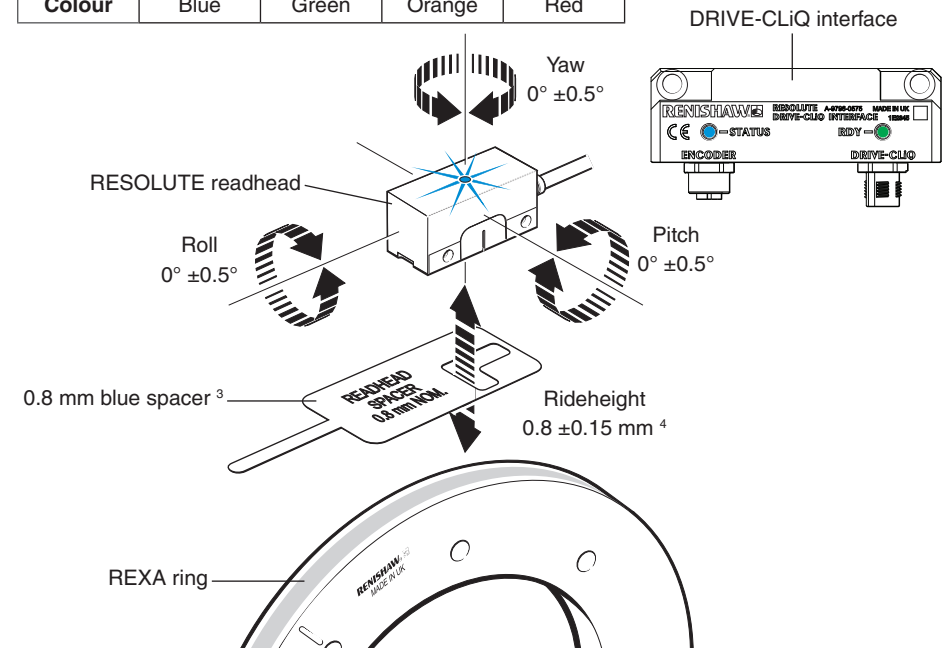

DRIVE-CLiQ interface RDY LED functions

Colour	Status	Description
-	Off	Power supply is missing or outside of permissible tolerance range
Green	Continuous light	The component is ready for operation and cyclic DRIVE-CLiQ communication is taking place
Orange	Continuous light	DRIVE-CLiQ communication is being established
Red	Continuous light	At least one fault is present in this component ⁵
Green/orange or red/orange	Flashing light	Component recognition via LED is activated (p0144) ⁶

System configuration

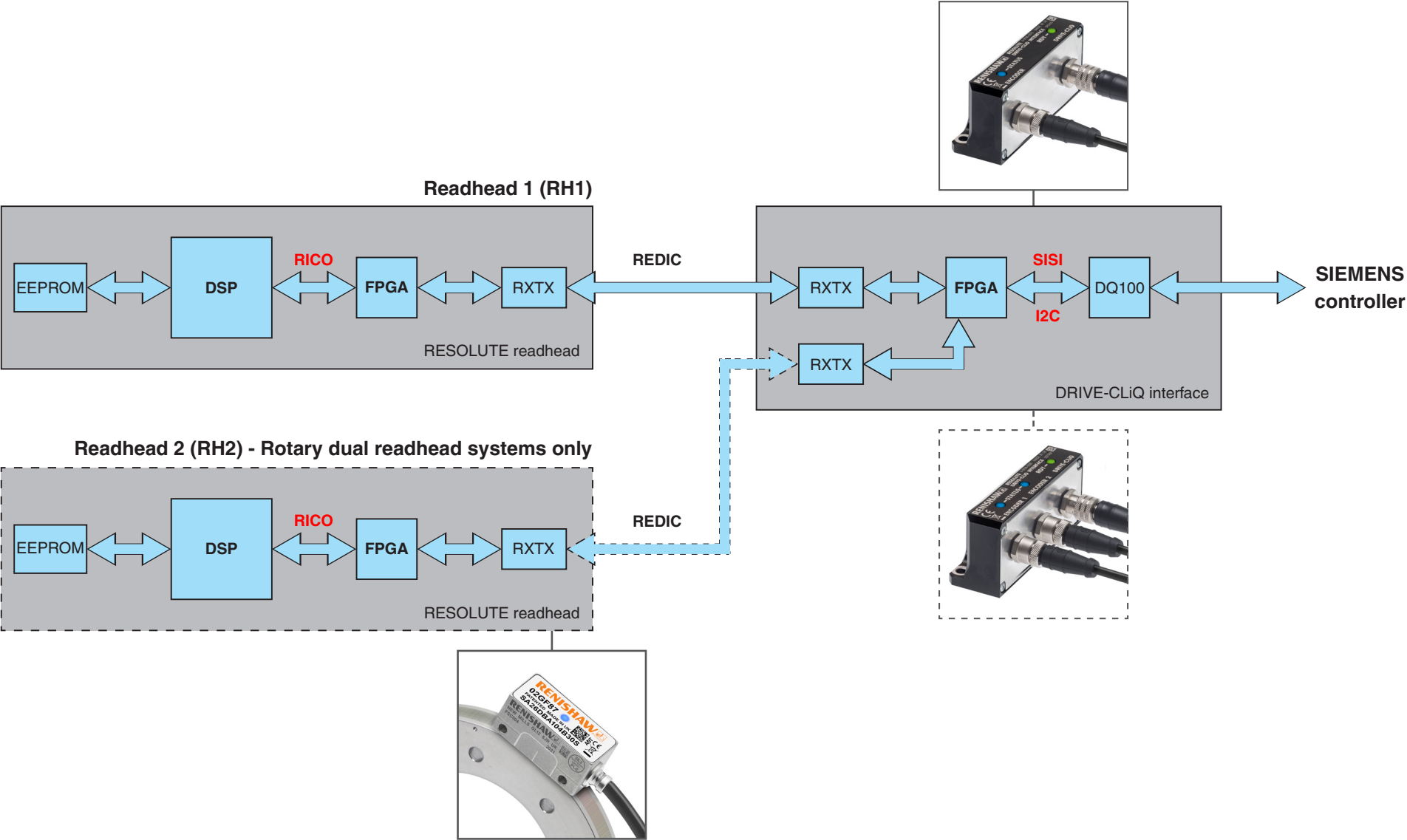

Electrical connections

RESOLUTE grounding and shielding

Single readhead system

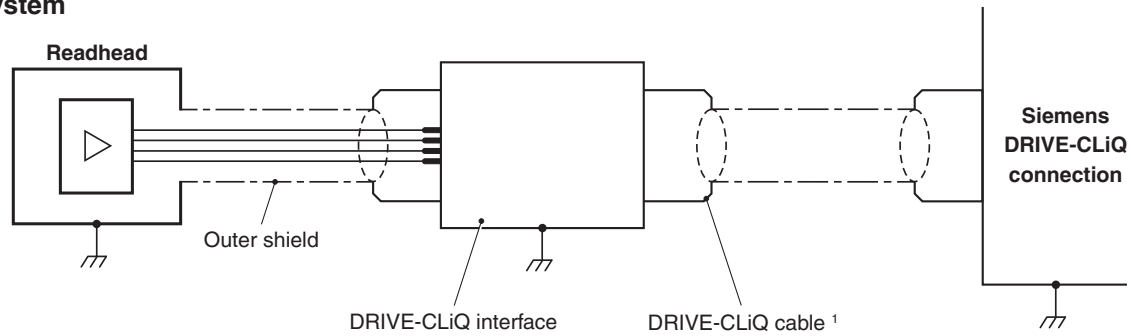

Dual readhead system

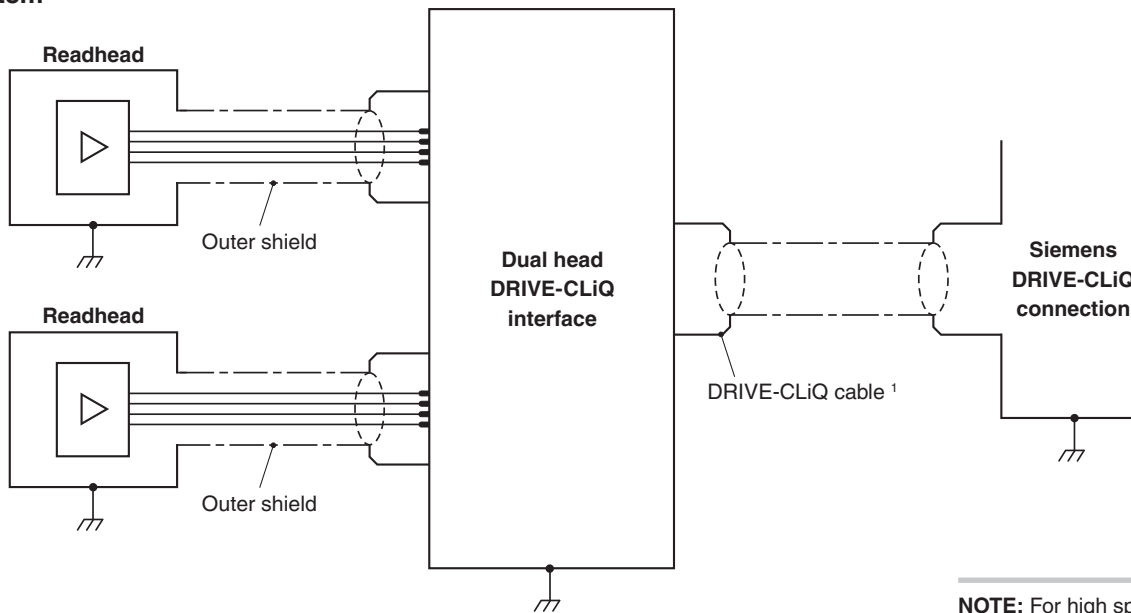

NOTE: For high speed applications, it is recommended to use similar cable lengths for each readhead to ensure the readings are simultaneous and achieve the highest accuracy.

¹ The DRIVE-CLiQ cable is a proprietary part and is not supplied by Renishaw plc.

RESOLUTE Functional Safety Siemens DRIVE-CLiQ Serial interface

Power supply	Voltage and current	4.3 W maximum 24 V power is provided by the DRIVE-CLiQ network
	Interface over voltage protection	-36 V to +36 V
Temperature	Storage (system)	-20 °C to +70 °C
	Installation (system)	20 ±5 °C
	Operating (readhead)	0 °C to +80 °C
	Operating (interface)	0 °C to +55 °C
Humidity	(system)	95% relative humidity (non-condensing) to IEC 60068-2-78
Sealing	(readhead)	IP64
	(interface)	IP67 ¹
Environment protection		Protection class III Pollution degree II Altitude 2000 m
Acceleration	Operating (readhead)	500 m/s ² , 3 axes
Shock	Non-operating (readhead and interface)	500 m/s ² , 11 ms, ½ sine, 3 axes
Maximum acceleration of scale with respect to readhead ²		2000 m/s ²
Vibration	Operating (readhead)	Sinusoidal 300 m/s ² max @ 55 Hz to 2000 Hz, 3 axes
	Operating (interface)	Sinusoidal 100 m/s ² max @ 55 Hz to 2000 Hz, 3 axes
Mass	(readhead)	18 g
	(readhead cable)	32 g/m
	(interface)	218 g
Readhead cable		7 core, tinned and annealed copper, 28 AWG Single-shielded, outside diameter 4.7 ±0.2 mm Flex life > 40 × 10 ⁶ cycles at 20 mm bend radius 10 m maximum length (refer to Siemens DRIVE-CLiQ specifications for maximum cable length from interface to controller) UL recognised component 

CAUTION: The RESOLUTE encoder system has been designed to meet the requirements of IEC 61800-5-2: Annex E second environment, but must be correctly integrated to achieve EMC compliance. In particular, attention to shielding arrangements is essential.

¹ If the original termination is altered by the user or an extension cable is used, it is the responsibility of the system manufacturer to ensure the IP rating of the interface connection meets their requirements.

² This is the worst-case figure that is correct for the slowest communications request rates. For faster request rates, the maximum acceleration of scale with respect to the readhead can be higher. For more details, contact your local Renishaw representative.

RESOLUTE output signals

Readhead output

Function	Signal	Wire colour	Pin	
			M12 (S)	13-way JST (F)
Power	5 V	Brown	2	9
	0 V	White Green	5, 8	5, 7
Serial communications	A+	Violet	3	11
	A-	Yellow	4	13
Shield	-	Shield	Case	External
Reserved	Do not connect	Grey	7	1
		Pink	6	3

DRIVE-CLiQ interface output

Function	Signal	Pin
		M12 ('A' code)
Power	24V	1
	0V	5
DRIVE-CLiQ communications	RX+	3
	RX-	4
	TX+	7
	TX-	6
Shield	-	Case

M12 (sealed) connector (Termination code S)

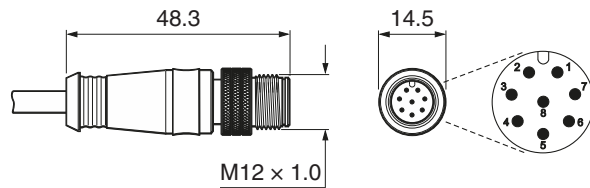

13-way flying lead (Termination code F)

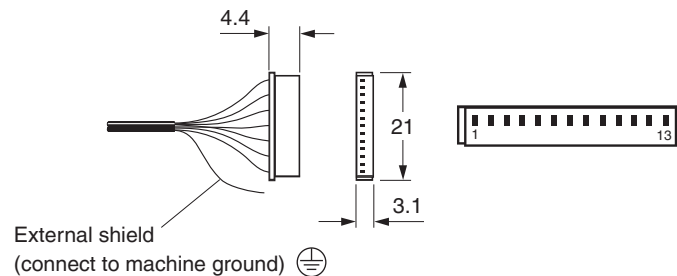

Siemens DRIVE-CLiQ interface drawing – single readhead input

Dimensions and tolerances in mm

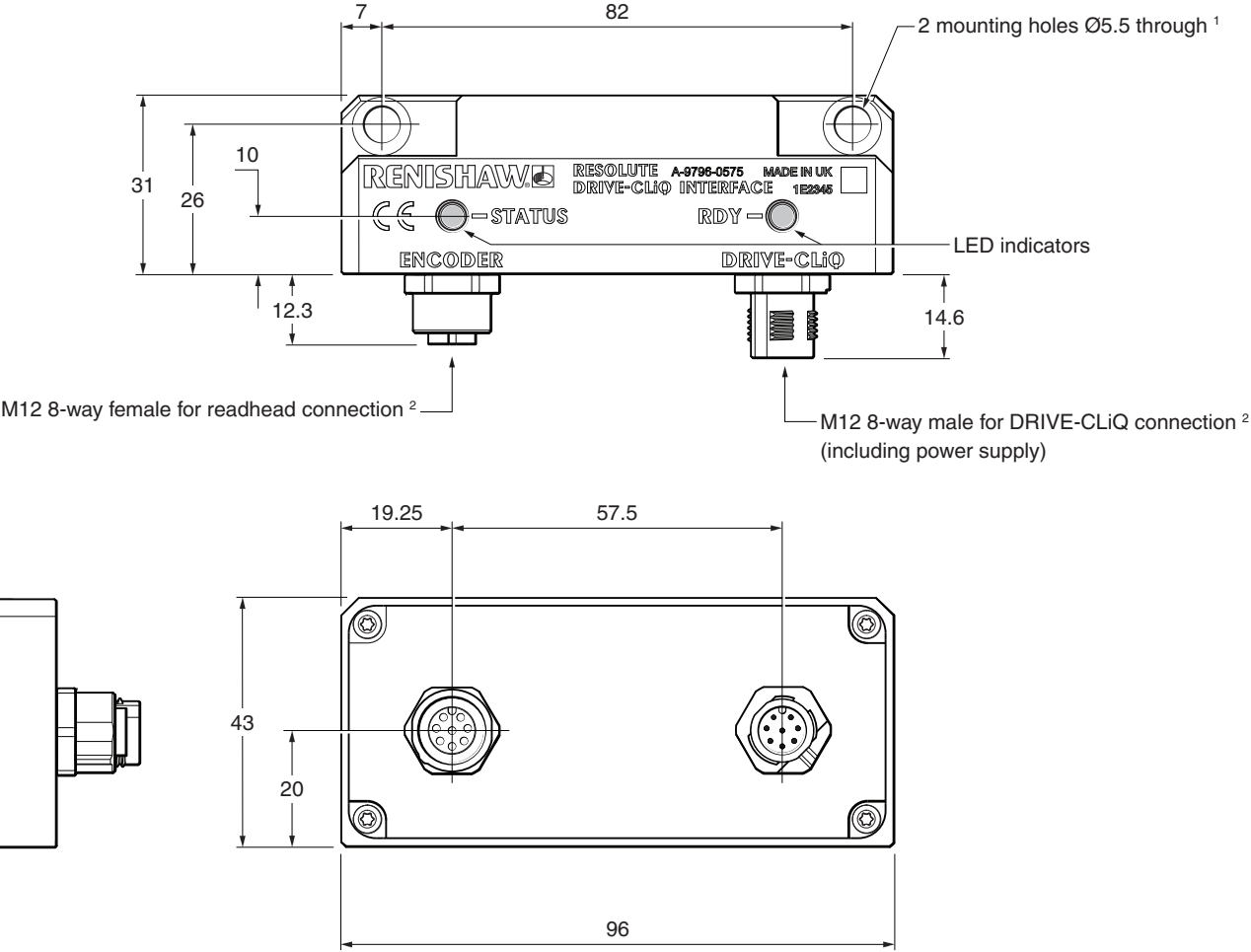

¹ ISO 4762-M5. The recommended thread engagement is ≥ 5 mm. The recommended tightening torque is 4 Nm.

² Maximum tightening torque 4 Nm.

Siemens DRIVE-CLiQ interface drawing – dual readhead input

Dimensions and tolerances in mm

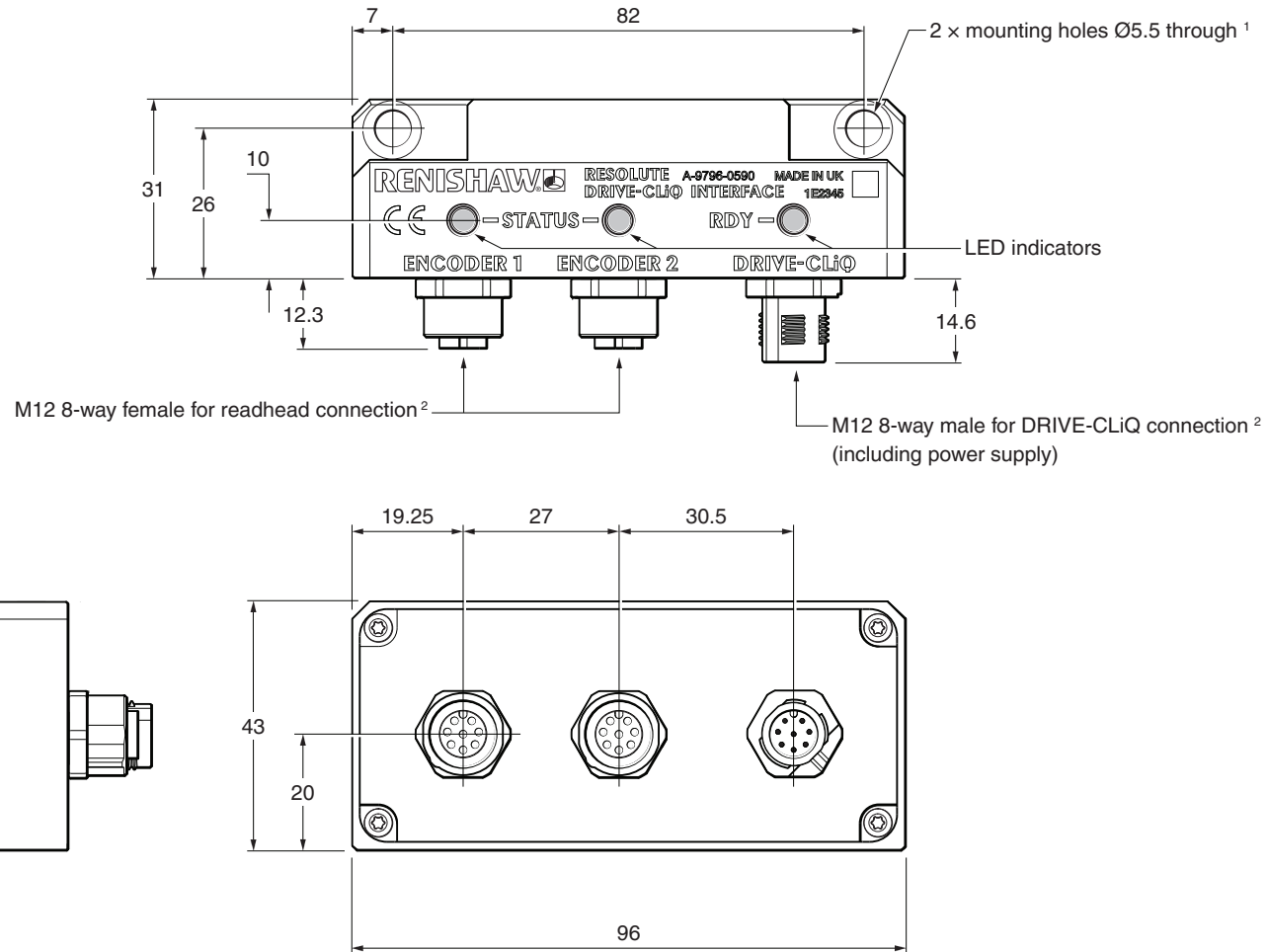



¹ ISO 4762-M5. The recommended thread engagement is ≥ 5 mm. The recommended tightening torque is 4 Nm.

² Maximum tightening torque 4 Nm.

www.renishaw.com/contact

 #renishaw

 +44 (0) 1453 524524  uk@renishaw.com

© 2019–2025 Renishaw plc. All rights reserved. This document may not be copied or reproduced in whole or in part, or transferred to any other media or language by any means, without the prior written permission of Renishaw.
RENISHAW® and the probe symbol are registered trade marks of Renishaw plc. Renishaw product names, designations and the mark 'apply innovation' are trade marks of Renishaw plc or its subsidiaries. DRIVE-CLIQ is a registered trademark of Siemens.
Other brand, product or company names are trade marks of their respective owners.
Renishaw plc. Registered in England and Wales. Company no: 1106260. Registered office: New Mills, Wotton-under-Edge, Glos, GL12 8JR, UK.

WHILE CONSIDERABLE EFFORT WAS MADE TO VERIFY THE ACCURACY OF THIS DOCUMENT AT PUBLICATION, ALL WARRANTIES, CONDITIONS, REPRESENTATIONS AND LIABILITY, HOWSOEVER ARISING, ARE EXCLUDED TO THE EXTENT PERMITTED BY LAW. RENISHAW RESERVES THE RIGHT TO MAKE CHANGES TO THIS DOCUMENT AND TO THE EQUIPMENT, AND/OR SOFTWARE AND THE SPECIFICATION DESCRIBED HEREIN WITHOUT OBLIGATION TO PROVIDE NOTICE OF SUCH CHANGES.

Part no.: M-9796-9134-03-B
Issued: 03.2025