

ATOM DX™ and RKLf linear encoder system

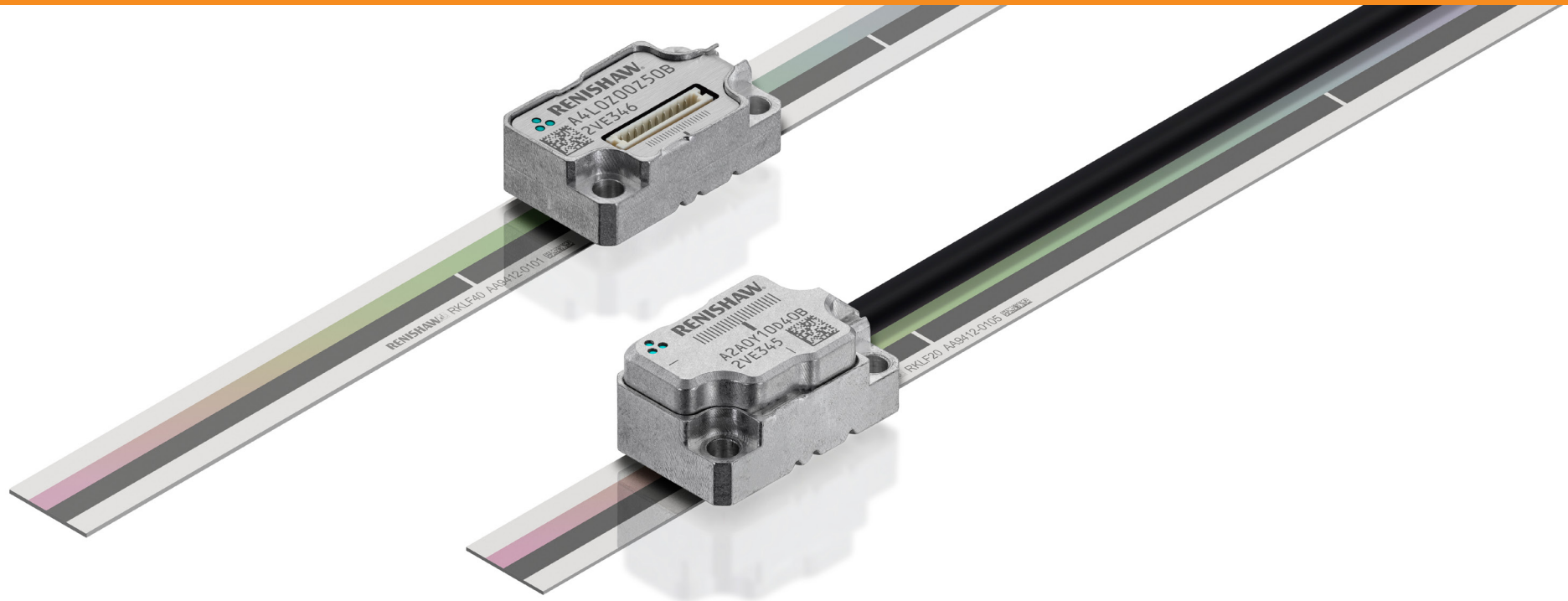

This page is intentionally left blank.

Contents

Legal notices5
Storage and handling10
ATOM DX system installation overview12
RKLF tape scale installation drawing13
RKLF application methods14
Equipment required for mounting the RKLF with a scale applicator.15
RKLF scale application.16
Fitting the end clamps18
RKLF reference mark deselection19
System connection: Top exit readhead20
Readhead mounting and alignment: Methods22
ATOM DX calibration overview28
System calibration29
Restoring factory defaults.30
Switching Automatic Gain Control (AGC) on or off.30
Readhead LED diagnostics31
Troubleshooting32
ATOM DX cabled readhead dimensions.35
ATOM DX top exit readhead dimensions36
Bracket dimensions37
Output signals.38
Speed39

Electrical connections41
Output specifications43
General specifications44
RKLF scale specifications45

Legal notices

Patents

Features of Renishaw's ATOM DX™ encoder systems and similar products are the subjects of one or more of the following patents and patent applications:

EP1946048	JP5017275	US7624513	EP1957943	US7839296
CN105008865	EP3564628	EP2936073	IN428552	JP6563813
KR2128135	US9952068	US10768026	CN106104216	EP3052898
IN429478	JP7153997	US10281301	CN105814408	EP3052897
IN455785	JP7032045	US10823587	CN106030251	EP3052895
JP6811610	EP3052900	IN399411	JP7083228	US11543270
US8466943				

Terms and conditions and warranty

Unless you and Renishaw have agreed and signed a separate written agreement, the equipment and/or software are sold subject to the Renishaw Standard Terms and Conditions supplied with such equipment and/or software, or available on request from your local Renishaw office.

Renishaw warrants its equipment and software for a limited period (as set out in the Standard Terms and Conditions), provided that they are installed and used exactly as defined in associated Renishaw documentation. You should consult these Standard Terms and Conditions to find out the full details of your warranty.

Equipment and/or software purchased by you from a third-party supplier is subject to separate terms and conditions supplied with such equipment and/or software. You should contact your third-party supplier for details.

Declaration of Conformity

Renishaw plc hereby declares that the ATOM DX encoder system is in compliance with the essential requirements and other relevant provisions of:

- the applicable EU directives
- the relevant statutory instruments under UK law



The full text of the declaration of conformity is available at www.renishaw.com/productcompliance.

Compliance

Federal Code Of Regulation (CFR) FCC Part 15 – RADIO FREQUENCY DEVICES

47 CFR Section 15.19

This device complies with part 15 of the FCC Rules. Operation is subject to the following two conditions: (1) This device may not cause harmful interference, and (2) this device must accept any interference received, including interference that may cause undesired operation.

47 CFR Section 15.21

The user is cautioned that any changes or modifications not expressly approved by Renishaw plc or authorised representative could void the user's authority to operate the equipment.

47 CFR Section 15.105

This equipment has been tested and found to comply with the limits for a Class A digital device, pursuant to part 15 of the FCC Rules. These limits are designed to provide reasonable protection against harmful interference when the equipment is operated in a commercial environment.

This equipment generates, uses, and can radiate radio frequency energy and, if not installed and used in accordance with the instruction manual, may cause harmful interference to radio communications. Operation of this equipment in a residential area is likely to cause harmful interference in which case the user will be required to correct the interference at his own expense.

47 CFR Section 15.27

This unit was tested with shielded cables on the peripheral devices. Shielded cables must be used with the unit to ensure compliance.

Supplier's Declaration of Conformity

47 CFR § 2.1077 Compliance Information

Unique Identifier: ATOM DX

Responsible Party - U.S. Contact Information

Renishaw Inc.
1001 Wesemann Drive
West Dundee
Illinois
IL 60118
United States
Telephone number: +1 847 286 9953
Email: usa@renishaw.com

ICES-003 – Information Technology Equipment (including Digital Apparatus)

This ISM device complies with Canadian ICES-003(A).

Cet appareil ISM est conforme à la norme ICES-003(A).

Intended use

The ATOM DX encoder system is designed to measure position and provide that information to a drive or controller in applications requiring motion control. It must be installed, operated, and maintained as specified in Renishaw documentation and in accordance with the Standard Terms and Conditions of the Warranty and all other relevant legal requirements.

Further information

Further information relating to the ATOM DX encoder range can be found in the *ATOM DX™ miniature encoder system* data sheet (Renishaw part no. L-9517-9736), *Advanced Diagnostic Tool ADTi-100* data sheet (Renishaw part no. L-9517-9699), *Advanced Diagnostic Tool ADTi-100 and ADT View software* quick-start guide (Renishaw part no. M-6195-9321), and the *Advanced Diagnostic Tool ADTi-100 and ADT View software* user guide (Renishaw part no. M-6195-9413). These can be downloaded from our website at www.renishaw.com/atomdxdownloads and are also available from your local representative.

Packaging

The packaging of our products contains the following materials and can be recycled.

Packing component	Material	ISO 11469	Recycling guidance
Outer box	Cardboard	Not applicable	Recyclable
	Polypropylene	PP	Recyclable
Inserts	Low density polyethylene foam	LDPE	Recyclable
	Cardboard	Not applicable	Recyclable
Bags	High density polyethylene bag	HDPE	Recyclable
	Metallised polyethylene	PE	Recyclable

REACH regulation

Information required by Article 33(1) of Regulation (EC) No. 1907/2006 ("REACH") relating to products containing substances of very high concern (SVHCs) is available at www.renishaw.com/REACH.

Disposal of waste electrical and electronic equipment



The use of this symbol on Renishaw products and/or accompanying documentation indicates that the product should not be mixed with general household waste upon disposal. It is the responsibility of the end user to dispose of this product at a designated collection point for waste electrical and electronic equipment (WEEE) to enable reuse or recycling. Correct disposal of this product will help to save valuable resources and prevent potential negative effects on the environment. For more information, contact your local waste disposal service or Renishaw distributor.

ATOM DX software notices

Third party licences

The ATOM DX product includes embedded software (firmware) to which the following notices apply:

Copyright © 2009 - 2013 ARM LIMITED

All rights reserved.

This Redistribution and use in source and binary forms, with or without modification, are permitted provided that the following conditions are met:

- Redistributions of source code must retain the above copyright notice, this list of conditions and the following disclaimer.
- Redistributions in binary form must reproduce the above copyright notice, this list of conditions and the following disclaimer in the documentation and/or other materials provided with the distribution.
- Neither the name of ARM nor the names of its contributors may be used to endorse or promote products derived from this software without specific prior written permission.

THIS SOFTWARE IS PROVIDED BY THE COPYRIGHT HOLDERS AND CONTRIBUTORS "AS IS" AND ANY EXPRESS OR IMPLIED WARRANTIES, INCLUDING, BUT NOT LIMITED TO, THE IMPLIED WARRANTIES OF MERCHANTABILITY AND FITNESS FOR A PARTICULAR PURPOSE ARE DISCLAIMED. IN NO EVENT SHALL COPYRIGHT HOLDERS AND CONTRIBUTORS BE LIABLE FOR ANY DIRECT, INDIRECT, INCIDENTAL, SPECIAL, EXEMPLARY, OR CONSEQUENTIAL DAMAGES (INCLUDING, BUT NOT LIMITED TO, PROCUREMENT OF SUBSTITUTE GOODS OR SERVICES; LOSS OF USE, DATA, OR PROFITS; OR BUSINESS INTERRUPTION) HOWEVER CAUSED AND ON ANY THEORY OF LIABILITY, WHETHER IN CONTRACT, STRICT LIABILITY, OR TORT (INCLUDING NEGLIGENCE OR OTHERWISE) ARISING IN ANY WAY OUT OF THE USE OF THIS SOFTWARE, EVEN IF ADVISED OF THE POSSIBILITY OF SUCH DAMAGE.

Copyright © NXP Semiconductors, 2012

All rights reserved.

Software that is described herein is for illustrative purposes only which provides customers with programming information regarding the LPC products.

This software is supplied "AS IS" without any warranties of any kind, and NXP Semiconductors and its licensor disclaim any and all warranties, express or implied, including all implied warranties of merchantability, fitness for a particular purpose and non-infringement of intellectual property rights.

- NXP Semiconductors assumes no responsibility or liability for the use of the software, conveys no license or rights under any patent, copyright, mask work right, or any other intellectual property rights in or to any products.
- NXP Semiconductors reserves the right to make changes in the software without notification.
- NXP Semiconductors also makes no representation or warranty that such application will be suitable for the specified use without further testing or modification.

Permission to use, copy, modify, and distribute this software and its documentation is hereby granted, under NXP Semiconductors' and its licensor's relevant copyrights in the software, without fee, provided that it is used in conjunction with NXP Semiconductors microcontrollers. This copyright, permission, and disclaimer notice must appear in all copies of this code.

US government notice

NOTICE TO UNITED STATES GOVERNMENT CONTRACT AND PRIME CONTRACT CUSTOMERS

This software is commercial computer software that has been developed by Renishaw exclusively at private expense. Notwithstanding any other lease or licence agreement that may pertain to, or accompany the delivery of, this computer software, the rights of the United States Government and/or its prime contractors regarding its use, reproduction and disclosure are as set forth in the terms of the contract or subcontract between Renishaw and the United States Government, civilian federal agency or prime contractor respectively. Please consult the applicable contract or subcontract and the software licence incorporated therein, if applicable, to determine your exact rights regarding use, reproduction and/or disclosure.

Renishaw End User Licence Agreement (EULA)

Renishaw software is licensed in accordance with the Renishaw licence at www.renishaw.com/legal/softwareterms.

Storage and handling

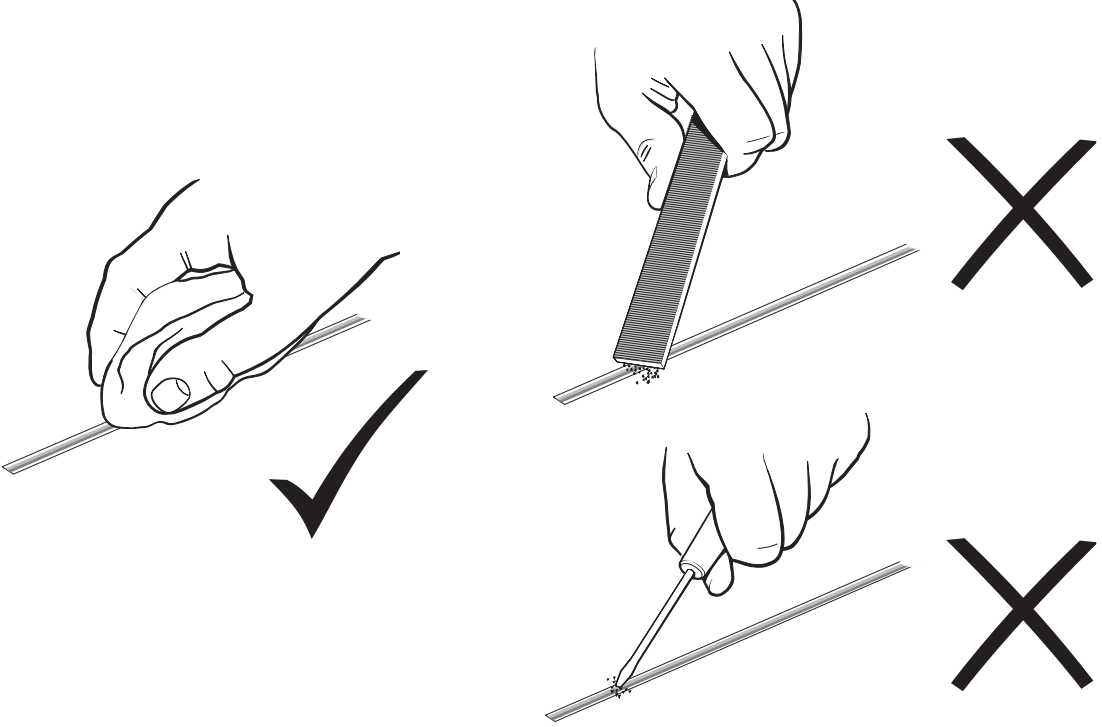

Minimum bend radius

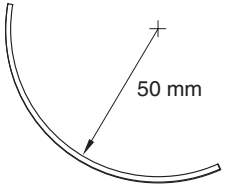

NOTE: During storage, ensure that the self-adhesive tape is on the outside of the bend.

System

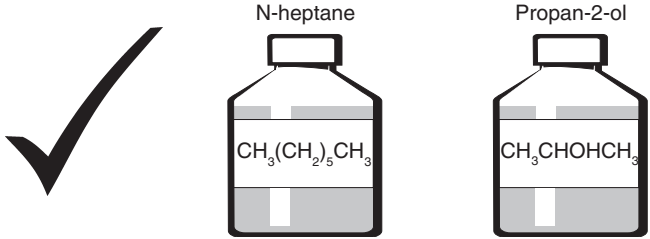

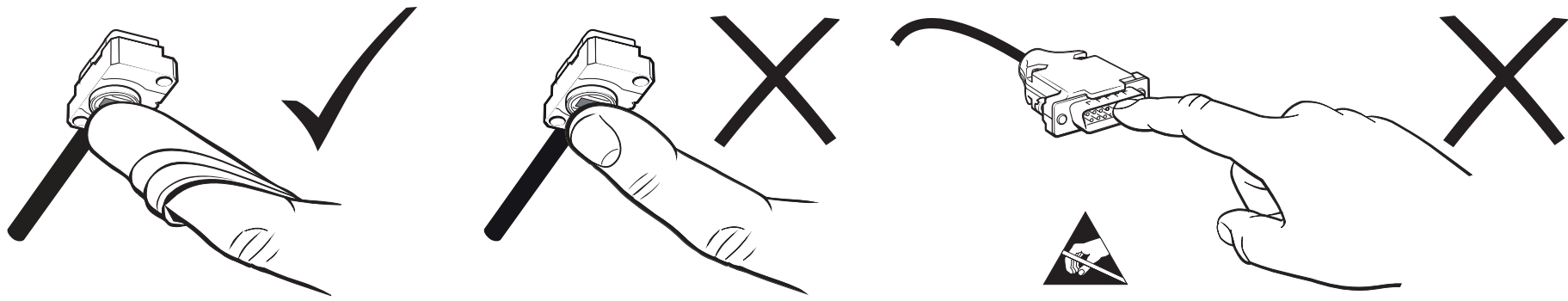

Temperature

Storage	
System	-20 °C to +70 °C

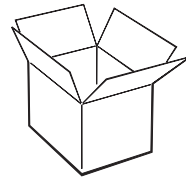

Operating	
System	0 °C to +70 °C

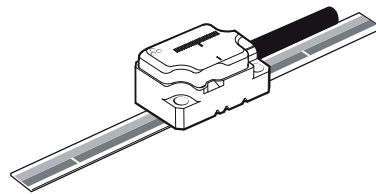

Humidity

95% relative humidity (non-condensing) to IEC 60068-2-78

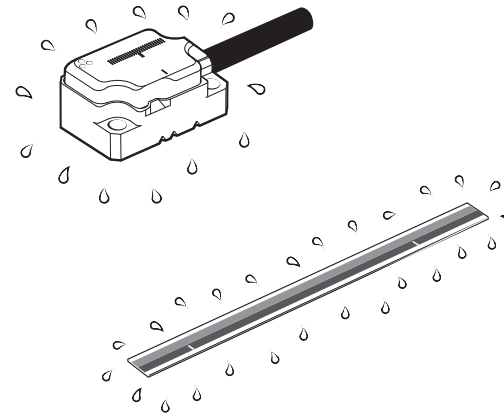

ATOM DX system installation overview

This section gives an overview of the steps involved in installing, setting-up and calibrating an ATOM DX encoder system. More detailed information is contained within the rest of the document.

For information on designing the readhead and scale into the system refer to the detailed installation drawings and 3D models at www.renishaw.com/atomdxdownloads or contact your local Renishaw representative. For information on the ATOM DX product range refer to the *ATOM DX™ miniature encoder system* data sheet (Renishaw part no. L-9517-9736).

IMPORTANT: Prior to installing the readhead and linear scale, the installation drawing should be reviewed to ensure correct orientation of the readhead relative to the scale (see page 13).

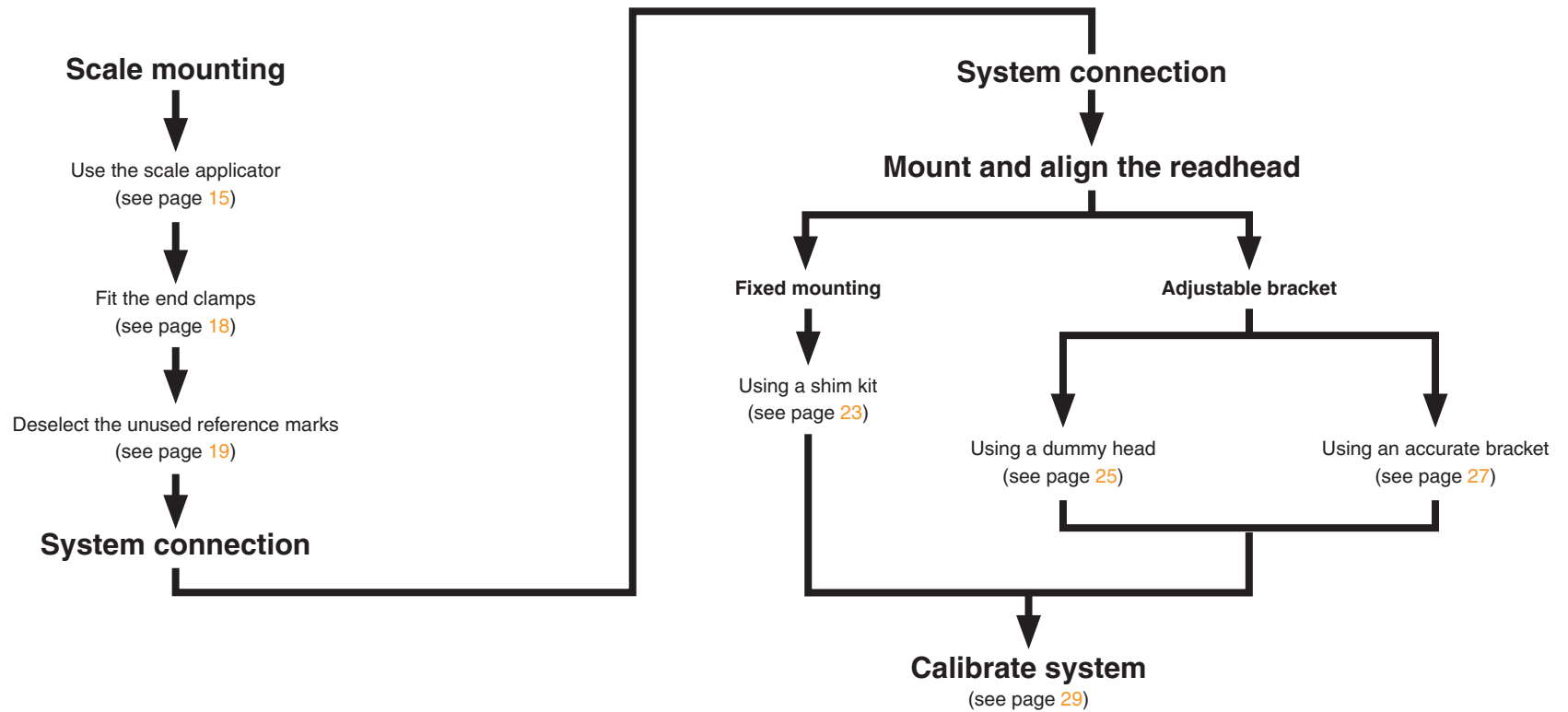

RKLF tape scale installation drawing

Dimensions and tolerances in mm

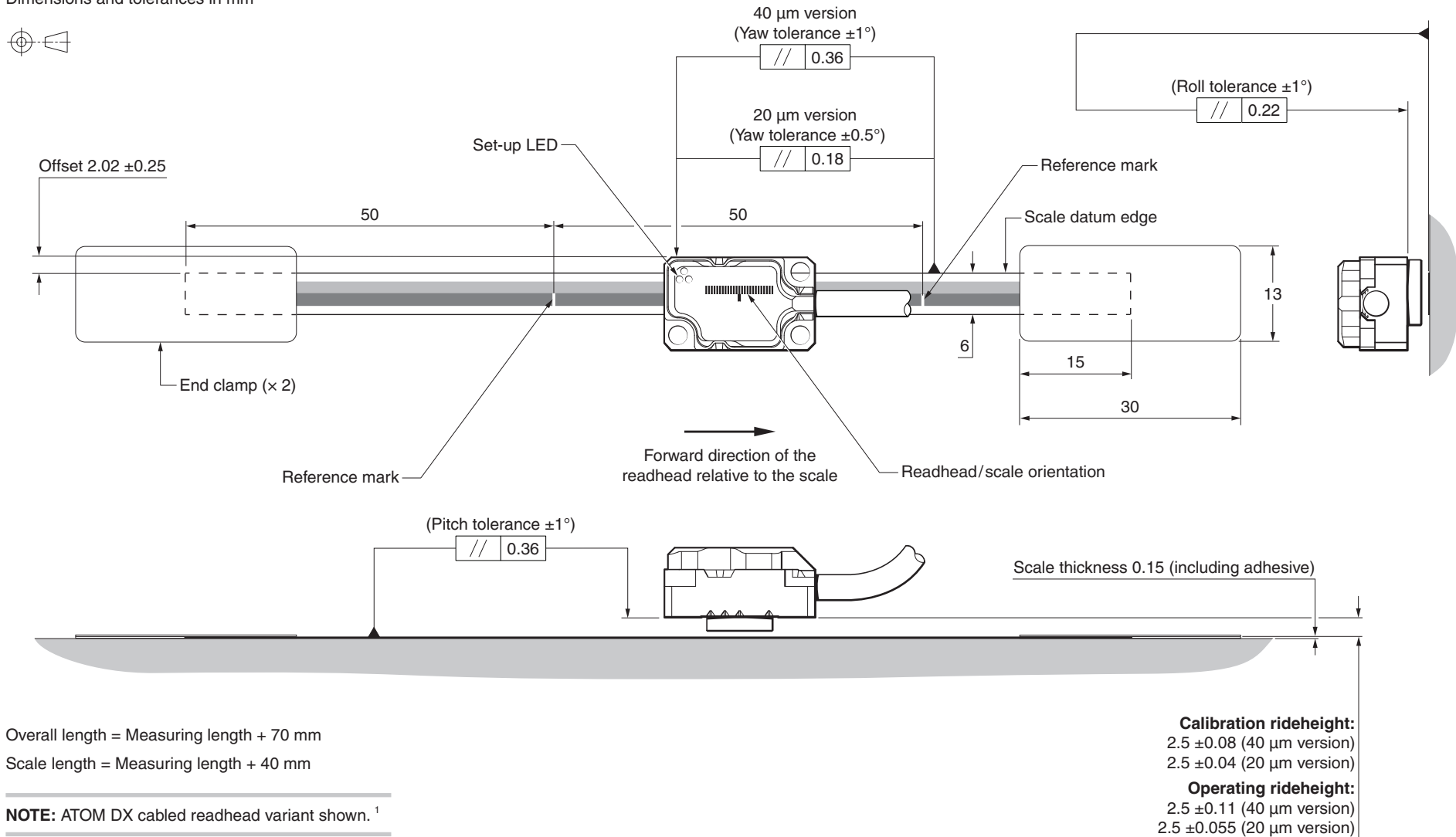

Overall length = Measuring length + 70 mm

Scale length = Measuring length + 40 mm

NOTE: ATOM DX cabled readhead variant shown. ¹

¹ For readhead dimensions see pages 35 and 36.

RKLF application methods

The RKLF scale application method depends upon the bracket type being used.

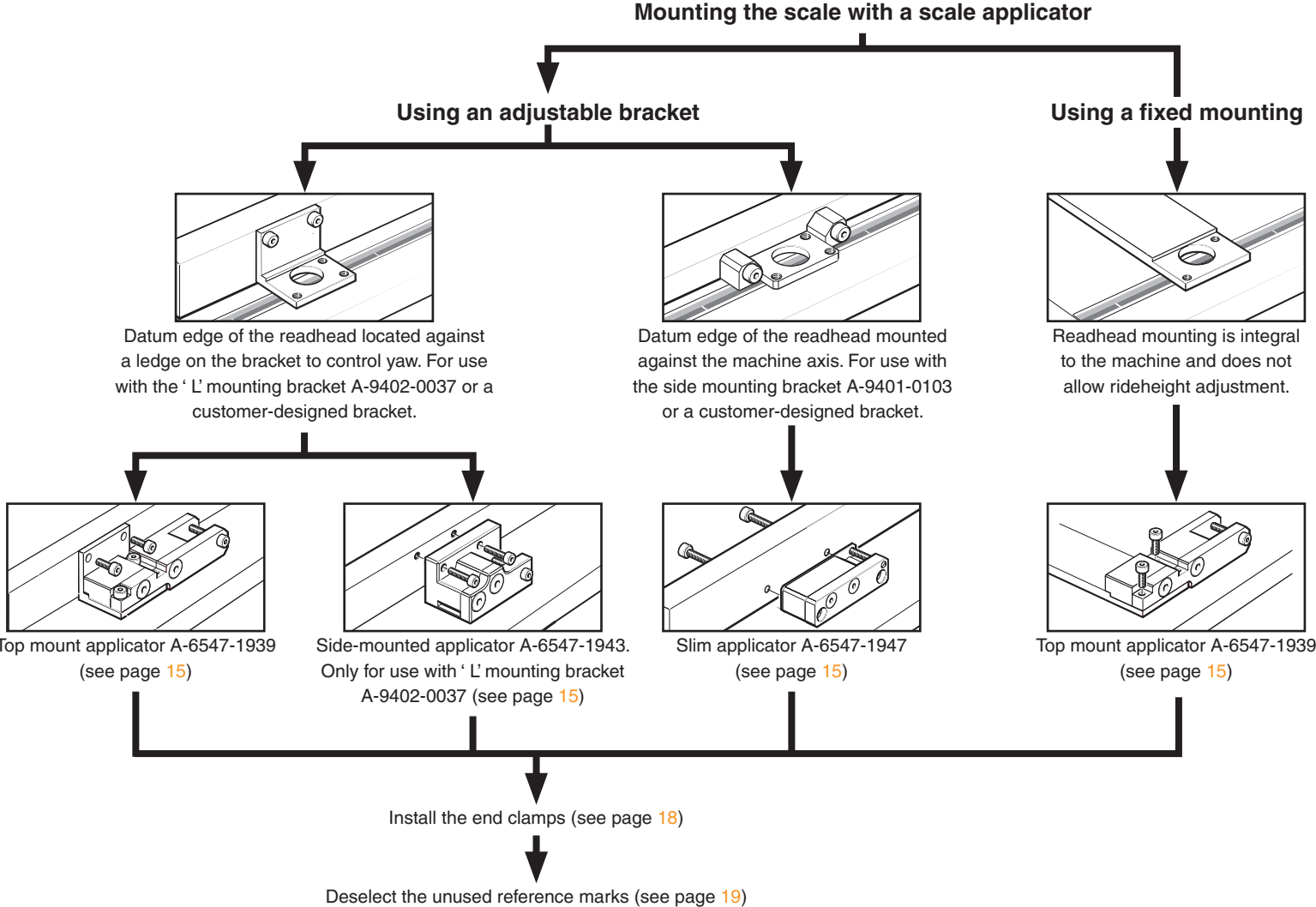

Equipment required for mounting the RKLf with a scale applicator

Required parts:

- An appropriate length of RKLf tape scale (see 'RKLf tape scale installation drawing' on page 13)
- Appropriate cleaning solvents (see 'Storage and handling' on page 10)
- End clamp kit (A-9523-4015)
- RGG-2 two part epoxy adhesive (A-9531-0342)
- Readhead mounting bracket (see table below)
- Appropriate scale applicator (see table below)
- 2 × applicator mounting screws
- 2 M2 × 6 screws, top mount applicator only

Optional parts:

- Renishaw scale wipes (A-9523-4040)
- Reference mark deselection stickers (A-9402-0049 for a sheet of 20)
- Lint-free cloth

Readhead mounting bracket and scale applicator:

The correct version of the scale applicator that should be used depends upon the design of the readhead mounting bracket being used. For more information on designing your bracket, contact your local Renishaw representative.

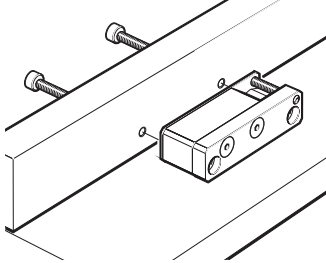
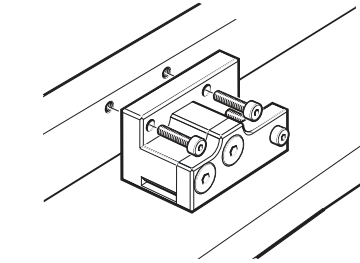
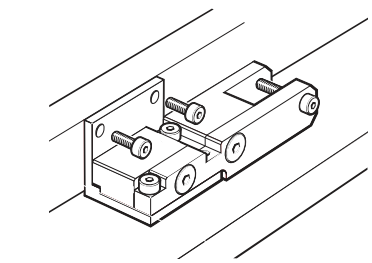
	Slim applicator (A-6547-1947)	Side mount applicator (A-6547-1943)	Top mount applicator (A-6547-1939)
			
Mounting	In place of the readhead bracket	In place of the readhead bracket	In place of the readhead
Applicable bracket	Side mounting bracket (A-9401-0103) or a customer-designed bracket	'L' mounting bracket (A-9402-0037) or a customer-designed bracket	'L' mounting bracket (A-9402-0037) or a customer-designed bracket

RKLF scale application

1. Allow the RKLF scale to acclimatise to the installation environment prior to installation.

NOTE: The scale should be installed between +10 °C and + 35 °C to ensure scale mastering.

2. Mark out the start position for the scale on the axis substrate.

NOTE: Ensure that there is room for the end clamps (see 'RKLF tape scale installation drawing' on page 13).

3. Thoroughly clean and degrease the substrate using recommended solvents (see 'Storage and handling' on page 10). Allow the substrate to dry before applying the scale.
4. Mount the chosen scale applicator (see 'Readhead mounting bracket and scale applicator:' on page 15).
5. Move axis to the start of travel leaving enough room for the scale to be inserted through the applicator, as shown below.
6. Check the correct scale orientation (see 'RKLF tape scale installation drawing' on page 13).

7. **Slim or side mount applicators:**

- Begin to peel off the backing paper from the end of the scale and insert the scale into the applicator up to the start position.
- Ensure the backing paper feeds out of the back of the applicator around the splitter screw as shown on the following page.

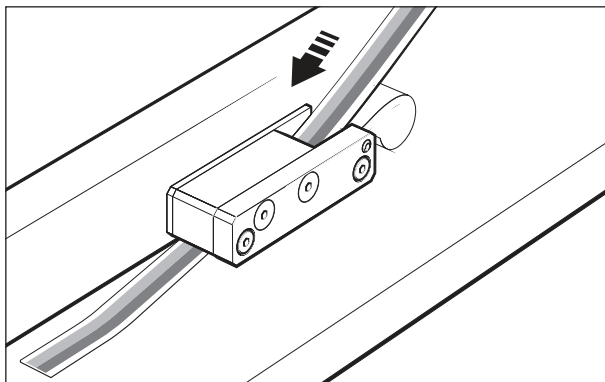

Top mount applicator:

- Cut the backing paper approximately 30 mm from the end of the scale.
- Leaving the end piece adhering to the scale, begin to peel off the remaining backing paper.
- Insert the scale into the applicator up to the start position.
- Ensure the backing paper feeds out of the back of the applicator

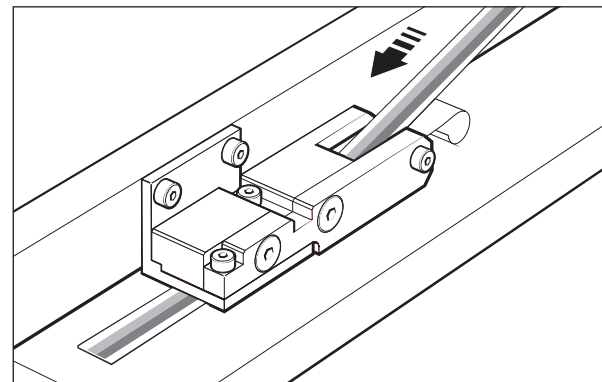

8. Apply firm finger pressure via a clean, dry, lint-free cloth to ensure the scale end adheres well to the substrate.
9. Slowly and smoothly move the applicator through the entire length of travel, ensuring the backing paper is pulled manually from the scale and does not catch under the applicator.

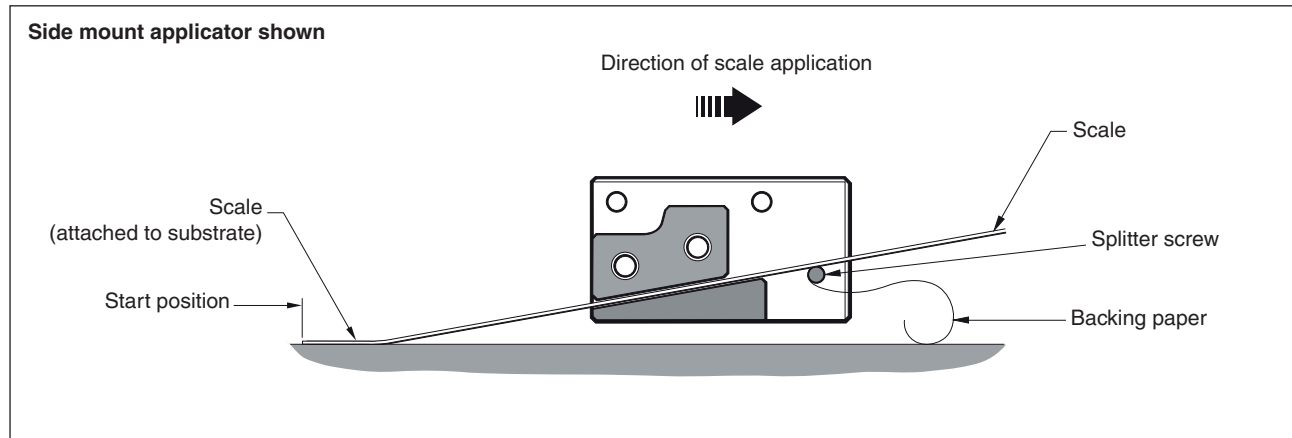

10. Remove the applicator and, if necessary, adhere the remaining scale manually.

NOTE: When using the top mount applicator ensure the backing paper left at the start of the axis is removed.

11. Apply firm finger pressure via a clean, dry, lint-free cloth along the length of the scale after application to ensure complete adhesion.
12. Remove the applicator and, if necessary, adhere the remaining scale manually.

NOTE: Slim and side mount applicators only: Fit the readhead mounting bracket after removal of scale applicator.

13. Clean the scale using Renishaw scale wipes or a clean, dry, lint-free cloth.
14. Fit the end clamps (see ['Fitting the end clamps'](#) on page 18) and, if needed, deselect the reference marks that are not required (see ['RKLf reference mark deselection'](#) on page 19).

Fitting the end clamps

The end clamp kit is designed to be used with Renishaw RKLf scale to ensure the scale is mastered to the substrate. Alternative narrow 6 mm wide end clamps (A-9523-4111) are also available.

NOTE: End clamps can be mounted before or after readhead installation.

1. Clean both ends of the scale and the area where the end clamps are to be fitted using Renishaw scale wipes or one of the recommended solvents (see 'Storage and handling' on page 10).

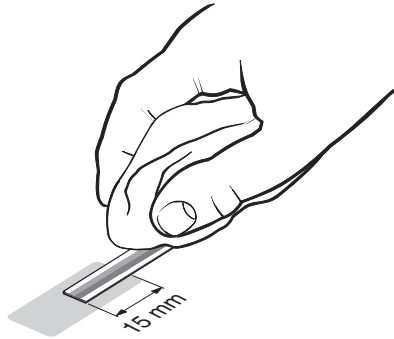

2. Thoroughly mix up a sachet of RGG-2 two-part epoxy adhesive and apply a small amount to the underside of the end clamp.

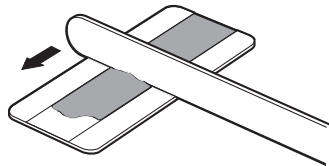

3. The end clamp features two small regions of contact adhesive. These will temporarily hold the end clamp in position while the epoxy cures. Remove the backing tape from either side.

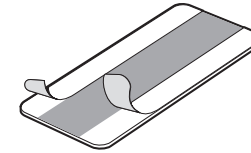

4. Immediately position the end clamp over the end of the scale and push down to ensure complete adhesion. Allow 24 hours at 20 °C for a full cure.¹

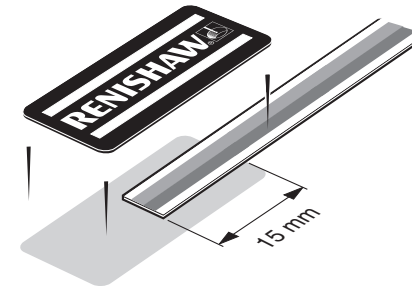

CAUTION: Ensure that excess epoxy is wiped away from the scale as it may affect the readhead signal level.

¹ To ensure scale end movement of typically < 1 µm, stabilise the system at least 5 °C higher than the maximum customer application temperature for a minimum of 8 hours. For example: Customer application = 23 °C axis temperature. Stabilise the system at 28 °C for a minimum of 8 hours.

RKLF reference mark deselection

RKLF tape scale > 100 mm in length has reference marks every 50 mm. Stickers can be used to deselect all of the unused reference marks. The stickers are aligned on the backing paper with a 50 mm spacing so two can be selected at once for deselecting two reference marks.

1. Ensure the scale is free from dirt and grease by cleaning with a Renishaw scale wipe or one of the recommended solvents (see 'Storage and handling' on page 10).
2. Place the transparent applicator film over the reference mark deselector stickers and rub firmly until the sticker adheres to the applicator film. Two stickers can be selected at once.
3. Remove the applicator film, complete with the stickers, from the backing paper.

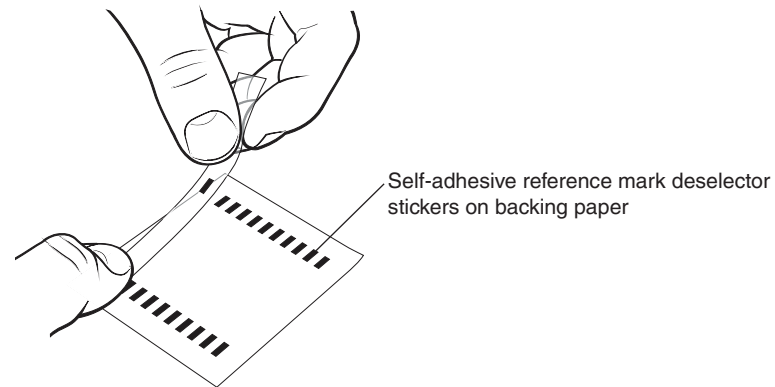

4. Align the stickers on the scale over the reference marks that are not required, as shown in the diagram below, then rub firmly on the applicator film until the stickers adhere to the scale. Care should be taken to ensure the stickers fully cover the reference mark and do not obscure any of the incremental track.

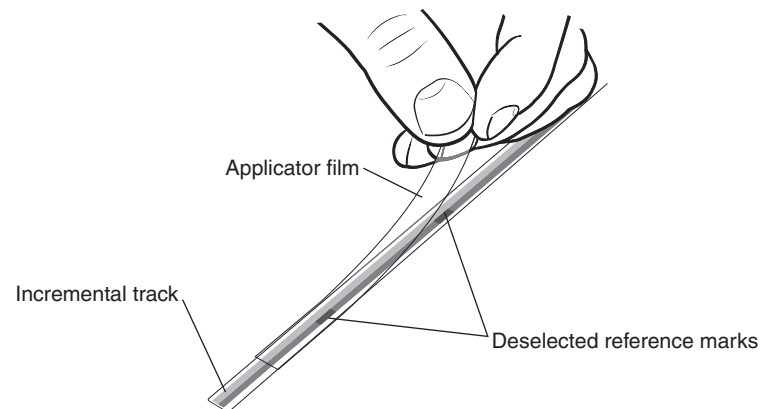

5. Remove the applicator film.

System connection: Top exit readhead

A range of cables for top exit readheads are available;

15-way D-type connector	
Cable length (m)	Part number
0.5	A-9414-1223
1.0	A-9414-1225
1.5	A-9414-1226
3.0	A-9414-1228

10-way JST	
Cable length (m)	Part number
0.5	A-9414-1233
1.0	A-9414-1235
1.5	A-9414-1236
3.0	A-9414-1238

- Provide appropriate strain relief at the readhead. The Renishaw top exit cables are fitted with a P-clip to ensure appropriate cable strain relief.
- When using Renishaw's top exit cables ensure that the P-clip is mounted within a 50 mm radius of the readhead cable exit.
- The minimum static bend radius of cores is 3 mm.
- For challenging dynamic applications consider additional strain relief of the cores.
- Ensure there is no relative movement between the readhead and the P-clip.
- The maximum number of insertions for the readhead connector is 20 cycles. Care should be taken when removing the connector to avoid pulling out cores from the cable connector.

Shielding

For optimum performance:

- Ensure 100% shielding.
- Ground the mounting brackets.
- Ensure continuity between the readhead body and cable shield. For Renishaw top exit cables the P-clip provides electrical connection to the cable shield.
- Maximise the distance between the encoder and motor cables.

Top exit readhead (with readhead cable inserted)

Dimensions and tolerances in mm

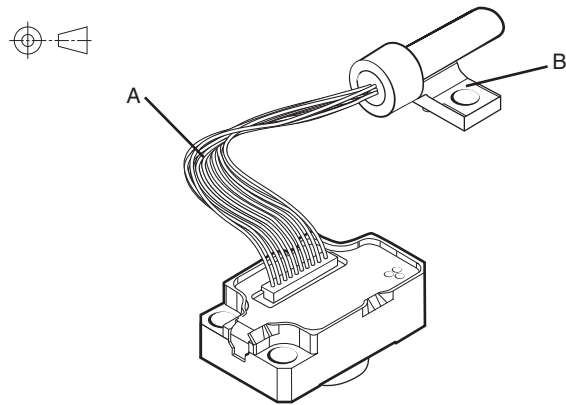

Detail A: Connector (readhead end) and P-clip

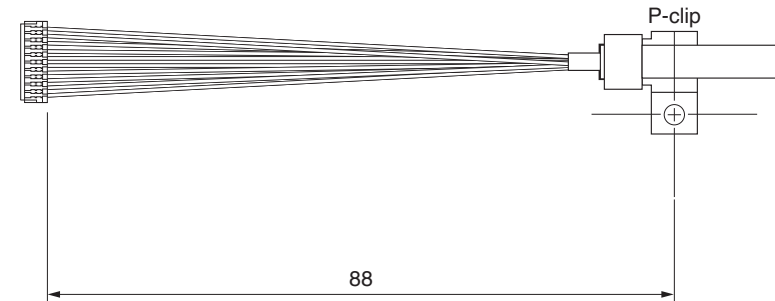

Detail B: P-clip dimensions

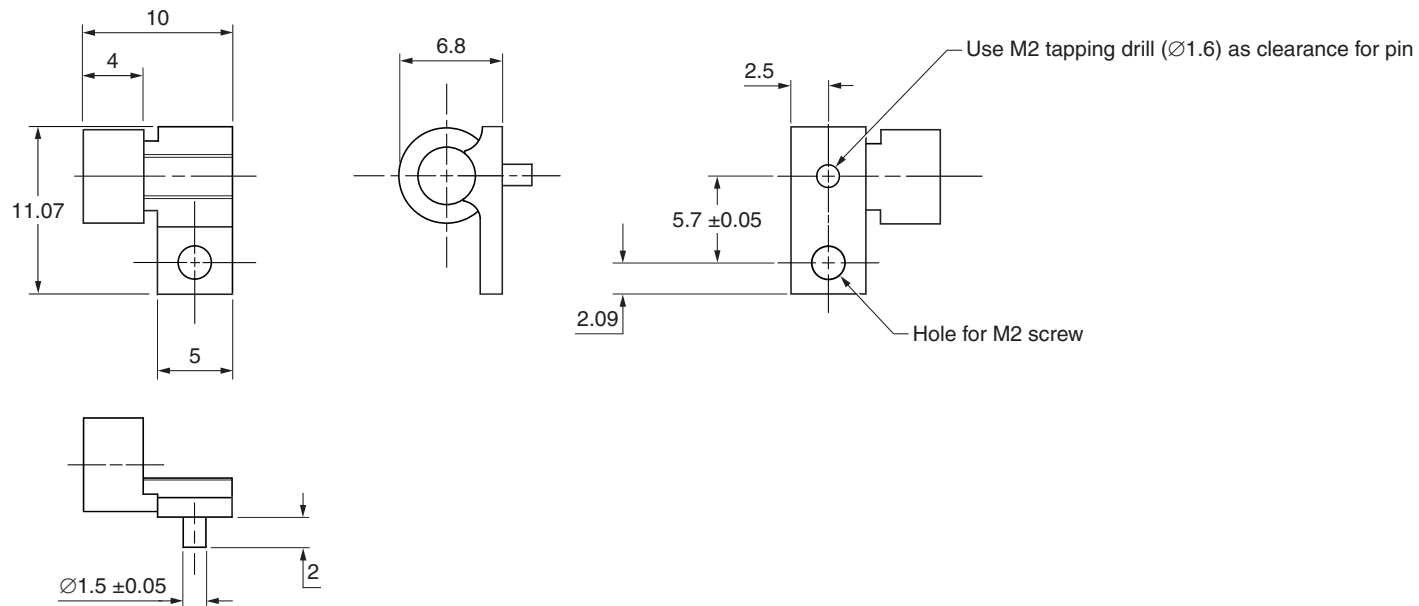

Readhead mounting and alignment: Methods

There is a range of tools available to assist with readhead installation depending upon the system design and these are detailed below. For more details on designing the mounting bracket and selecting the appropriate mounting tools contact your local Renishaw representative.

Ensure that the scale, readhead optical window and mounting face are clean and free from obstruction.

CAUTION: Do not saturate the readhead window with cleaning solvent as this may cause contamination on the inside of the readhead window which then cannot be cleaned.

IMPORTANT: Whichever method is used to mount the readhead, care should be taken to ensure the scale surface is not damaged during this operation, particularly when metal-to-metal contact is necessary.

NOTE: Cabled readheads are shown in the following pages, but the same readhead mounting and alignment methods are applicable for top exit readheads.

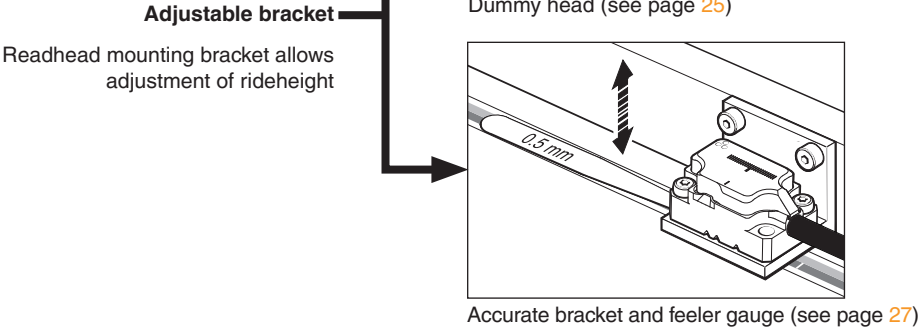
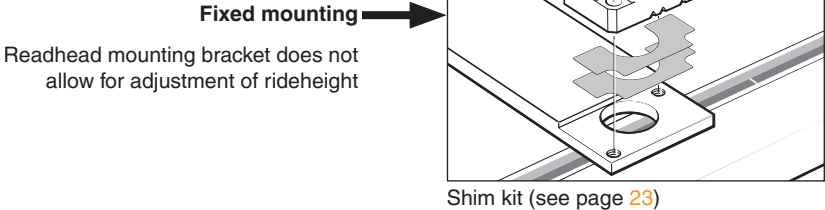

Shim kit (A-9401-0050)

This method is intended for applications where the rideheight of the readhead cannot be adjusted.

The system should be designed to achieve a nominal 2.3 mm (± 0.2 mm) from the readhead mounting surface to the top of the scale.

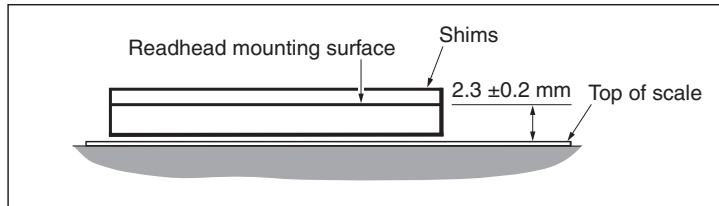

Shims of a known thickness are inserted between the mounting face of the readhead and the bracket to give the correct rideheight of 2.5 mm (± 0.2 mm).

Required parts

- Dial test indicator (DTI) or similar
- 2 M2 × 6 screws
- ATOM readhead shim kit (A-9401-0050) consisting of:

Part number	Thickness (μm)	Quantity in pack
A-9401-0041	20	10
A-9401-0042	40	10
A-9401-0043	60	10
A-9401-0044	80	10
A-9401-0045	100	20
A-9401-0046	200	20
A-9401-0047	300	10

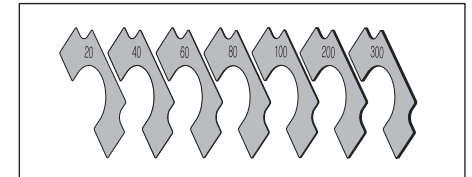

- Hex key
- ATOM DX readhead

Optional parts

- DTI adaptor (A-9401-0105)

1. Using a dial test indicator or similar, measure the distance from the readhead mounting surface to the scale surface.

Care must be taken to ensure the scale surface is not scratched. Renishaw offer a DTI adaptor that can be used to assist with this process.

- Insert the DTI into the adaptor and zero it on a flat surface.
- Position or fix the indicator/adaptor in place of the readhead and measure the distance to the scale surface.

Contact your local Renishaw representative for details of the DTI and adaptor.

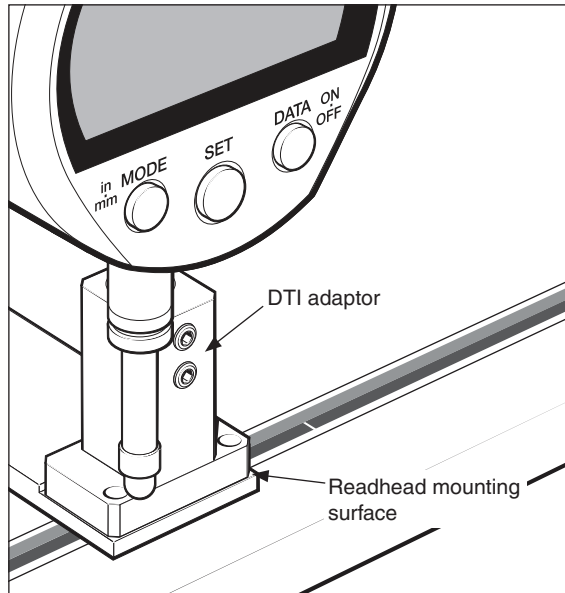

2. Subtract the distance measured from the nominal rideheight of 2.5 mm to calculate the required shim thickness. For example if the distance measured is 2.37 mm the required shim thickness is 130 μm .

3. Select the smallest number of shims that gets within 10 μm of the difference. For distances less than 100 μm a single shim should be used; for distances greater than 100 μm select one thick ($\geq 100 \mu\text{m}$) and one thin ($< 100 \mu\text{m}$) shim.

In the above example of a required shim thickness of 130 μm this could either be: 1 \times 100 μm shim and 1 \times 40 μm shim or 1 \times 100 μm shim and 1 \times 20 μm shim.

4. Place the chosen shim(s) between the readhead and the bracket.
5. Fix the readhead to the bracket using 2 M2 \times 6 screws in diagonally opposite fixing holes, ensuring the readhead is tightened down evenly and parallel to the bracket face.

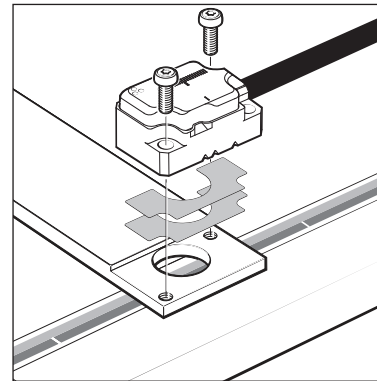

6. Connect the readhead to the receiving electronics and power-up.
7. Check the readhead set-up LED is flashing green along the full axis of travel.
8. Proceed with 'System calibration' on page 29.

Dummy head (A-9401-0072)

The reusable dummy head has the same mounting holes as the ATOM DX readhead with a longer 'nose' that is machined to the optimum rideheight (2.5 mm ±0.02 mm).

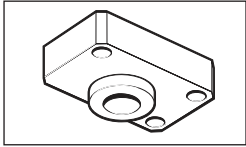

It is mounted in place of the readhead directly onto the bracket. The bracket should have location pins or a shoulder to control readhead yaw. Contact your local Renishaw representative for more information on bracket design.

Required parts

- Dummy head (A-9401-0072)
- 2 M2 × 6 screws
- Side mount bracket (A-9401-0103), 'L' mounting bracket (A-9402-0037), or customer designed bracket ¹
- 2 bracket mounting screws
- Hex key
- ATOM DX readhead

1. Mount the dummy head onto the bracket using 2 M2 × 6 screws.

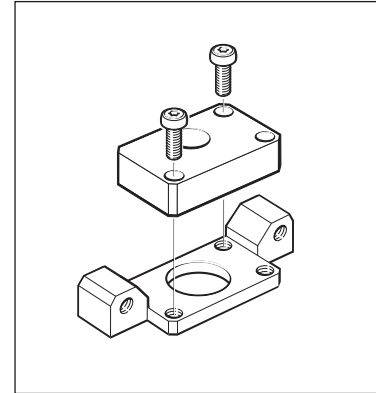

Side mount bracket

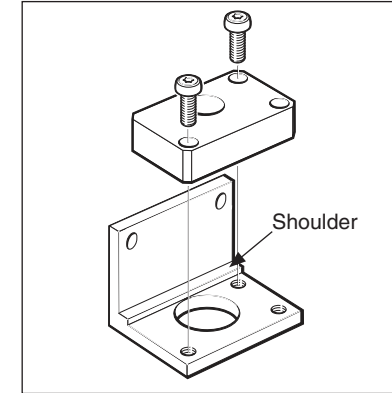

'L' mounting bracket

2. Loosely mount the readhead bracket onto the axis.

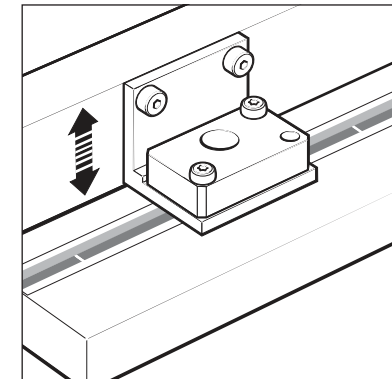
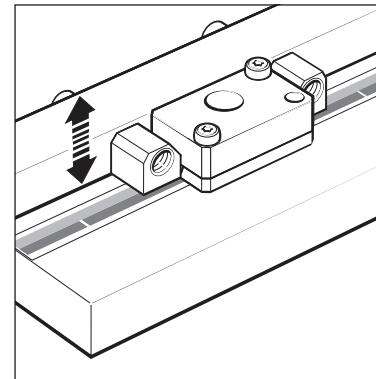

3. Adjust the height of the bracket until the 'nose' of the dummy head just touches the scale.

¹ For more information on bracket design contact your local Renishaw representative.

4. Tighten the bracket fixing screws whilst ensuring good contact between the 'nose' of the dummy head and the surface of the scale.

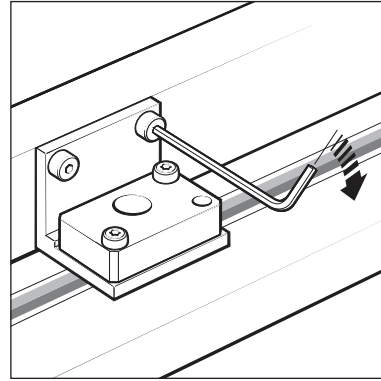
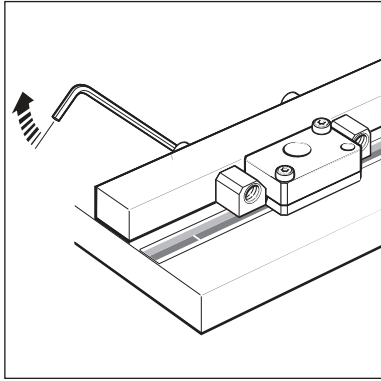

5. Remove the dummy head.
6. Install the ATOM DX readhead in place of the dummy head using 2 M2 x 6 screws in diagonally opposite fixing holes. Ensure the readhead is pushed back against the shoulder of the bracket or the mounting face.

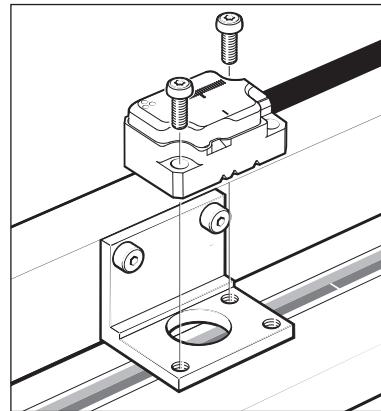
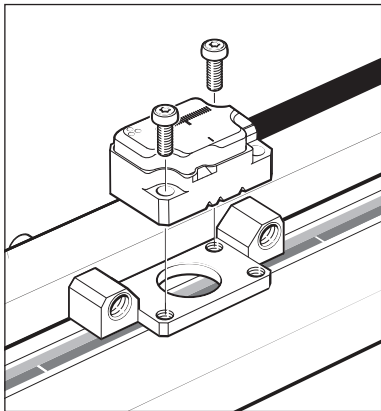

7. Connect the readhead to the receiving electronics and power-up.
8. Check the readhead set-up LED is flashing green along the full axis of travel.
9. Proceed with '[System calibration](#)' on page 29.

Accurate bracket and feeler gauge

For applications where the readhead mounting bracket allows adjustment of rideheight with a bracket thickness of 2 ± 0.02 mm.

Required parts

- 'L' mounting bracket (A-9402-0037) or a customer designed bracket with a thickness of 2 ± 0.02 mm.¹
- 2 bracket mounting screws
- 0.5 mm feeler gauge
- 2 M2 × 6 screws
- Hex key
- ATOM DX readhead

1. Mount the readhead onto the bracket.
2. Loosely mount the readhead bracket onto the axis.
3. Place the feeler gauge between the readhead bracket and the scale.

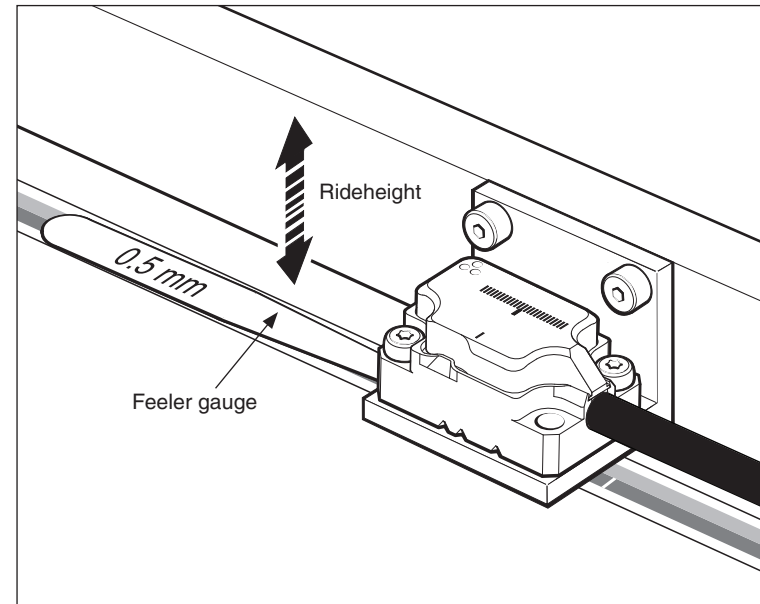

4. Tighten the bracket fixing screws whilst ensuring good contact between the bracket, shim and surface of the scale.
5. Connect the readhead to the receiving electronics and power-up.
6. Check the readhead set-up LED is flashing green along the full axis of travel.
7. Proceed with '[System calibration](#)' on page 29.

¹ For more information on bracket design contact your local Renishaw representative.

ATOM DX calibration overview

This section is an overview of the calibration procedure for an ATOM DX encoder system. More detailed information on calibrating the readhead is contained on page 29 of this installation guide. The optional Advanced Diagnostic Tool ADTi-100¹ (A-6195-0100) and ADT View software² can be used to aid installation and calibration.

Calibrate system

Ensure the readhead set-up LED is flashing green along the full axis of travel before system calibration. See page 22 to page 27 for more information on readhead mounting and alignment.

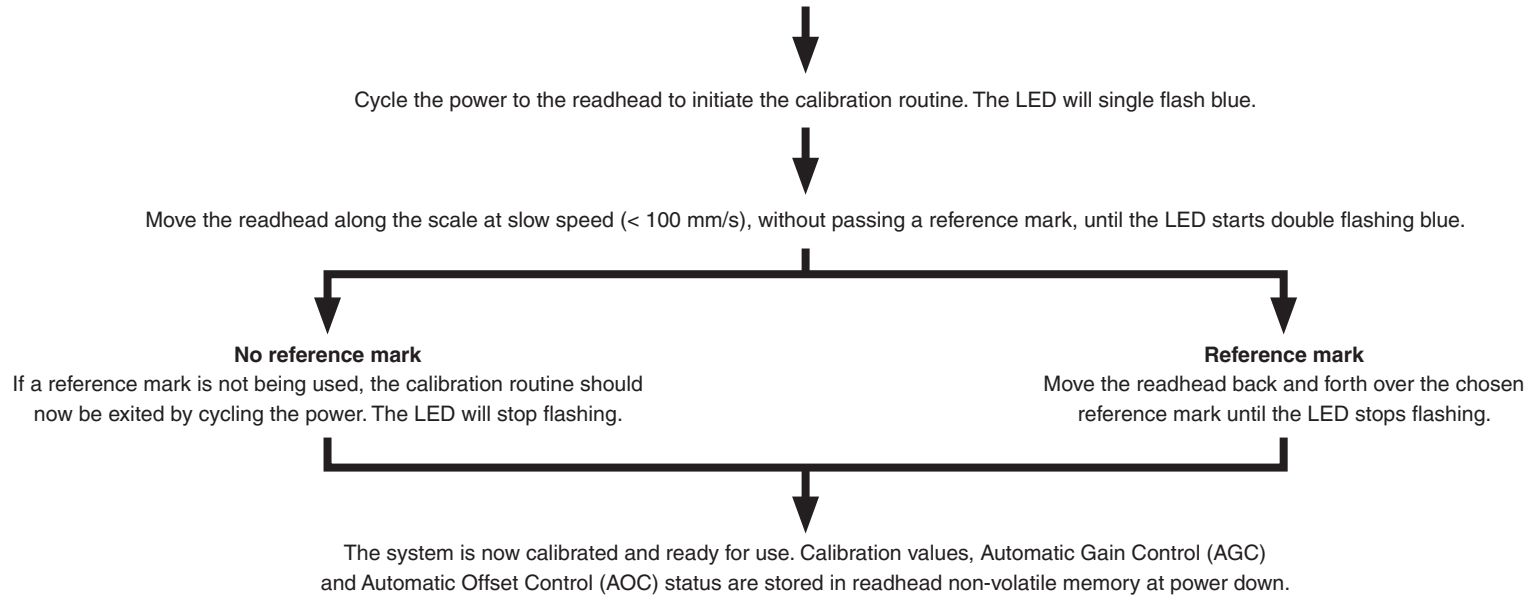

NOTE: If the calibration routine fails (the readhead LED remains single flashing blue), restore the readhead factory defaults (see 'Restoring factory defaults' on page 30) and repeat the installation and calibration routine.

¹ For more details refer to the *Advanced Diagnostic Tool ADTi-100 and ADT View software User guide* (Renishaw part no. M-6195-9413) and *Advanced Diagnostic Tool ADTi-100 and ADT View software Quick-start guide* (Renishaw part no. M-6195-9321).

² The software can be downloaded for free from www.renishaw.com/adt.

System calibration

NOTE: The functions described below can also be carried out by using the optional ADTi-100 and ADT View software. See www.renishaw.com/adt for more information.

Before system calibration:

1. Clean the scale and the readhead's optical window.
2. If reinstalling, restore the readhead's factory defaults (see 'Restoring factory defaults' on page 30).
3. Maximise the signal strength along the full axis of travel (the readhead set-up LED is flashing green).

NOTE: During calibration the speed should not exceed 100 mm/s or the readhead's maximum speed, whichever is slowest.

Incremental signal calibration

1. Cycle the power to the readhead or connect the 'Remote CAL' output pin to 0 V for < 3 seconds. The readhead will then single flash blue to indicate it is in calibration mode. The readhead will only enter calibration mode if the LED is flashing green.
2. Move the readhead at slow speed along the axis, ensuring that it does not pass a reference mark, until the LED starts double-flashing. This indicates that the incremental signals are now calibrated and the new settings are stored in the readhead memory.
3. The system is now ready for the reference mark phasing. For systems without a reference mark, cycle the power to the readhead or connect the 'Remote CAL' output pin to 0 V for < 3 seconds to exit the calibration mode.
4. If the system does not automatically enter the reference mark phasing stage (LED continues single flashing) the calibration of the incremental signals has failed. After ensuring failure is not due to overspeed, exit the calibration routine, restore the readhead's factory defaults (see 'Restoring factory defaults' on page 30) and check the readhead installation and system cleanliness before repeating the calibration routine.

Reference mark phasing

1. Move the readhead back and forth over the reference mark until the LED stops flashing and remains solid blue. The reference mark is now phased.
2. The system automatically exits the calibration routine and is ready for operation.
3. AGC is automatically switched on once calibration is complete. To switch off AGC refer to 'Switching Automatic Gain Control (AGC) on or off' on page 30.
4. If the LED continues double-flashing blue after repeatedly passing the reference mark it is not being detected.
 - Ensure that the readhead orientation and alignment are correct.

Calibration routine manual exit

To exit the calibration routine at any stage cycle the power to the readhead or connect the 'Remote CAL' output pin to 0 V for < 3 seconds. The LED will then stop flashing.

LED status during system calibration

LED	Settings stored
Blue single flashing	None, restore factory defaults and recalibrate
Blue double flashing	Incremental only
Blue (auto-complete)	Incremental and reference mark

NOTE: For full readhead LED diagnostics see page 31.

Restoring factory defaults

When reinstalling the system, or in the case of continued calibration failure, factory defaults should be restored.

NOTE: Restoring factory defaults can also be carried out using the optional ADTi-100 and ADT View software. See www.renishaw.com/adt for more information.

To restore factory defaults:

1. Switch system off.
2. Obscure the readhead optical window or connect the 'Remote CAL' output pin to 0 V.
3. Power the readhead.
4. Remove the obstruction or, if using, the connection from the 'Remote CAL' output pin to 0 V.
5. The readhead set-up LED will start continuously flashing indicating factory defaults have been restored and the readhead is in installation mode.
6. Repeat the system calibration (see 'System calibration' on page 29).

Switching Automatic Gain Control (AGC) on or off

The AGC is automatically enabled once the system has been calibrated (indicated by a solid blue LED). AGC can be manually switched off by connecting the 'Remote CAL' output pin to 0 V for > 3 seconds < 10 seconds. The readhead set-up LED will then be solid green.

NOTE: AGC can be switched on or off using the optional ADTi-100 and ADT View software. See www.renishaw.com/adt for more information.

Readhead LED diagnostics

Mode	LED	Status
Installation mode	Green flashing	Good set-up, maximise flash rate for optimum set-up
	Orange flashing	Poor set-up, adjust readhead to obtain green flashing LED
	Red flashing	Poor set-up, adjust readhead to obtain green flashing LED
Calibration mode	Blue single flashing	Calibrating incremental signals
	Blue double flashing	Calibrating reference mark
Normal operation	Blue	AGC on; optimum set-up
	Green	AGC off; optimum set-up
	Red	Poor set-up; signal may be too low for reliable operation
	Blank flash	Reference mark detected (visible indication at speed < 100 mm/s only)
Alarm	4 red flashes	Low signal or over signal; system in error

Troubleshooting

Fault	Cause	Possible solutions
LED on the readhead is blank	There is no power to the readhead	<ul style="list-style-type: none"> • Check you have 5 V at the readhead • For cable variants check correct wiring of connector
LED on the readhead is red and I can't get a green LED	The signal strength is < 50%	<ul style="list-style-type: none"> • Check the readhead optical window and scale are clean and free from contamination • Restore factory defaults (see page 30) and check alignment of the readhead. In particular; <ul style="list-style-type: none"> • Rideheight • Yaw • Offset • Check the scale and readhead orientation • Check that the readhead variant is the correct type for the chosen scale (see the <i>ATOM DX™ miniature encoder system</i> data sheet (Renishaw part no. L-9517-9736) for details of readhead configuration)
Unable to get a flashing Green LED over the complete axis length	System run-out is not within specification	<ul style="list-style-type: none"> • Check that the readhead variant is the correct type for the chosen scale (see the <i>ATOM DX™ miniature encoder system</i> data sheet (Renishaw part no. L-9517-9736) for details of readhead configuration) • Use a DTI gauge and check the run-out is within specifications • Restore factory defaults • Realign the readhead to obtain a flashing green LED at the mid-point of the run-out • Recalibrate the system (see page 29)
Can't initiate the calibration routine	Signal size is < 70%	<ul style="list-style-type: none"> • Restore factory defaults • Realign the readhead to obtain a flashing green LED

Fault	Cause	Possible solutions
LED on the readhead remains single flashing blue even after moving it along the full axis length	The system has failed to calibrate the incremental signals due to the signal strength being < 70%	<ul style="list-style-type: none"> • Exit CAL mode and restore factory defaults (see page 30) • Check system set-up and realign the readhead to obtain a flashing green LED along the full axis of travel before recalibrating
During calibration the LED on the readhead is double flashing blue even after moving it past the reference mark several times	The readhead is not seeing a reference mark	<ul style="list-style-type: none"> • Ensure you are moving the readhead past your chosen reference mark several times • Check the scale/readhead orientation • Check the scale/readhead alignment • Check the readhead optical window and scale are clean and free from contamination • Check that the readhead variant is the correct type for the chosen scale (see the <i>ATOM DX™ miniature encoder system</i> data sheet (Renishaw part no. L-9517-9736) for details of readhead configuration)
No reference mark output		<ul style="list-style-type: none"> • Ensure you are not over-speeding the readhead during calibration mode (maximum speed < 100 mm/s) • Calibrate the system (see page 29) <ul style="list-style-type: none"> • If the system completes calibration mode then it has successfully seen and calibrated the reference mark. If you still don't see a reference mark then check the system wiring. • If the system does not calibrate the reference mark (readhead set-up LED remains double flashing blue) see above for possible solutions
Reference mark is not repeatable	Only the chosen reference mark that has been used in the calibration sequence is repeatable; other reference marks may not be phased	<ul style="list-style-type: none"> • Ensure you are using the reference mark that has been calibrated for referencing your system • The readhead bracket must be stable and not allow any mechanical movement of the readhead • Check any unused reference marks have been deselected • Clean the scale and the readhead optical window and check for damage then recalibrate the system (see page 29) over the chosen reference mark

Fault	Cause	Possible solutions
LED on the readhead is flashing red over the reference mark	The reference mark is not phased	<ul style="list-style-type: none"> • Ensure you are using the reference mark that has been calibrated for referencing your system as only this reference mark will be guaranteed to remain phased. The LED may flash red when passing other reference marks if they have not been deselected (see page 19) • Clean the scale and the readhead optical window and check for scratches then recalibrate the system over the chosen reference mark (see page 29)
Multiple reference marks output	Unused reference marks have not been deselected	<ul style="list-style-type: none"> • All unused reference marks should be deselected (see page 19) as only the calibrated reference mark will be repeatable • Check alignment of deselection stickers

ATOM DX cabled readhead dimensions

Dimensions and tolerances in mm

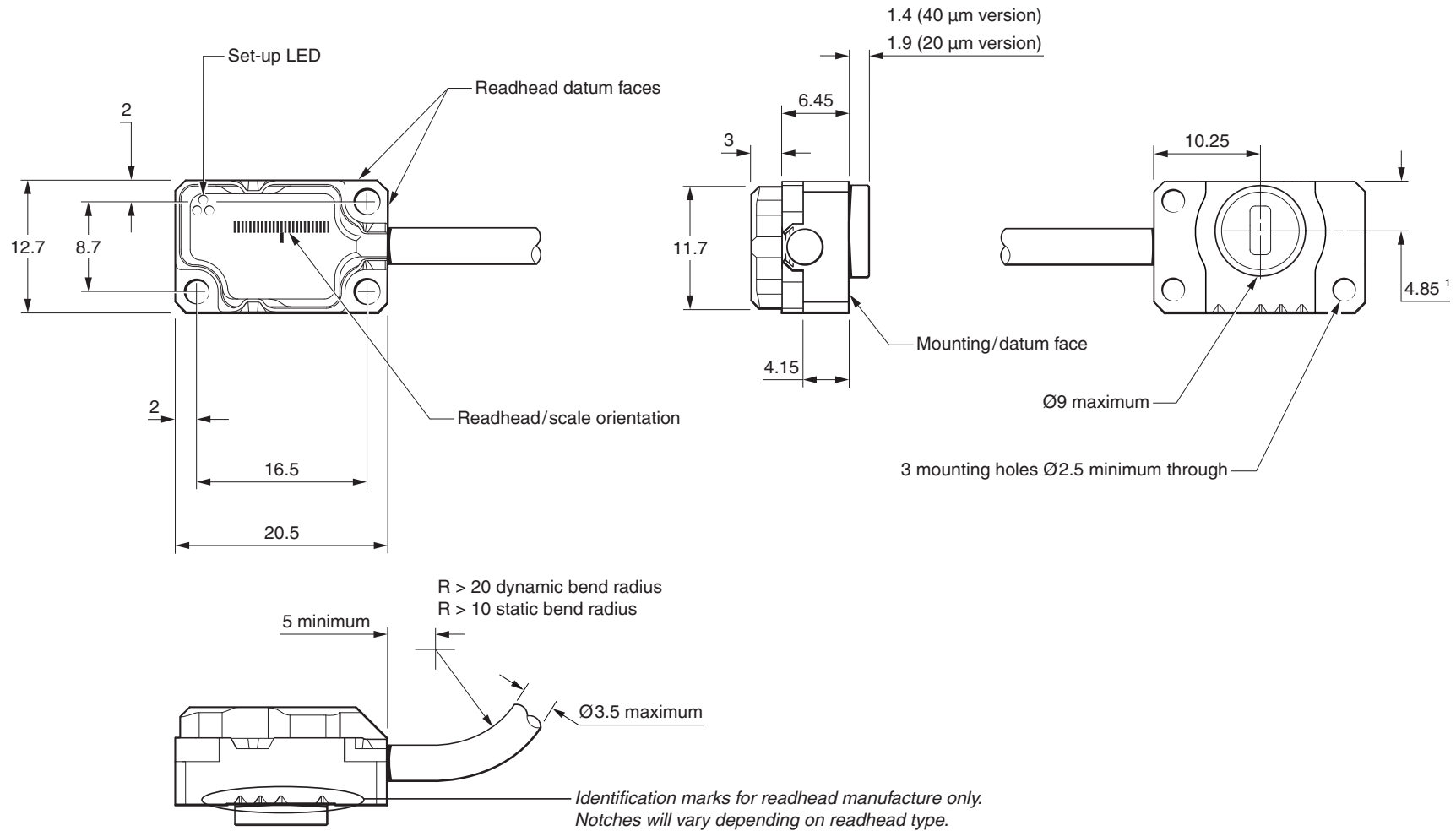

¹ Not the optical centreline

ATOM DX top exit readhead dimensions

Dimensions and tolerances in mm

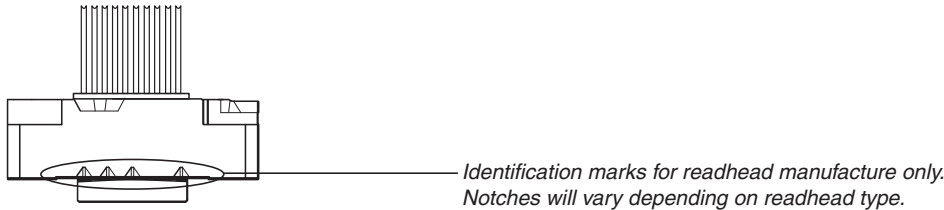
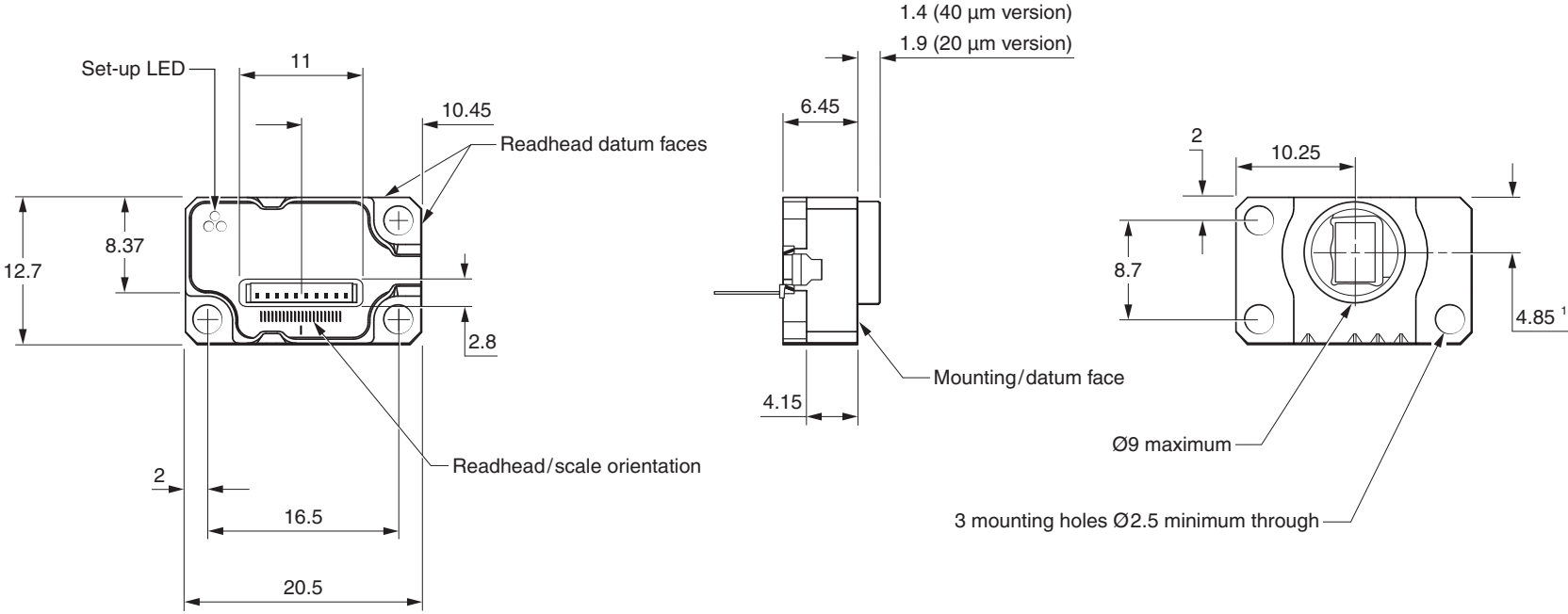

¹ Not the optical centreline

Bracket dimensions

Dimensions and tolerances in mm





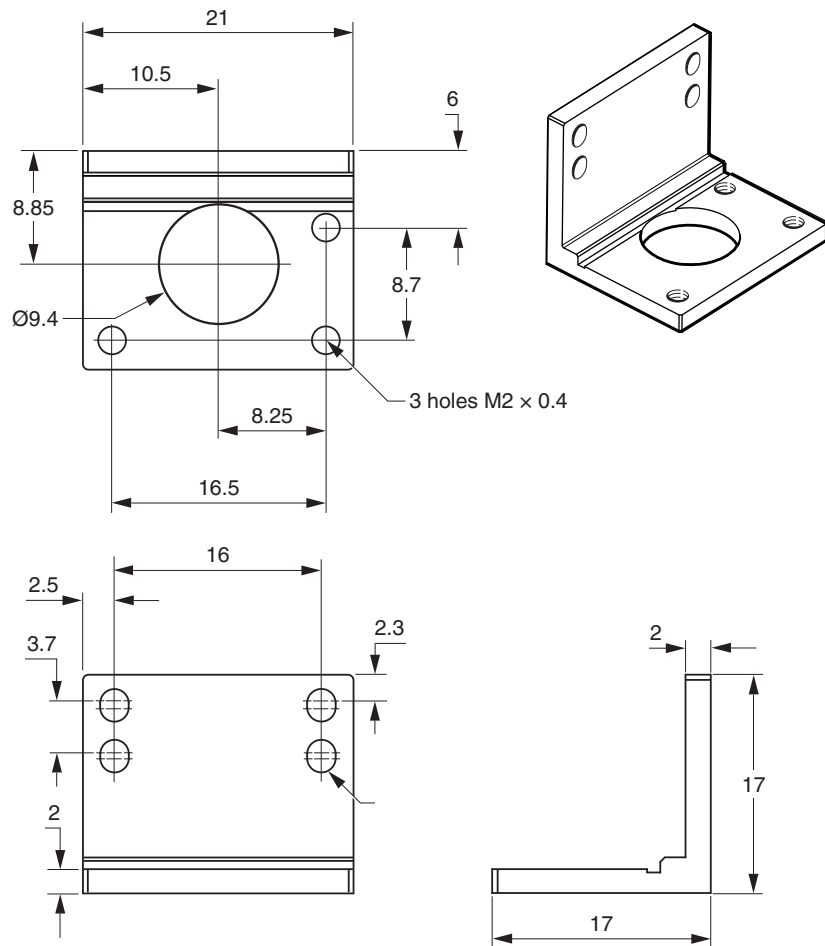

'L' mounting bracket (A-9402-0037)

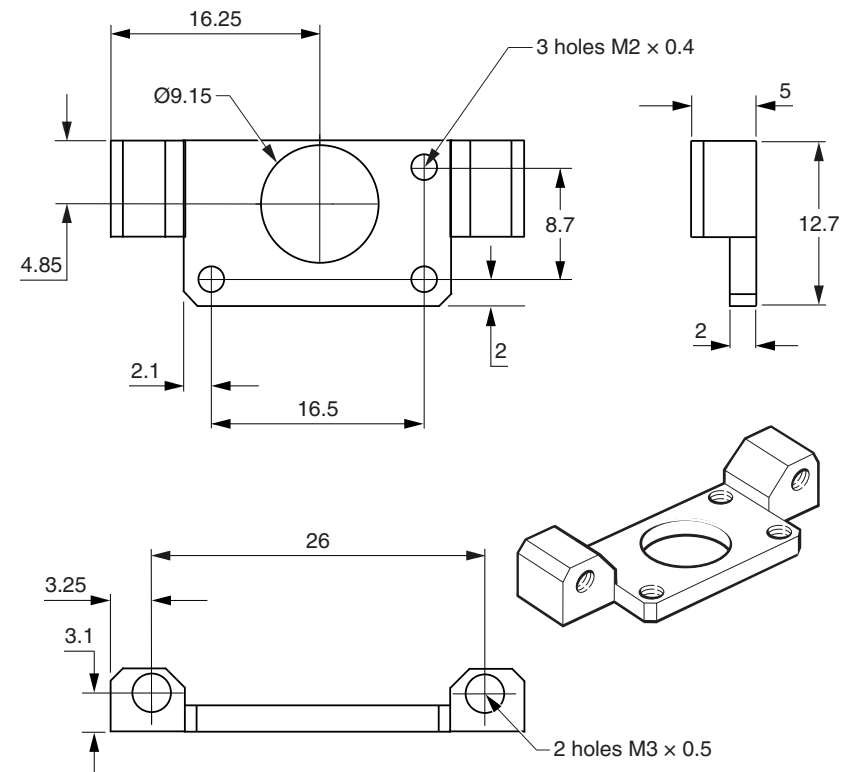

Side mount bracket (A-9401-0103)

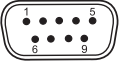
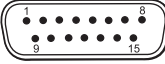

Output signals

			Cabled				Top exit (readhead)
							
Function	Signal	Colour	9-way D-type (A)	15-way D-type (D)	15-way D-type alternative pin-out (H)	10-way JST ¹ (K)	10-way JST ² (Z)
Power	5 V	Brown	5	7, 8	4, 12	10	10
	0 V	White	1	2, 9	2, 10	2	9
Incremental	A	+	2	14	1	9	5
		-	6	6	9	7	6
	B	+	4	13	3	4	8
		-	8	5	11	1	7
Reference mark	Z	+	3	12	14	8	4
		-	7	4	7	5	3
Alarm	E	Orange	-	3	13	6	2
Remote CAL ³	CAL	Clear	9	1	5	3	1
Shield	-	Screen	Case	Case	Case	Ferrule	-

NOTE: Top exit cables are terminated with the 'K' pin-out or the 'D' pin-out dependent upon which top exit readhead cable is used.

¹ PCB mount mating connectors: Top entry (BM10B-SRSS-TB); Side entry (SM10B-SRSS-TB).

² Connector on top exit readhead only: Mating connector (10SUR - 32S).

³ Remote CAL line must be connected for use with the ADTi-100.

Speed

20 µm ATOM DX readhead

Clocked output option (MHz)	Maximum speed (m/s)											Minimum edge separation ¹ (ns)
	Readhead type											
	D (5 µm)	X (1 µm)	Z (0.5 µm)	W (0.2 µm)	Y (0.1 µm)	H (50 nm)	M (40 nm)	I (20 nm)	O (10 nm)	Q (5 nm)	R (2.5 nm)	
50	10	10	10	7.25	3.63	1.813	1.450	0.725	0.363	0.181	0.091	25.1
40	10	10	10	5.80	2.90	1.450	1.160	0.580	0.290	0.145	0.073	31.6
25	10	10	9.06	3.63	1.81	0.906	0.725	0.363	0.181	0.091	0.045	51.0
20	10	10	8.06	3.22	1.61	0.806	0.645	0.322	0.161	0.081	0.040	57.5
12	10	10	5.18	2.07	1.04	0.518	0.414	0.207	0.104	0.052	0.026	90.0
10	10	8.53	4.27	1.71	0.85	0.427	0.341	0.171	0.085	0.043	0.021	109
08	10	6.91	3.45	1.38	0.69	0.345	0.276	0.138	0.069	0.035	0.017	135
06	10	5.37	2.69	1.07	0.54	0.269	0.215	0.107	0.054	0.027	0.013	174
04	10	3.63	1.81	0.73	0.36	0.181	0.145	0.073	0.036	0.018	0.009	259
01	4.53	0.91	0.45	0.18	0.09	0.045	0.036	0.018	0.009	0.005	0.002	1038

¹ For a readhead with a 1 m cable.

40 µm ATOM DX readhead

Clocked output option (MHz)	Maximum speed (m/s)												Minimum edge separation ¹ (ns)
	Readhead type												
	T (10 µm)	D (5 µm)	G (2 µm)	X (1 µm)	Z (0.5 µm)	W (0.2 µm)	Y (0.1 µm)	H (50 nm)	M (40 nm)	I (20 nm)	O (10 nm)	Q (5 nm)	
50	20	20	20	20	18.13	7.25	3.63	1.813	1.450	0.725	0.363	0.181	25.1
40	20	20	20	20	14.50	5.80	2.90	1.450	1.160	0.580	0.290	0.145	31.6
25	20	20	20	18.13	9.06	3.63	1.81	0.906	0.725	0.363	0.181	0.091	51.0
20	20	20	20	16.11	8.06	3.22	1.61	0.806	0.645	0.322	0.161	0.081	57.5
12	20	20	20	10.36	5.18	2.07	1.04	0.518	0.414	0.207	0.104	0.052	90.0
10	20	20	17.06	8.53	4.27	1.71	0.85	0.427	0.341	0.171	0.085	0.043	109
08	20	20	13.81	6.91	3.45	1.38	0.69	0.345	0.276	0.138	0.069	0.035	135
06	20	20	10.74	5.37	2.69	1.07	0.54	0.269	0.215	0.107	0.054	0.027	174
04	20	18.13	7.25	3.63	1.81	0.73	0.36	0.181	0.145	0.073	0.036	0.018	259
01	9.06	4.53	1.81	0.91	0.45	0.18	0.09	0.045	0.036	0.018	0.009	0.005	1038

¹ For a readhead with a 1 m cable.

Electrical connections

Grounding and shielding

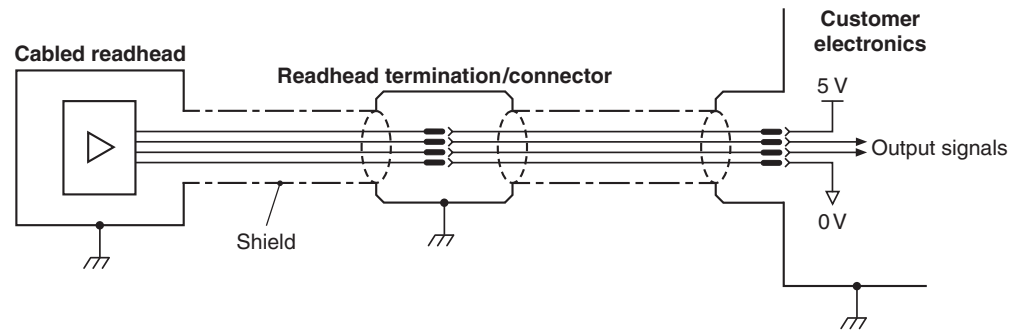

IMPORTANT: The shield should be connected to the machine earth (Field Ground). For JST variants the ferrule should be connected to the machine earth.

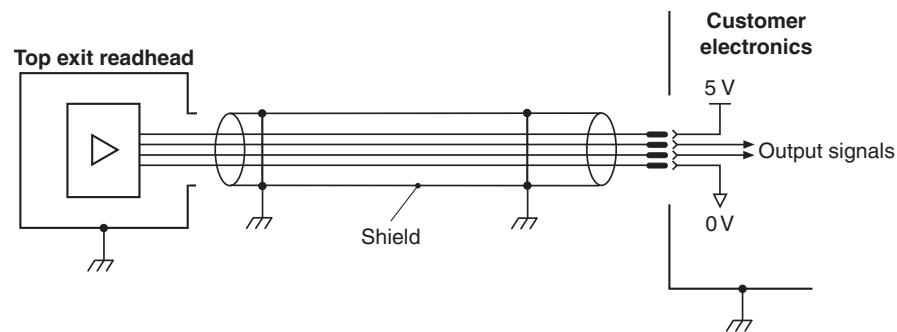

IMPORTANT: The shield should be connected to the machine earth (Field Ground).

NOTE: For Renishaw top exit readhead cables the shield connection is provided by the P-clip.

Maximum readhead cable length: 3 m

Maximum extension cable length: Dependent on cable type, readhead cable length and clock speed. Contact your local Renishaw representative for more information.

Recommended signal termination

Digital outputs

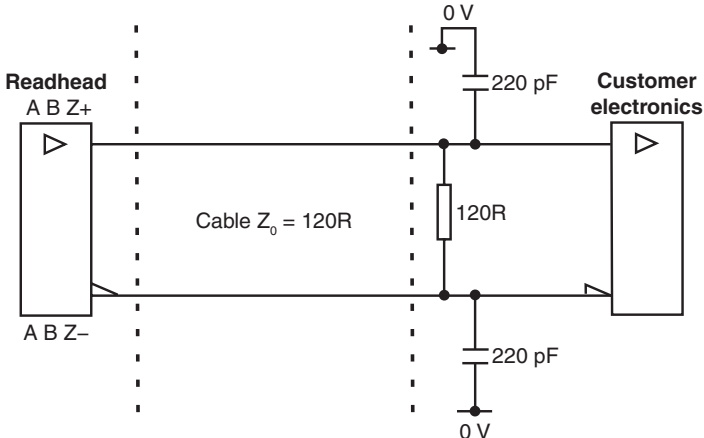

Standard RS422A line receiver circuitry.
The capacitors are recommended for improved noise immunity.

Single-ended alarm signal termination

(Not available with 'A' cable termination)

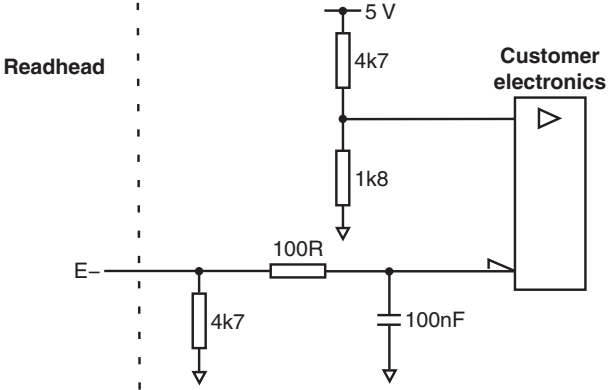

Remote CAL operation

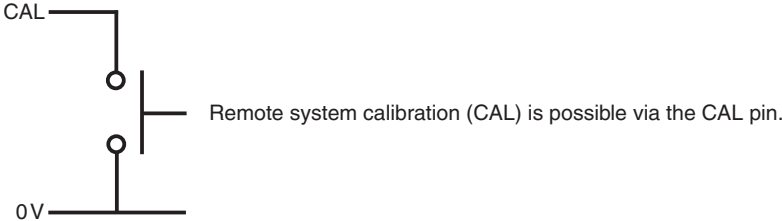

Output specifications

Digital output signals

Form – Square wave differential line driver to EIA RS422A

Incremental ¹

2 channels A and B in quadrature (90° phase shifted)

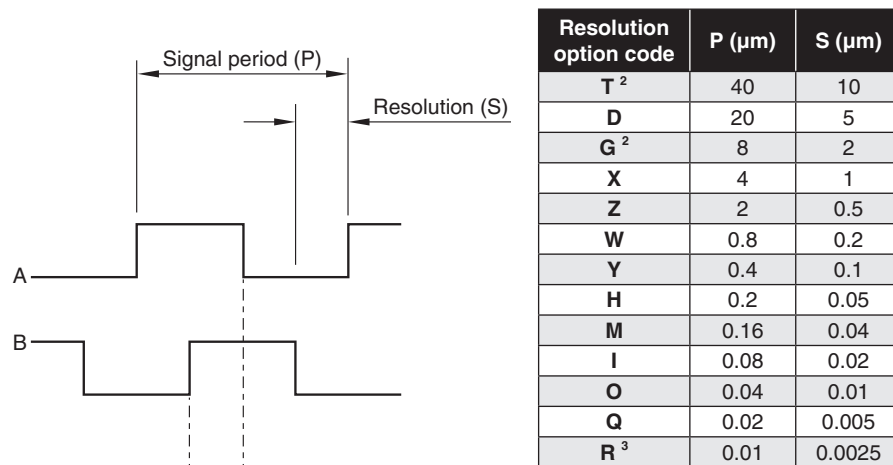

Reference ¹

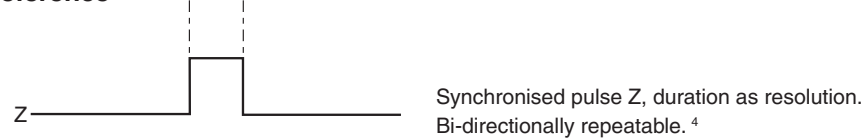

¹ For clarity, the inverse signals are not shown.

² 40 μm ATOM DX readheads only.

³ 20 μm ATOM DX readheads only.

⁴ Only the calibrated reference mark is bi-directionally repeatable.

Alarm

Line driven (Asynchronous pulse)
(Not available with 'A' cable termination)

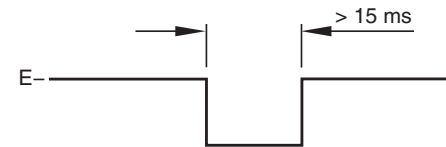

Alarm asserted when:

- The signal amplitude is < 20% or > 135%
- The readhead speed is too high for reliable operation

or 3-state alarm

Differentially transmitted signals forced open circuit for > 15 ms when alarm conditions valid.

General specifications

Power supply	5 V –5%/+10%	Typically < 200 mA fully terminated Power from a 5 Vdc supply complying with the requirements for SELV of standard IEC 60950-1
	Ripple	200 mVpp maximum @frequency up to 500 kHz
Temperature	Storage	–20 °C to +70 °C
	Operating	0 °C to +70 °C
Humidity		95% relative humidity (non-condensing) to IEC 60068-2-78
Sealing		IP40
Acceleration (system)	Operating	400 m/s ² , 3 axes
Shock (system)	Operating	1000 m/s ² , 11 ms, ½ sine, 3 axes
Vibration	Operating	100 m/s ² max @ 55 Hz to 2000 Hz, 3 axes
Mass	Cabled readhead	3.2 g
	Top exit readhead	2.9 g
	Cable	18 g/m
Cable	Cabled readhead	10 core, high flex, EMI screened cable, outside diameter 3.5 mm maximum Flex life > 20 × 10 ⁶ cycles at 20 mm bend radius, maximum length 3 m (Extension cable up to 25 m when using Renishaw approved extension cable) UL recognised component 
	Top exit readhead	Cables available in lengths from 0.5 m to 3 m with 15-way D-type or 10-way JST (SH) connector options
Connector options	Cabled readhead	9-way D-type 15-way D-type (standard and alternative pin out) 10-way JST (SH)
	Top exit readhead	10-way JST (SUR)
Typical sub-divisional error (SDE)	20 µm version	< ±75 nm
	40 µm version	< ±120 nm

CAUTION: Renishaw encoder systems have been designed to the relevant EMC standards, but must be correctly integrated to achieve EMC compliance. In particular, attention to shielding arrangements is essential.

RKLF scale specifications

Material		Hardened and tempered martensitic stainless steel fitted with a self-adhesive backing tape
Form (height x width)		0.15 mm x 6 mm (including adhesive)
Pitch		20 µm or 40 µm
Reference mark	Positioning	Auto-phase optical reference mark repeatable to the unit of resolution throughout the specified speed and temperature range Customer deselectable reference marks at 50 mm spacing ¹ Reference mark in the centre for lengths < 100 mm
Accuracy (at 20 °C)	RKLF20-S/RKLF40H-S RKLF40-S	±5 µm/m ±15 µm/m
Linearity (at 20 °C)	RKLF20-S/RKLF40H-S RKLF40-S	±2.5 µm/m achievable with two-point error correction ±3 µm/m achievable with two-point error correction
Installation temperature ²		+10 °C to +35 °C
Coefficient of thermal expansion (at 20 °C)		Matches that of the substrate material when the scale ends are fixed with the epoxy mounted end clamps
Length		20 mm to 1 m in 10 mm increments 1 m to 10 m in 1 m increments ³ Overall length = measuring length + 70 mm Scale length = measuring length + 40 mm
Mass		4.6 g/m
End fixing		Epoxy mounted end clamps (A-9523-4015) RGG-2 two part epoxy adhesive (A-9531-0342) Scale end movement typically < 1 µm ⁴

¹ Only the selected reference mark is bi-directionally repeatable.



² The scale and the end clamps must be installed following the installation process detailed in this guide (see page 16 and page 18).

³ The recommended maximum axis length for 20 µm systems is 1 m.

⁴ To limit the maximum tension in the scale $(CTE_{\text{substrate}} - CTE_{\text{scale}}) \times (T_{\text{use extreme}} - T_{\text{install}}) \leq 550 \mu\text{m/m}$ where $CTE_{\text{scale}} = \sim 10.1 \mu\text{m/m}^\circ\text{C}$.

www.renishaw.com/contact

 #renishaw

 +44 (0) 1453 524524  uk@renishaw.com

© 2017-2024 Renishaw plc. All rights reserved. This document may not be copied or reproduced in whole or in part, or transferred to any other media or language by any means, without the prior written permission of Renishaw.
RENISHAW® and the probe symbol are registered trade marks of Renishaw plc. Renishaw product names, designations and the mark 'apply innovation' are trade marks of Renishaw plc or its subsidiaries. Other brand, product or company names are trade marks of their respective owners.
Renishaw plc. Registered in England and Wales. Company no: 1106260. Registered office: New Mills, Wotton-under-Edge, Glos, GL12 8JR, UK.

WHILE CONSIDERABLE EFFORT WAS MADE TO VERIFY THE ACCURACY OF THIS DOCUMENT AT PUBLICATION, ALL WARRANTIES, CONDITIONS, REPRESENTATIONS AND LIABILITY, HOWSOEVER ARISING, ARE EXCLUDED TO THE EXTENT PERMITTED BY LAW. RENISHAW RESERVES THE RIGHT TO MAKE CHANGES TO THIS DOCUMENT AND TO THE EQUIPMENT, AND/OR SOFTWARE AND THE SPECIFICATION DESCRIBED HEREIN WITHOUT OBLIGATION TO PROVIDE NOTICE OF SUCH CHANGES.

Part no.: M-9414-9906-01-A
Issued: 07.2024