

FORTiS-S™ enclosed encoder system



This page is left intentionally blank.

Contents

1	Legal notices	5
1.1	Patents	5
1.2	Terms and Conditions and Warranty	5
1.3	Declaration of Conformity	5
1.4	Federal Code Of Regulation (CFR) FCC Part 15 – RADIO FREQUENCY DEVICES	5
1.5	Intended use	6
1.6	Warnings	6
1.7	Packaging	6
1.8	REACH regulation	6
1.9	Disposal of waste electrical and electronic equipment	6
2	Overview of the FORTiS encoder system	7
2.1	Commissioning test	7
2.2	Maintenance	7
2.3	Repair	7
2.4	Further information	8
3	Parts list	9
3.1	Included in the box	9
3.2	Not included / required tools	10
3.3	Optional extras	11
3.4	Cable options	11
4	Storage and handling	12
5	Installation drawings	13
5.1	Mounting surface preparation	13
5.2	Location edge or dowel pins	13
5.3	Mounting orientations	14

5.4	FORTiS system installation drawings15
5.5	Mounting holes positions table16
6	Product specification18
7	Installation procedure – extrusion20
7.1	Protection for sealed linear encoders20
7.2	Fitment – general21
8	Installation procedure – readhead22
8.1	Measuring length22
8.2	Alignment bracket method22
8.3	Set-up shim method24
8.4	Installation using the mounting aid method26
8.5	FORTiS cable connection28
8.6	Validating an installation.29
8.7	Air supply30
9	Electrical connections31
9.1	Electrical preparation31
9.2	FORTiS grounding and shielding31
10	Cables and serial interfaces32
10.1	General specifications32
10.2	Permissible cable lengths.32
10.3	BiSS C serial interface35
10.4	FANUC serial interface.36
10.5	Mitsubishi serial interface.38
10.6	Panasonic serial interface39
10.7	Siemens serial interface.40
10.8	Yaskawa serial interface.43

1 Legal notices

1.1 Patents

Features of Renishaw’s encoder systems and similar products are the subjects of the following patents and patent applications:

CN1260551	US7499827	JP4008356	GB2395005	US20100163536
US20150225858	CN102197282	EP2350570	JP5480284	US8505210
KR1630471	CN102388295	EP2417423	KR1701535	US2012007980
CN102460077	EP2438402	US20120072169	KR1851015	JP6074392
JP5755223	EP01103791	US6465773		

1.2 Terms and Conditions and Warranty

Unless you and Renishaw have agreed and signed a separate written agreement, the equipment and/or software are sold subject to the Renishaw Standard Terms and Conditions supplied with such equipment and/or software, or available on request from your local Renishaw office.

Renishaw warrants its equipment and software for a limited period (as set out in the Standard Terms and Conditions), provided that they are installed and used exactly as defined in associated Renishaw documentation. You should consult these Standard Terms and Conditions to find out the full details of your warranty.

Equipment and/or software purchased by you from a third-party supplier is subject to separate terms and conditions supplied with such equipment and/or software. You should contact your third-party supplier for details.

1.3 Declaration of Conformity

Renishaw plc hereby declares that the FORTiS-S™ encoder system is in compliance with the essential requirements and other relevant provisions of:

- the applicable EU directives
- the relevant statutory instruments under UK law.



The full text of the Declaration of Conformity is available at: www.renishaw.com/productcompliance

1.4 Federal Code Of Regulation (CFR) FCC Part 15 – RADIO FREQUENCY DEVICES

FCC Compliance Statement

47 CFR Section 15.19

This device complies with part 15 of the FCC Rules. Operation is subject to the following two conditions:

1. This device may not cause harmful interference, and
2. This device must accept any interference received, including interference that may cause undesired operation.

47 CFR Section 15.21

The user is cautioned that any changes or modifications not expressly approved by Renishaw plc or authorised representative could void the user’s authority to operate the equipment.

47 CFR Section 15.105

This equipment has been tested and found to comply with the limits for a Class A digital device, pursuant to part 15 of the FCC Rules. These limits are designed to provide reasonable protection against harmful interference when the equipment is operated in a commercial environment. This equipment generates, uses, and can radiate radio frequency energy and, if not installed and used in accordance with the instruction manual, may cause harmful interference to radio communications. Operation of this equipment in a residential area is likely to cause harmful interference in which case the user will be required to correct the interference at their own expense.

47 CFR Section 15.27

This unit was tested with shielded cables on the peripheral devices. Shielded cables must be used with the unit to ensure compliance.

Supplier's Declaration of Conformity

47 CFR § 2.1077

Unique Identifier: FORTiS-S

Responsible Party – U.S. Contact Information

Renishaw Inc.
1001 Wesemann Drive
West Dundee
Illinois
IL 60118
United States
Telephone number: +1 847 286 9953
Email: usa@renishaw.com

ICES-003 – Information Technology Equipment (including Digital Apparatus)

This ISM device complies with Canadian ICES-003(A).
Cet appareil ISM est conforme à la norme ICES-003(A).

1.5 Intended use

The FORTiS encoder system is designed for metrology in industrial environments, such as machine tools. It must be installed, operated, and maintained as specified in Renishaw documentation and in accordance to the Standard Terms and Conditions of the Warranty and all other relevant legal requirements.

1.6 Warnings

In all applications involving the use of machine tools, eye protection is recommended.

1.7 Packaging

The packaging of our products contains the following materials and can be recycled.

Packaging components			
Packaging component	Material	ISO 11469	Recycling guidance
Wooden box	Plywood and softwood	Not applicable	Recyclable
Outer box	Cardboard	Not applicable	Recyclable
	Polypropylene	PP	Recyclable
Inserts	Low density polyethylene foam	LDPE	Recyclable
	Cardboard	Not applicable	Recyclable
Bags	High density polyethylene bag	HDPE	Recyclable
	Metalised polyethylene	PE	Recyclable

1.8 REACH regulation

Information required by Article 33(1) of Regulation (EC) No. 1907/2006 ("REACH") relating to products containing substances of very high concern (SVHCs) is available at:

www.renishaw.com/REACH

1.9 Disposal of waste electrical and electronic equipment



The use of this symbol on Renishaw products and/or accompanying documentation indicates that the product should not be mixed with general household waste upon disposal. It is the responsibility of the end user to dispose of this product at a designated collection point for waste electrical and electronic equipment (WEEE) to enable reuse or recycling. Correct disposal of this product will help to save valuable resources and prevent potential negative effects on the environment. For more information, contact your local waste disposal service or Renishaw distributor.

2 Overview of the FORTiS encoder system

This system is an enclosed linear optical encoder designed for use in harsh industrial environments where high-precision feedback and metrology are required. Based upon Renishaw's award-winning absolute technology, the rugged non-contact design has no internal moving parts, such as bearings or wheeled readhead carriages, thus improving the overall reliability. Additionally, hysteresis and backlash errors associated with mechanical contact system designs are reduced.

In addition to enhanced breakage resistance, the robust steel scale has a coefficient of thermal expansion similar to the base material used in the majority of machines, reducing errors due to thermal effects whilst increasing measurement certainty.

Renishaw's patented set-up LED provides instant verification of the encoder's signal strength and therefore its accurate alignment. This intuitive procedure eliminates the need for additional peripheral diagnostics equipment during installation. When combined with Renishaw's carefully designed installation accessories, these unique tools make installation easier and faster compared to traditional methods, whilst building confidence in a right-first-time installation.

2.1 Commissioning test

Relevant commissioning tests should be carried out in accordance with the installer/user's normal procedure.

The following test **MUST** be performed when commissioning the FORTiS-S encoder system and after any repair or maintenance of the system.

Resolution check: Move the axis by a known distance and confirm that the position changes as expected.

2.2 Maintenance

The maintenance check intervals will be defined by the system manufacturer according to their risk assessment. There are no user-serviceable parts within the FORTiS-S encoder system.

The following maintenance actions are advised:

- Check the extrusion screws and readhead retaining screws are correctly tightened.
- Check for worn or damaged cables and connectors.
- Check the cable connectors are correctly tightened/located.
- Check the air supply fitting is correctly tightened and the air hose is correctly fitted.
- When the DRIVE-CLiQ interface is used check the retaining screws are correctly tightened.

2.3 Repair

- Repair of the FORTiS-S encoder system is only by replacement of parts.
- The replacement parts must have the same part number as the original parts.
- The repaired encoder system must be installed and commissioned in accordance with the "Commissioning test" above.
- In the event of failure the affected parts should be returned to Renishaw for further analysis.
- Using damaged parts invalidates the warranty.

2.4 Further information

Further information relating to the FORTiS encoder range can be found in the FORTiS data sheets available from your local Renishaw representative or from our website:

www.renishaw.com/fortisdownloads







See also the data sheets *Cables for FORTiS absolute encoders* (Renishaw part no. L-9517-0069) and *BiSS C-mode (unidirectional) for RESOLUTE and FORTiS encoders* (Renishaw part no. L-9709-9005).

For further details regarding FORTiS enclosed linear encoder variants refer to the following table.







Encoder system description	Part numbers	
	Data sheet	Installation guide
FORTiS-S	L-9517-9934	M-9768-9857
FORTiS-S enclosed encoder system with multiple readheads	Refer to installation guide	M-6725-9176
FORTiS-S functional safety (FS) system	L-9517-9958	M-6725-9016
FORTiS-S functional safety (FS) system with multiple readheads	Refer to installation guide	M-6725-9188
FORTiS-N	L-9517-9946	M-9768-9887
FORTiS-N enclosed encoder system with multiple readheads	Refer to installation guide	M-6725-9200
FORTiS-N functional safety (FS) system	L-9517-9970	M-6725-9026
FORTiS-N functional safety (FS) system with multiple readheads	Refer to installation guide	M-6725-9212

3 Parts list

3.1 Included in the box

Item		Description
	FORTiS-S encoder unit	The FORTiS-S enclosed encoder system
	37 mm readhead setting shim	Plastic shim to be used as an installation aid
	Air connection fitting	To enable connection to one of the encoder air purge inlets
	Cable connection wrench	Used for securely connecting the encoder cable to the readhead
	Alignment brackets	Two brackets to secure the readhead during transit and set the correct readhead alignment during installation <hr/> IMPORTANT: Retain until installation is complete. <hr/>
	FORTiS quality inspection certificate	Certifies specific encoder performance and provides traceability
	Siemens DRIVE-CLiQ interface	Included with Siemens-only versions of FORTiS (see section 10.7 on page 40)

3.2 Not included / required tools

Item		Description
	5 mm torque wrench	To tighten the extrusion and the readhead mounting screws
	1.5 mm hex key	Air bung removal (only if air purge is required)
	4 mm hex key	For locking the mounting aid For use with the M5 extrusion and M5 readhead screw options
	5 mm hex key	For use with the M6 extrusion and M6 readhead screw options
	M6 screws	2 × M6 × 1.0 screws length ≥ 35 mm for mounting readhead M6 × 1.0 screws length ≥ 20 mm for mounting the extrusion to the machine bed (see table in section 5.5 on page 16 for required quantity)
	Loctite 243	All fastenings (except air bung and cable connection) should be secured with Loctite 243
	Loctite 222	If an air bung requires replacement or repositioning it should be secured with Loctite 222. The cable connector should also be secured with Loctite 222.

3.3 Optional extras

3.3.1 Mounting aid (Renishaw part no. A-9768-3580)

Optional installation aid to assist with mounting the readhead to a machine slideway that has more than one degree of freedom (see [section 8.4](#) on page 26).







3.3.2 Captive nuts (Renishaw part no. A-9768-2248)

Optional fastening method for mounting the readhead to the bracket. It allows bolts to be screwed into the readhead rather than the bracket.



3.4 Cable options (cables not included)

Further information relating to cables for the FORTiS encoder range can be found in the data sheet *Cables for FORTiS absolute encoders* (Renishaw part no. L-9517-0069). This can be downloaded from our website www.renishaw.com/fortisdownloads and is also available from your local Renishaw representative.

Item		Description
	Encoder cable type A	OD: 4.7 mm, 28 AWG, 7 core, single screen, black jacket Length options: 0.5 m, 1 m, 3 m, 6 m, 9 m
	Encoder cable type B	OD: 6.3 mm, 23 AWG, 6 core (3 × twisted pairs), single screen, green jacket Length options: 0.5 m, 1 m, 3 m, 6 m, 9 m
	Encoder cable type D	Armoured: OD 10 mm, 28 AWG, 7 core Length options: 1 m, 3 m, 6 m, 9 m
	Extension cable type B	OD: 6.3 mm, 23 AWG, 6 core (3 × twisted pairs), single screen, green jacket Length options: 1 m, 3 m, 6 m, 9 m, 15 m, 20 m
	Extension cable type C	OD: 7.8 mm, 2 × 20 AWG (power), 4 × 23 AWG (signal), 2 × 28 AWG (sense), single screen, green jacket Unterminated lengths available up to 100 m

3.4.1 FORTiS connector

All encoder cables include a custom FORTiS connector that connects to the readhead. The connector is covered with a protective cap with an integrated clip; this clip can be used to assist with cable routing.



4 Storage and handling

IMPORTANT: Handle carefully to avoid damage to the location faces when unpacking and installing.

Storage temperature

-20 °C to +70 °C



Operating temperature

0 °C to +50 °C



95% relative humidity (non-condensing)
to IEC 60068-2-78



Handling instructions

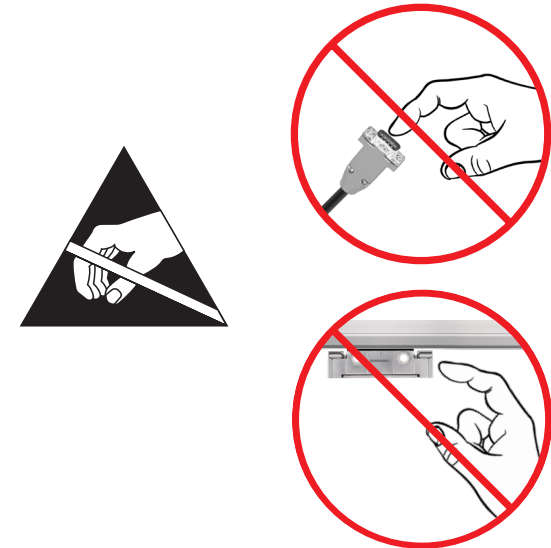
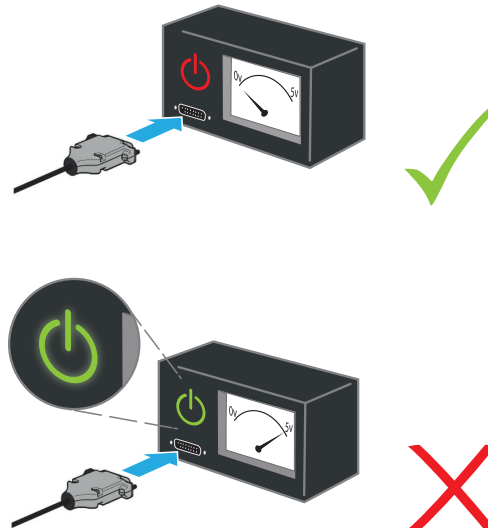

5 Installation drawings

5.1 Mounting surface preparation

To ensure correct operation, the mounting surface should be prepared as follows:

- surface flatness requirement of 0.05 mm/m
- surface should be free of paint and burrs
- refer to installation drawing for required mounting hole positions (see [section 5.4](#) on page 15).

To further simplify and help reduce installation time, it is recommended that the machine axis to which the encoder is to be mounted is prepared with a datum edge or aligned dowel pins to help locate the edge of the extrusion and ensure parallelism to the axis of motion.

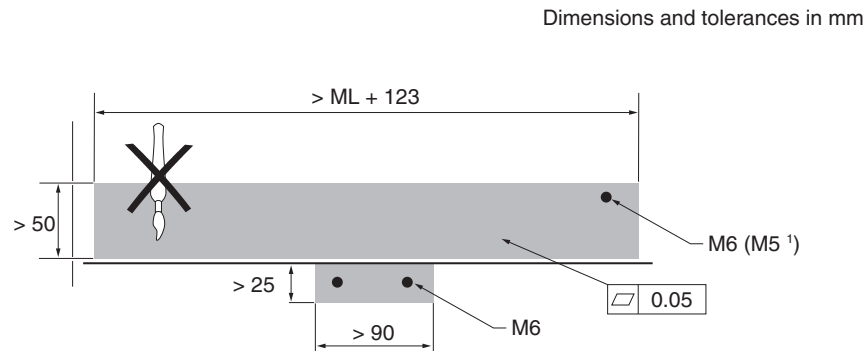

¹ Permissible alternative screw size.

5.2 Location edge or dowel pins

Dimensions and tolerances in mm

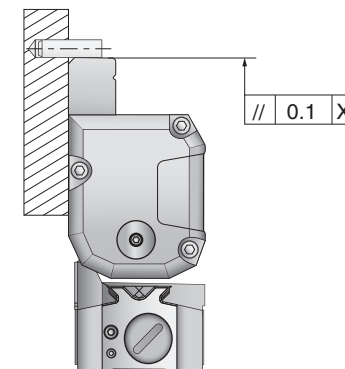
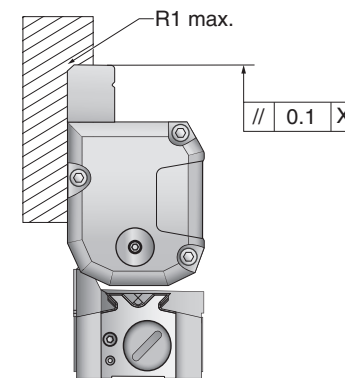

5.3 Mounting orientations

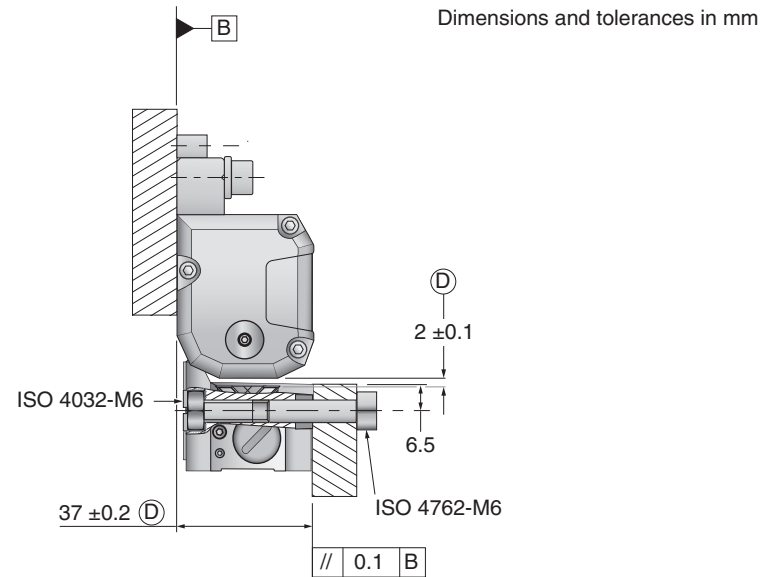
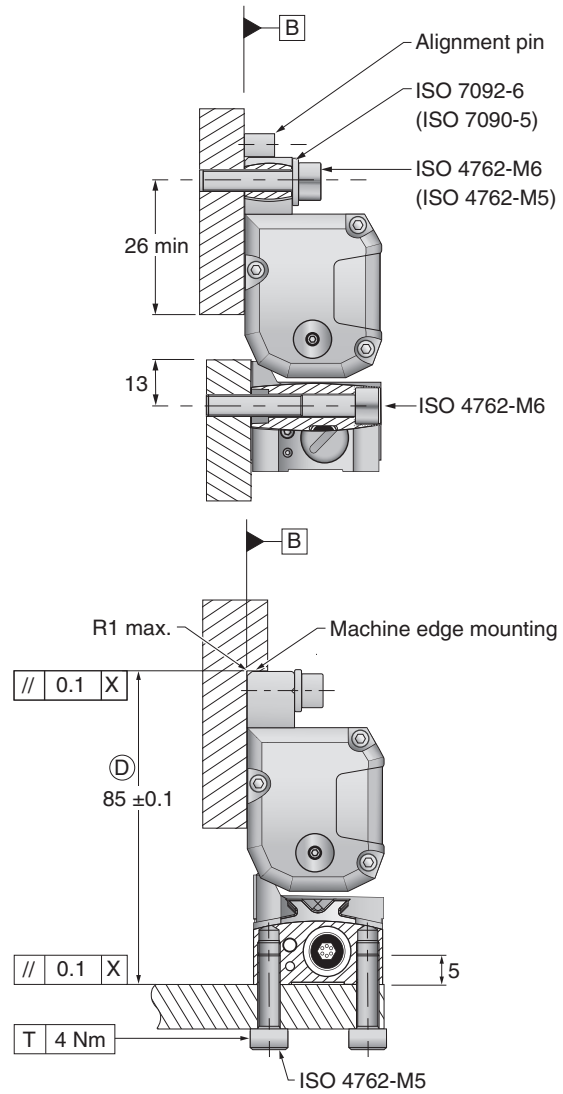

KEY

D = Required mounting dimensions

X = Machine guideway/axis datum

NOTES:

1. Side elevations show alternative mounting orientations.
2. Screws sizes in brackets are permissible alternatives.

5.4 FORTiS system installation drawings

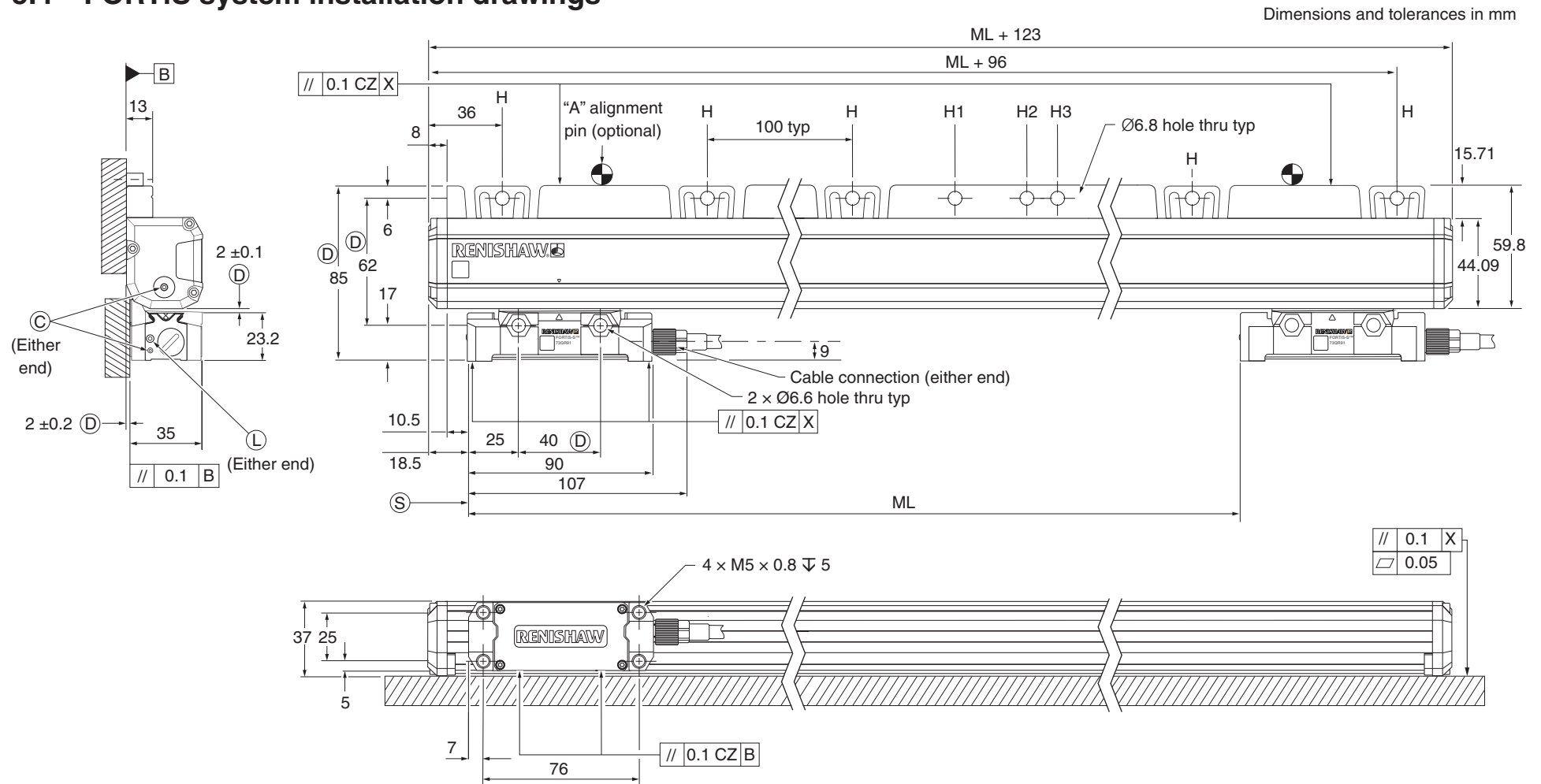

KEY

A = Recommended extrusion alignment pin locations (if required)

Adjacent to first and last flexure holes plus every 300–500 mm

C = Compressed air inlet fitting

D = Required mounting dimensions

H = Flexure mounting holes

H1 = Fixed mounting hole (preferred)

H2 and H3 = Alternative mounting holes (non-preferred)

L = LED set-up illumination

ML = Measuring length

S = Start of measuring length

X = Machine guideway/axis datum

5.5 Mounting holes positions table

Measuring length	Overall length	Recommended thermal datum	Non-preferred thermal datum ¹			Flexure holes, H every 100 mm			
		Static hole H1	Static hole H2	Static hole H3	First flexure hole	Missing flexure hole	Last flexure hole	QTY of flexure holes	
140	263	136	171	-	36	136	236	2	
240	363	186	221	236	36	236	336	3	
340	463	236	271	-	36	236	436	4	
440 (shown)	563	286	321	336	36	336	536	5	
540	663	336	371	-	36	336	636	6	
640	763	386	421	436	36	436	736	7	
740	863	436	471	-	36	436	836	8	
840	963	486	521	536	36	536	936	9	
940	1063	536	571	-	36	536	1036	10	
1040	1163	586	621	636	36	636	1136	11	
1140	1263	636	671	-	36	636	1236	12	
1240	1363	686	721	736	36	736	1336	13	
1340	1463	736	771	-	36	736	1436	14	
1440	1563	786	821	836	36	836	1536	15	
1540	1663	836	871	-	36	836	1636	16	
1640	1763	886	921	936	36	936	1736	17	
1740	1863	936	971	-	36	936	1836	18	
1840	1963	986	1021	1036	36	1036	1936	19	
2040	2163	1086	1121	1136	36	1136	2136	21	
2240	2363	1186	1221	1236	36	1236	2336	23	
2440	2563	1286	1321	1336	36	1336	2536	25	
2640	2763	1386	1421	1436	36	1436	2736	27	
2840	2963	1486	1521	1536	36	1536	2936	29	
3040	3163	1586	1621	1636	36	1636	3136	31	

¹ The non-preferred thermal datum holes are only included to provide bolt-hole compatibility with old, obsolete encoders. New machines should be designed to use the recommended thermal datum only.

Mounting holes positions table (continued)

Measuring length	Overall length	Recommended thermal datum	Non-preferred thermal datum ¹			Flexure holes, H every 100 mm			
		Static hole H1	Static hole H2	Static hole H3	First flexure hole	Missing flexure hole	Last flexure hole	QTY of flexure holes	
3240	3363	1686	1721	1736	36	1736	3336	33	
3440	3563	1786	1821	1836	36	1836	3536	35	
3640	3763	1886	1921	1936	36	1936	3736	37	
3840	3963	1986	2021	2036	36	2036	3936	39	
4040	4163	2086	2121	2136	36	2136	4136	41	
4240	4363	2186	2221	2236	36	2236	4336	43	

¹ The non-preferred thermal datum holes are only included to provide bolt-hole compatibility with old, obsolete encoders. New machines should be designed to use the recommended thermal datum only.

6 Product specification

Measuring standard	Renishaw stainless-steel scale with single track absolute encoding
Coefficient of thermal expansion (at 20 °C)	10.1 ±0.2 µm/m/°C
Thermal datum	At centre position (encoder position of 0.5 × measuring length)
Measuring lengths available (mm)	140, 240, 340, 440, 540, 640, 740, 840, 940, 1040, 1140, 1240, 1340, 1440, 1540, 1640, 1740, 1840, 2040, 2240, 2440, 2640, 2840, 3040, 3240, 3440, 3640, 3840, 4040, 4240
Accuracy grades	High grade: ≤ ±3 µm (available in lengths up to 3040 mm only) Standard grade: ≤ ±5 µm
Resolution ¹	0.5 nm, 1 nm, 1.25 nm, 10 nm, 12.5 nm, 25 nm, 50 nm
Sub-Divisional Error (typical)	±40 nm
Jitter (RMS)	10 nm
Absolute position serial interface	BiSS C, FANUC (α/α_i), Mitsubishi, Panasonic, Siemens DRIVE-CLiQ (with external interface), Yaskawa
Encoder electrical connection	Cable connector M12 custom (customer configurable exit direction)
Controller electrical connection	8-way M12, FANUC 20-way, 10-way Mitsubishi, 17-way M23, 9-way D-Type, 14-way LEMO, flying lead
Cable length	Up to 100 m (with extension cable)
Power supply ²	5 V ±10% 1.25 W maximum (250 mA @ 5 V) Ripple 200 mVpp maximum @ frequency up to 500 kHz

¹ See tables on page 19 for relevant accuracy grade and serial interface.

² Current consumption figures refer to terminated FORTiS systems. Renishaw encoder systems must be powered from a 5 Vdc supply complying with the requirements for SELV of standard IEC 60950-1.

Set-up LED	Signal strength indicator LED colour: Excellent: BLUE Good: GREEN Satisfactory: ORANGE Poor: RED No signal: Flashing RED
Maximum speed	4 m/s
Acceleration (readhead relative to scale)	< 200 m/s ² in measuring direction
Moving force (maximum force required to move the readhead through the seals)	< 5 N
Vibration (55 Hz to 2 000 Hz)	Housing: < 300 m/s ² to IEC 60068-2-6 Readhead: < 300 m/s ² to IEC 60068-2-6
Shock 11 ms half-sine	< 300 m/s ² IEC 60068-2-27
Operating temperature	0 °C to 50 °C
Environment protection	IP53 when installed correctly, IP64 with air purge
Air purge requirements	Air supply pressure = 1 bar at encoder At correct supply pressure the supplied air connection fitting restricts the air flow rate to 2 l/min Air quality: see section 8.7 on page 30 for details
Weight	0.27 kg + 2.0 kg/m

IMPORTANT: Specifications are subject to the correct installation procedures as set out in this installation guide. If in doubt, contact your local Renishaw representative.

Product specification (continued)

Resolution per accuracy grade and serial interface – standard options

Accuracy grade	Serial interface	Resolution (nm)	
		Single	Dual
3 µm	BiSS C, Mitsubishi, Panasonic, Siemens DRIVE-CLiQ, Yaskawa	1	
	FANUC		1 / 0.5
			10 / 1.25
5 µm	BiSS C, Mitsubishi, Panasonic, Siemens DRIVE-CLiQ, Yaskawa	10	
		50	
	FANUC		50 / 12.5
			50 / 25

NOTE: For BiSS C encoders, the standard position word length is 36 bits long. However, to accommodate controllers that require a shorter position word length, versions with 26 bit or 32 bit word length are also available (with standard 5 µm accuracy grade only).

Position word length	Nomenclature code	Accuracy grade	Resolution options (nm)		
			1	10	50
36 bit	36B	3 µm	OK	N/A	N/A
		5 µm	N/A	OK	OK
32 bit	32B		N/A	OK	N/A
26 bit	26B		N/A	N/A	OK

NOTE: For Siemens DRIVE-CLiQ encoders, the position word length is linked to the resolution, which in turn is linked to the accuracy grade. Here are the three options.

Position word length	Nomenclature code	Accuracy grade	Resolution options (nm)
34 bit	34D	3 µm	1
30 bit	30D	5 µm	10
28 bit	28D	5 µm	50

7 Installation procedure – extrusion

7.1 Protection for sealed linear encoders

IP53 requires installation with sealing lips positioned away from splash water in accordance with EN 60529/IEC 60529.

For ingress protection to IP64, please see [section 8.7](#) on page 30.

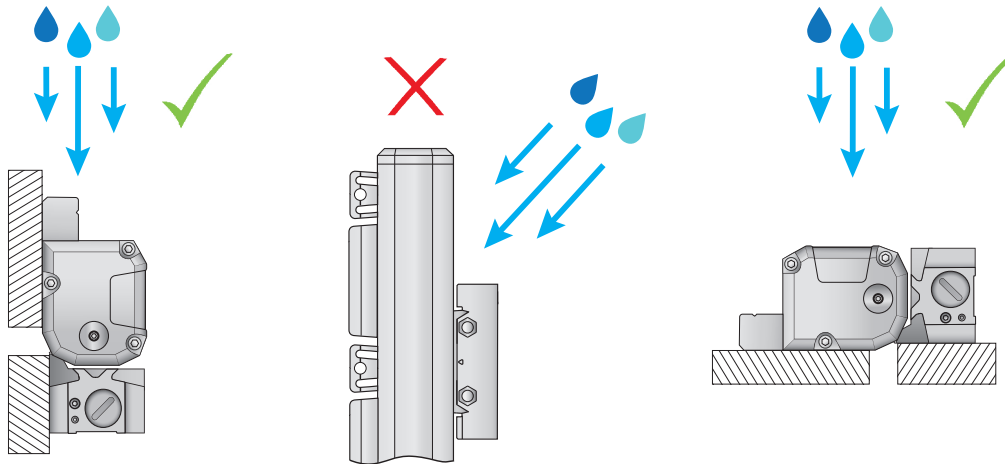

7.2 Fitment – general

Please note that fitment of the extrusion is independent of readhead mounting. For illustrative purposes dowel pins are displayed, but the procedure for a datum edge is identical. Where neither an edge or dowel pins are available, begin by aligning extrusion mounting holes.¹

Ensure the mounting faces are clean before installation.

¹ If a suitable reference edge or dowel pins are not available then we recommend that the extrusion is checked against a dial gauge to ensure parallelism to the machine axis.

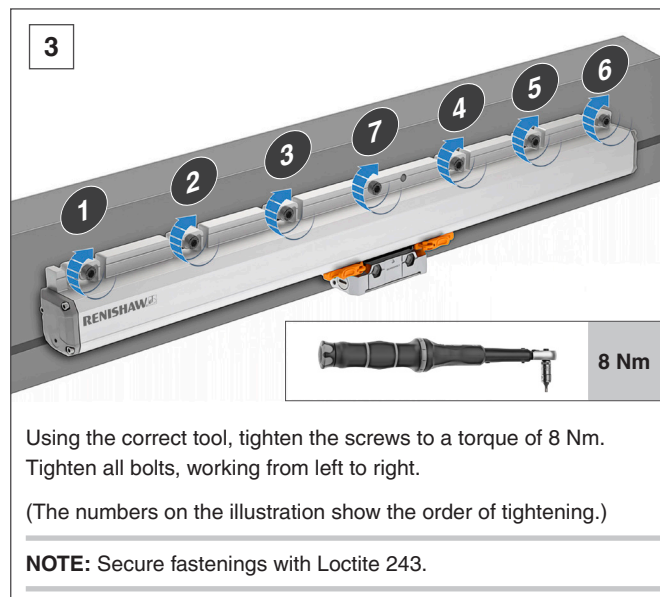
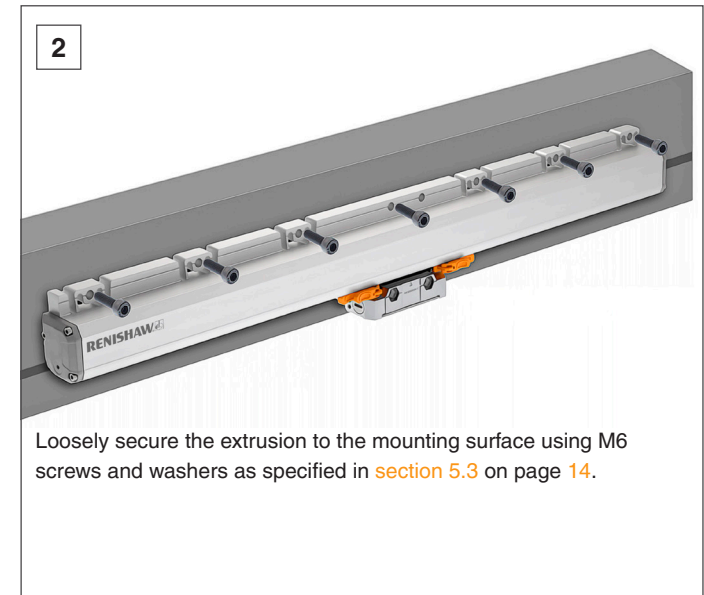
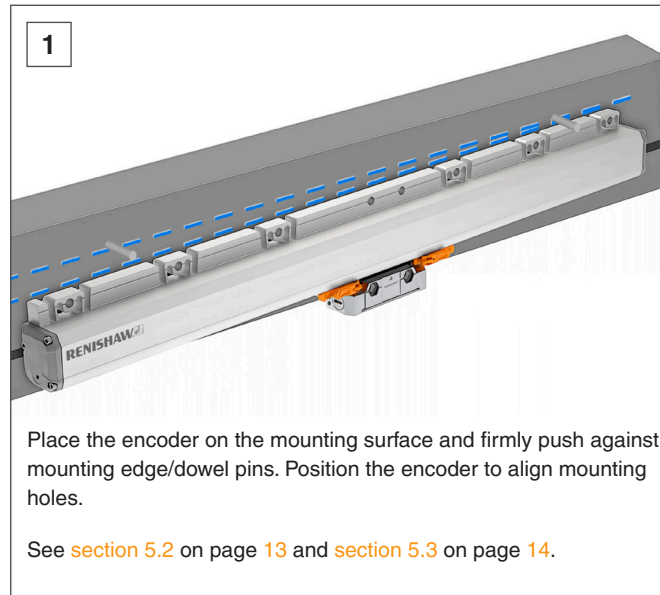

8 Installation procedure – readhead

Three different methods may be used to install the readhead, making installation easier for a wide range of machine types and mounting surfaces. These are outlined in the following sections.

NOTE: Installation of the extrusion follows the procedure outlined in [section 7](#) on page 20 and is independent of the readhead installation method being used.

8.1 Measuring length

The start of the measuring length (ML) is indicated by the triangular marking on the extrusion; a corresponding arrow on the readhead should be aligned to this arrow to ensure the readhead is within the encoder measuring length.

8.1.1 Start of measuring length

Dimensions and tolerances in mm

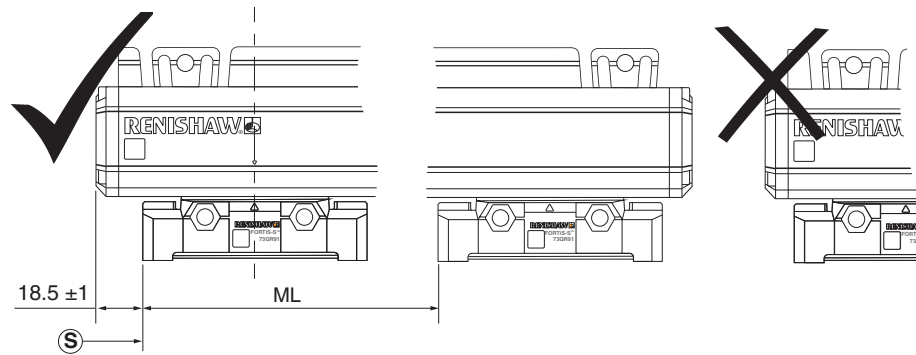

KEY

ML = Measuring length

S = Start of measuring length

WARNING: Failure to ensure the readhead is within the measuring length of the encoder could lead to a collision and damage.

8.2 Alignment bracket method

Pre-fitted alignment brackets help protect and secure the readhead to the extrusion during transit. These alignment brackets can also be used to set the readhead at the nominal installation rideheight.

The alignment brackets have three different operating positions which are detailed in the table below.

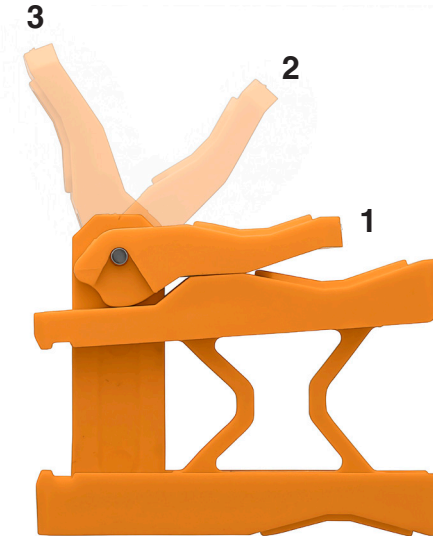

Position	Status	Description
1	Closed	Alignment bracket locks the readhead to the extrusion for transit
2	Semi-open	Readhead can be moved along the extrusion for alignment purposes, whilst maintaining optimum rideheight
3	Open	Alignment bracket can be removed from the extrusion after installation

8.2.1 Installation using the alignment bracket method

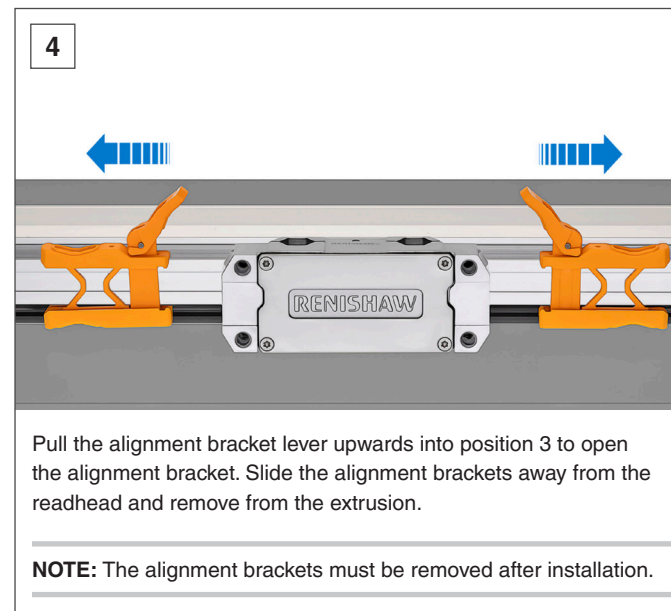
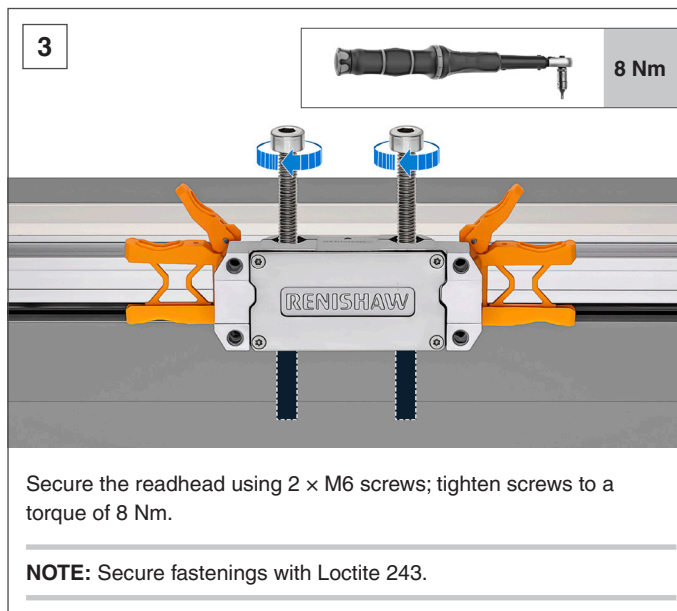
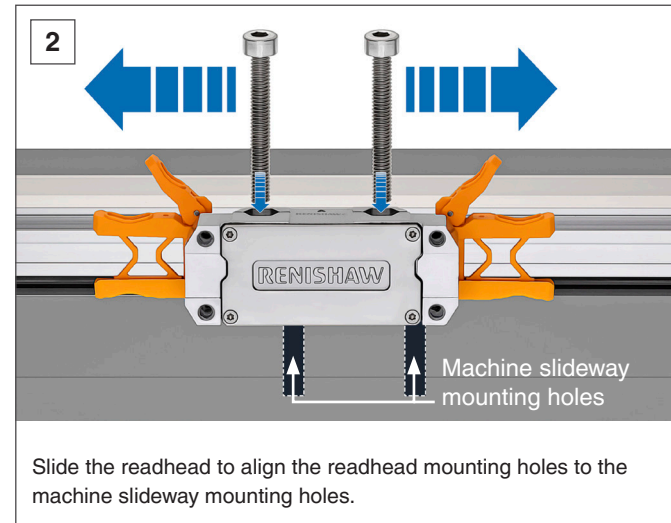
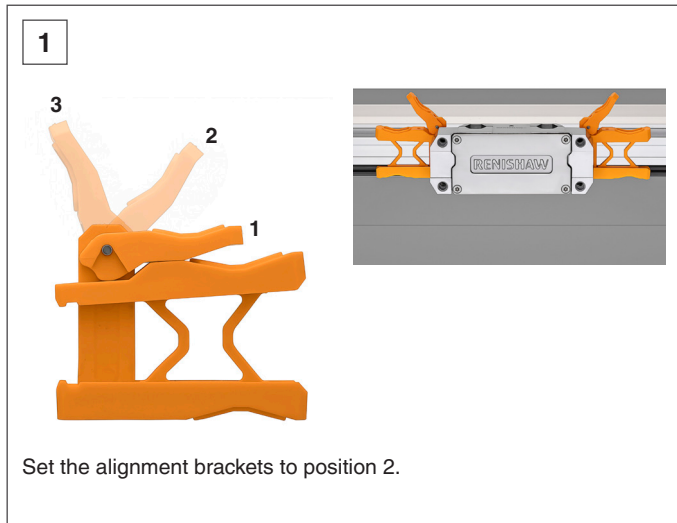

8.3 Set-up shim method

When using this method, remove the alignment brackets (see [section 8.2.1](#) on page 23) just prior to installation.

Where access to the readhead from either side is restricted in the installation position, a setting shim can be used instead of the alignment brackets to ensure correct positioning of the readhead relative to the extrusion. The shim is easily inserted between the readhead and encoder extrusion.

8.3.1 Front setting shim procedure

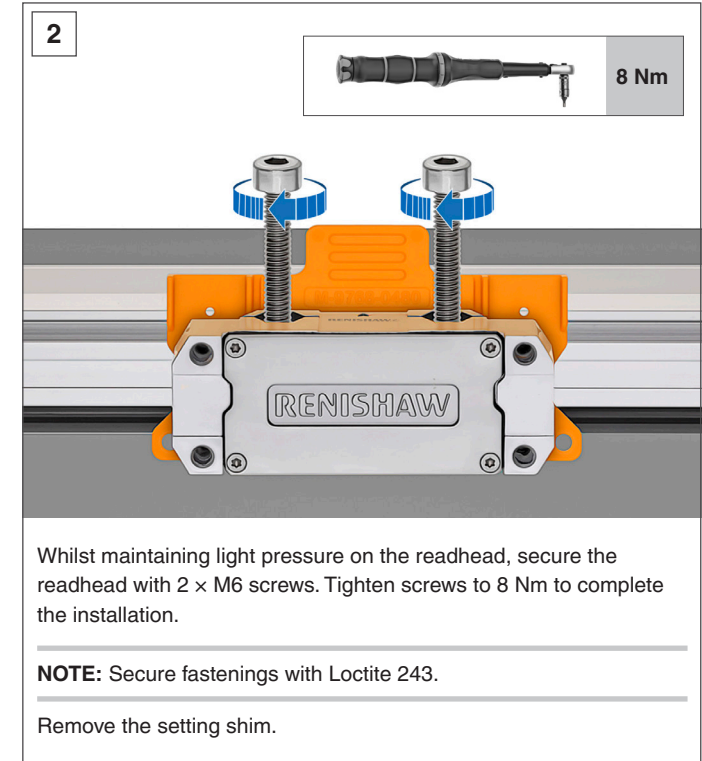
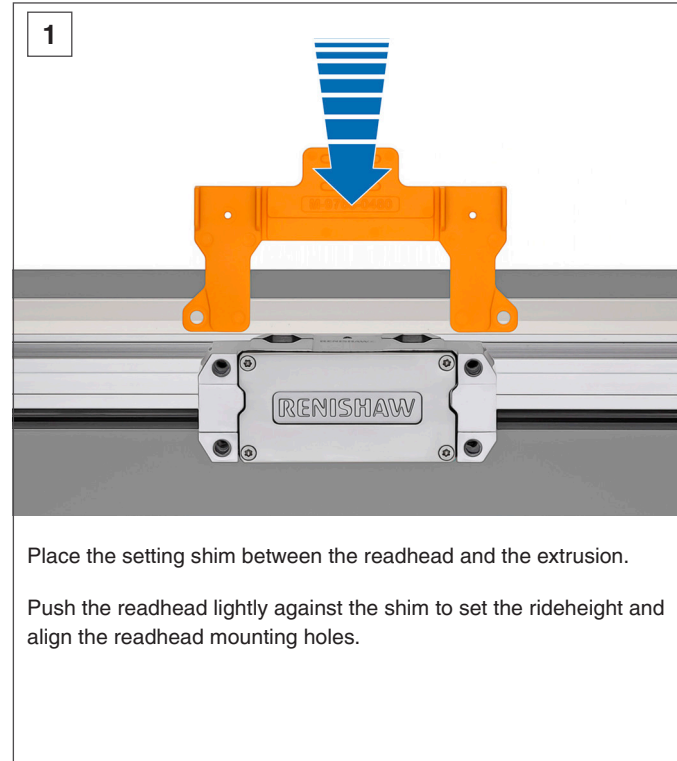

8.3.2 Side setting shim procedure

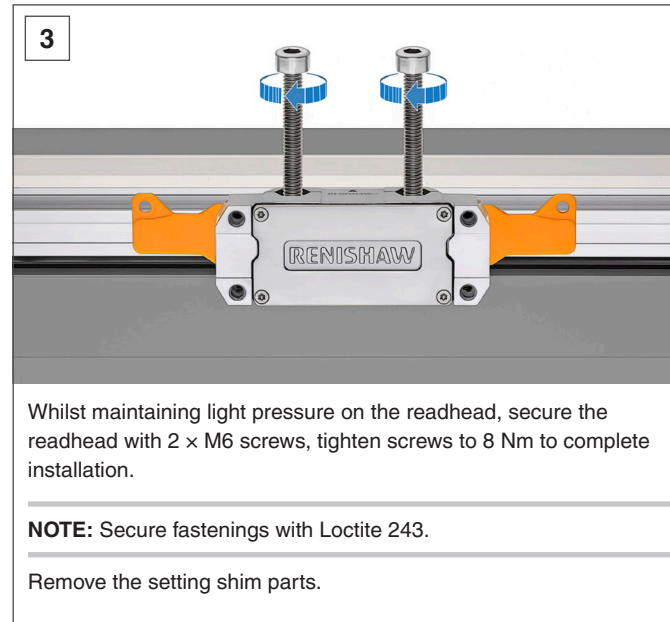
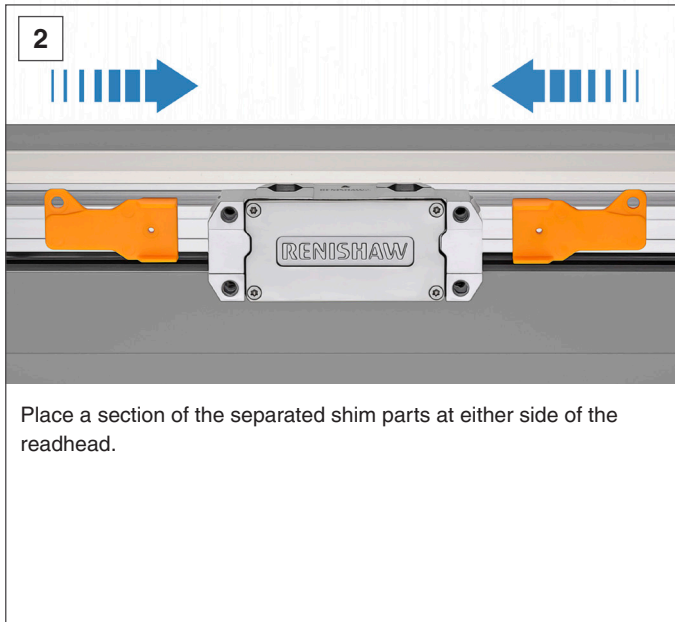
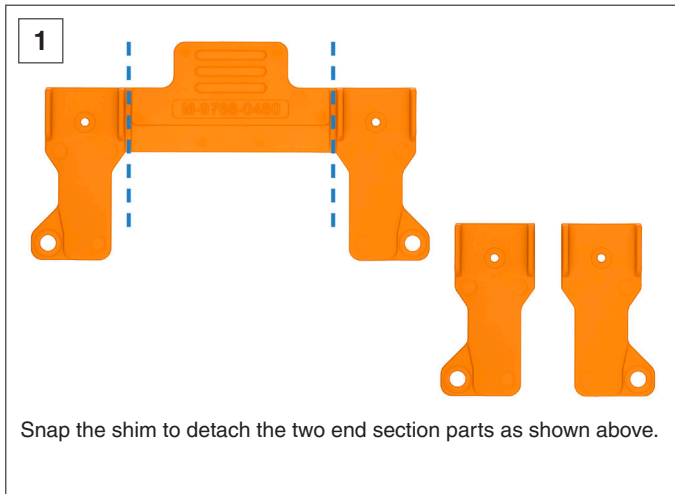

8.4 Installation using the mounting aid method

NOTE: 37 mm mounting aid and 4 mm hex key required.

Remove the alignment brackets prior to installation using the mounting aid.

When mounting a readhead to a machine slideway via an unconstrained bracket, an installation mounting aid can be used to accurately position, secure and fit the bracket to the slideway. The mounting aid clamps securely to the extrusion, allowing any machine slideway to be adjusted and secured horizontally in the correct location before readhead mounting.

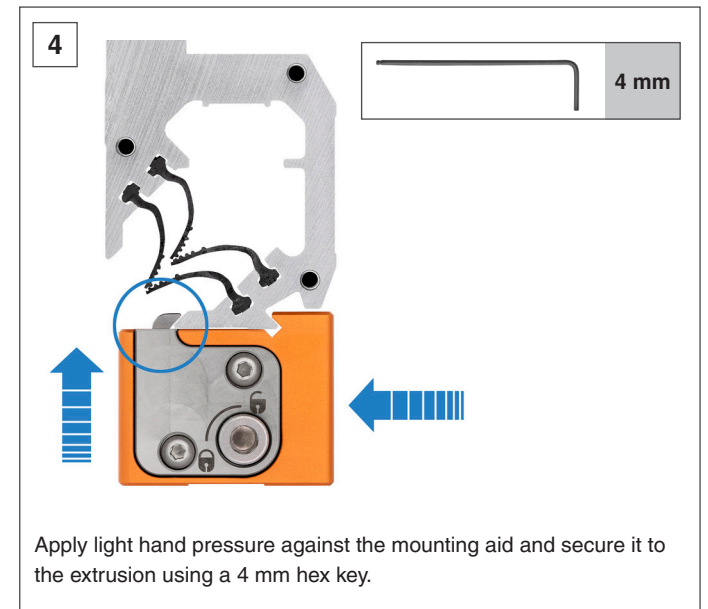
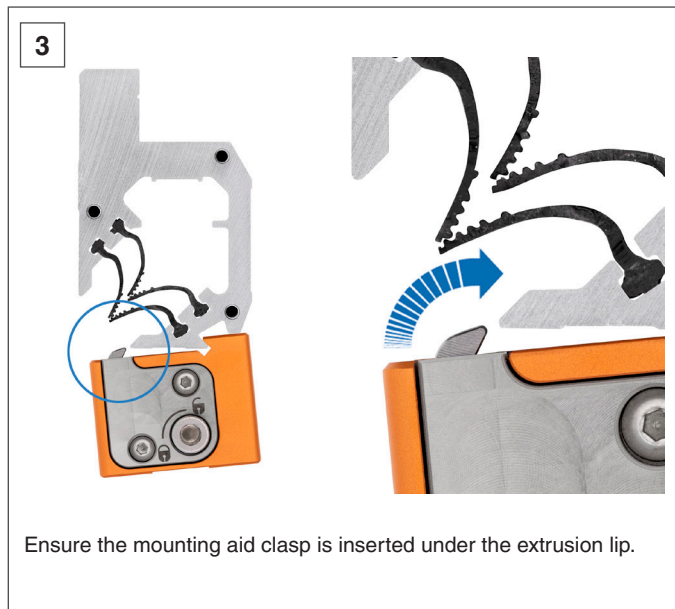
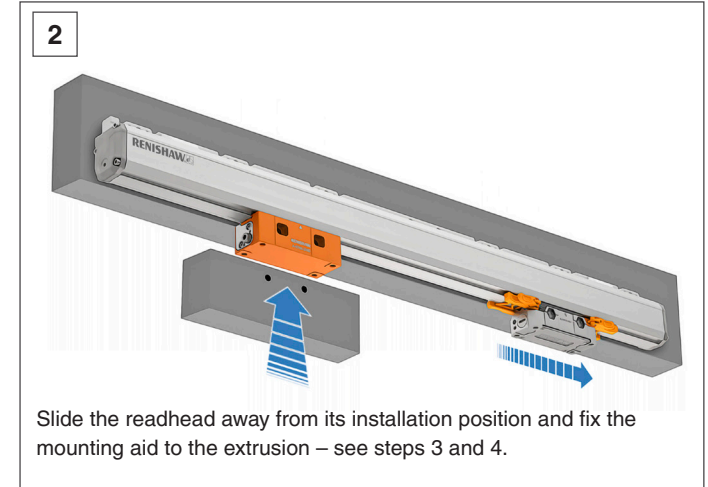
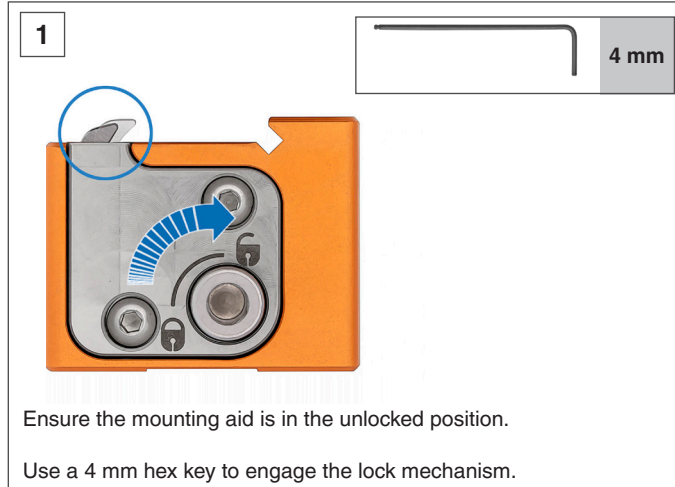

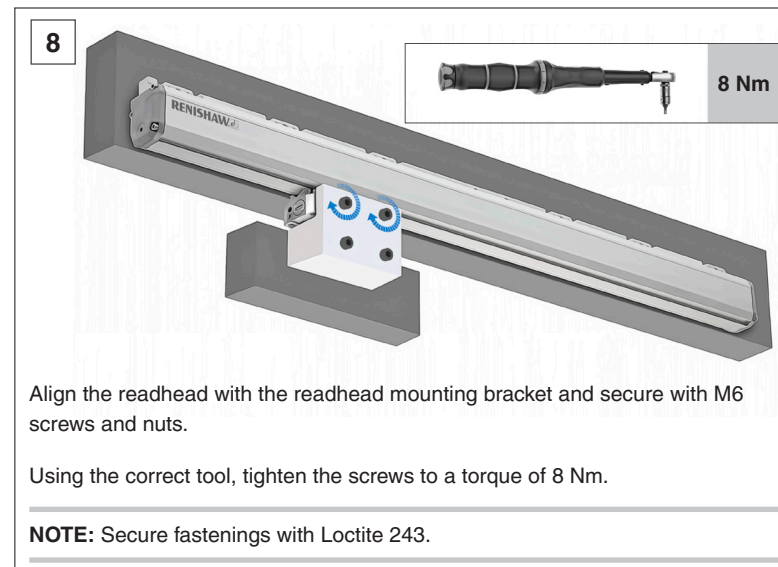
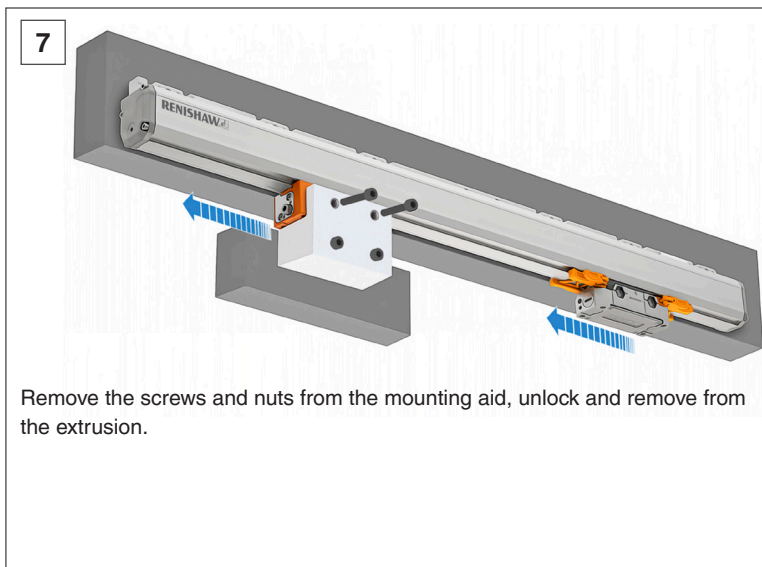
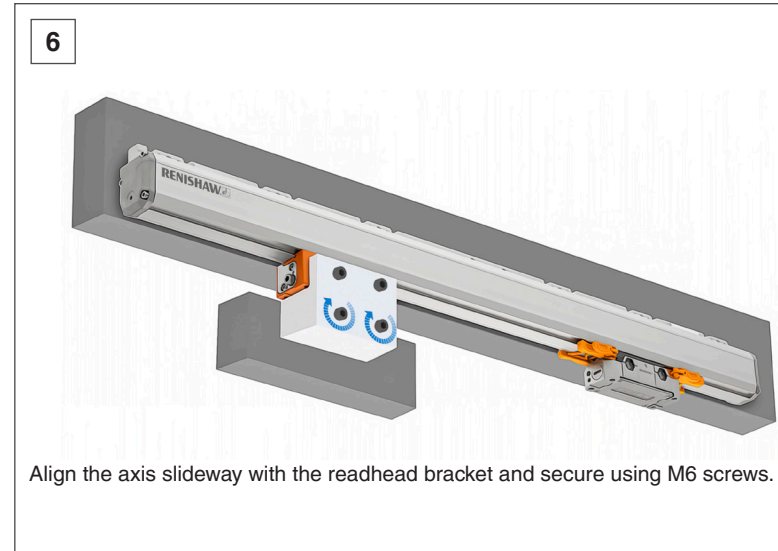
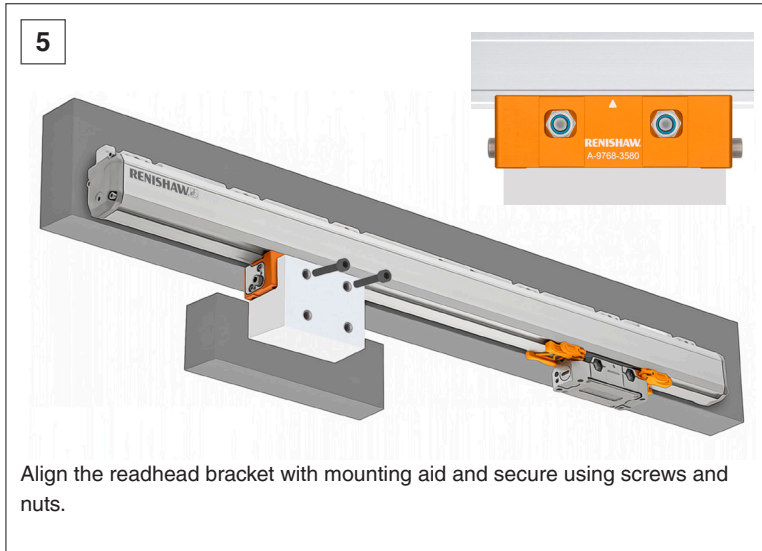

8.5 FORTiS cable connection

To assist with cable management the FORTiS-S system has two cable entry ports, allowing the cable to be inserted into either side of the readhead.

NOTE: Cable connection thread should be secured with Loctite 222.

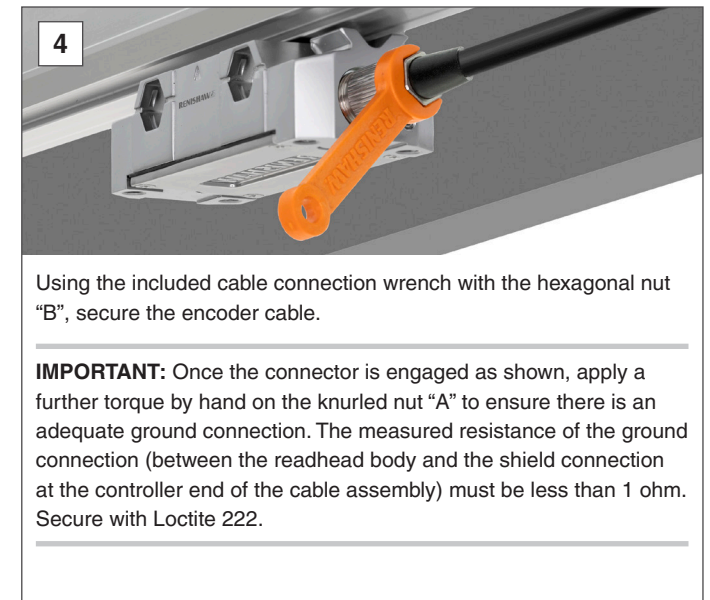
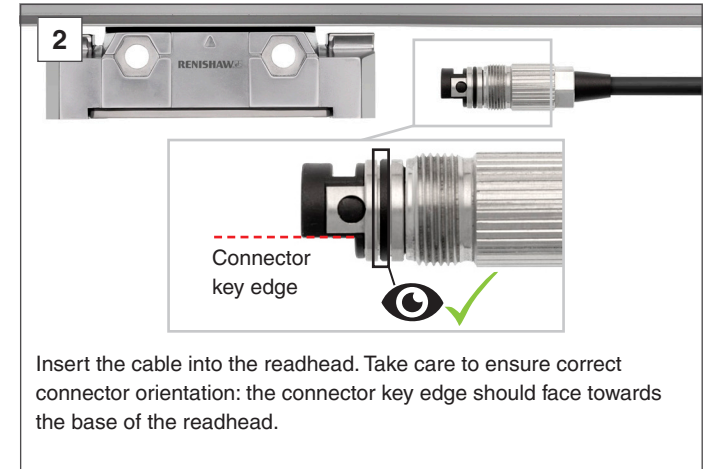
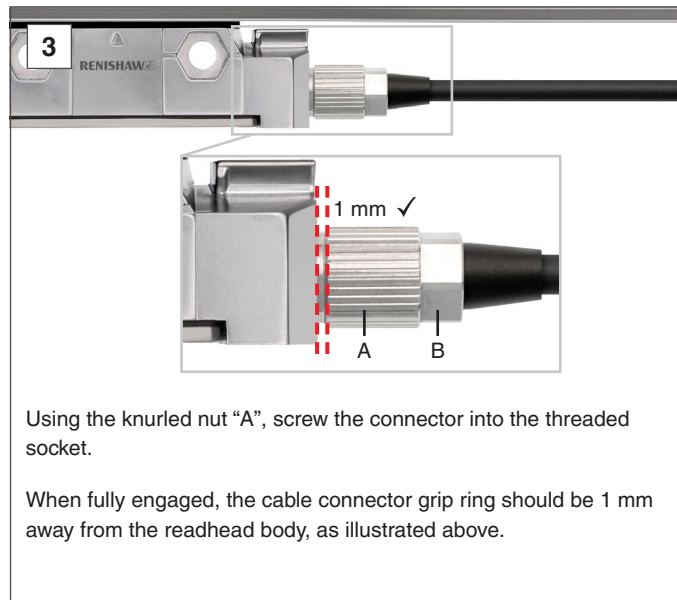
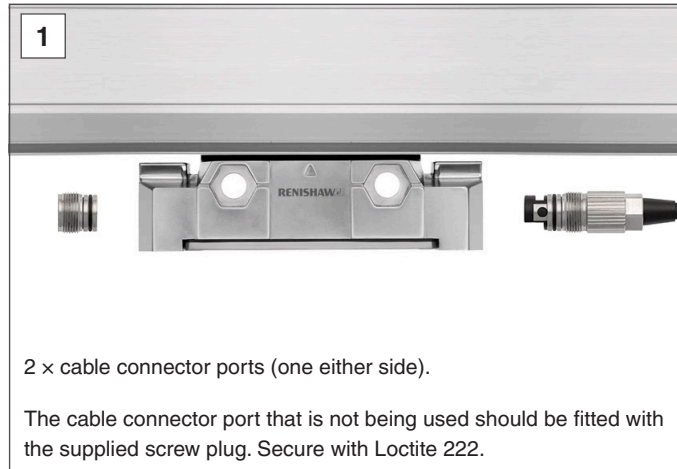





8.6 Validating an installation

To validate the encoder installation the set-up LED provides instant verification of the encoder's signal strength and therefore its accurate alignment and installation.

The encoder requires power to enable the set-up LED; this can be via an appropriate cable plugged into the machine's controller. See [section 9](#) on page 31 for encoder power supply requirements.

NOTE: If the set-up LED is obscured then the signal strength can be obtained using the Advanced Diagnostic Tool for absolute encoders (ADTa-100).

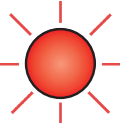
LED status	Description	Required action
 BLUE	Signal level is optimal	No adjustment required
 GREEN	Signal level is good	No adjustment required
 ORANGE	Signal level is acceptable	Ensure the extrusion is parallel to the machine axis of motion (see section 5 on page 13) and adjust the readhead to maximise the signal strength along the full axis of travel to achieve a green or blue LED
 RED	Signal level is NOT acceptable	
 FLASHING RED	Unable to determine the position	<p>Readhead not picking up the scale due to contamination or poor installation</p> <hr/> <p>NOTE: Flashing LED indicates scale reading error. Flashing state is latched for some serial interfaces.</p> <hr/> <p>Remove power to reset.</p>

8.7 Air supply

FORTIS system encoders can be operated with an additional compressed air supply to increase the level of ingress protection from IP53 to IP64. If using air purge the air supply must meet pressure and cleanliness criteria as shown in the table below at the supply input of the encoder.

Air supply cleanliness requirements		
Air supply pressure	1 bar (pressure at encoder air inlet; air inlet connector has an integrated throttle that ensures the correct volume of airflow of 2 l/min through the encoder)	
Maximum particulate contamination	ISO 8573-1 Class 1	
	Particle size	No. of particles per m ³
	0.1 µm to 0.5 µm	≤ 20 000
	0.5 µm to 1.0 µm	≤ 400
	1.0 µm to 5.0 µm	≤ 10
Max pressure dew point	ISO 8573-1 Class 4 (pressure dew point at 3 °C)	
Total oil content	ISO 8573-1 Class 1 (maximum oil concentration: 0.01 mg/m ³)	

The air purge supply is normally connected to the system part that will be stationary. Depending on the machine configuration, either the extrusion or the readhead will move with the machine guideway.

Air inlets are included on both sides of the readhead and on both the extrusion end caps. Use a suitable air supply hose with a 4 mm bore.

For compatible air supply components refer to the data sheet *Air filtration systems for use with FORTIS encoders* (Renishaw part number L-9517-9982).



Full-size air filter
(Renishaw part no. A-9768-4353)



Reduced-size air filter
(Renishaw part no. A-9768-4354)

NOTE: If an air bung or air connector screw requires replacement or repositioning it should be secured with Loctite 222.

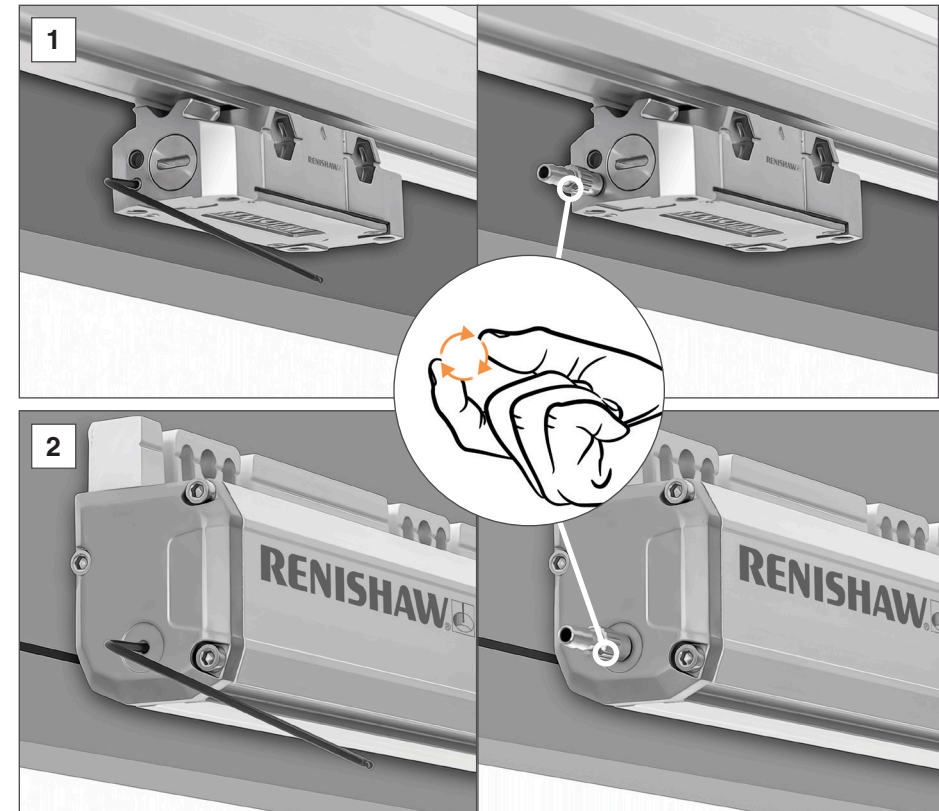

Removal of the air supply bung and fitment of the air connection fitting into either the readhead (1) or extrusion end cap (2). Finger tighten (0.3 Nm maximum).

WARNING: Remove the blanking plug only from the position at which the purge air supply is to be connected, or the sealing integrity may be compromised.

9 Electrical connections

9.1 Electrical preparation

It is necessary to power the FORTiS readhead to install the system correctly.

- Input voltage requirement at readhead carriage: 5 Vdc \pm 5%.
- Operating current: 250 mA.
- Operating power @5 V: 1.25 W.

The system must be earthed as per the image opposite.

9.2 FORTiS grounding and shielding

IMPORTANT:

1. The shield should be connected to the machine earth (field ground).
2. If the flying lead variant is used or the connector is modified or replaced, the customer must ensure that both 0 V cores (white and green) are connected to 0 V. In such situations, care should also be taken to ensure that 0 V and earth remain properly insulated from each other throughout the cable run.

NOTE: On Siemens DRIVE-CLiQ systems, the connector between the readhead cable and extension cable will mate via the interface (Renishaw part no. A-9796-0575).

Figure 1 Standard arrangement.

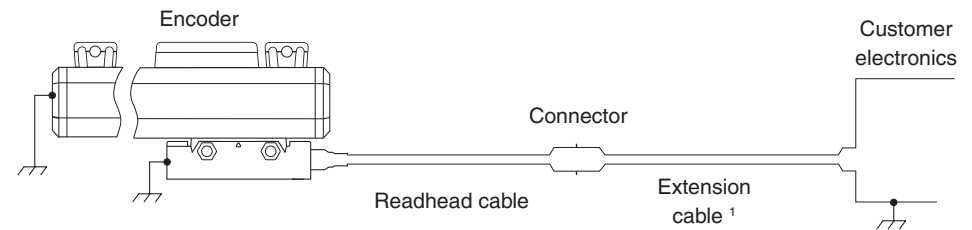

Figure 2 Arrangement for Siemens DRIVE-CLiQ versions.

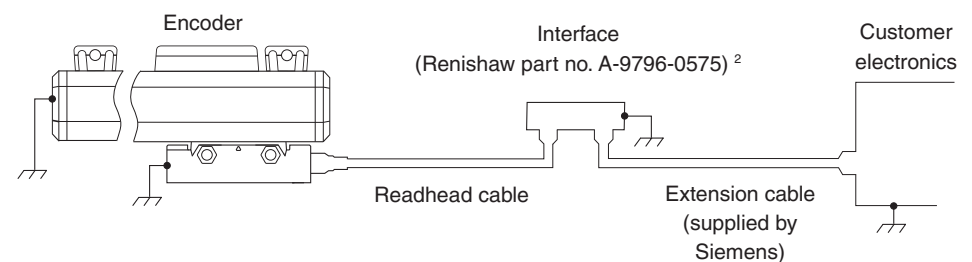
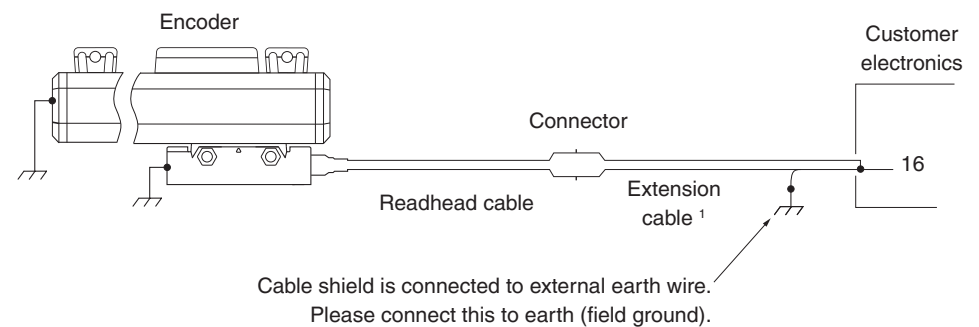

Figure 3 Arrangement when 20-way Honda connector (plastic body) is used with FANUC.



¹ For maximum extension cable length please consult your local Renishaw representative.

² See page 40 for details.

10 Cables and serial interfaces

Further information relating to cables for the FORTiS encoder range can be found in the data sheet *Cables for FORTiS absolute encoders* (Renishaw part no. L-9517-0069). This can be downloaded from our website www.renishaw.com/fortisdownloads and is also available from your local Renishaw representative.

10.1 General specifications

Readhead cable	Type A	Ø4.7 mm, 28 AWG, 7 core, single screen, black jacket Flex life > 20 × 10 ⁶ cycles at 20 mm bend radius Minimum static bend radius (internal radius): 15 mm
	Type B	OD: 6.3 mm, 23 AWG, 6 core (3 × twisted pairs), single screen, green jacket Flex life > 20 × 10 ⁶ cycles at 75 mm bend radius Minimum static bend radius (internal radius): 31.5 mm
	Type D	Armoured: OD 10 mm, 28 AWG, 7 core Flex life > 20 × 10 ⁶ cycles at 100 mm bend radius Minimum static bend radius (internal radius): 35 mm
Extension cable (if applicable)	Type B	OD: 6.3 mm, 23 AWG, 6 core (3 × twisted pairs), single screen, green jacket Flex life > 20 × 10 ⁶ cycles at 75 mm bend radius Minimum static bend radius (internal radius): 31.5 mm
	Type C	OD: 7.8 mm, 2 × 20 AWG (power), 4 × 23 AWG (signal), 2 × 28 AWG (sense), single screen, green jacket Flex life > 20 × 10 ⁶ cycles at 75 mm bend radius Minimum static bend radius (internal radius): 58 mm

CAUTION: The FORTiS encoder system has been designed to the relevant EMC standards, but must be correctly integrated to achieve EMC compliance. In particular, attention to shielding arrangements is essential.

10.2 Permissible cable lengths

The tables below show permissible cable and extension cable combinations for the FORTiS range of enclosed linear encoders. For longer extension cable lengths, a shorter readhead cable is required. This information is valid for all serial interfaces and connector types. At the worse case the minimum acceptable supply voltage is 4.75 Vdc.

NOTE: For Siemens systems, the distance between the readhead and the DRIVE-CLiQ interface must adhere to the restrictions shown in the tables in this section, but the combination of readhead cable and extension cable **MUST NOT EXCEED 25 m**.

10.2.1 Type A readhead cable combined with an extension cable

The following graph shows the maximum length for a cable run when a combination of Type A readhead cable and either Type B or Type C extension cable is used. To read this graph, find the length of readhead cable on the x axis, then the y axis will indicate the maximum extension cable length for each type of extension cable.

Extension cable length (m)

Key

- Maximum Type B cable length - - - - -
- Maximum Type C cable length —————

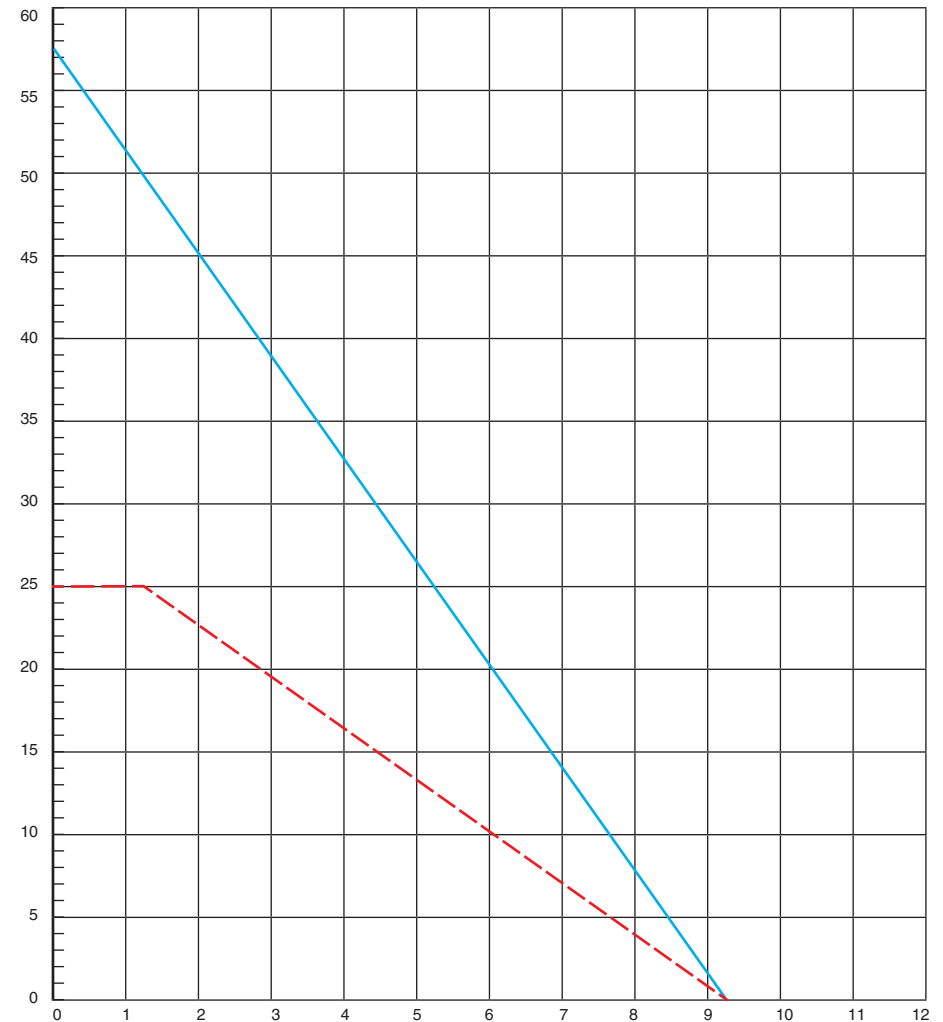

Type A, 28 AWG readhead cable length (m)

10.2.2 Type B readhead cable combined with an extension cable

The following graph shows the maximum length for a cable run when a combination of Type B readhead cable and either Type B or Type C extension cable is used. To read this graph, find the length of readhead cable on the x axis, then the y axis will indicate the maximum extension cable length for each type of extension cable.

Extension cable length (m)

Key

- Maximum Type B cable length - - - - -
- Maximum Type C cable length —————

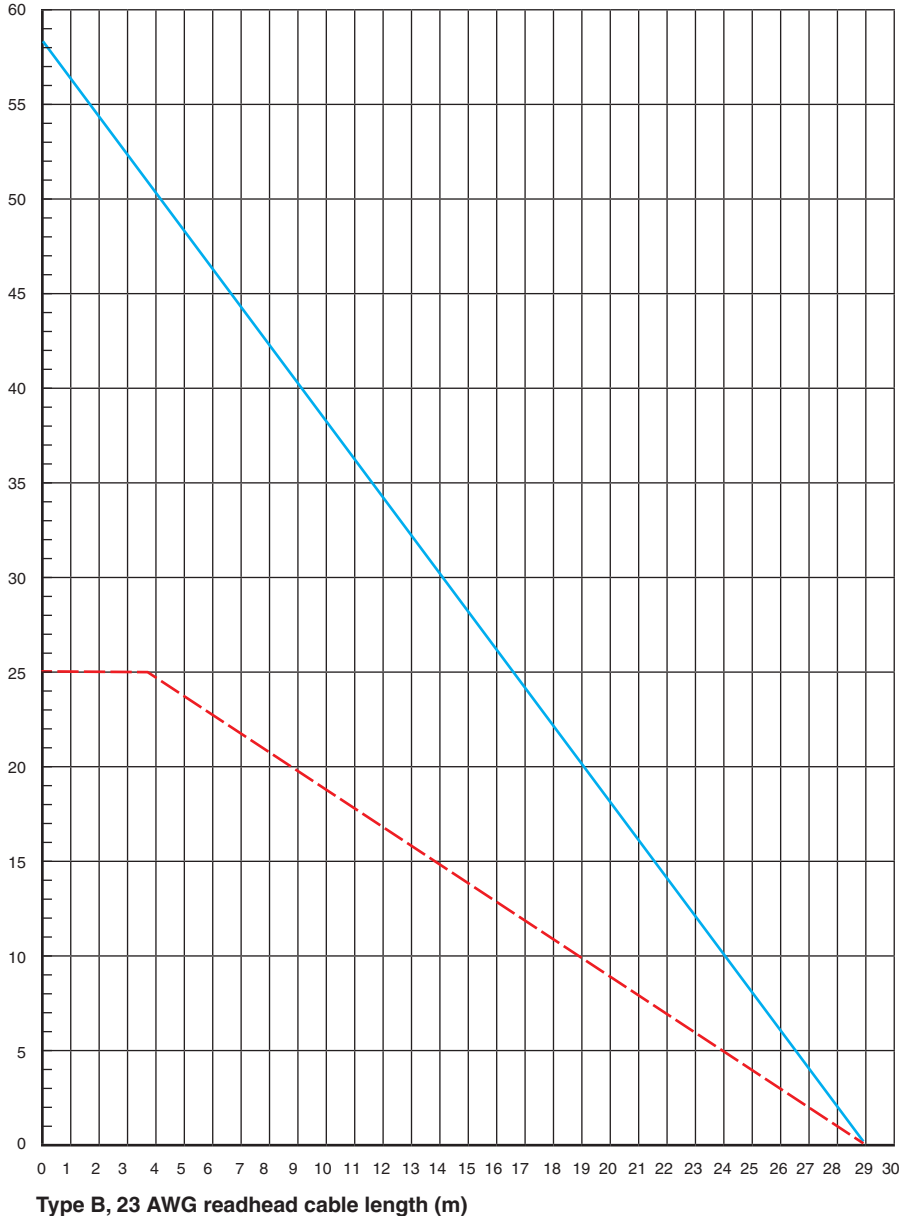

10.3 BiSS C serial interface

10.3.1 Controller connector

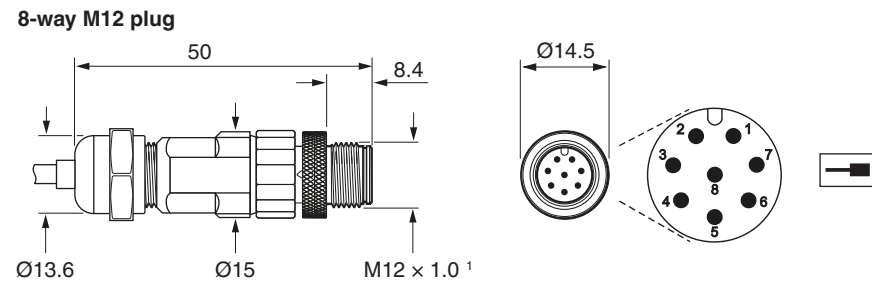
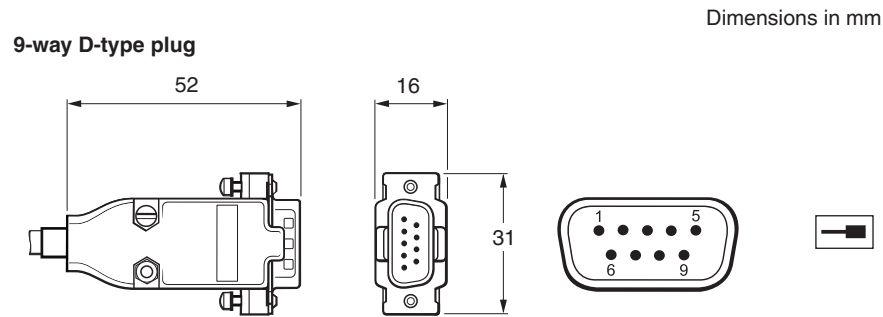

¹ The recommended tightening torque is 4 Nm.

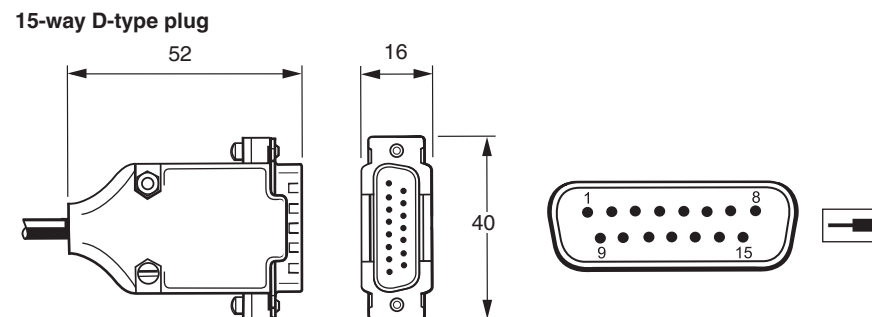

10.3.2 In-line connector

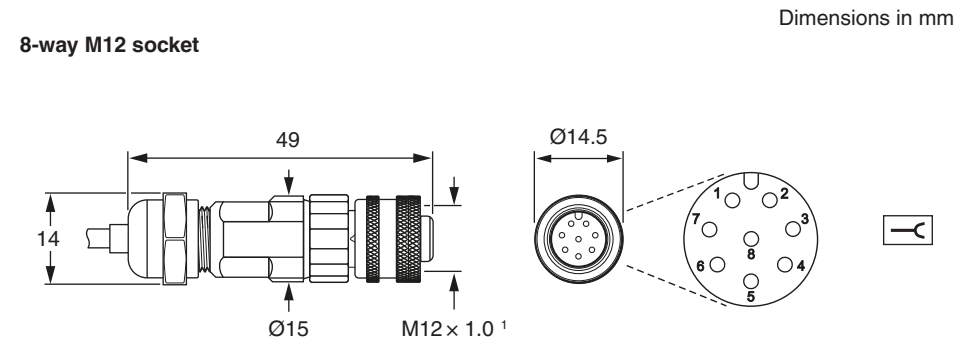

¹ The recommended tightening torque is 4 Nm.

10.3.3 Output signals

Function	Signal	Flying lead wire colour (F)	Pin-out		
			9-way D-type (A)	8-way M12 (S)	15-way D-type (D)
Power	5 V	Brown	4, 5	2	4, 12
	0 V	White	8, 9	5, 8	2, 10
Serial interface	MA+	Violet	2	3	8
	MA-	Yellow	3	4	15
	SLO+	Grey	6	7	5
	SLO-	Pink	7	6	13
Shield	Shield	Shield	Case	Case	Case

10.4 FANUC serial interface

10.4.1 Controller connector

20-way plug

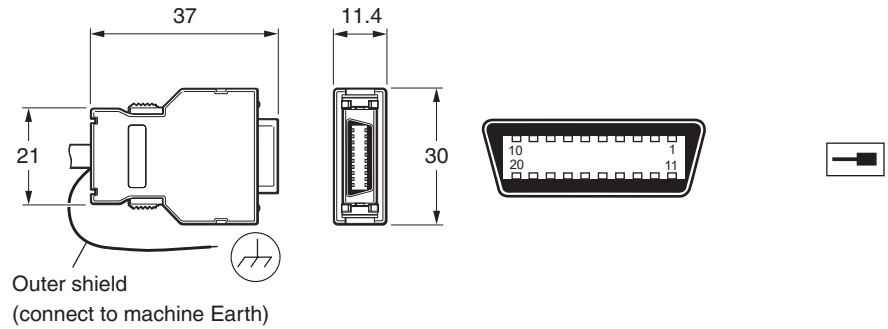

8-way M12 plug

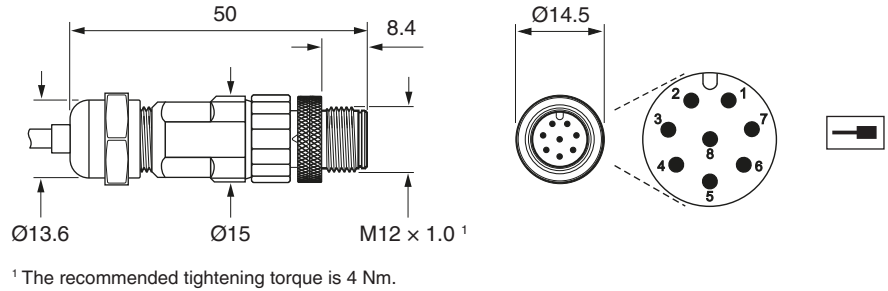

17-way M23 plug

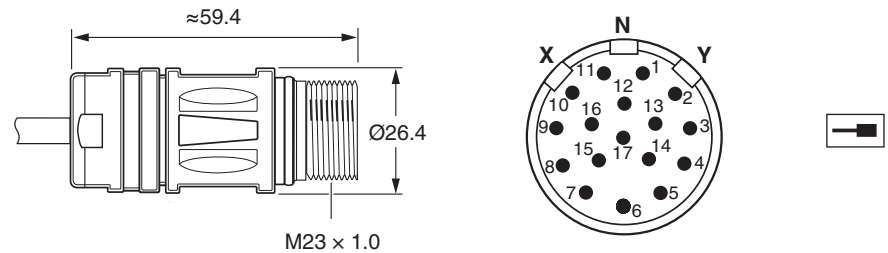

10.4.2 In-line connector

8-way M12 socket

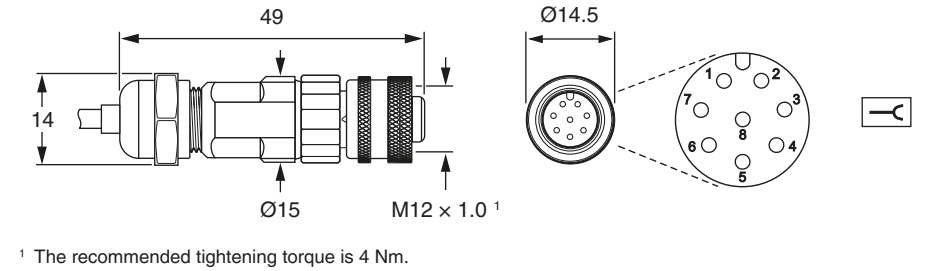

17-way M23 socket

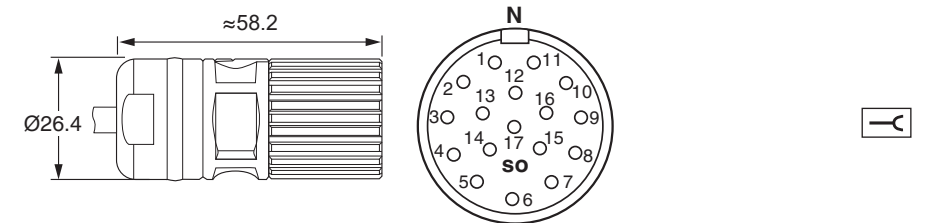

10.4.3 Output signals

Function	Signal		Flying lead wire colour (F)	Pin-out			
	FANUC α	FANUC α i		20-way plug (H)	8-way M12 (S)	8-way M12 (T)	17-way M23 (C)
Power	5 V	5 V	Brown	9, 20	2	8	1, 7
	0 V	0 V	White	12, 14	5, 8	5	4, 10
Serial interface	REQ+	REQ+ / SD+	Violet	5	3	7	8
	REQ-	REQ- / SD-	Yellow	6	4	6	9
	SD+	Do not connect	Grey	1	7	3	14
	SD-		Pink	2	6	4	17
Shield	Shield	Shield	Cable braid	16, External	Case	Case	Case

10.4.4 Connecting the cable screen on H terminations

 The following arrangement should be applied to FANUC versions only.

The cable is supplied with the shield connected to pin 16 inside the connector, making the required connection to the FANUC equipment. The shield must also be connected to machine Earth, either by using the external Earth wire provided, or by cutting back the cable insulation to expose the shield and clamping that to machine Earth.

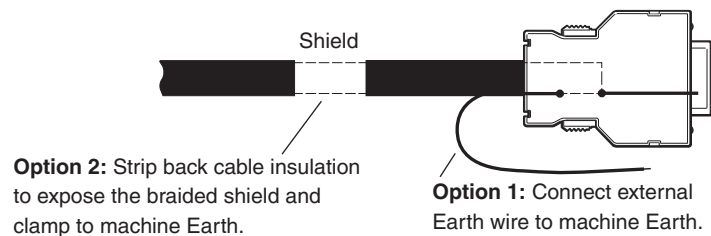

10.5 Mitsubishi serial interface

10.5.1 Controller connector

Dimensions in mm

8-way M12 plug

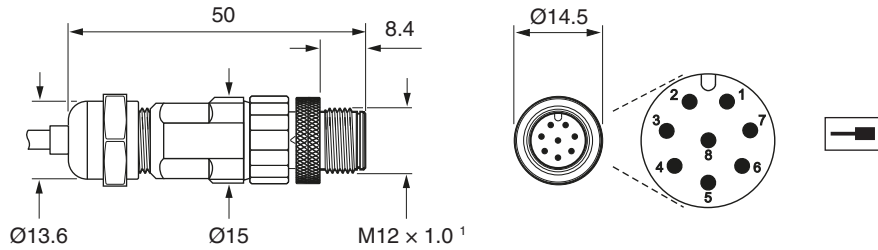

¹ The recommended tightening torque is 4 Nm.

10-way 3M plug

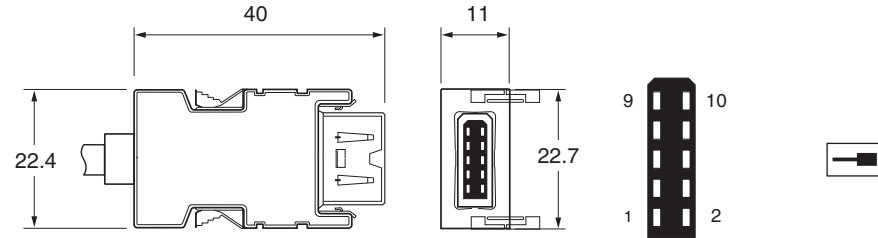

17-way M23 plug

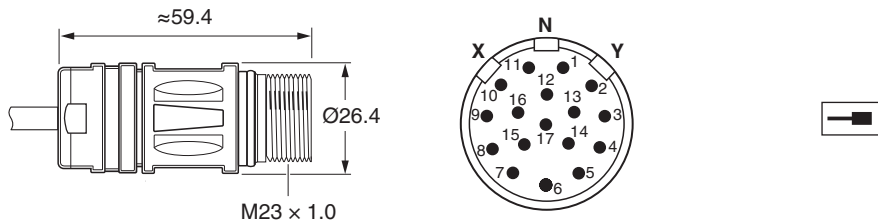

10.5.2 In-line connector

Dimensions in mm

8-way M12 socket

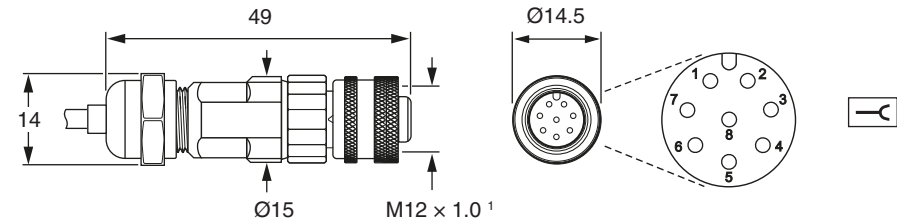

¹ The recommended tightening torque is 4 Nm.

17-way M23 socket

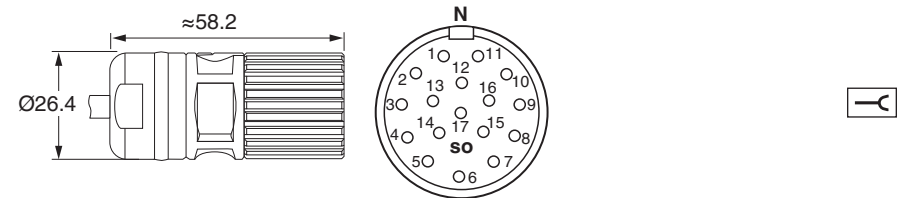

10.5.3 Output signals

Function	Signal	Flying lead wire colour (F)	Pin-out		
			10-way 3M (P)	8-way M12 (S)	8-way M12 (T)
Power	5 V	Brown	1	2	8
	0 V	White	2	5, 8	5
Serial interface	MR	Violet	3	3	7
	MRR	Yellow	4	4	6
	MD	Grey	7	7	3
	MDR	Pink	8	6	4
Shield	Shield	Shield	Case	Case	Case

10.6 Panasonic serial interface

10.6.1 Controller connector

Dimensions in mm

8-way M12 plug

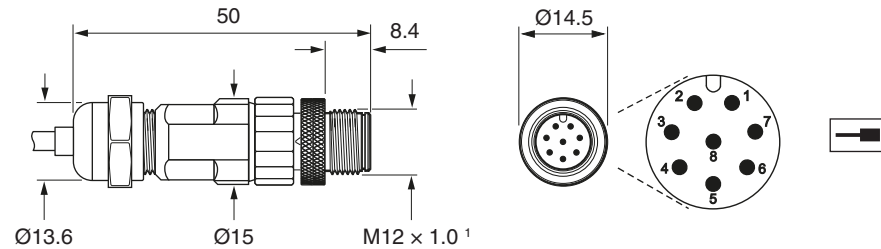

¹ The recommended tightening torque is 4 Nm.

10-way JST plug

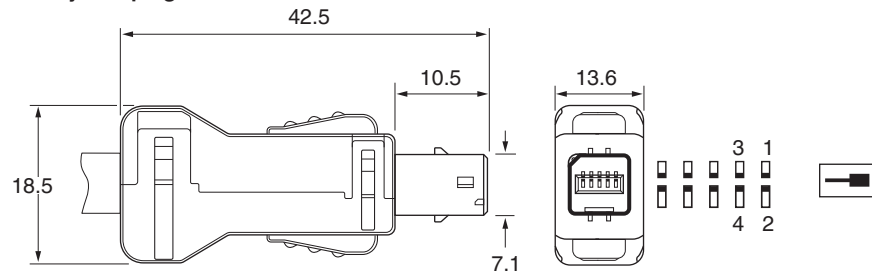

10.6.2 In-line connector

Dimensions in mm

8-way M12 socket

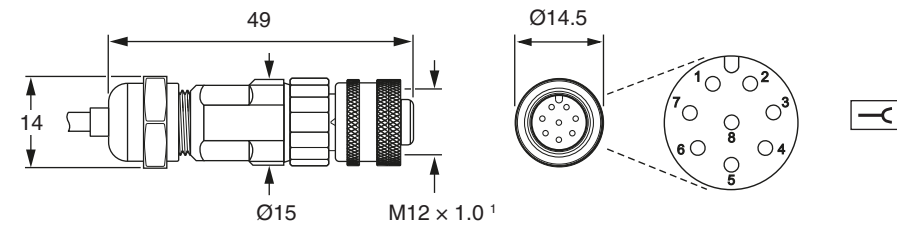

¹ The recommended tightening torque is 4 Nm.

10.6.3 Output signals

Function	Signal	Flying lead wire colour (F)	Pin-out	
			8-way M12 (S)	10-way JST (J)
Power	5 V	Brown	2	1
	0 V	White	5, 8	2
		Green		-
Serial interface	PS	Violet	3	3
	\overline{PS}	Yellow	4	4
Reserved	Do not connect	Grey	7	-
		Pink	6	-
Shield	Shield	Shield	Case	Case

10.7 Siemens serial interface

Included with Siemens-only versions of FORTiS.

DRIVE-CLiQ interface connector		
Power supply	24 V	1.8 W maximum (75 mA @ 24 V), 24 V as per DRIVE-CLiQ specification. 24 V power is provided by the DRIVE-CLiQ network Overvoltage protection for DRIVE-CLiQ: -36V to +36V
	Ripple	200 mVpp maximum @ frequency up to 500 kHz
Maximum total cable length	Readhead to DRIVE-CLiQ interface 9 m (Refer to Siemens DRIVE-CLiQ specifications for maximum cable length from interface to controller) Extension cables from the FORTiS DRIVE-CLiQ interface to controller should be sourced directly from Siemens	
Connector tightening torque	M12 – 4 Nm	

10.7.1 Controller connector

Dimensions in mm

8-way M12 plug

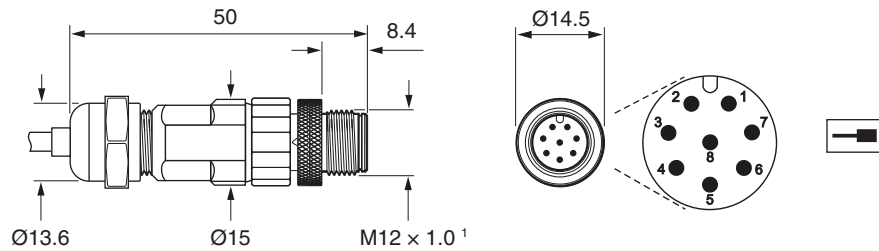

¹ The recommended tightening torque is 4 Nm.

10.7.2 In-line connector

Dimensions in mm

8-way M12 socket

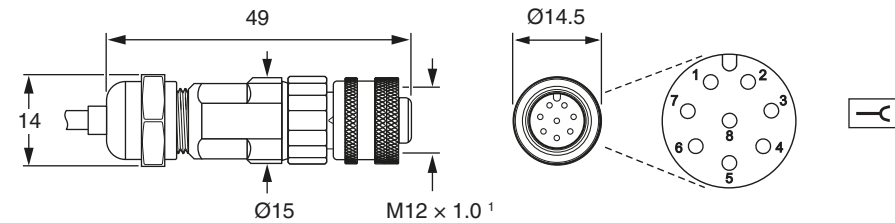

¹ The recommended tightening torque is 4 Nm.

10.7.3 Output signals

Function	Signal	Wire colour	Pin-out
			8-way M12 (S)
Power	5 V	Brown	2
	0 V	White	5, 8
Serial interface	A+	Violet	3
	A-	Yellow	4
Reserved	Do not connect	Grey	7
		Pink	6
Shield	Shield	Shield	Case

10.7.4 Siemens DRIVE-CLiQ serial interface

10.7.4.1 RDY LED functions

Colour	Status	Description
-	Off	Power supply is missing or outside permissible tolerance range
Green	Continuous light	The component is ready for operation and cyclic DRIVE-CLiQ communication is taking place
Orange	Continuous light	DRIVE-CLiQ communication is being established
Red	Continuous light	At least one fault is present in this component NOTE: The LED is activated regardless of whether the corresponding messages have been reconfigured.
Green/ Orange or Red/ Orange	Flashing light	Component recognition via LED is activated (p0144) NOTE: Both options depend on the LED status when component recognition is activated via p0144=1.

10.7.4.2 Status LED function

STATUS displays the readhead set-up status as shown on the readhead set-up LED; see [section 8.6](#) on page 29 for more details.

10.7.5 Siemens DRIVE-CLiQ interface output

Function	Signal	Pin-out M12
Power	24 V	1
	0 V	5
DRIVE-CLiQ serial interface	RX+	3
	RX-	4
	TX+	7
	TX-	6
Shield	Shield	Case

10.7.6 Siemens DRIVE-CLiQ interface installation drawing

Single readhead (Renishaw part no. A-9796-0575)



Dimensions in mm

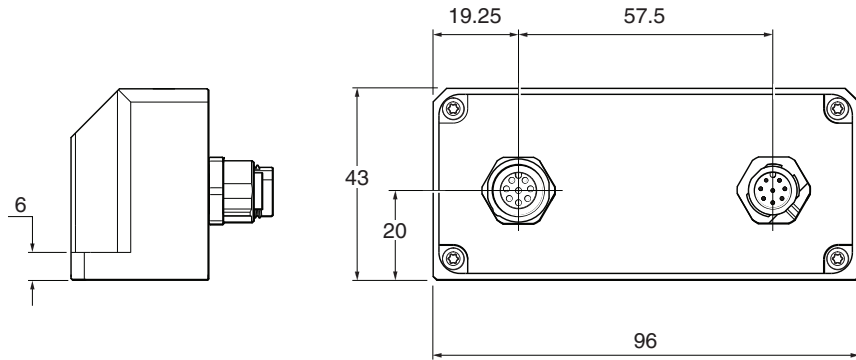
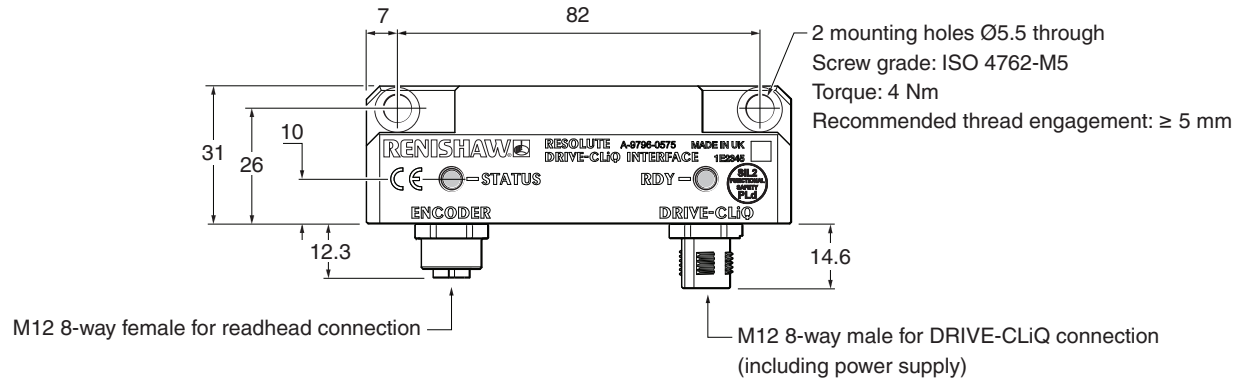

10.8 Yaskawa serial interface

10.8.1 Controller connector

Dimensions in mm

8-way M12 plug

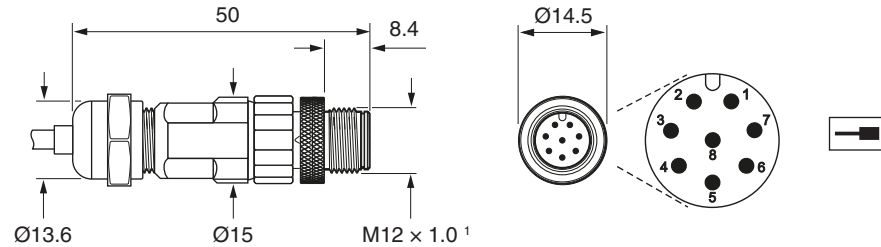

¹ The recommended tightening torque is 4 Nm.

6-way Molex plug

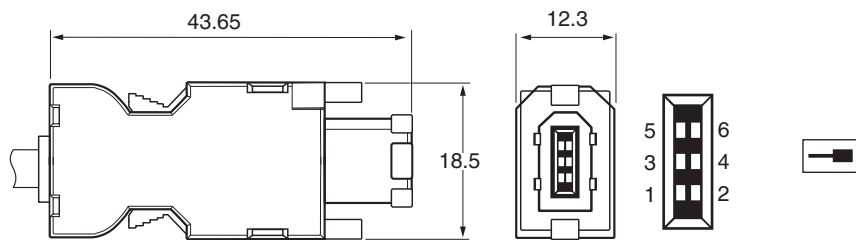

10.8.2 In-line connector

Dimensions in mm

8-way M12 socket

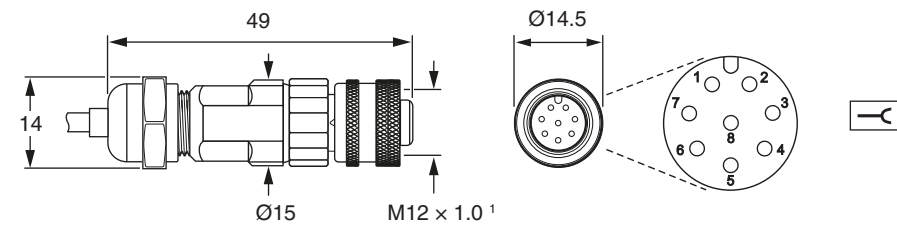



¹ The recommended tightening torque is 4 Nm.

10.8.3 Output signals

Function	Signal	Flying lead wire colour (F)	Pin-out	
			8-way M12 (S)	6-way Molex (Y)
Power	5 V	Brown	2	1
	0 V	White	5, 8	2
		Green		Not connected
Serial interface	S	Violet	3	5
	\bar{S}	Yellow	4	6
Reserved	Do not connect	Grey	7	-
		Pink	6	-
Shield	Shield	Shield	Case	Case

www.renishaw.com/contact

 #renishaw

 +44 (0) 1453 524524  uk@renishaw.com

© 2018–2024 Renishaw plc. All rights reserved. This document may not be copied or reproduced in whole or in part, or transferred to any other media or language by any means, without the prior written permission of Renishaw.
RENISHAW® and the probe symbol are registered trade marks of Renishaw plc. Renishaw product names, designations and the mark "apply innovation" are trade marks of Renishaw plc or its subsidiaries.
BiSS® is a registered trade mark of iC-Haus GmbH. Loctite® is a registered trade mark of the Henkel Corporation.
Other brand, product or company names are trade marks of their respective owners.
Renishaw plc. Registered in England and Wales. Company no: 1106260. Registered office: New Mills, Wotton-under-Edge, Glos, GL12 8JR, UK.

WHILE CONSIDERABLE EFFORT WAS MADE TO VERIFY THE ACCURACY OF THIS DOCUMENT AT PUBLICATION, ALL WARRANTIES, CONDITIONS, REPRESENTATIONS AND LIABILITY, HOWSOEVER ARISING, ARE EXCLUDED TO THE EXTENT PERMITTED BY LAW.

RENISHAW RESERVES THE RIGHT TO MAKE CHANGES TO THIS DOCUMENT AND TO THE EQUIPMENT, AND/OR SOFTWARE AND THE SPECIFICATION DESCRIBED HEREIN WITHOUT OBLIGATION TO PROVIDE NOTICE OF SUCH CHANGES.

Part no.: M-9768-9857-03-B
Issued: 08.2024