

TS20 two axis tool setting probe for lathes



Specification

TS20 probe with straight stylus

Sense directions	Normally $\pm X$ and $\pm Z$ axes of a lathe
Uni-directional repeatability. Maximum mean 2 sigma (2σ) value	2 μm (0.00008 in) Valid for test velocity of 480 mm/min (1.57 ft/min) at stylus tip
Temperature limits: Operating Storage	5° to 60° C (41° to 140° F) -13° to 60° C (9° to 140° F)

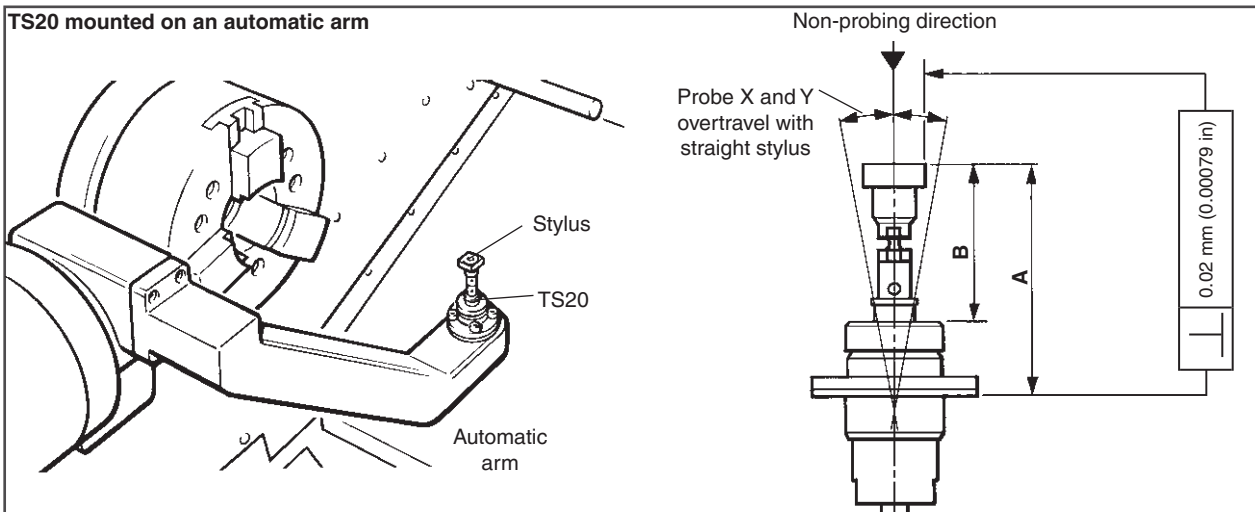

Tooling size	Dimension A	Dimension B	Stylus overtravel with straight styli	Uni-directional repeatability 2σ At a probing speed of 480 mm/min (1.57 ft/min)	Trigger force dependent on sense direction
25 mm (0.98 in)	41 mm (1.61 in)	28.25 mm (1.11 in)	± 6 mm (± 0.24 in)	2.0 μm (0.00008 in)	0.60 - 1.6 N 60 - 160 gf (2.12 - 5.64 ozf)
32 mm (1.26 in)	50 mm (1.96 in)	37.25 mm (1.46 in)	± 7.5 mm (± 0.30 in)	2.5 μm (0.0001 in)	0.47 - 1.26 N 47 - 126 gf (1.66 - 4.44 ozf)
40 mm (1.57 in)	58 mm (2.28 in)	58 mm (2.28 in)	± 9 mm (± 0.35 in)	3.0 μm (0.00012 in)	0.39 - 1.6 N 39 - 106 gf (1.38 - 3.74 ozf)

Specification

TS20 probe with cranked stylus for applications where the straight stylus is not suitable

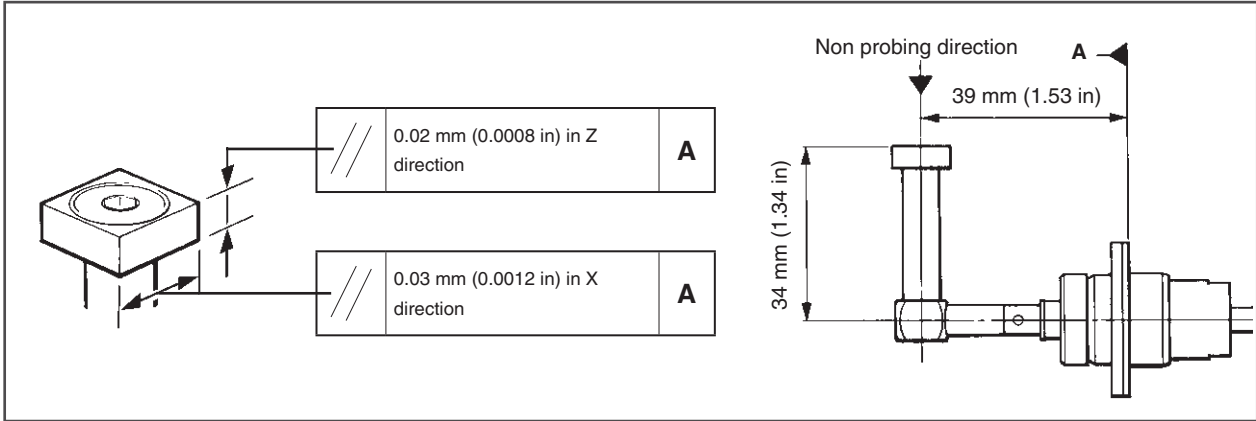

Uni-directional repeatability 2σ At a probing speed of 480 mm/min (1.57 ft/min)	Trigger force (dependent on sense direction)
2 μ m (0.00008 in)	0.6 - 1.6 N, 60 - 160 gf, (2.12 - 5.64 ozf)

NOTE: The characteristics of cranked styli do not allow them to have as good a repeatability performance as straight styli.

Overtravel

Do not exceed the quoted overtravel distance for each direction, otherwise the tool tip may slip off the stylus edge, and could cause damage to the probe.

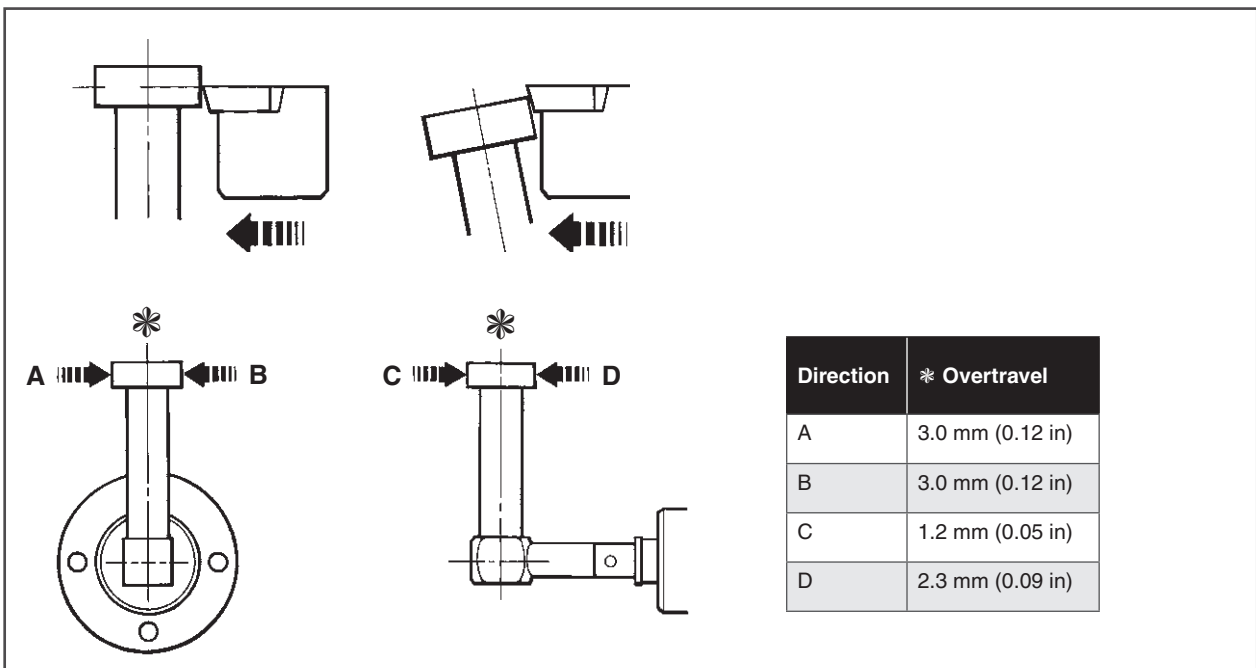

Probe - signal processing options

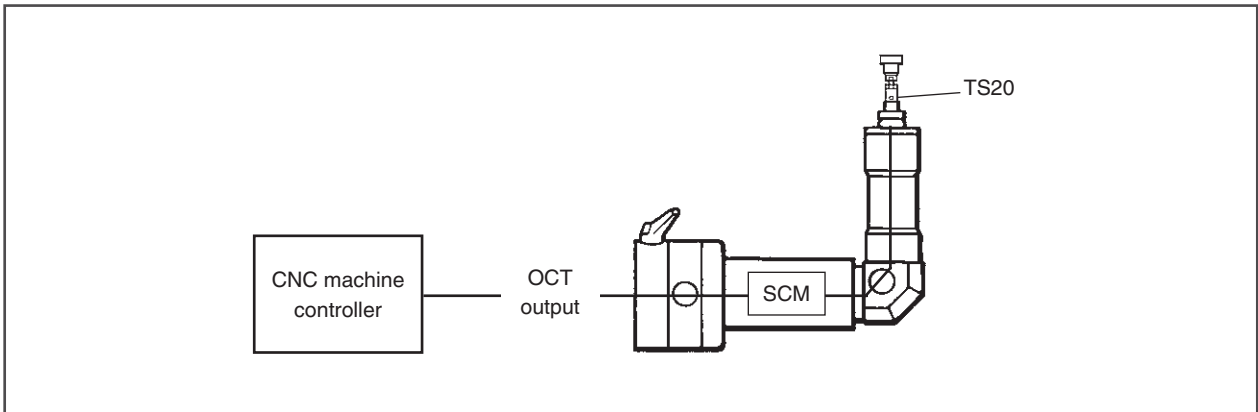

TS20 probe with signal conditioning module

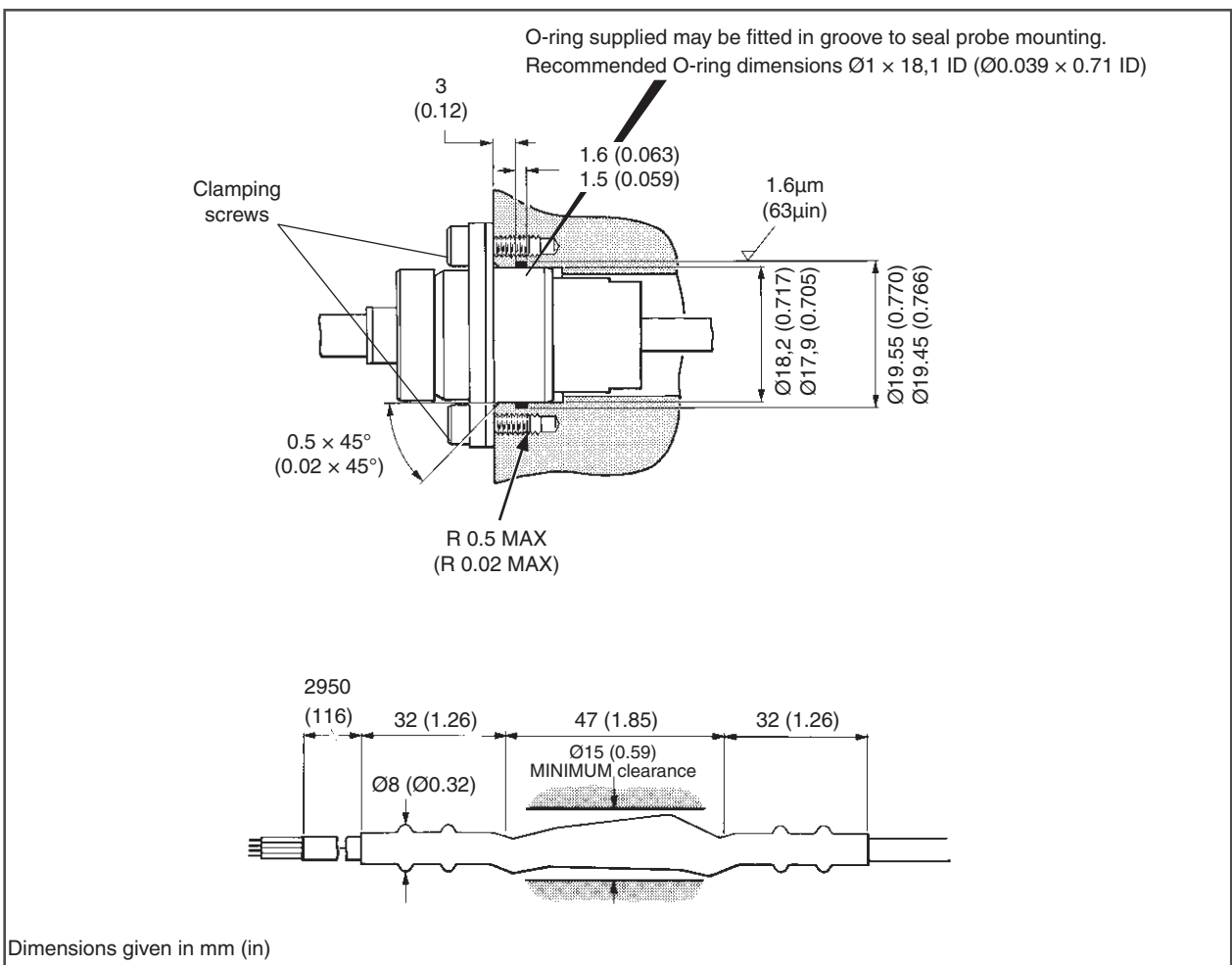

TS20 mounted on an automatic arm with MI 8-4, HSI, or HSI-C interface

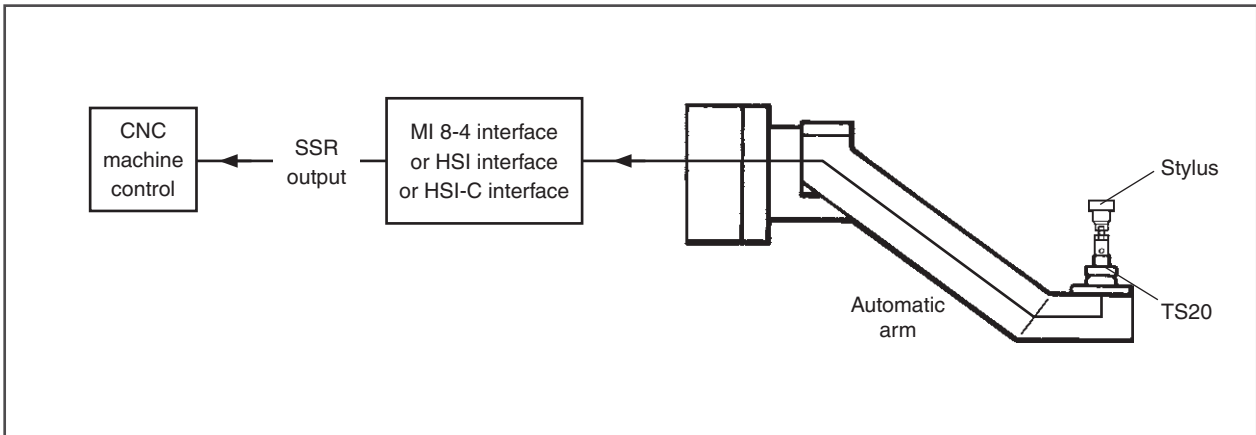

Probe - cable options

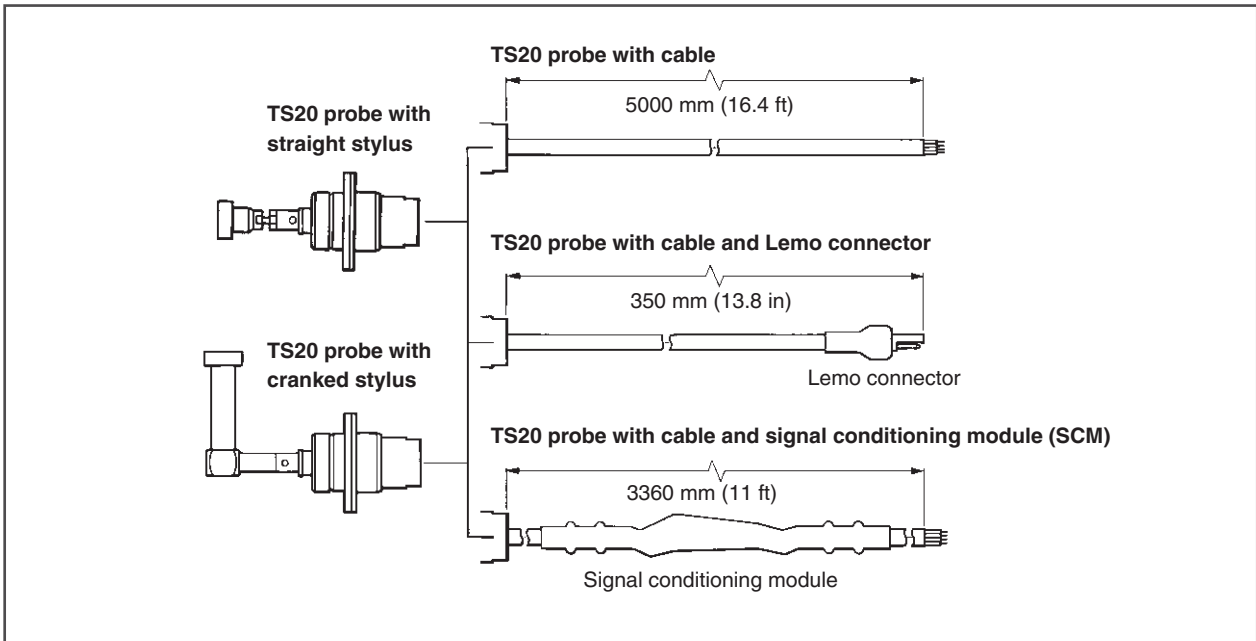

Spare parts and accessories

A full range of spare parts and accessories is available. Contact Renishaw for a full list.

www.renishaw.com/ts20

#renishaw

+44 (0) 1453 524524

uk@renishaw.com

© 2002–2024 Renishaw plc. All rights reserved. This document may not be copied or reproduced in whole or in part, or transferred to any other media or language by any means, without the prior written permission of Renishaw.

RENISHAW® and the probe symbol are registered trade marks of Renishaw plc. Renishaw product names, designations and the mark 'apply innovation' are trade marks of Renishaw plc or its subsidiaries. Other brand, product or company names are trade marks of their respective owners.

WHILE CONSIDERABLE EFFORT WAS MADE TO VERIFY THE ACCURACY OF THIS DOCUMENT AT PUBLICATION, ALL WARRANTIES, CONDITIONS, REPRESENTATIONS AND LIABILITY, HOWSOEVER ARISING, ARE EXCLUDED TO THE EXTENT PERMITTED BY LAW. RENISHAW RESERVES THE RIGHT TO MAKE CHANGES TO THIS DOCUMENT AND TO THE EQUIPMENT, AND/OR SOFTWARE AND THE SPECIFICATION DESCRIBED HEREIN WITHOUT OBLIGATION TO PROVIDE NOTICE OF SUCH CHANGES.

Renishaw plc. Registered in England and Wales. Company no: 1106260. Registered office: New Mills, Wotton-under-Edge, Glos, GL12 8JR, UK.

Part no.: H-2000-2110-15-A

Issued: 03.2024