

REE analogue interface



The REE analogue interface is designed for use with any 1 Vpp analogue readhead.

It applies Automatic Offset, Balance and Gain Control (AOC, ABC, AGC) to the input signals. Accurate, constant amplitude 1 Vpp industry standard signals are then output.

A tri-coloured LED indicates input signal strength and allows ease of setup for optimum performance. If this LED is not visible when the interface is installed, a separate external setup signal can be used and a calibration cycle also helps to simplify installation.

These features result in the output signals having very low cyclic error, typically less than 50 nm.

The interface is fully RoHS compliant and also caters for readheads with single or dual limit outputs.

- Compatible with all standard 1Vpp analogue output readheads
- Outputs accurate, industry standard, 1 Vpp analogue differential signals
- Low cyclic error
- Tri-colour integral set-up LED
- User selectable automatic gain control (AGC)
- Automatic offset and balance control (AOC and ABC)
- Single or dual limit capability

REE installation drawing

Dimensions and tolerances in mm

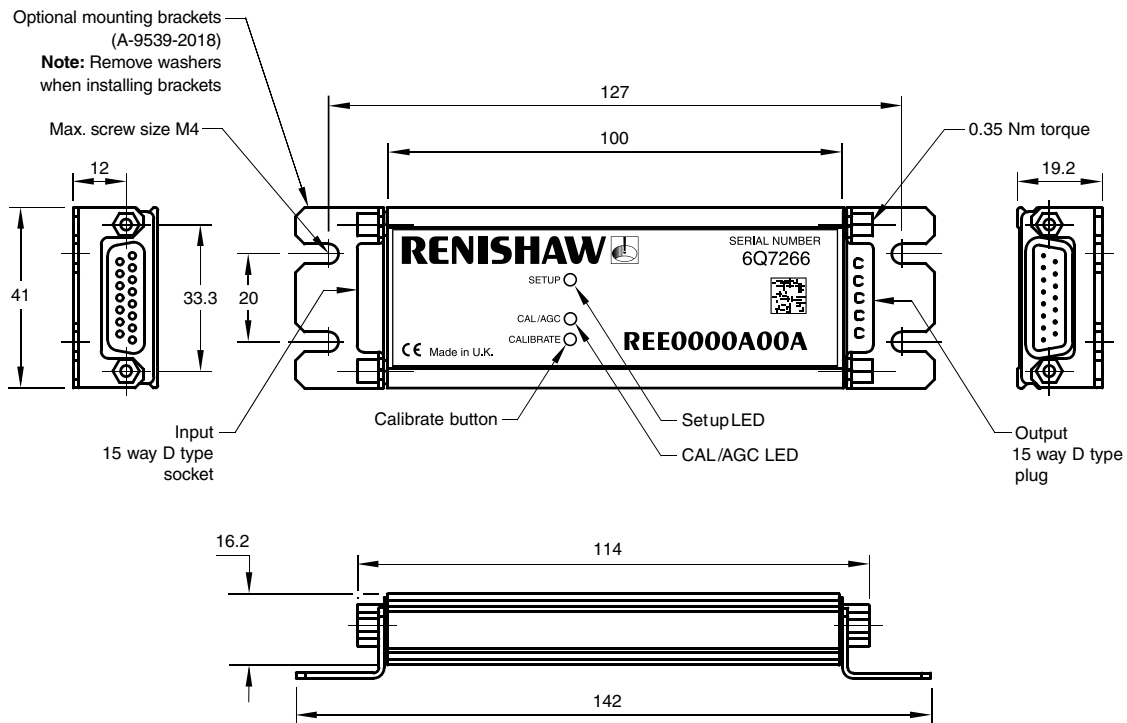

Operating and electrical specifications

Power supply	5 V nominal -5% + 10%	150 mA current consumption (interface only, when terminated with 120 Ω). Provision is given to feed a maximum of an additional 100 mA to the readhead. The interface will be fully active <300 ms after power is applied. Renishaw encoder systems must be powered from a 5 V dc supply complying with the requirements for SELV of standard EN (IEC) 60950. Provision is given for remote sensing via two cores of the customer's cable. The interface and readhead are protected from reverse voltage and over voltage of up to 12 V.
	Ripple	200 mVpp maximum @ frequency up to 500 kHz maximum
Acceleration		Operating 500 m/s ² BS EN 60068-2-7:1993 (IEC 68-2-7:1983)
Shock	non-operating	1000 m/s ² , 6 ms, ½ sine BS EN 60068-2-27:1993 (IEC 68-2-27:1987)
Vibration	operating	100 m/s ² max @ 55 to 2000 Hz BS EN 60068-2-6:1996 (IEC 68-2-6:1995)
Temperature	Storage	-20 °C to +70 °C
	Operating	0 °C to +55 °C
Humidity	Storage	95% maximum relative humidity (non-condensing)
	Operating	80% maximum relative humidity (non-condensing)
Sealing		IP40
Mass		95 g
EMC compliance		BS EN 61000 BS EN 55011
Connectors (input/output)		15-way D type socket/plug

REE interface features

Self-tuning active correction

The REE analogue interface actively corrects for input signal imperfections to optimise system accuracy. Corrections are made for the following:

Automatic Offset Control (AOC) – adjusts offset independently for the sine and cosine signals

Automatic Gain Control (AGC) – ensures consistent 1 Vpp signal amplitude

Automatic Balance Control (ABC) – adjusts the gain to equalise the sine and cosine signals

These correction mechanisms operate over the full working speed range of the readhead. The user can disable/enable the AGC by pressing the CALIBRATE button for greater than 3 seconds.

LED indicators

The tri-coloured SETUP LED provides visual feedback of signal strength and error condition, for setup and diagnostic use.

Flashing Purple indicates high signal alarm condition	>135%
Purple indicates high signal	>110% and <135%
Blue indicates optimum signal	>90% and <110%
Green indicates acceptable signal	>70% and <90%
Orange indicates low signal	>50% and <70%
Red indicates unacceptable signal	>20% and <50%
Flashing Red indicates unacceptable signal alarm condition	<20%
Flashing Blue indicates overspeed alarm condition	
Flashes Off momentarily to indicate a reference mark, up to 100 mm/s only	

The **Yellow** CAL/AGC LED indicates when the REE is in a calibration routine and whether or not AGC is active

LED on indicates AGC active

LED off indicates AGC inactive

LED slow flashing indicates calibration routine

LED fast flashing indicates calibration failure

Reference mark processing

The REE analogue interface monitors the user configurable BID and DIR lines in order to control the outputting of any reference mark.

BID line	DIR line	Reference output
High	High	All, both directions
High	Low	All, both directions
Low	High	Forward direction only
Low	Low	Reverse direction only

Calibration procedure

The calibration procedure is required to optimise the gain, balance and offset of the analogue input signals in the REF interface. These settings are then stored and recalled for initial use at startup.

To calibrate the system, the following sequence should be carried out:

- ▶ Prior to calibration, AGC should be off. To switch AGC on or off, the CALIBRATE button should be pressed for more than 3 seconds. When AGC is on, the CAL/AGC LED will be on and when AGC is off, the CAL/AGC LED will be off.
- ▶ Install the readhead and set up to obtain optimum (1 Vpp) signal amplitude
- ▶ Enter the calibration routine by pressing the CALIBRATE button momentarily. The calibration routine is indicated by slow flashing of the CAL/AGC LED.
- ▶ Traverse the readhead slowly past the scale until the CAL/AGC LED stops flashing. The calibration cycle is now complete.

If calibration fails, the CAL/AGC LED will flash quickly instead of switching off. If this happens the CALIBRATE button should be pressed momentarily to exit the calibration routine. The calibration procedure should then be re-tried.

If the unit continues to fail calibration, factory default settings should be restored by powering down, then pressing the CALIBRATE button as power is re-applied. The calibration procedure should then be repeated.

NOTE: To exit the calibration routine at any time, the CALIBRATE button should be pressed momentarily.

Data sheet
REE analogue interface

Input signals

REE interfaces are designed to be used with industry standard 1 Vpp readheads. Cos (V_1), Sin (V_2) and reference mark (V_0) differential input signals should have nominal signal amplitude of 1 Vpp developed across 120R input termination resistor. One or two open collector limit switch signals, active high or active low can also be input.

15 way 'D' type socket

Pin number	Signal name	Description
1	V_{1-}	Cosine -ve
2	V_{2-}	Sine -ve
3	V_{0+}	Reference mark +ve
4	5 V	5 V power supply
5	5 V	5 V power supply
6	–	Not connected
7	V_x/V_p	Setup signal/second (P) limit switch on dual limit readheads
8	V_q	First (Q) limit switch
9	V_{1+}	Cosine +ve
10	V_{2+}	Sine +ve
11	V_{0-}	Reference mark -ve
12	0 V	0 V power supply
13	0 V	0 V power supply
14	–	Do not connect
15	Inner	Cable's inner shield connection to 0 V

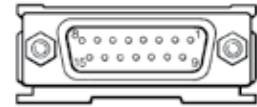

REE input

Output signals

15 way 'D' type plug

Pin number	Signal name	Description
1	V_{1-}	Cosine -ve
2	V_{2-}	Sine -ve
3	V_{0+}	Reference mark +ve
4	5 V	5 V power supply
5	5 V	5 V power supply
6	BID	Bi/uni-directional reference mark select
7	V_x/V_p	Setup signal/P limit switch on dual limit readheads
8	V_q	Q limit switch
9	V_{1+}	Cosine +ve
10	V_{2+}	Sine +ve
11	V_{0-}	Reference mark -ve
12	0 V	0 V power supply
13	0 V	0 V power supply
14	DIR	Direction selector for reference mark
15	–	Not connected

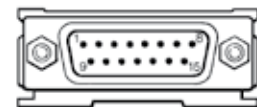

REE output

Output specifications

Analogue output signals - type REE 0000 Form - 1 Vpp differential

Incremental 2 channels V_1 and V_2 differential sinusoids in quadrature (90° phase shifted)

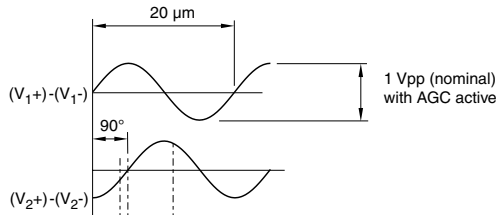

Reference

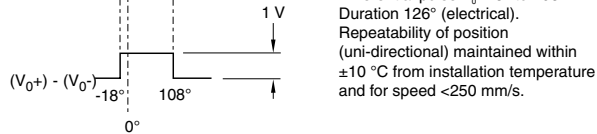

NOTE: The set-up LED on the REE interface cannot be used for reference mark set-up. Only the readhead LED (on Renishaw readheads) should be used for this purpose.

Limit RGH22, RGH40 and RGH41 only
Open collector output

Single limit

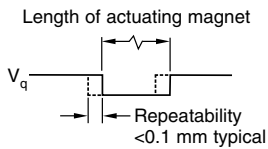

Asynchronous pulse Q

Dual limit

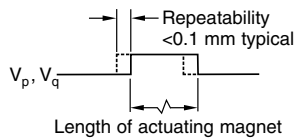

Asynchronous pulse P, Q

Set-up

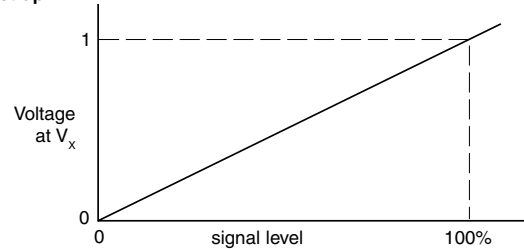

Setup signal voltage proportional to signal amplitude

Recommended signal termination

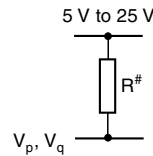
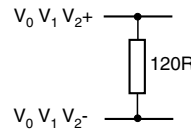

#Select R so that the maximum current does not exceed 20 mA. Alternatively use a relay or opto-isolator.
Actuation device A-9531-0251, A-9531-2052, A-9531-2054.

Electrical connections

Grounding and shielding

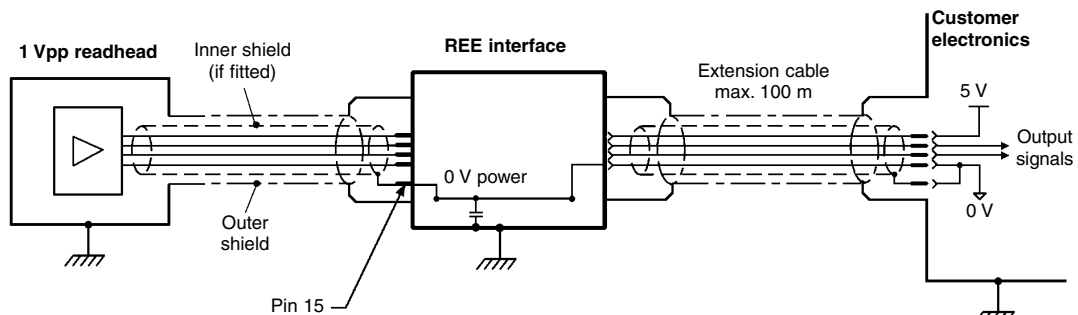

NOTE: Extension cable inner shield must be connected to 0V at customer electronics only

IMPORTANT: The outer shield should be connected to the machine earth (Field Ground). The inner shield should be connected to 0V. Care should be taken to ensure that the inner and outer shields are insulated from each other. If the inner and outer shields are connected together, this will cause a short between 0V and earth, which could cause electrical noise issues.

EMC compliance

The REE interface conforms to the relevant harmonised European standards for electromagnetic compatibility as detailed below.

BS EN 61000 BS EN 55011

Patents

Features of Renishaw's encoder systems and similar products are the subjects of the following patents and patent applications:

US4959542	US4974962	US4926566
EP0383901	US5088209	JP2963926
EP0388453	US5063685	JP2837483
EP0514081	US5241173	JP3202316
EP0543513	US5302820	JP5248895
EP0748436	US5861953	EP826138B
US6051971	JP3676819	EP1094302
US6481115	US6588333 B1	EP1147377
JP2003-512,611	US6772531	GB2397040
CN1585685	WO 03/041905	JP2005-508,760
US2005-0079499	CN1620353	WO 03/061891
EP1469969	JP2005-515,077	US2005-0045586
EP1552251	WO 2004/008079	EP1552248
WO 2004/008076		

Further information

For further information relating to the installation of REE systems, see also related readhead installation guides.

These can be downloaded from our website

www.renishaw.com/encoder and are also available from your local representative.

This document may not be copied or reproduced in whole or in part, or transferred to any other media or language, by any means without the written prior permission of Renishaw.

The publication of material within this document does not imply freedom from the patent rights of Renishaw plc.

Disclaimer

Considerable effort has been made to ensure that the contents of this document are free from inaccuracies and omissions. However, Renishaw makes no warranties with respect to the contents of this document and specifically disclaims any implied warranties. Renishaw reserves the right to make changes to this document and to the product described herein without obligation to notify any person of such changes.

Interface part numbers

REE 0000 A 00 A

Options

A - Dual limit switch

B - Single limit switch

For worldwide contact details, please visit our main website at www.renishaw.com/contact

RENISHAW HAS MADE CONSIDERABLE EFFORTS TO ENSURE THE CONTENT OF THIS DOCUMENT IS CORRECT AT THE DATE OF PUBLICATION BUT MAKES NO WARRANTIES OR REPRESENTATIONS REGARDING THE CONTENT. RENISHAW EXCLUDES LIABILITY, HOWSOEVER ARISING, FOR ANY INACCURACIES IN THIS DOCUMENT.

RENISHAW® and the probe emblem used in the RENISHAW logo are registered trademarks of Renishaw plc in the UK and other countries. apply innovation is a trademark of Renishaw plc.

© 2007-2008 Renishaw plc All rights reserved Issued 0808



L - 9517 - 9320 - 01