

# OMP600 optical machine probe



## Specification

|  |                 |  |   |
|--|-----------------|--|---|
| <b>Principal application</b>   |                 | Workpiece inspection and job set-up on all sizes of machining centres and small to medium multi-tasking machines |   |
| <b>Transmission type</b>   |                 | 360° infra-red optical transmission  |   |
| <b>Compatible interfaces</b>   |                 | <b>Modulated</b><br>OMI-2, OMI-2T, OMI-2H, OMI-2C or OMM-2 / OMM-2C with OSI / OSI-D                             | <b>Legacy</b><br>OMI or OMM with MI 12  |
| <b>Operating range</b>   |                 | Up to 6 m (19.7 ft)  |   |
| <b>Recommended styli</b>   |                 | High modulus carbon fibre, lengths 50 mm (1.97 in) to 200 mm (7.88 in)   |   |
| <b>Weight (without shank)</b>  |                 | including batteries  | 1029 g (36.3 oz)  |
| <b>Switch-on / switch-off options</b>  |                 | Optical on →<br>Shank on →<br>Spin on →  | Optical off or timer off<br>Shank switch off<br>Spin off or timer off           |
| <b>Battery life</b><br>(2 × AA 3.6 V lithium-thionyl chloride)   | Standby life    | 800 days maximum dependent on switch-on / switch-off option  |   |
|  | Continuous life | <b>Modulated</b><br>380 hours maximum, dependent on switch-on / switch-off option.                               | <b>Legacy</b><br>410 hours maximum, dependent on switch-on / switch-off option. |
| <b>Sense directions</b>  |                 | ±X, ±Y, +Z   |   |
| <b>Unidirectional repeatability</b>  |                 | 0.25 µm (10 µin) 2σ – 50 mm stylus length <sup>1</sup><br>0.35 µm (14 µin) 2σ – 100 mm stylus length             |   |
| <b>X, Y (2D) form measurement deviation</b>  |                 | ±0.25 µm (10 µin) – 50 mm stylus length <sup>1</sup><br>±0.25 µm (10 µin) – 100 mm stylus length                 |   |
| <b>X, Y, Z (3D) form measurement deviation</b>   |                 | ±1.00 µm (40 µin) – 50 mm stylus length <sup>1</sup><br>±1.75 µm (70 µin) – 100 mm stylus length                 |   |
| <b>Stylus trigger force</b> <sup>2,3</sup><br>XY plane (typical minimum)<br>+Z plane (typical minimum) |                 | 0.15 N, 15 gf (0.54 ozf)<br>1.75 N, 178 gf (6.03 ozf)  |   |
| <b>Stylus overtravel force</b><br>XY plane (typical minimum)<br>+Z plane (typical minimum)             |                 | 3.05N, 311gf (10.98 ozf) <sup>4</sup><br>10.69 N, 1090 gf (38.51 ozf) <sup>5</sup>                               |   |
| <b>Probe feedrate (minimum)</b>  |                 | 3 mm/min (0.12 in/min) <sup>6</sup>  |   |
| <b>Environment</b>   |                 | IP rating  | IPX8, BS EN 60529:1992+A2:2013  |
|  |                 | IK rating (typical)  | IK01, BS EN 62262:2002+A1:2021 [for glass window]                               |
|  |                 | Storage temperature  | –25 °C to +70 °C (–13 °F to +158 °F)  |
|  |                 | Operating temperature  | +5 °C to +55 °C (+41 °F to +131 °F)   |

<sup>1</sup> Performance specification is tested at a standard test velocity of 240 mm/min (9.45 in/min) with a 50 mm carbon fibre stylus. Significantly higher velocity is possible depending on application requirements.

<sup>2</sup> Trigger force, which is critical in some applications, is the force exerted on the component by the stylus when the probe triggers. The maximum force applied will occur after the trigger point (overtravel). The force value depends on related variables, including measuring speed, machine deceleration and system latency. RENGAGE equipped probes offer ultra-low trigger forces when probing at low feedrates.

<sup>3</sup> These are the factory settings: manual adjustment is not possible.

<sup>4</sup> Stylus overtravel force in the XY plane occurs 70 µm (2755.91 µin) after the trigger point and rises by 0.1 N/mm, 10 gf/mm (9.1 ozf/in) until the machine tool stops (in the high force direction and using a 50 mm (1.97 in) carbon fibre stylus).

<sup>5</sup> Stylus overtravel force in +Z direction occurs 10 µm (393.70 µin) to 11 µm (433.07 µin) after the trigger point and rises by 1.2 N/mm, 122 gf/mm (109.6 ozf/in) until the machine tool stops.

<sup>6</sup> Speeds below 3 mm/min commonly occur when manually moving the probe using the handwheel with a very fine feedrate.

For further information and the best possible application and performance support, contact Renishaw or visit

[www.renishaw.com/OMP600](http://www.renishaw.com/OMP600)

**OMP600 dimensions**

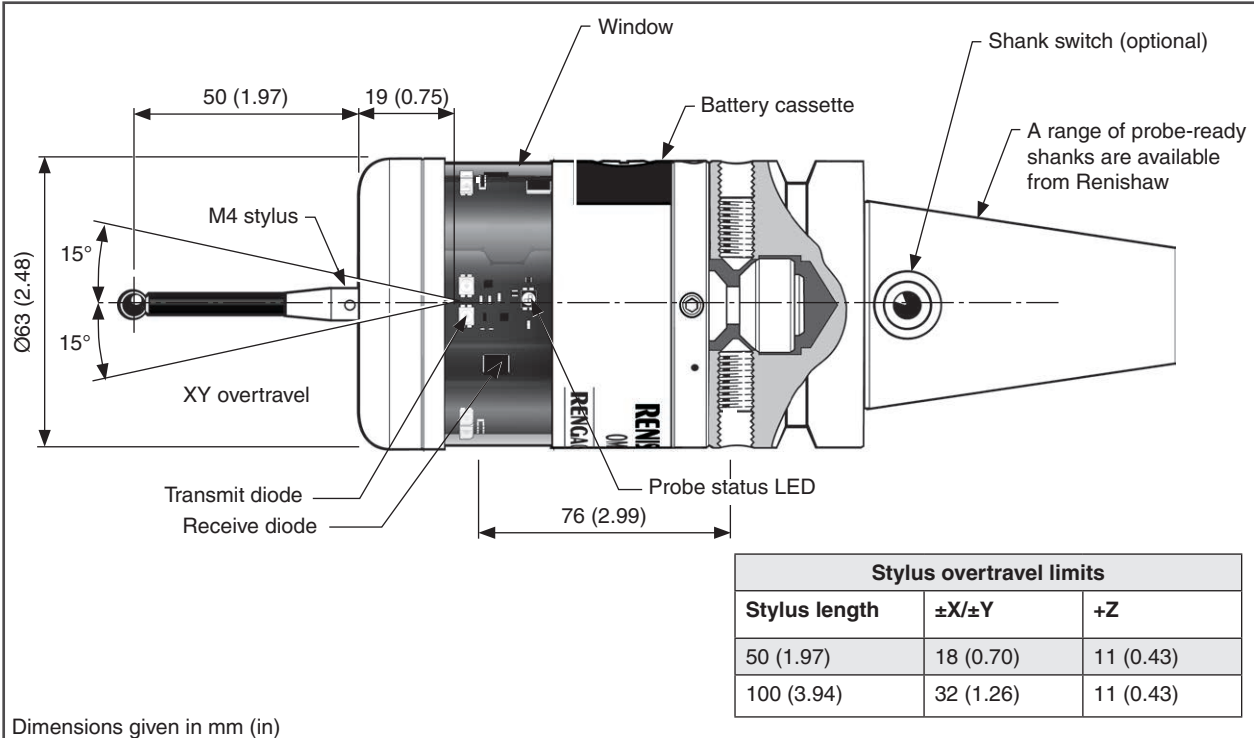

**Installing the OMP600 with OMI-2, OMI-2T, OMI-2H interface, or OMM-2 receiver with OSI / OSI-D interface**

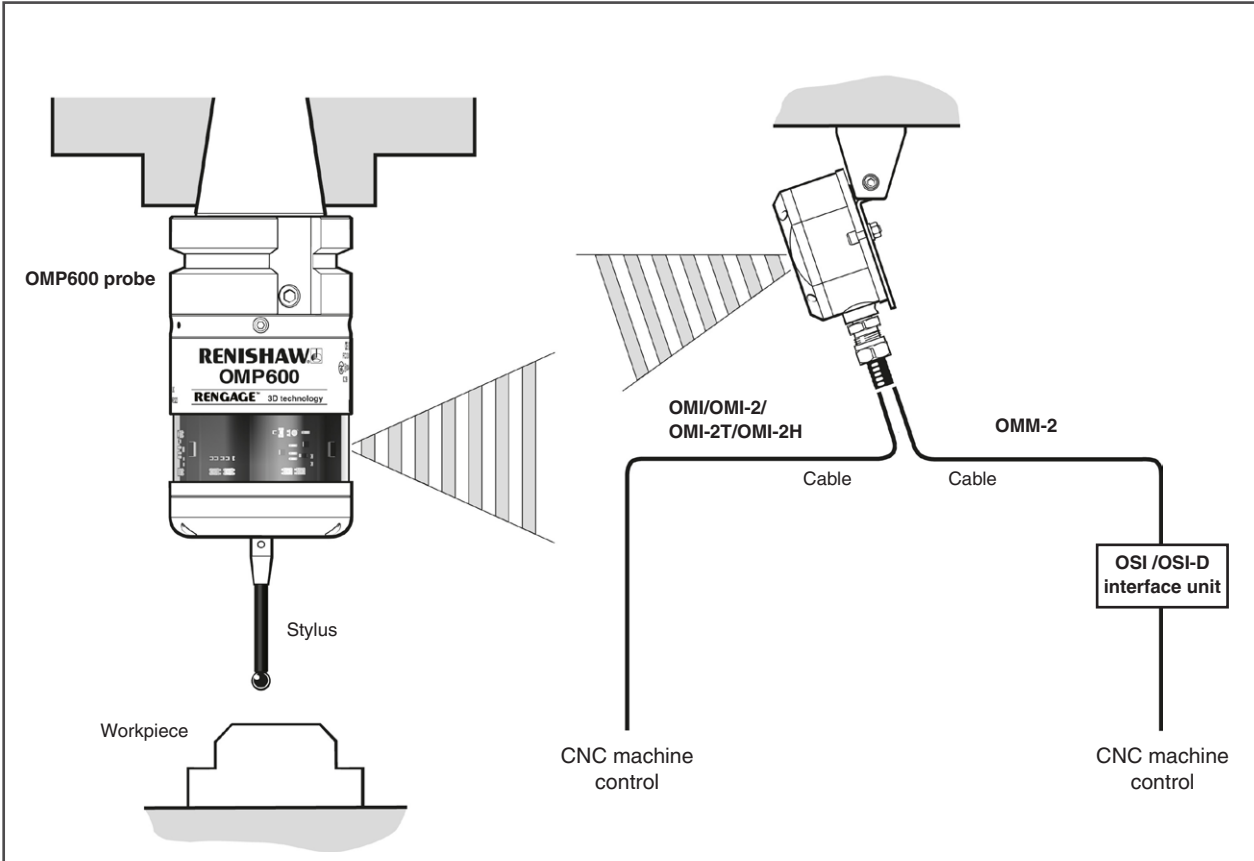

**Performance envelope when using the OMP600 with OMI-2, OMI-2T, OMI-2H interface, or OMM-2 receiver (modulated transmission)**

The OMP600 has a 360° transmission envelope over the ranges shown below.

The probe system should be positioned so that the optimum range is maintained over the full travel of the machine axes.

The OMP600 and optical receivers may deviate from the optical centre line, provided opposing light cones always overlap, with transmitters and receivers in the other's field of view (line of sight).

Natural reflective surfaces within the machine may improve the signal transmission range.

Coolant residue accumulating on the receiver will have a detrimental effect on transmission performance. Wipe clean as often as necessary to maintain unrestricted transmission.

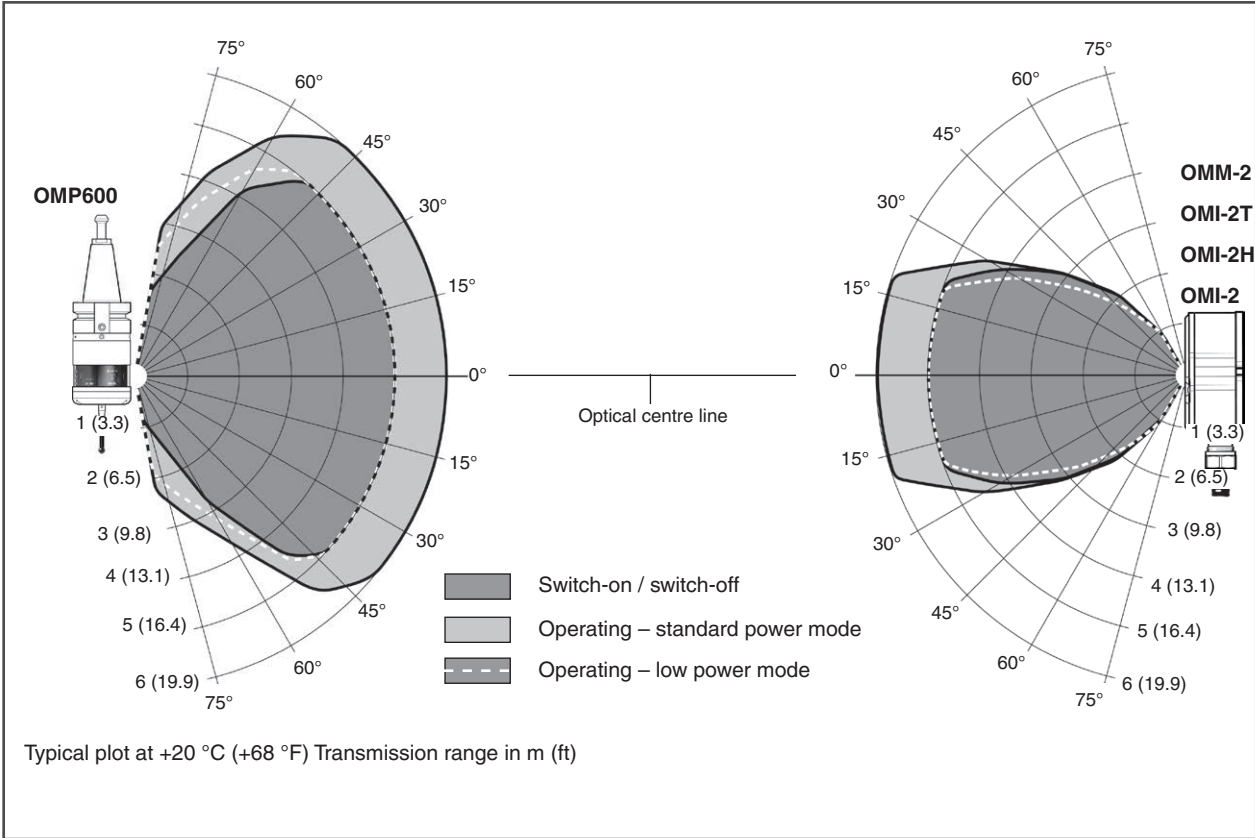

### Installing the OMP600 with an OMM-2C receiver with OSI / OSI-D interface

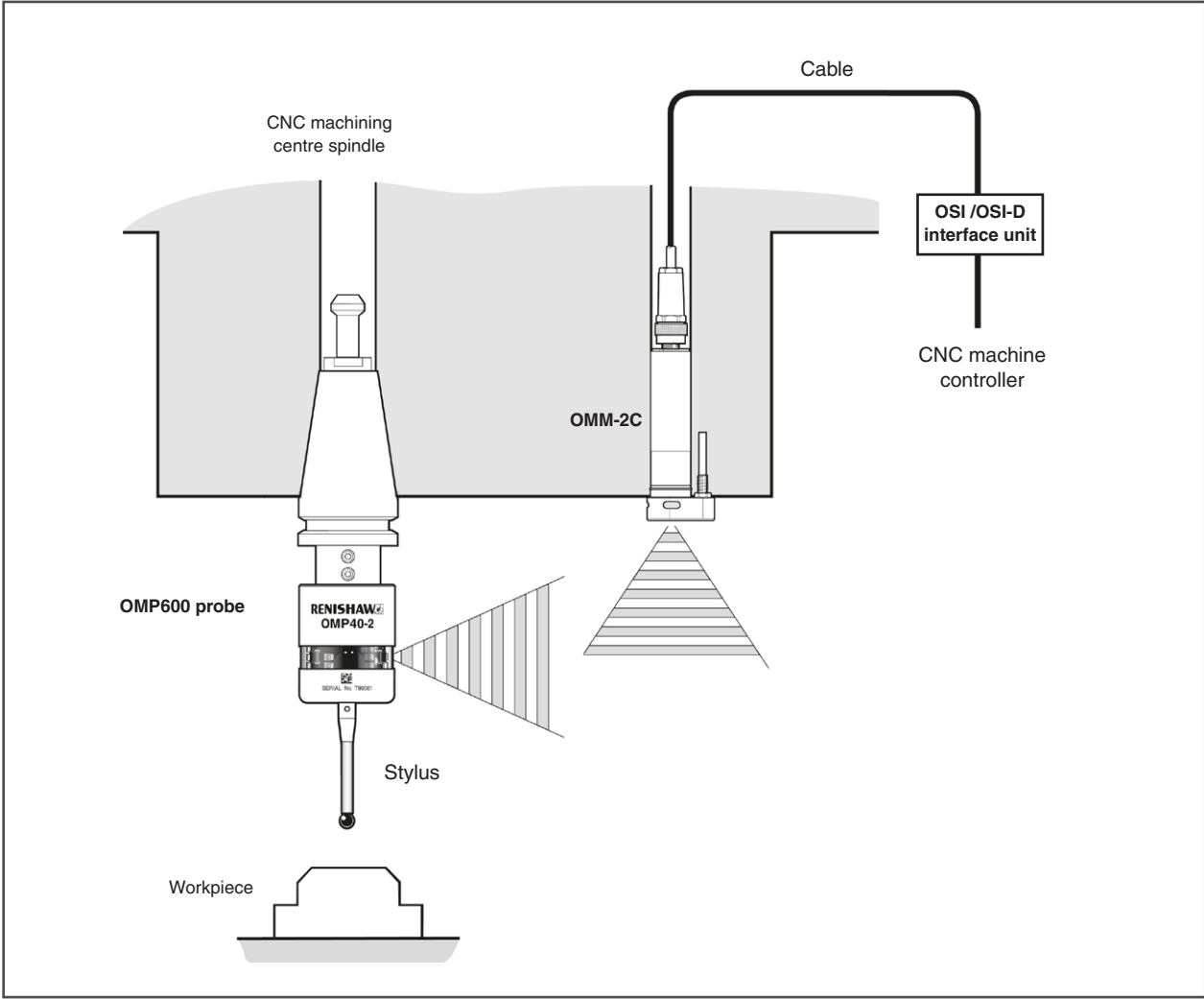

## Performance envelope when using the OMP600 with an OMM-2C receiver with OSI / OSI-D interface (modulated transmission)

**WARNING:** Ensure the machine tool is in a safe condition and power is removed before removing covers. Only qualified persons should adjust switches.

The OMM-2C receiver with OSI / OSI-D interface should be mounted as near to the machine spindle as possible.

When mounting the OMM-2C receiver, it is important that the sealing ring forms a tight seal around the rim of the bore into which the body of the OMM-2C receiver is to be located.

The diodes of the OMP600 and the OMM-2C receiver with OSI / OSI-D interface must be in each other's field of view and within the performance envelope shown. The OMP600 performance envelope is based on the optical centre line of the OMM-2C receiver with OSI / OSI-D interface being at 0° and vice versa.

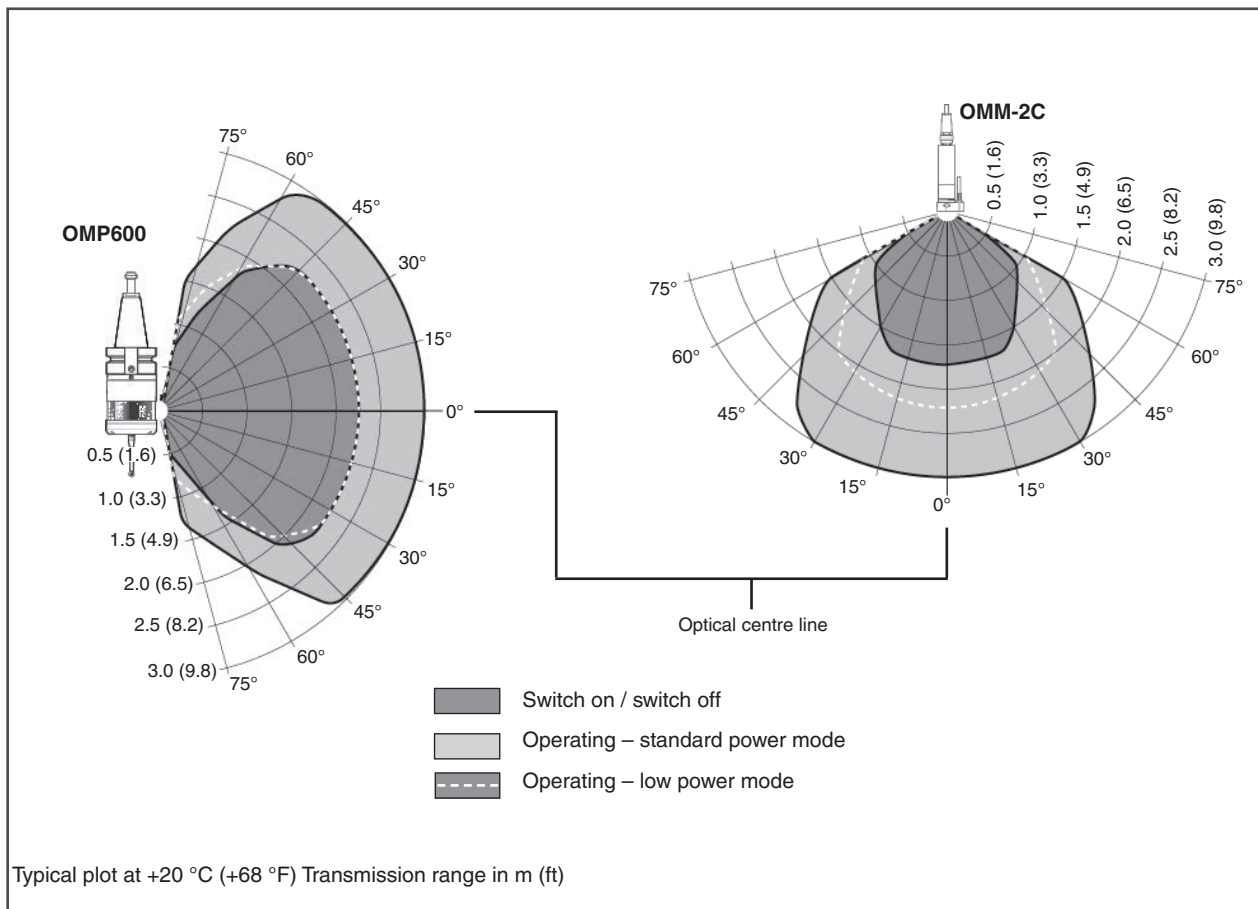

## Spare parts and accessories

A full range of spare parts and accessories is available. Contact Renishaw for a full list.

[www.renishaw.com/omp600](http://www.renishaw.com/omp600)

#renishaw

+44 (0) 1453 524524

uk@renishaw.com

© 2015-2024 Renishaw plc. All rights reserved. This document may not be copied or reproduced in whole or in part, or transferred to any other media or language by any means, without the prior written permission of Renishaw.

RENISHAW® and the probe symbol are registered trade marks of Renishaw plc. Renishaw product names, designations and the mark 'apply innovation' are trade marks of Renishaw plc or its subsidiaries. Other brand, product or company names are trade marks of their respective owners.

WHILE CONSIDERABLE EFFORT WAS MADE TO VERIFY THE ACCURACY OF THIS DOCUMENT AT PUBLICATION, ALL WARRANTIES, CONDITIONS, REPRESENTATIONS AND LIABILITY, HOWSOEVER ARISING, ARE EXCLUDED TO THE EXTENT PERMITTED BY LAW. RENISHAW RESERVES THE RIGHT TO MAKE CHANGES TO THIS DOCUMENT AND TO THE EQUIPMENT, AND/OR SOFTWARE AND THE SPECIFICATION DESCRIBED HEREIN WITHOUT OBLIGATION TO PROVIDE NOTICE OF SUCH CHANGES.

Renishaw plc. Registered in England and Wales. Company no: 1106260. Registered office: New Mills, Wotton-under-Edge, Glos, GL12 8JR, UK.

Part no.: H-5180-8200-02-A  
Issued: 04.2024