

OLP40 optical lathe probe



Specification

Principal application		Workpiece inspection and job set-up on small to medium machining centres and small multi-tasking machines)	
Weight without shank (including batteries)		277 g (9.77 oz)	
Transmission type		360° infrared optical transmission (modulated or legacy)	
Recommended styli		Ceramic, lengths 50 mm (1.97 in) to 150 mm (5.91 in)	
Switch-on method / switch-off methods		Optical on → Optical off Optical on → Timer off	
Battery life (2 × ½ AA 3.6 V lithium-thionyl chloride)	Standby life	1500 days maximum, dependent on switch-on/switch-off option.	
	Continuous use	1350 hours maximum, dependent on switch-on/switch-off option.	
Operating range		Up to 5 m (16.4 ft)	
Compatible receiver / interface		Modulated OMI-2, OMI-2T, OMI-2H, OMI-2C or OMM-2 / OMM-2C with OSI / OSI-D	Legacy OMI or OMM with MI 12
Sense directions		±X, ±Y, +Z	
Unidirectional repeatability		1.00 µm (40 µin) 2σ ¹	
Stylus trigger force ^{2 3}			
XY low force		0.60 N, 61 gf (2.15 ozf)	
XY high force		0.97 N, 99 gf (3.49 ozf)	
Z		6.23 N, 635 gf (22.41 ozf)	
Maximum setting:			
XY low force		0.83 N, 85 gf (2.99 ozf)	
XY high force		1.60 N, 163 gf (5.76 ozf)	
Z		10.00 N, 1020 gf (35.97 ozf)	
Minimum setting:			
XY low force		0.30 N, 31 gf (1.08 ozf)	
XY high force		0.60 N, 61 gf (2.16 ozf)	
Z		4.00 N, 408 gf (14.39 ozf)	
Stylus overtravel force		XY plane +Z plane	±12.5° 6 mm (0.24 in)
Environment		IP rating	IPX8, BS EN 60529:1992+A2:2013
		IK rating	IK02 BS EN IEC 62262: 2002+A1:2021
		Storage temperature	-25 °C to +70 °C (-13 °F to +158 °F)
		Operating temperature	+5 °C to +55 °C (+41 °F to +131 °F)

¹ Performance specification is tested at a standard test velocity of 480 mm/min (18.9 in/min) with a 50 mm stylus. Significantly higher velocity is possible depending on application requirements.

² Trigger force, which is critical in some applications, is the force exerted on the component by the stylus when the probe triggers. The maximum force applied will occur after the trigger point (overtravel). The force value depends on related variables, including measuring speed and machine deceleration.

³ These are the factory settings; manual adjustment is not possible.

OLP40 dimensions

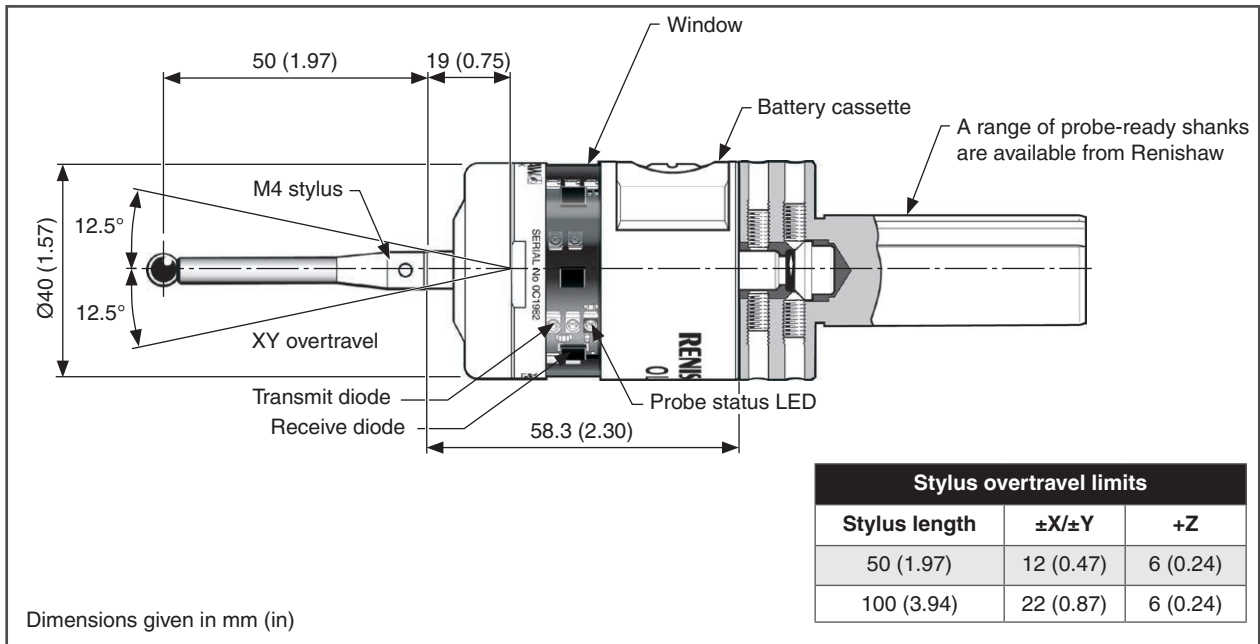

Installing the OLP40 with a OMI-2, OMI-2T, OMI-2H interface, or OMM-2 receiver with OSI / OSI-D interface

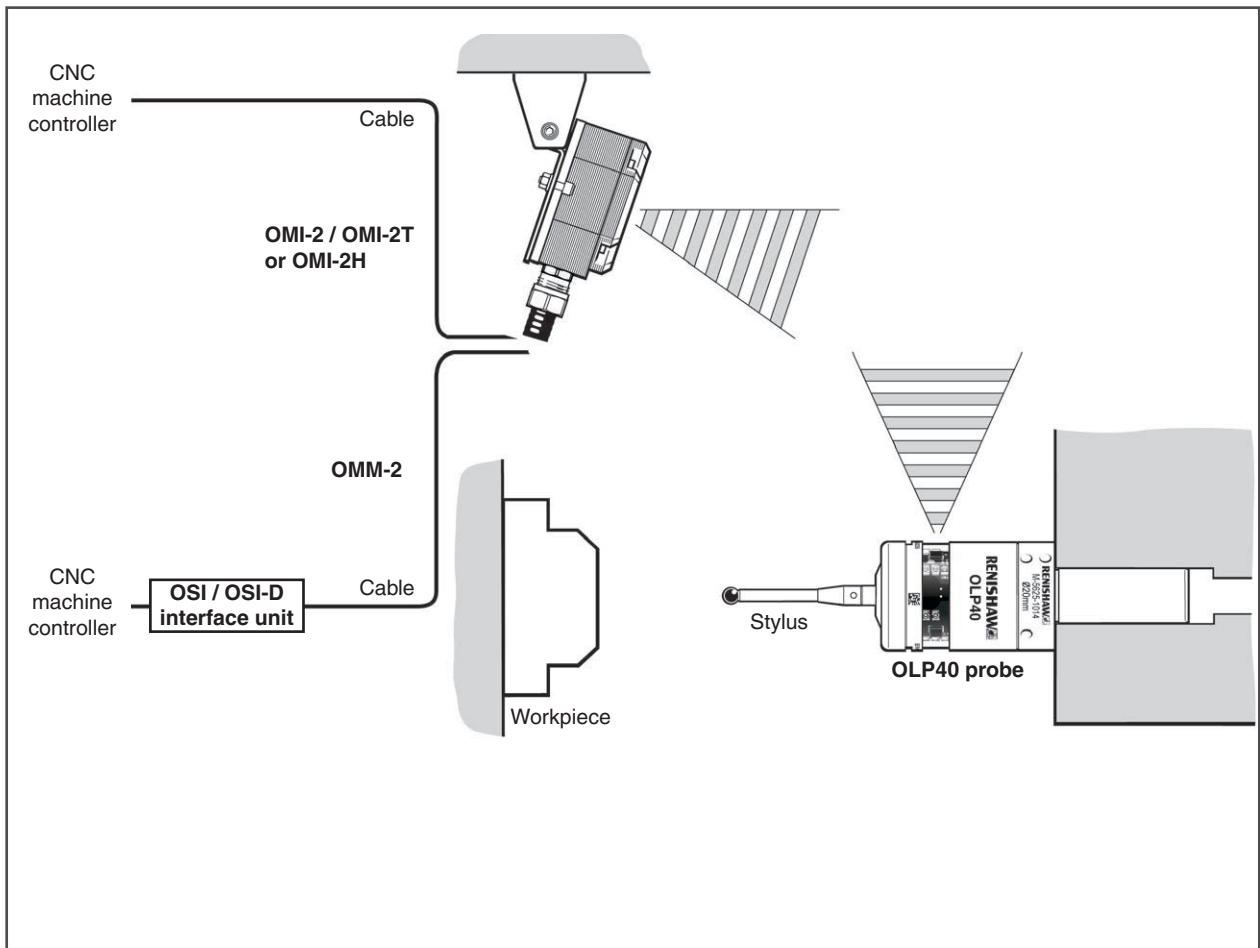

Performance envelope when using the OLP40 with a OMI-2, OMI-2T, OMI-2H interface, or OMM-2 receiver (modulated transmission)

The OLP40 has a 360° transmission envelope over the ranges shown below.

The probe system should be positioned so that the optimum range can be achieved over the full travel of the machine axis.

The OLP40 and optical receivers may deviate from the optical centre line, provided opposing light cones always overlap, with transmitters and receivers in the other's field of view (line of sight).

Natural reflective surfaces within the machine may affect the signal transmission range.

Coolant residue accumulating on the receiver will have a detrimental effect on transmission performance. Wipe clean as often as is necessary to maintain unrestricted transmission.

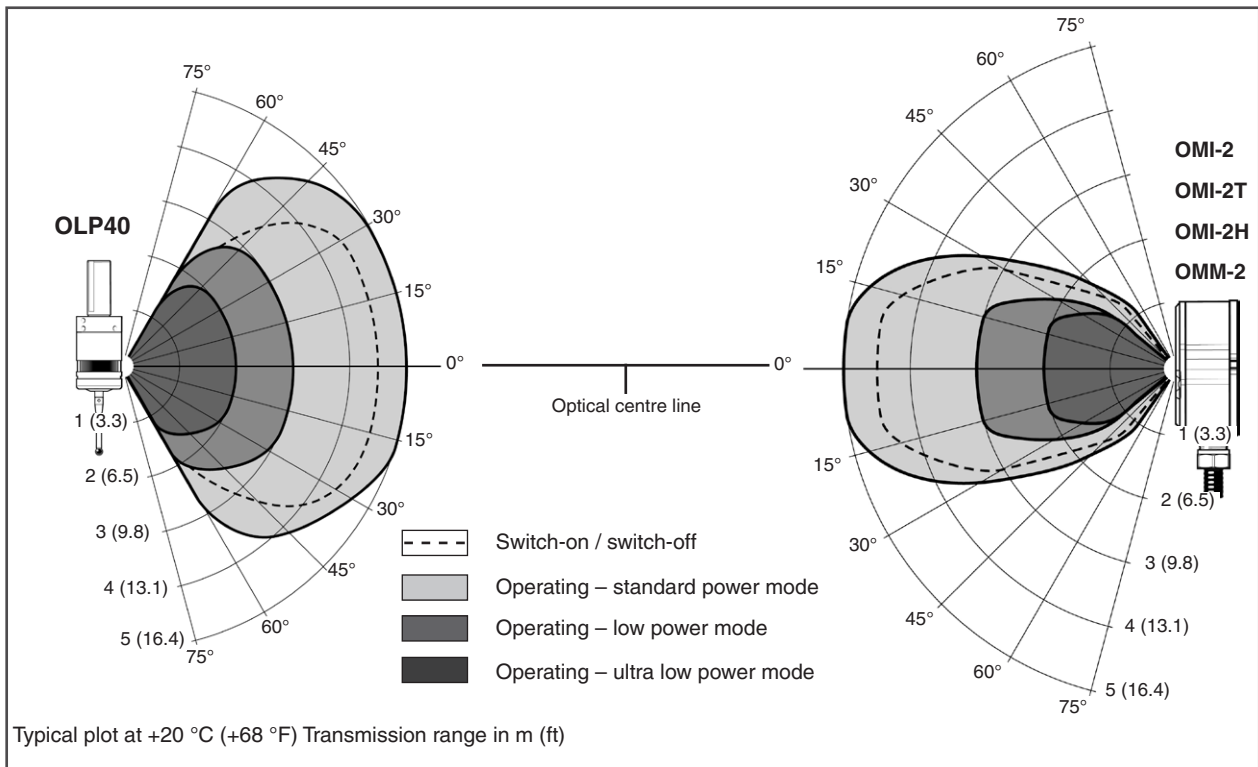

Installing the OLP40 with an OMM-2C receiver with OSI / OSI-D interface

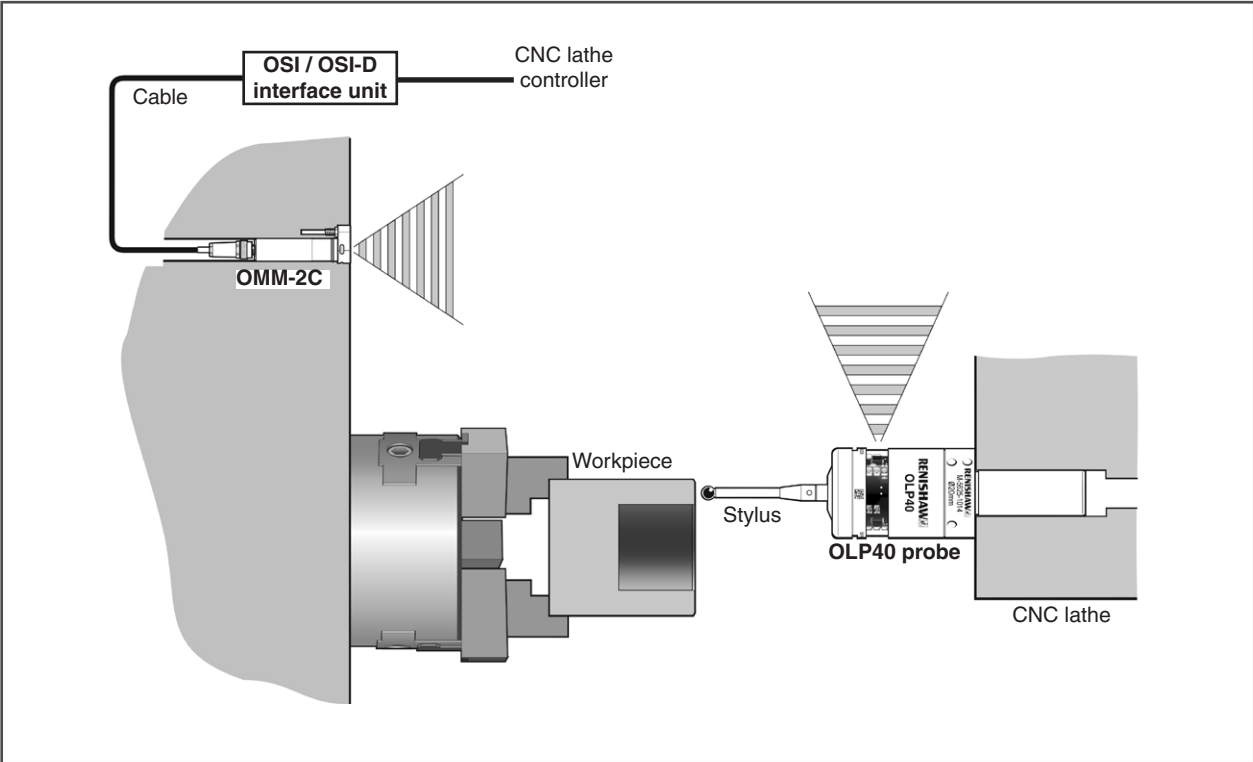

Performance envelope when using the OLP40 with a OMM-2C receiver with OSI / OSI-D interface

WARNING: Ensure the machine tool is in a safe condition and power is removed before removing covers. Only qualified persons should adjust switches.

The OMM-2C receiver should be mounted as near to the machine spindle as possible.

When mounting the OMM-2C receiver, it is important that the sealing ring forms a tight seal around the rim of the bore into which the body of the OMM-2C receiver is to be located.

The diodes of the OLP40 and the OMM-2C receiver must be in each other's field of view and within the performance envelope shown. The OLP40 performance envelope is based on the optical centre line of the OMM-2C receiver with OSI or OSI-D interface being at 0° and vice versa.

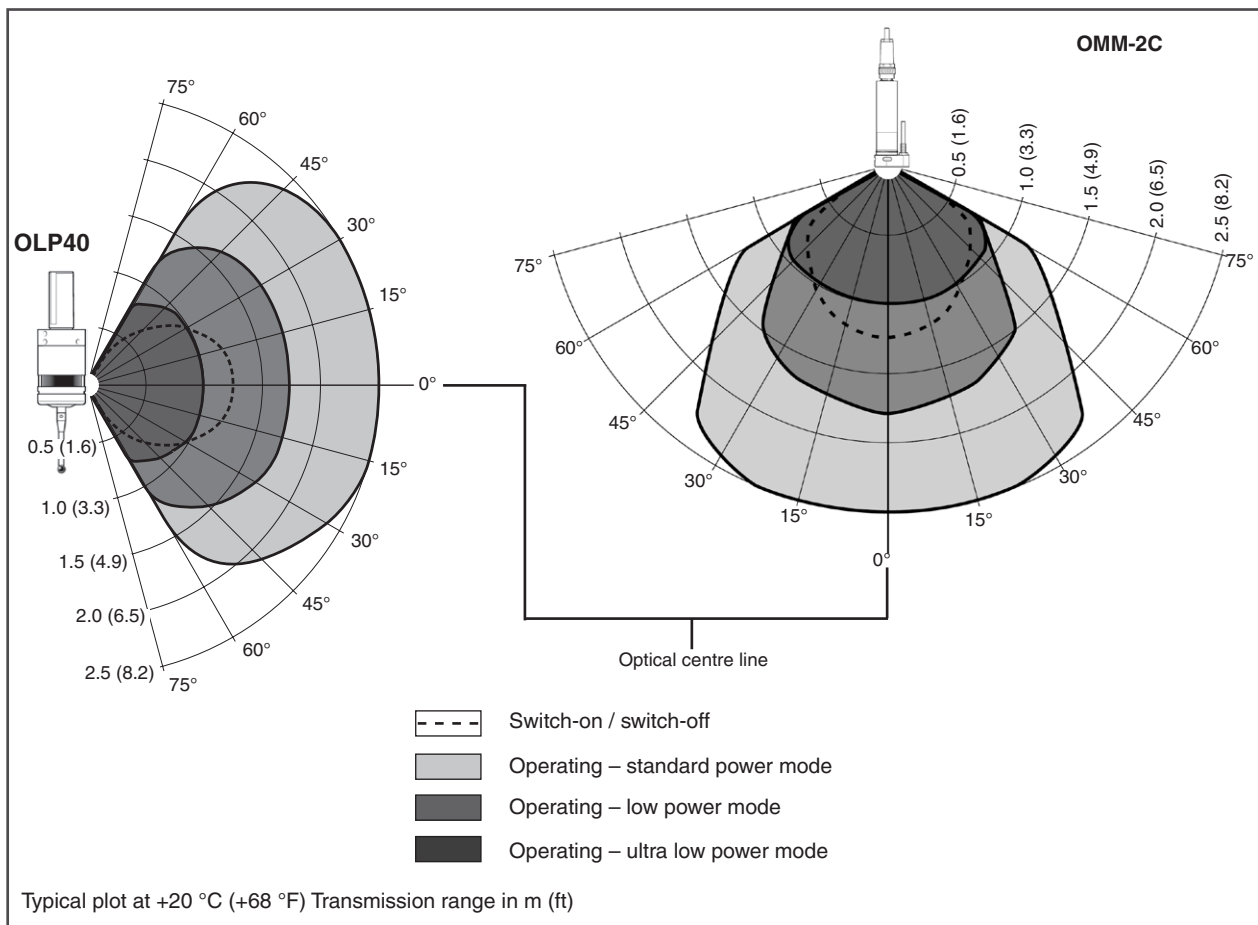

Spare parts and accessories

A full range of spare parts and accessories is available. Contact Renishaw for a full list.

www.renishaw.com/olp40

#renishaw

+44 (0) 1453 524524

uk@renishaw.com

© 2010–2024 Renishaw plc. All rights reserved. This document may not be copied or reproduced in whole or in part, or transferred to any other media or language by any means, without the prior written permission of Renishaw.

RENISHAW® and the probe symbol are registered trade marks of Renishaw plc. Renishaw product names, designations and the mark 'apply innovation' are trade marks of Renishaw plc or its subsidiaries. Other brand, product or company names are trade marks of their respective owners.

WHILE CONSIDERABLE EFFORT WAS MADE TO VERIFY THE ACCURACY OF THIS DOCUMENT AT PUBLICATION, ALL WARRANTIES, CONDITIONS, REPRESENTATIONS AND LIABILITY, HOWSOEVER ARISING, ARE EXCLUDED TO THE EXTENT PERMITTED BY LAW. RENISHAW RESERVES THE RIGHT TO MAKE CHANGES TO THIS DOCUMENT AND TO THE EQUIPMENT, AND/OR SOFTWARE AND THE SPECIFICATION DESCRIBED HEREIN WITHOUT OBLIGATION TO PROVIDE NOTICE OF SUCH CHANGES.

Renishaw plc. Registered in England and Wales. Company no: 1106260. Registered office: New Mills, Wotton-under-Edge, Glos, GL12 8JR, UK.

Part no.: H-5625-8200-05-A

Issued: 11.2024