

LTO2S / LTO2S-R systems for CNC lathes

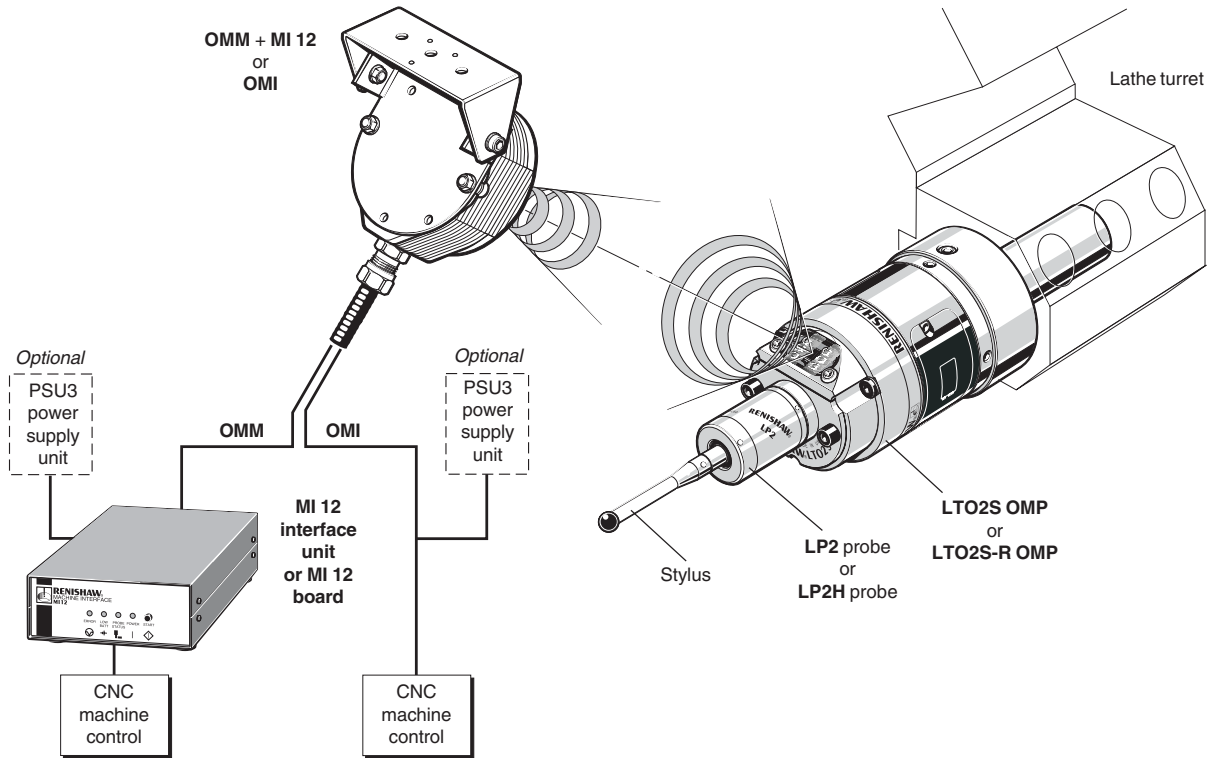

System features

- The LTO2S is suitable for medium and large machines.
- Easy to install as original equipment or retrofit.
- Exposed Renishaw components are fully sealed against coolant and hot metal chips.
- Optical housing made from steel.
- Optical windows made from toughened non-scratch material.
- Rapid job set-up and inspection.
- Automatic updating of work offsets.

System components

LTO2S OMP

The OMP receives and transmits optical signals. Power for probe operation is supplied by a battery. The OMP is sealed to IPX8 and designed for reliable operation in the machine tool environment.

LTO2S-R OMP

This is the visible red version of the LTO2S (for twin OMP installation only). The LTO2S-R OMP must be used with an OMMR and MI 12 to form a system.

OMM + MI 12

Signals pass from the CNC control to the OMP via the MI 12 and OMM and return along the same route. The MI 12 interface converts probe signals into the correct format for the CNC machine control input. OMM transmission and reception ranges are factory set to 100%. If OMM signals interfere with probes on other machines, the optical range can then be reduced.

OMI

This is an alternative to the OMM + MI 12 interface, combining the functions of both the OMM and MI 12 in one unit.

LP2 probe or LP2H probe

3D touch-trigger inspection probes ($\pm X$, $\pm Y$, $+Z$ directions). The LP2 is more sensitive than the LP2H, which is designed for heavier duty applications where vibration or heavy stylus arrangements cause spurious trigger signals.

PSU3 power supply unit for MI 12 or OMI

This is used when a +24 V supply is not available from the machine.

Extension bars and MA4 90° adaptor

Accessories provide greater access to workpiece features.

Software for probe routines

Renishaw single and double-touch probing cycles are available for use with Renishaw probing systems.

Note: Each system component is fully described on a separate data sheet – refer to the parts list on the back page.

Data sheet
LTO2S and LTO2S-R systems for CNC lathes

Dimensions in mm (in)

LTO2S OMP

The LTO2S OMP is mounted in a tool position on the lathe turret. Signal transmission and reception LEDs communicate with the OMM or OMI. Timeout and debounce time-setting switches are located inside the OMP.

For an explanation of terms and settings, see **System operation** on the page opposite.

LTO2S-R OMP

When a lathe is fitted with two optical signal transmission systems, problems with signal crosstalk between the two OMPs can occur. To prevent crosstalk, the second OMP should be an LTO2S-R visible red ('R') model.

Signals transmitted from an LTO2S-R are of a different optical frequency to those transmitted from a standard LTO2S model OMP.

LPE extension bars

Additional reach may be obtained by fitting an LPE extension bar between the LP2 probe and the LTO2S OMP.

Extension	Length mm (in)
LPE1	50 (1.96)
LPE2	100 (3.94)
LPE3	150 (5.90)

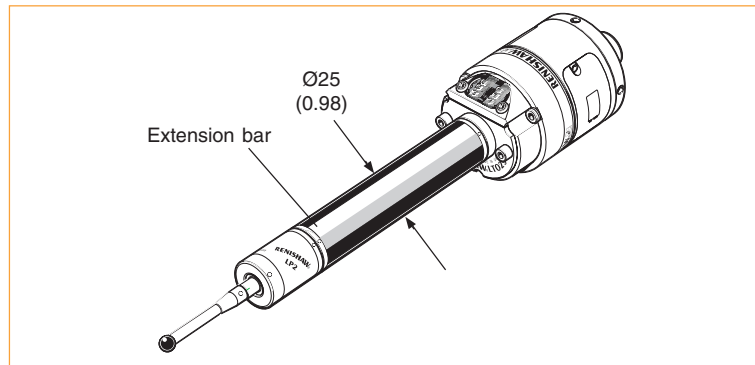
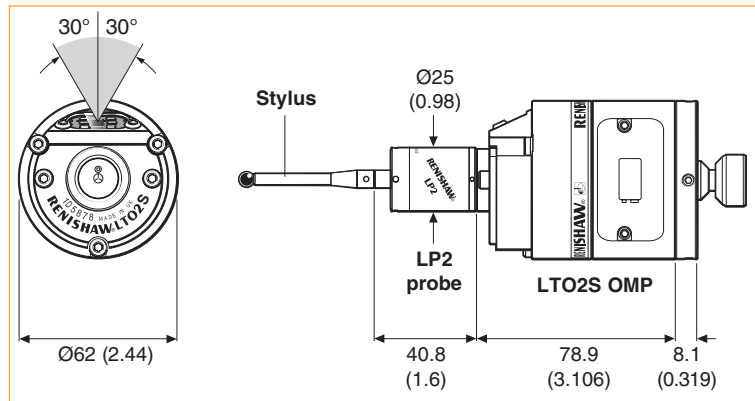

MA4 90° adaptor

The MA4 adaptor with M16 thread connects to the LTO2S OMP.

The LP2 mounts on the MA4 at 90° to the OMP centre line and can be set in any position through 360° before being clamped in place with three set screws.

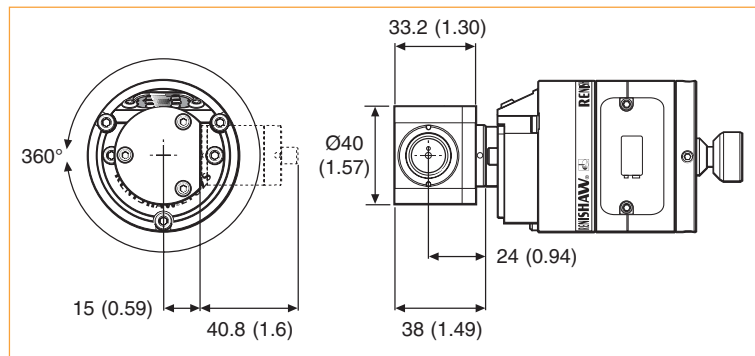

LTO2S mounting

To secure the LTO2S in the lathe turret, the LTO2S OMP is attached to a mounting adaptor. Two configurations are provided:

- Adjusting plate only
- Combination of adjusting plate and centre ball

Both configurations allow the stylus on-centre setting to be adjusted. Contact your local Renishaw office for details.

Adjusting plate only

This configuration allows the probe to slide across the shank end face. This is known as translational adjustment.

Adjusting plate and centre ball

This configuration allows the probe to slide across the shank end face and also pivot on the adaptor. This is known as translational and rotational adjustment. It is used in applications where the stylus stem must be parallel to the side of a bored hole or edge to avoid stem contact.

Signal transmission operating envelope

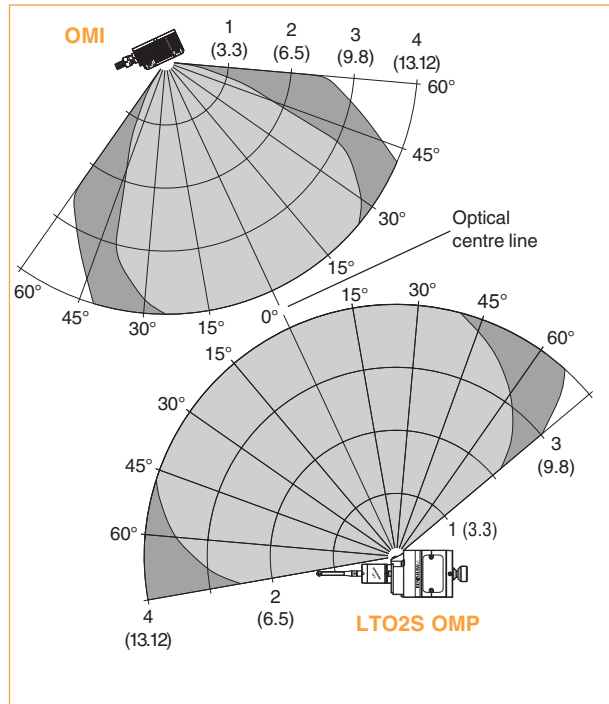
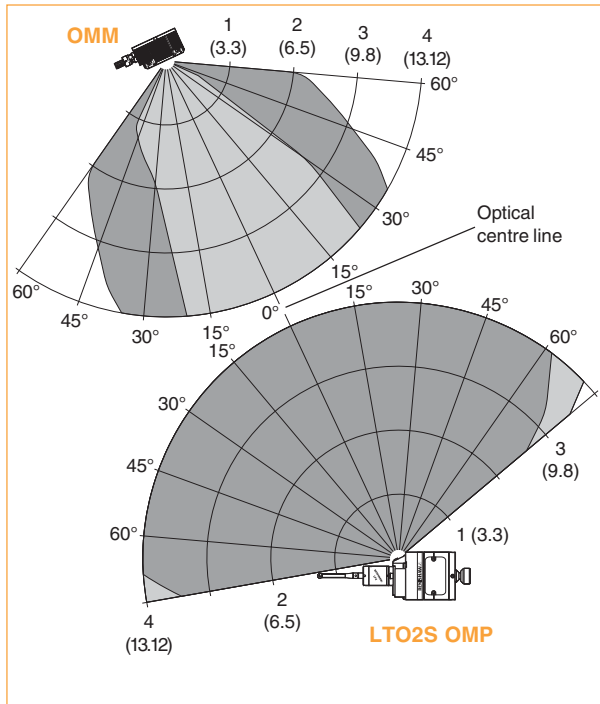

- SWITCH ON/OFF Range in metres (feet).
- OPERATING The OMP must be within 4 m (13.12 ft) of the OMM/OMI.

The LTO2S OMP and OMM/OMI diodes must be in the other's field of view, and within the performance envelope shown.

For the LTO2S-R, truncate the transmission plot to 2 m, as visible red light does not transmit as far as infrared. Use an OMMR instead of an OMM. The LTO2S-R cannot operate with an OMI.

System operation

Before using the LTO2S probe system, the program selected to 'drive' the probe must be verified. Incorrect programming may result in damage to the machine, workpiece and probe system.

LTO2S system: comprises an LTO2S, LP2 probe, stylus and either an OMM (one or two) and MI 12, or an OMI.

LTO2S-R system: comprises an LTO2S-R, LP2 probe, stylus and an OMMR (one or two) and MI 12.

The battery-powered LTO2S has two modes of operation:

1. Standby mode

To conserve battery life, the probe is held in standby mode until the CNC control sends a start signal, via the OMM or OMI, to the OMP receiving diodes. The start signal switches the probe to operating mode.

2. Operating mode

During the operating mode, probe signals are transmitted from the OMP transmitting LEDs to the OMM or OMI for onward transmission to the CNC control.

Probe switch-on options

The probe is switched on by one of the following methods:

- 1. Manual start** (*system with OMM + MI 12 only*)
Initiated by pressing the MI 12 manual start button.
- 2. Machine start** (*factory set to this option*)
(*system with OMM + MI 12 or system with OMI*)
Initiated by an M-code generated by the program.
- 3. Auto start** (*system with OMM + MI 12 or system with OMI*)
Initiated by an auto start signal sent every second.

Probe switch-off options

The probe is switched off by one of the following methods:

- 1. Optical on/Timer off** (*factory set to this option*)
A timer automatically returns the probe to standby if the probe is not used for 33 or 134 seconds (*factory set to 134 seconds*).
- 2. Optical on/Optical off**
A second start signal is generated by a software M-code which switches the probe off after 5 or 9 seconds (*factory set to 9 seconds*).

Power supply for the probe

The LTO2S and LTO2S-R probe systems are powered by a 9 V alkaline battery (Duracell MN 1604 or equivalent). A system low battery LED will light up when the battery needs to be replaced.

Typical battery life				
Standby life	5% usage (72 minutes per day)		Continuous use	
	Optical on Optical off	Optical on Timer off	Optical on Optical off	Optical on Timer off
365 days	98 days	80 days	140 hours	110 hours

Parts list – please quote the part number when ordering equipment

Component	Part number	Description
LTO2S system kit	A-2030-0204	LTO2S OMP, LP2 probe, OMM, mounting bracket, MI 12 interface unit and PS3-1C 50 mm stylus
LTO2S system kit	A-2030-0213	LTO2S OMP, LP2H probe, OMM, mounting bracket, MI 12 interface unit and PS3-1C 50 mm stylus
LTO2S system kit	A-2115-0030	LTO2S OMP, LP2 probe, OMI, mounting bracket and PS3-1C 50 mm stylus
LTO2S system kit	A-2115-0031	LTO2S OMP, LP2H probe, OMI, mounting bracket and PS3-1C 50 mm stylus
LTO2S OMP	A-2030-0183	LTO2S OMP, battery, adaptor plate assembly, centring ball, probe tool kit and user's guide
LP2	A-2063-6098	LP2 probe complete with two C spanners and TK1 tool kit
LP2H	A-2064-0002	LP2H probe complete with two C spanners and TK1 tool kit
Battery	P-BT03-0001	9 V alkaline battery – Duracell MN 1604
Stylus	A-5000-3709	Ceramic PS3-1C stylus, 50 mm long with Ø6 ball
Extension bar	A-2063-7001	LPE1 – extension bar Ø25 x 50 mm long
Extension bar	A-2063-7002	LPE2 – extension bar Ø25 x 100 mm long
Extension bar	A-2063-7003	LPE3 – extension bar Ø25 x 150 mm long
MA4 adaptor	A-2063-7600	MA4 90° adaptor
OMM	A-2033-0576	OMM, complete with cable
OMI	A-2115-0001	OMI, complete with cable
MI 12	A-2075-0142	MI 12 interface unit

LTO2S-R (visible red) system only:

LTO2S-R OMP kit	A-2030-0193	LTO2S-R OMP, battery, adaptor plate assembly, centring ball, probe tool kit and user's guide
OMMR	A-2031-0181	Optical receiver for LTO2S-R system (use with MI 12)

Associated literature (refer to these publications for the part numbers of equipment used with the LTO2S system):

Stylus range	See brochure H-1000-3200
LP2 and LP2H probes	See data sheet H-2000-2100
Adaptors and extensions	See data sheet H-2000-2120
OMM	See data sheet H-2000-2275
MI 12 interface	See data sheet H-2000-2195
OMI	See data sheet H-2000-2285
PSU3 power supply	See data sheet H-2000-2200
Software	See data sheet H-2000-2289

**For worldwide contact details, please visit our main web site at
www.renishaw.com/contact**