

# High-accuracy laser tool setting systems

**RENISHAW**   
NC4+ BLUE F230C-R

Non-contact tool setting

# Flexible family of high-accuracy non-contact tool setting systems

Renishaw's range of NC4 non-contact tool setters provides high-precision, high-speed tool measurement and broken tool detection, allowing process control on all sizes and types of machine tools.

During machining processes, dimensional accuracy is dependant upon several variables, including tool size deviation, tool run-out and tool breakage.

Renishaw's NC4 systems allow users to control these variables, enabling measurement of a wide variety of tools at production feeds and speeds, while minimising the risk of excessive tool wear or tool breakage – an important consideration for small and fragile tools.

Measurements are fast and accurate, allowing users to increase their productivity and machine utilisation while simultaneously reducing scrap and rework.

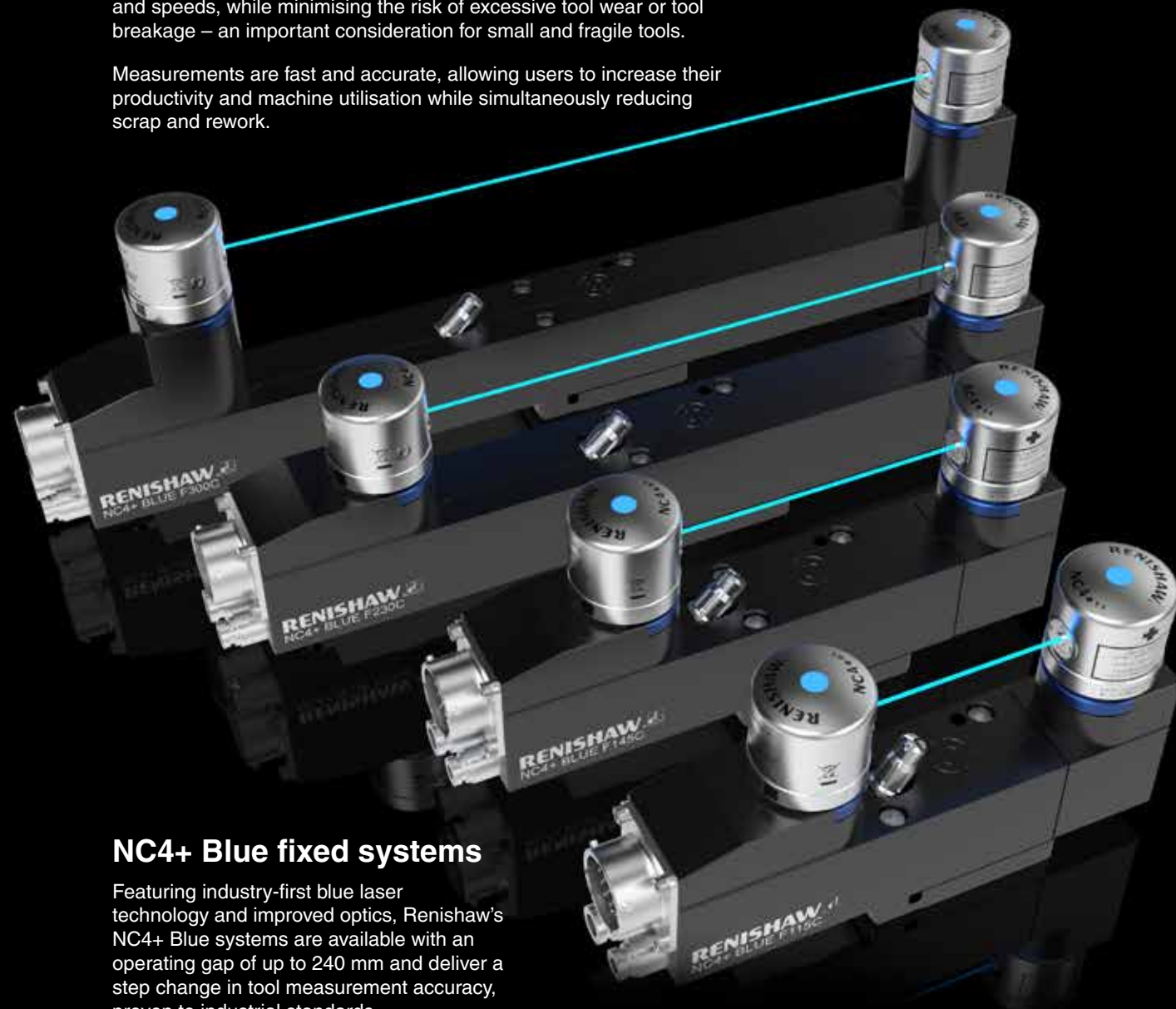

## NC4+ Blue fixed systems

Featuring industry-first blue laser technology and improved optics, Renishaw's NC4+ Blue systems are available with an operating gap of up to 240 mm and deliver a step change in tool measurement accuracy, proven to industrial standards.

All systems feature an integral air blast as standard to enable accurate and reliable tool measurement.



## NC4 separate systems

Renishaw's separate systems offer the same on-machine tool measurement and broken tool detection functionality as their fixed system counterparts.

Users can set these systems up in a range of configurations depending on the application – giving users the ultimate flexibility.

Separate systems are available with an operating gap of up to 5 m.

## Custom solutions

Renishaw provides bespoke NC4 systems to suit specific applications – including a range of sizes, mounting configurations and additional integrated probing systems; for example, contact tool setters for turning tools.



# System components

## Interface

The NCI-6 interface processes signals from the NC4 and converts them into voltage-free solid-state relay (SSR) outputs, for transmission to the CNC machine controller.



## Air preparation kit

Provides the NC4 with clean, dry air to protect it against coolant and swarf. Simple to install and no M-codes are required.

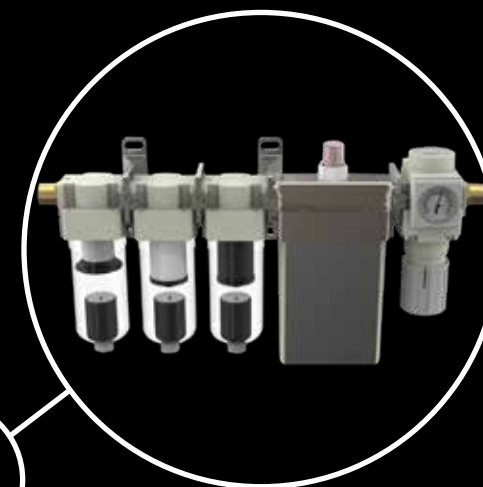

## Intuitive tool setting software

(see pages 18 and 19)



## NC4+ Blue non-contact tool setter

(see pages 2 and 3)



## Accessories

### NC4 set-up tool

The NC4 set-up tool, is a battery-operated device that allows users to quickly and easily set up and maintain their NC4 systems.

### Calibration tools

Calibration is essential for accurate tool measurement using non-contact tool setters. A ball-nosed calibration tool, which can be supplied by Renishaw, is recommended for calibration of the NC4.

### NC4 smartphone app

The NC4 smartphone app makes configuring and supporting the range of NC4 non-contact tool setters simple. Engineers have a single point of reference for configuration, maintenance and troubleshooting tasks at their fingertips.

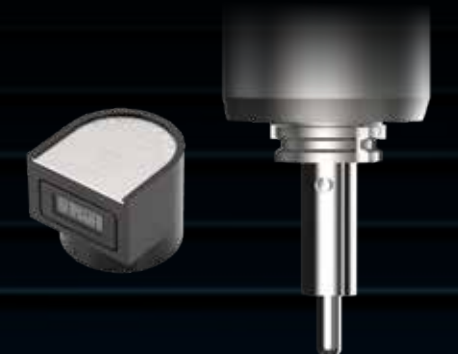

# The Productive Process Pyramid™

## Tackle process variation at source, and reap the rewards

The higher the degree of human involvement in the manufacturing process, the higher the risk of error. Automated in-process measurement using Renishaw probes can help eliminate the risk. Renishaw's range of NC4 non-contact tool setters can facilitate the following measures for enhanced management of your production, leading to an increase in your profits.

For further details regarding the benefits of all levels of process control within the Productive Process Pyramid™, visit [www.renishaw.com/processcontrol](http://www.renishaw.com/processcontrol).

“ The Renishaw NC4 system ensures product integrity, eliminates costly scrap, and also the possibility of a broken spindle, which would be hugely expensive to replace in such high-end machines.

Hope Technology (UK) ”

### Post-process monitoring

Renishaw offers a range of other systems which enable users to check their processes and finished parts against their specifications, as well as log process routes and outcomes.

For more information, visit [www.renishaw.com/postprocessmonitoring](http://www.renishaw.com/postprocessmonitoring)

### In-process control

Automated tool condition monitoring.

- Improve process capability and traceability
- Detect broken tools in-process
- Compensate for environmental and machine conditions
- Measure tool profiles
- Reduce non-productive time and scrap
- Increase productivity and profits

### Process setting

Automated on-machine tool setting eliminates manual setting operations.

- Establish height offsets and check tool length is within tolerance
- Determine diameter when spinning to establish tool size offsets
- Compensate for dynamic effects on the machine tool
- Eliminate manual setting errors and data entry
- Set up faster, improve quality and reduce scrap

### Process foundation

Renishaw offers a range of other systems which enable users to gain a greater understanding of their machines' capabilities and keep control of their performance.

For more information, visit [www.renishaw.com/processfoundation](http://www.renishaw.com/processfoundation)



# High-accuracy tool setting with blue laser technology

Non-contact laser tool setting systems use a beam of laser light, passing between a transmitter and a receiver, positioned within the machine tool so the cutting tools can be passed through the beam.

The passage of a tool into the beam causes a reduction in the amount of laser light being acquired by the receiver, and a trigger signal is generated. This records the machine position at that instant, providing the information to determine a tool's dimension.

With approaches from several directions, tool geometry can also be accurately determined. These systems can also be used to detect broken tools by rapidly moving the tool into a position where it should intersect the laser beam. If light reaches the receiver, the tool tip must be missing.

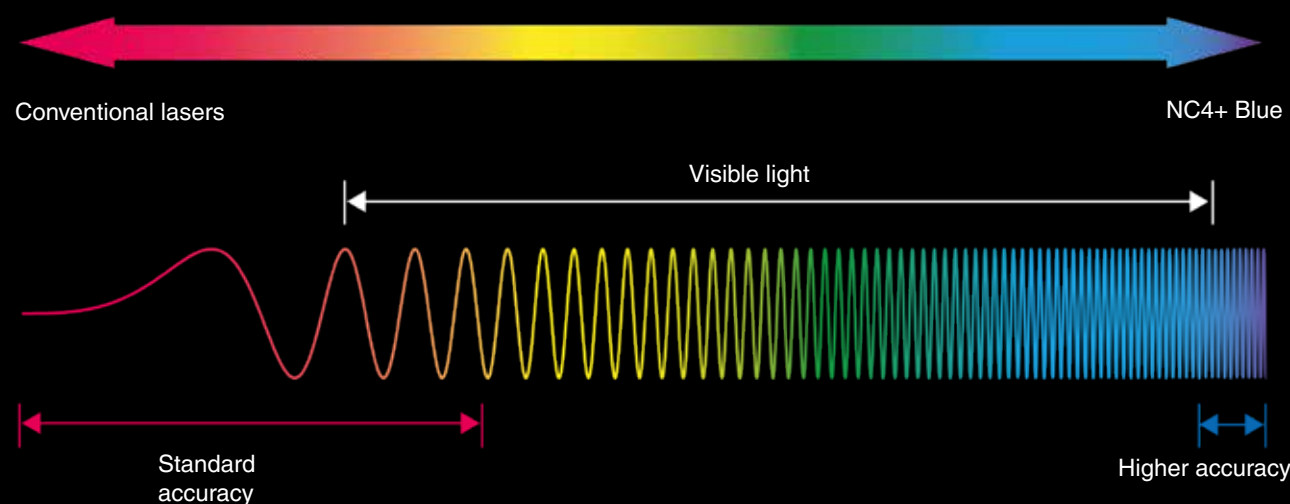
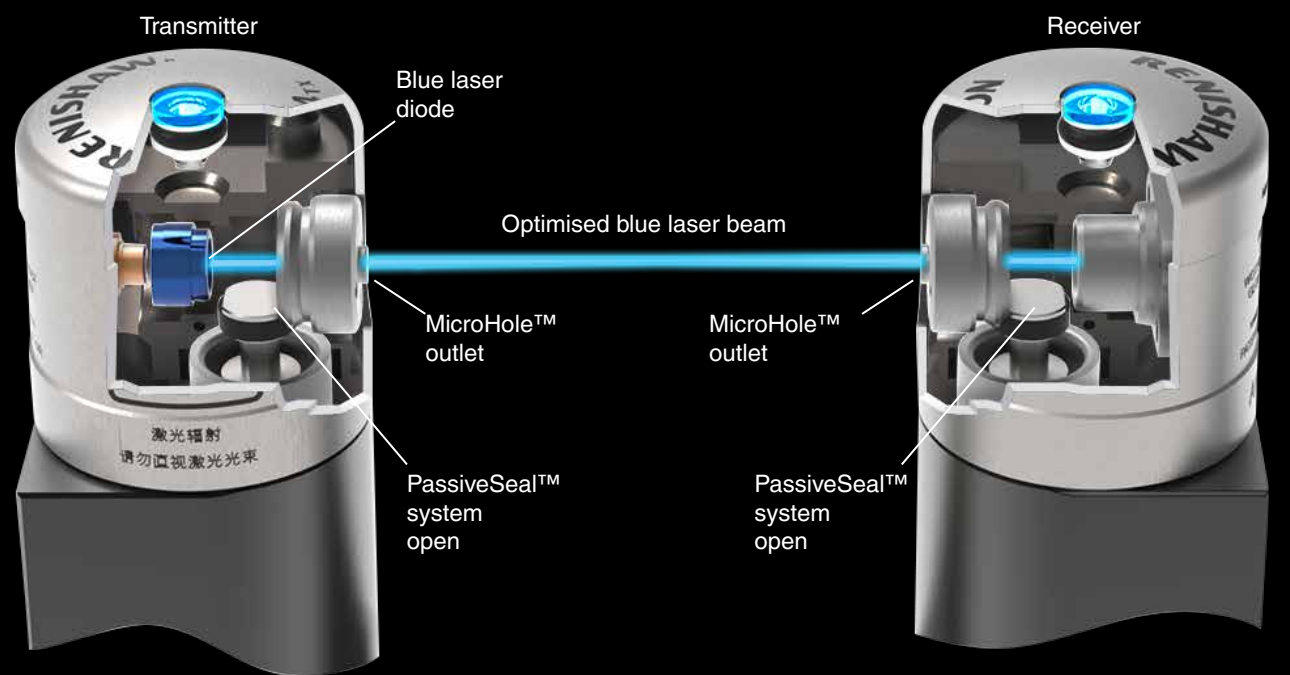

# Optimised for production environments

## Superior measurement accuracy

The improved measurement performance associated with blue lasers enables the measurement of very small tools, whilst minimising tool-to-tool measurement errors. Minimising these errors is also a critical consideration when machining with a wide range of cutting tools.

Tool measurements taken on NC4+ Blue systems closely reflect the true dimensions of the tool, giving users confidence in their manufacturing capabilities.

These factors enable users to manufacture complex components more accurately and efficiently than ever before.

### Small tool accuracy

Enabling the measurement of very small tools

### Tool-to-tool performance

Minimising tool-to-tool measurement variation across all types of tools

### Absolute accuracy

Ensuring measurements reflect the true dimensions

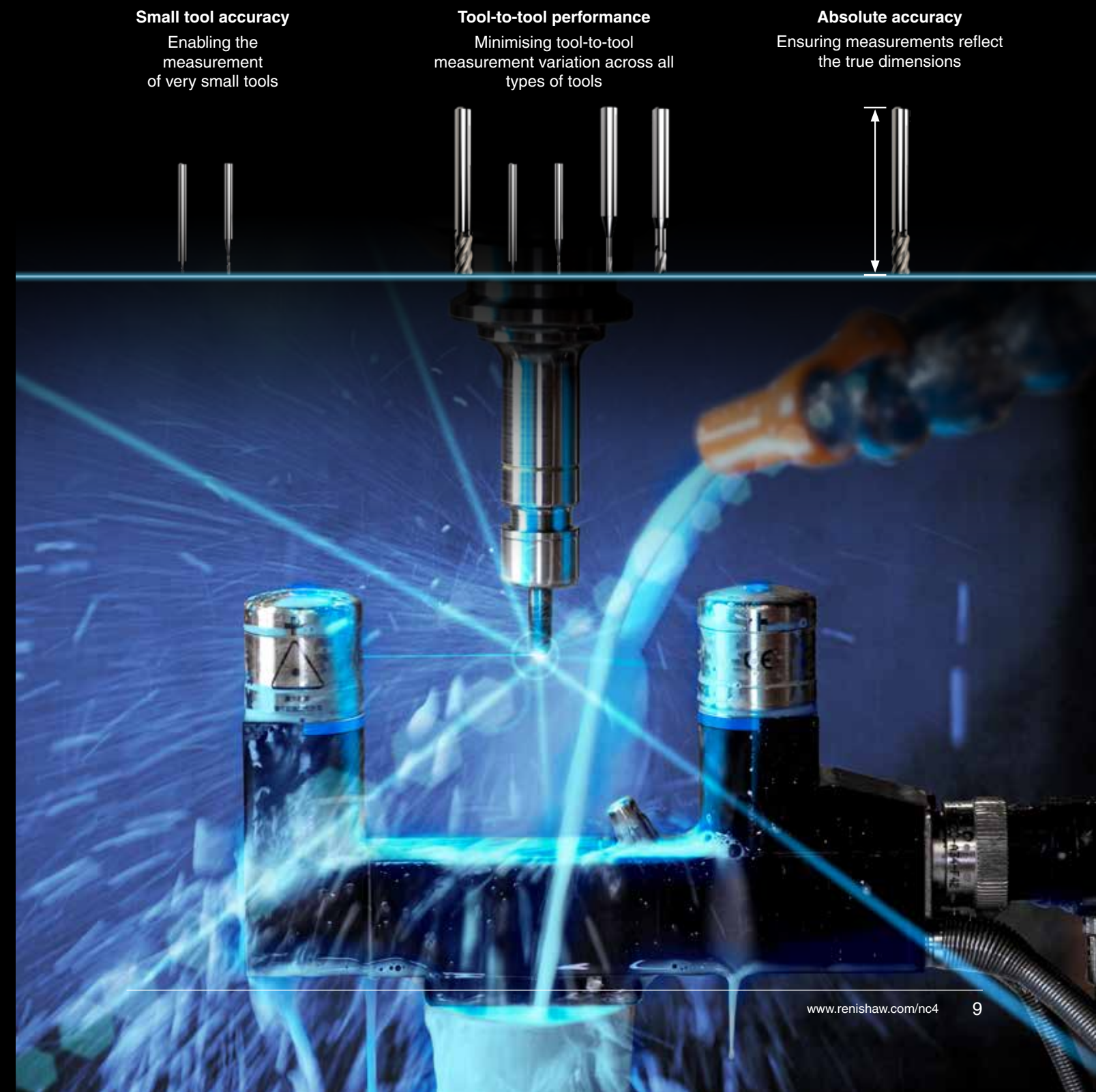



# Optimised measurement cycles

All Renishaw non-contact tool setters are supported by optimised on-machine software. This software features:

- Dual measurement mode – tools are measured as they are brought out of the beam, significantly improving out-of-the-box cycle time and robustness of measurements in wet conditions.
- Auto-optimisation technology – on-machine measurements are self-optimised for each CNC machine tool.

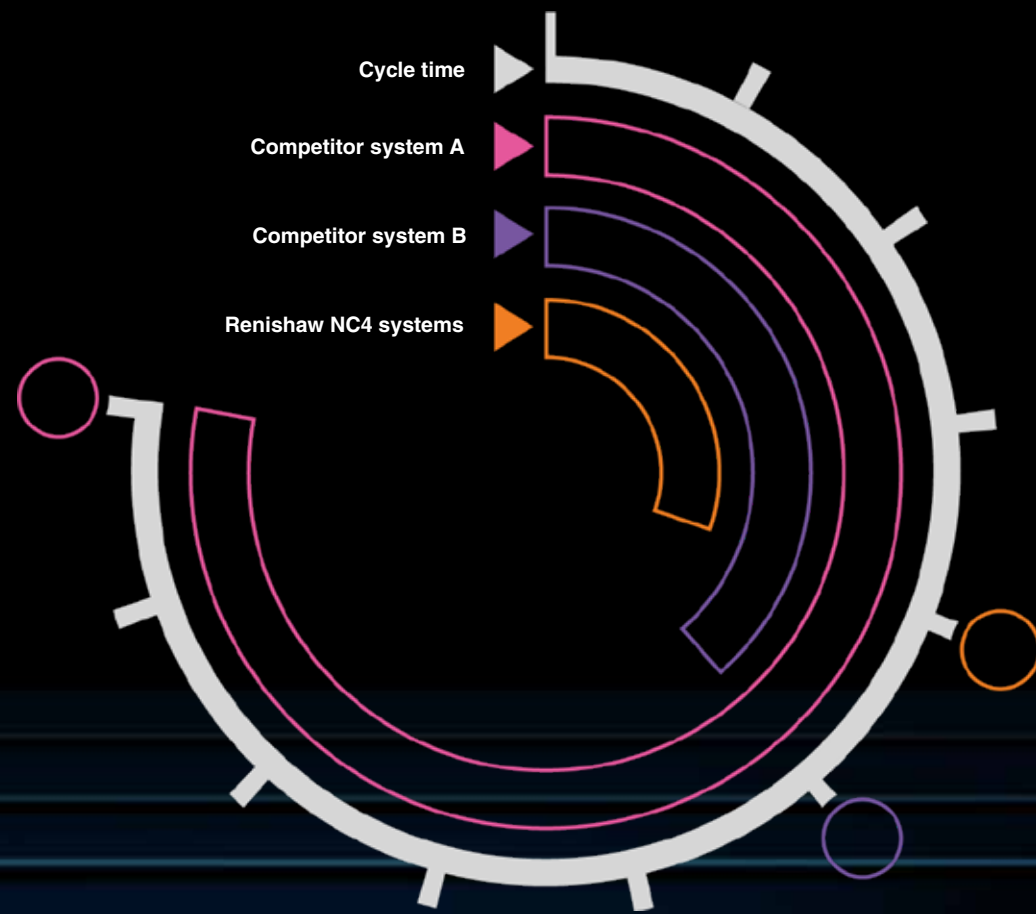

“ The NC4 allows us to check for breakages of small tools used to make keys and other reference points on the cam, which are vital if the engine is to operate properly. If it wasn't for the Renishaw system, the machine could operate with a broken cutting tip, with disastrous results.

Ducati (Italy) ”





# Superior optical protection system

Renishaw NC4 systems use a combination of smart environmental protection technologies to protect their precision optics. This ensures that systems remain functional, accurate and repeatable.

The NC4 systems use a simplified electrical and pneumatic installation, without mechanically moving parts or M-code requirements.

Renishaw's MicroHole™ technology features a continuous stream of compressed air through a very small and precise laser-drilled hole.

Air flows out of the MicroHole at over 250 m/s to counteract any potential ingress of coolant or debris, providing a protection system that operates under real machining conditions.

Renishaw's PassiveSeal™ system provides an additional layer of protection, preventing the contamination of optics if the air supply is shut off.

This combination ensures that NC4 systems are protected at all times.

PassiveSeal system  
in closed position

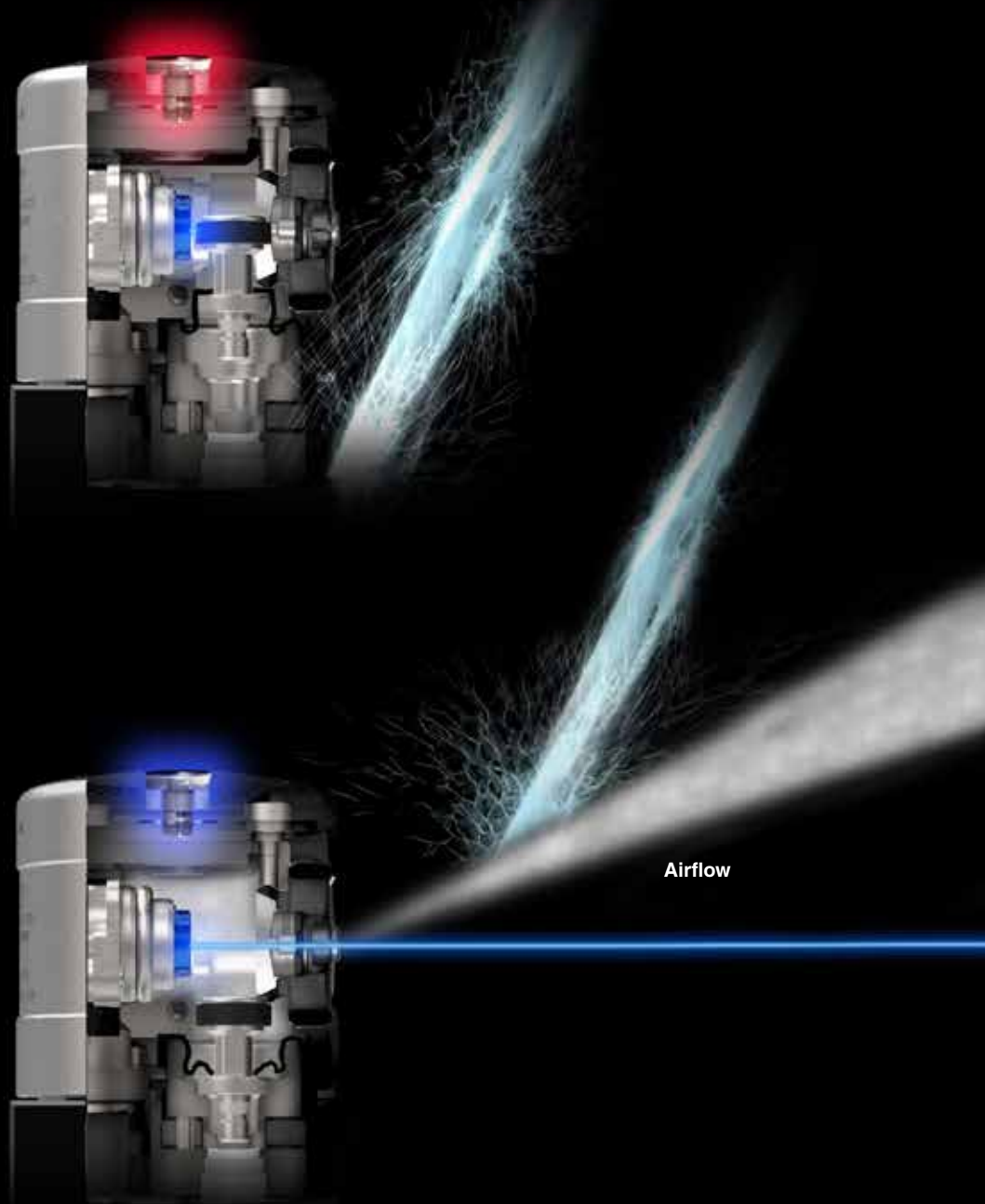

“ Renishaw has an excellent reputation in manufacturing industries, and also provides services for different industries, so it doesn't just offer a product or a solution, but also shares with us its experience, expertise and the industry's best practices. Renishaw is also meticulous in terms of its technical support, the Renishaw team reacts quickly to solve problems; this is particularly impressive to us.

SuperAlloy Industrial Company Ltd (Taiwan) ”

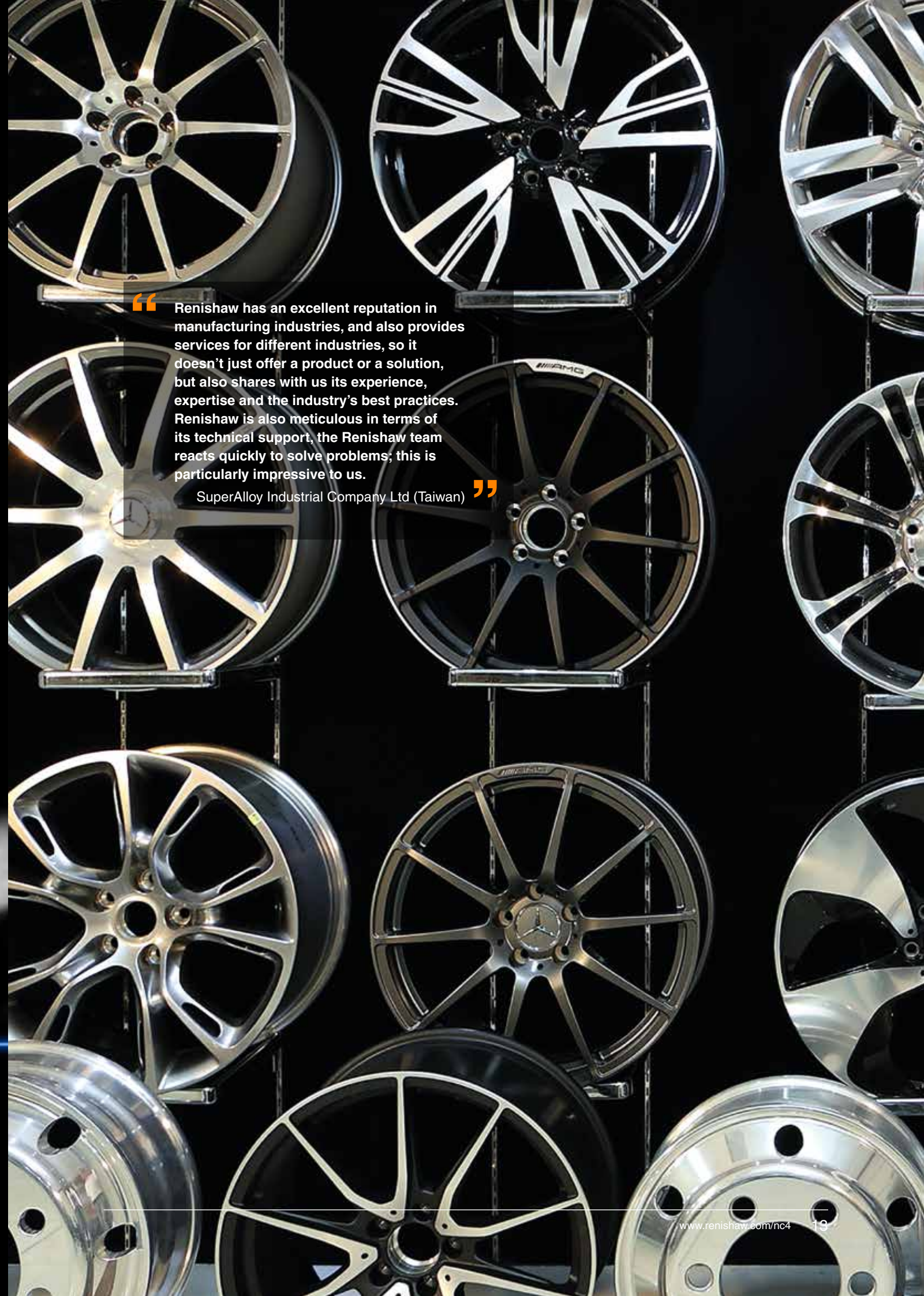



# NC4+ Blue fixed systems

Fixed systems offer the best tool setting and measurement performance and are suitable for all sizes and types of machine tools.

## Enhanced performance

NC4+ Blue fixed systems have an enhanced measurement repeatability of  $\pm 0.5 \mu\text{m } 2\sigma$  on smaller separations and  $\pm 0.75 \mu\text{m } 2\sigma$  on larger ones.

Renishaw's fixed systems are available in several sizes and beam heights, with the greater beam height providing better access and mounting flexibility. The small footprint of NC4+ Blue and the ultra-compact design of the transmitter and receiver heads ensures that minimal space is taken up by the system in the machining volume, whilst maximising the tool measurement area.

The fixed system range offers users a proven solution for the majority of tool setting requirements for milling operations.



### Efficient removal of debris and coolant

An integrated air blast enables swift and efficient removal of machining debris and coolant from the tool prior to measurement, ensuring accurate results.

### Ease of installation

A secure connector and push-fit pneumatic fittings facilitate quick and simple retrofit of NC4 hardware, especially on complex machines.





## Separate NC4 systems

Separate systems offer a flexible and configurable alternative to fixed versions, enabling installations in machines where space on the table is limited.

### Flexible, robust and efficient

Renishaw's separate systems can be installed in various orientations and separations, for a wide variety of applications – including broken tool detection and accurate in-cycle tool measurement. This gives users the ability to set up the NC4 to suit their specific process control needs.

Separate systems can be set up at separations between 0.3 m and 5 m and can be supplied with brackets and fittings to suit each machine installation. These separate systems feature proven red laser technology, and the same optical protection systems as their fixed counterparts, ensuring accurate, robust performance, whatever the application.



# Intuitive tool setting software

Renishaw is committed to ensuring its products are easy-to-use. A comprehensive range of macro cycles and machine tool apps allows for quick and intuitive programming of measurement cycles.

## Non-contact tool setting macro software

Renishaw tool setting macro software allows you to set tool length and diameter offsets for single point and multiple point tools, perform in-cycle broken tool detection and manual or automatic (programmed) positioning.

To learn more about our extensive range of macro cycles, visit [www.renishaw.com/toolsettingsoftware](http://www.renishaw.com/toolsettingsoftware)

## GoProbe app

The GoProbe smartphone app creates a probing or tool setting routine with just a few quick taps. Simply select the required cycle and populate the data entry fields. The result is a single-line command that is entered into the CNC controller.



## Set and Inspect

Set and Inspect is a simple, intuitive, on-machine probing app for machine tool users who require an easy-to-use probing solution. Use the app to easily create probing and tool setting routines. These routines can be manually run, run as single cycles or executed as fully automated probing routines. Set and Inspect can upload probing routines to the CNC control automatically.



## Reporter

Reporter is an on-machine app designed to display measurement data and production trends in a quick and easy way. View live and historical measurement results from Set and Inspect-generated programs as well as non-contact tool setting macro routines. The app is installed onto a Windows®-based CNC control or a Windows tablet connected to the control via Ethernet.



For more information including machine tool controller compatibility, refer to the *Probe software for machine tools-programs and features* data sheet (Renishaw part no. H-2000-2298) or visit [www.renishaw.com/machinetoolapps](http://www.renishaw.com/machinetoolapps)







“ Much of the work we undertake is very small batch or one-off parts and components. We've been successful for two main reasons: Firstly, we do whatever we must to get the job done on time and to the right quality standards. Secondly, we use the latest Renishaw tool setting technology to minimise set-up times and to get the maximum productivity from our machines. This is vital if you want to make a profit on such low-volume work.

”  
JK Engineering (UK)



# Probing pays with Renishaw

Optimise your cutting process

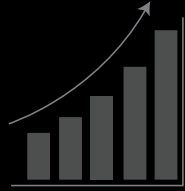

Ensure parts are machined "right first time".

Reduce scrap and rework



Set tools up to ten times faster than when using manual methods.

Save time and money



Produce more parts reliably and accurately.

## The Renishaw advantage



*At Renishaw, we enjoy an excellent reputation for offering strong support to our customers through a network of over 70 service and support offices worldwide.*

Technical assistance



We supply technical assistance to all our global customers.

Support and upgrades



We provide a variety of support agreements bespoke to your individual needs.

Training



We offer standard and bespoke training courses to meet your requirements.

Spares and accessories



Buy spares and accessories online or obtain quotes for Renishaw parts 24/7.



## Applying innovation since 1973

Renishaw is one of the world's leading engineering and scientific technology companies, with expertise in precision measurement and healthcare.

Our worldwide network of subsidiary companies and distributors provides dedicated global customer support, wherever you are.

### Our principal markets include:

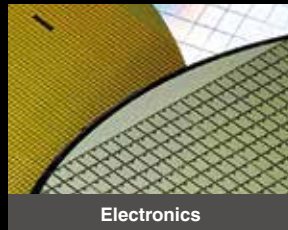

[www.renishaw.com/nc4](http://www.renishaw.com/nc4)



#renishaw

+44 (0) 1453 524524

 [uk@renishaw.com](mailto:uk@renishaw.com)

© 2021 Renishaw plc. All rights reserved. RENISHAW® and the probe symbol are registered trade marks of Renishaw plc. Renishaw product names, designations and the mark 'apply innovation' are trade marks of Renishaw plc or its subsidiaries. Other brand, product or company names are trade marks of their respective owners. Renishaw plc. Registered in England and Wales. Company no: 1106260.

Registered office: New Mills, Wotton-under-Edge, Glos, GL12 8JR, UK.

WHILE CONSIDERABLE EFFORT WAS MADE TO VERIFY THE ACCURACY OF THIS DOCUMENT AT PUBLICATION, ALL WARRANTIES, CONDITIONS, REPRESENTATIONS AND LIABILITY, HOWSOEVER ARISING, ARE EXCLUDED TO THE EXTENT PERMITTED BY LAW.

Part no.: H-2000-3630-02-A