

Intelligent program selection

Problem

In situations where a wide variety of components are manufactured, particularly where these components are difficult to distinguish visually, there is a significant possibility that an operator may select an incorrect machining program for the component. Depending on the level of variation between components, this may result in a scrapped part or damaged tooling.

Such scenarios often incorporate a procedure designed to minimise the risk of an incorrect program being loaded, however this procedure requires additional overhead in terms of documentation and training, is not fail-safe and requires time and effort to trace paperwork and data input errors. Where a component requires multiple machining operations, the risk per component is increased and the corresponding overhead to maintain the process may become significant.

Solution

AP200 Part identification describes a method of using a workpiece inspection probe to determine whether the component blank loaded in the machine tool is the correct one for the machining program.

Where a unique, identifiable feature exists on the component (or one can be added) a probe may be used to make a logical decision about which of the available cutting programs should be used.

A 'program selection' program uses the probe to identify which of a range of components is loaded into the machine, based on the following criteria:

- A known, identifiable feature - for example, the size of a feature within a casting may indicate which one of a family of components is loaded
- An additional feature which is added to the component during the set-up phase - for example, on a fixture containing a socket for a range of dowel pegs, the height or position of the peg may indicate the component loaded in the fixture

Benefits

- Eliminates the possibility of an incorrect machining program being run
- Greatly simplifies the process of managing correlation between processes and components
- Increases flexibility on the shop-floor when working with one offs and small batch components

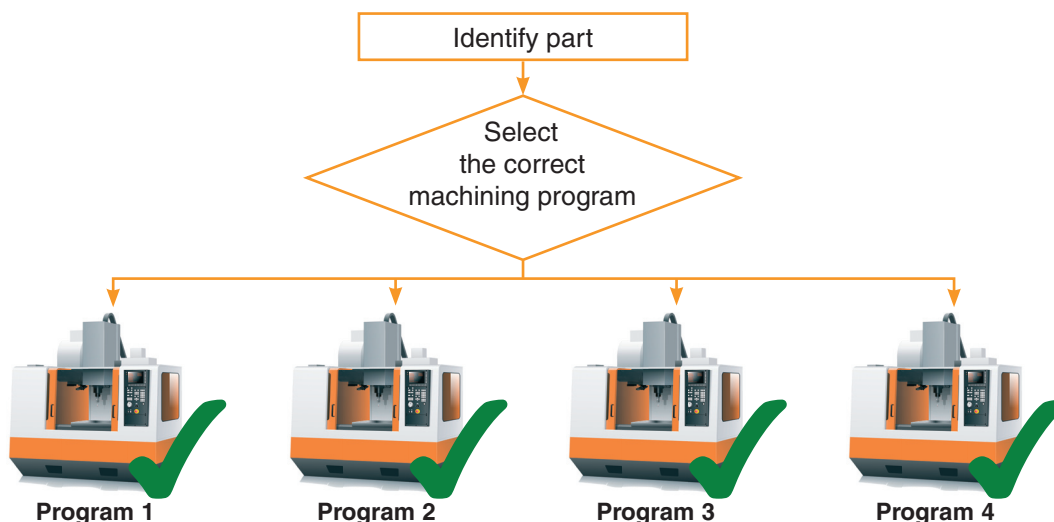

Example: identifying a component using a row of pegs

A probe is used to test for the presence of a peg on a component fixture. When a peg is present, i.e. Z is greater than zero, the corresponding machining program is run. If Z is not greater than zero, move to the next position and test for peg presence.

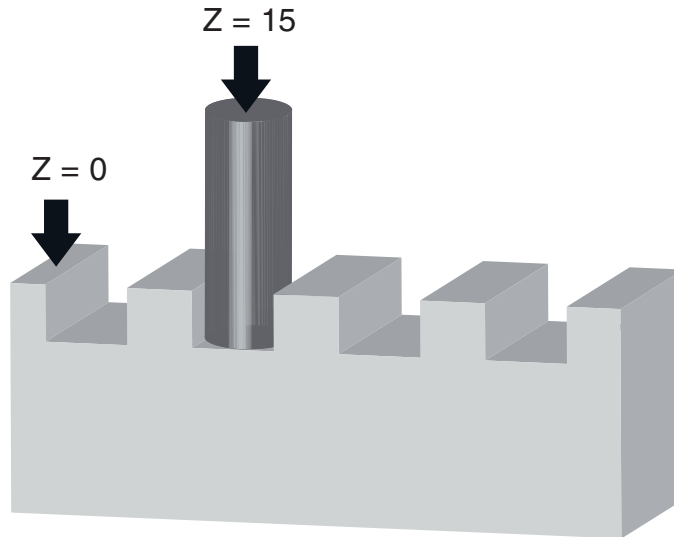

Sample Productivity+™ probe software program

```
Inspection Cycle: MeasureZPosition
  Measured Point: MeasureZZero

Inspection Cycle: Peg_1
  Measured Point: TestFirstLocation
  If: TestFirstLocation.Position.Z GT MeasureZZero.Position.Z
  Then:
    G-Code Block: Run_First_Program
    Goto: Finish_Program

Inspection Cycle: Peg_2
  Measured Point: TestSecondLocation
  If: TestSecondLocation.Position.Z GT MeasureZZero.Position.Z
  Then:
    G-Code Block: Run_Second_Program
    Goto: Finish_Program

Label: Finish_Program
G-Code Block: Finished
```

Establish Z = 0 position.

Probe first expected peg location. If Z is greater than zero (i.e. a peg is present), run first machining program.

Probe second expected peg location. If Z is greater than zero (i.e. a peg is present), run second machining program.

Sample Inspection Plus software program

T1 M6	Select the probe
G54 X0. Y0.	
G43 H1. Z100	
G65 P9810 X10. Y0.	Protected positioning move to first peg
G65 P9811 Z0.	Single surface measure of first peg
IF[#137GT0.]GOTO10	Jump to N10 and run first machining program
G65 P9810 X20. Y0.	Protected positioning move to second peg
G65 P9811 Z0.	Single surface measure of second peg
IF[#137GT0.]GOTO20	Jump to N20 and run second machining program
GOTO30	If the peg tests fail jump to N30 to alarm the machine
N10	
M98 P1001	First machining program
GOTO40	
N20	
M98 P1002	Second machining program
GOTO40	
N30	
#3000=99(NO PEG PRESENT)	Alarm - no pegs present
N40 (END)	

Renishaw plc
New Mills, Wotton-under-Edge,
Gloucestershire GL12 8JR
United Kingdom

T +44 (0) 1453 524524
F +44 (0) 1453 524901
E uk@renishaw.com
www.renishaw.com

RENISHAW 
apply innovation™

About Renishaw

Renishaw is an established world leader in engineering technologies, with a strong history of innovation in product development and manufacturing. Since its formation in 1973, the company has supplied leading-edge products that increase process productivity, improve product quality and deliver cost-effective automation solutions.

A worldwide network of subsidiary companies and distributors provides exceptional service and support for its customers.

Products include:

- **Dental CAD/CAM scanning and milling systems.**
- **Encoder systems for high accuracy linear, angle and rotary position feedback.**
- **Laser and ballbar systems for performance measurement and calibration of machines.**
- **Medical devices for neurosurgical applications.**
- **Probe systems and software for job set-up, tool setting and inspection on CNC machine tools.**
- **Raman spectroscopy systems for non-destructive material analysis.**
- **Sensor systems and software for measurement on CMMs (co-ordinate measuring machines).**
- **Styli for CMM and machine tool probe applications.**

Renishaw worldwide

Australia

T +61 3 9521 0922
E australia@renishaw.com

Austria

T +43 2236 379790
E austria@renishaw.com

Brazil

T +55 11 4195 2866
E brazil@renishaw.com

Canada

T +1 905 828 0104
E canada@renishaw.com

The People's Republic of China

T +86 21 6180 6416
E china@renishaw.com

Czech Republic

T +420 548 216 553
E czech@renishaw.com

France

T +33 1 64 61 84 84
E france@renishaw.com

Germany

T +49 7127 9810
E germany@renishaw.com

Hong Kong

T +852 2753 0638
E hongkong@renishaw.com

Hungary

T +36 23 502 183
E hungary@renishaw.com

India

T +91 80 6623 6000
E india@renishaw.com

Indonesia

T +62 21 2550 2467
E indonesia@renishaw.com

Israel

T +972 4 953 6595
E israel@renishaw.com

Italy

T +39 011 966 10 52
E italy@renishaw.com

Japan

T +81 3 5366 5316
E japan@renishaw.com

Malaysia

T +60 3 5631 4420
E malaysia@renishaw.com

The Netherlands

T +31 76 543 11 00
E benelux@renishaw.com

Poland

T +48 22 577 11 80
E poland@renishaw.com

Russia

T +7 495 231 16 77
E russia@renishaw.com

Singapore

T +65 6897 5466
E singapore@renishaw.com

Slovenia

T +386 1 527 2100
E mail@rls.si

South Korea

T +82 2 2108 2830
E southkorea@renishaw.com

Spain

T +34 93 663 34 20
E spain@renishaw.com

Sweden

T +46 8 584 90 880
E sweden@renishaw.com

Switzerland

T +41 55 415 50 60
E switzerland@renishaw.com

Taiwan

T +886 4 2473 3177
E taiwan@renishaw.com

Thailand

T +66 2 746 9811
E thailand@renishaw.com

Turkey

T +90 216 380 92 40
E turkiye@renishaw.com

UK (Head Office)

T +44 1453 524524
E uk@renishaw.com

USA

T +1 847 286 9953
E usa@renishaw.com

For all other countries

T +44 1453 524524
E international@renishaw.com

RENISHAW HAS MADE CONSIDERABLE EFFORTS TO ENSURE THE CONTENT OF THIS DOCUMENT IS CORRECT AT THE DATE OF PUBLICATION BUT MAKES NO WARRANTIES OR REPRESENTATIONS REGARDING THE CONTENT. RENISHAW EXCLUDES LIABILITY, HOWSOEVER ARISING, FOR ANY INACCURACIES IN THIS DOCUMENT.

©2010-2011 Renishaw plc. All rights reserved.

Renishaw reserves the right to change specifications without notice

RENISHAW® and the probe emblem used in the RENISHAW logo are registered trademarks of Renishaw plc in the UK and other countries. apply innovation, Productive Process Pyramid, Productive Process Patterns, Productivity+, AxiSet, Rengage, Trigger Logic, ToolWise, Sprint, MicroHole, PassiveSeal, SwarfStop, Equator and the versatile gauge are trademarks of Renishaw plc.

All other brand names and product names used in this document are trade names, service marks, trademarks or registered trademarks of their respective owners.



H - 5650 - 4005 - 01

Issued 0712 Part no. H-5650-4005-01-D