

TS20 probe system



Compliance information for this product is available by scanning the QR code or visiting www.renishaw.com/mtpdoc



Contents

Before you begin	1-1
Warranty	1-1
CNC machines	1-1
Care of the probe	1-1
Patents	1-1
Intended use	1-1
Safety	1-2
Information to the machine supplier/ installer	1-2
Information to the equipment installer	1-2
Equipment operation	1-2
TS20 basics	2-1
Introduction	2-1
Probe - signal processing options	2-1
Probe signal processing	2-1
TS20 mounted on an automatic arm with MI 8-4, HSI, or HSI-C interface	2-2
Probe - cable options	2-2
System installation	3-1
Specification	3-2
TS20 probe with straight stylus	3-2
TS20 probe with cranked stylus for applications where the straight stylus is not suitable	3-3
Overtravel	3-4
TS20 probe with signal conditioning module	3-4
Stylus fitting instructions	3-5
Stylus alignment in X and Z axes	3-6
Single conditioning module	3-6
TS20 probe with signal conditioning module	3-7
Electrical specification	3-7
TS20 with signal conditioning module (SCM)	3-7
Electrical characteristics at 20° C (68° F)	3-8
Typical performance with 4K7 load resistor and 24 V supply	3-8
Parts list	4-1

This page is intentionally left blank.

Before you begin

Warranty

Unless you and Renishaw have agreed and signed a separate written agreement, the equipment and/or software are sold subject to the Renishaw Standard Terms and Conditions supplied with such equipment and/or software, or available on request from your local Renishaw office.

Renishaw warrants its equipment and software for a limited period (as set out in the Standard Terms and Conditions), provided that they are installed and used exactly as defined in associated Renishaw documentation. You should consult these Standard Terms and Conditions to find out the full details of your warranty.

Equipment and/or software purchased by you from a third-party supplier is subject to separate terms and conditions supplied with such equipment and/or software. You should contact your third-party supplier for details.

CNC machines

CNC machine tools must always be operated by fully trained personnel in accordance with the manufacturer's instructions.

Care of the probe

Keep system components clean and treat the probe as a precision tool.

Patents

Non applicable.

Intended use

TS20 is a hardwired 2-axis touch-trigger probe used for tool setting on CNC lathes.

Safety

In all applications involving the use of machine tools or CMMs, eye protection is recommended.

Information to the machine supplier/ installer

It is the machine supplier's responsibility to ensure that the user is made aware of any hazards involved in operation, including those mentioned in Renishaw product literature, and to ensure that adequate guards and safety interlocks are provided.

If the probe fails, the probe signal may falsely indicate a probe seated condition. Do not rely on probe signals to halt the movement of the machine.

Information to the equipment installer

All Renishaw equipment is designed to comply with the relevant UK, EU and FCC regulatory requirements. It is the responsibility of the equipment installer to ensure that the following guidelines are adhered to, in order for the product to function in accordance with these regulations:

- Any interface MUST be installed in a position away from any potential sources of electrical noise, i.e. power transformers, servo drives etc.;
- All 0 V/ground connections should be connected to the machine "star point" (the "star point" is a single point return for all equipment ground and screen cables). This is very important and failure to adhere to this can cause a potential difference between grounds;
- All screens must be connected as outlined in the user instructions;
- Cables must not be routed alongside high current sources, i.e. motor power supply cables etc., or be near high-speed data lines;
- Cable lengths should always be kept to a minimum.

Equipment operation

If this equipment is used in a manner not specified by the manufacturer, the protection provided by the equipment may be impaired.

TS20 basics

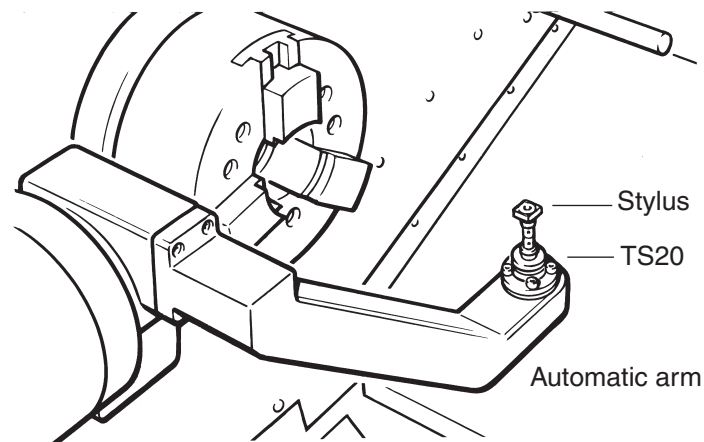

Introduction

The TS20 is a 2D touch-trigger probe which can be used for tool setting applications on CNC lathes.

During a tool setting routine, each turret mounted tool is driven against the square tip stylus. When contact is made, a trigger signal is generated and tool offsets are automatically recorded in the machine control registers.

There are three versions of the TS20 probe, for 24 mm, 32 mm or 40 mm tooling respectively.

Probe - signal processing options

Probe signal processing

A signal conditioning module (SCM) or interface unit (MI 8-4, HSI, or HSI-C) is required to process signals between the probe and CNC machine control.

TS20 mounted on a tool setting arm with signal conditioning module (SCM)

The SCM located within the tool setting arm, provides an OCT output.

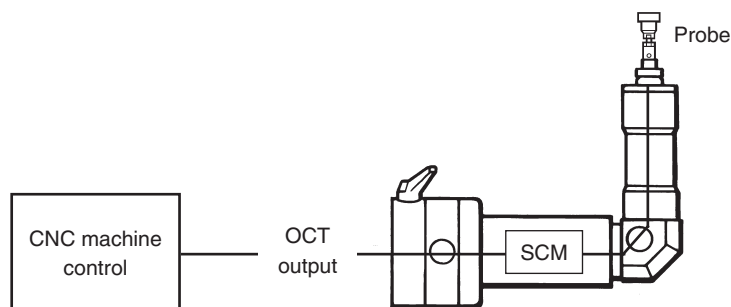

TS20 mounted on an automatic arm with MI 8-4, HSI, or HSI-C interface

MI 8 interface

An inhibit input enables an optical transmission type inspection probe and interface to be used on the same machine input as the TS20.

MI 8-4 interface

Where an inspection probe with optical transmission and an MI 12 interface, are used on the same machine as the TS20, the MI 8-4 interface is recommended.

The MI 8-4 interface accepts the probe output signal from the MI 12 interface. The user can then select between inspection or tool setting probe outputs by selecting an 'M' code.

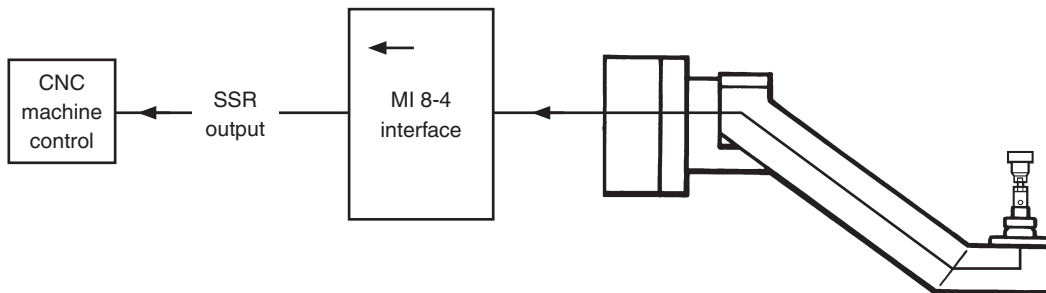

Probe - cable options

Cable is four core 7/0.2 polyurethane insulated and screened. Cable diameter 4.4 mm (0.17 in). Probe circuit - **red** and **blue** cores (yellow and green are not used).

Ensure the probe cable is routed away from other cables carrying high currents.

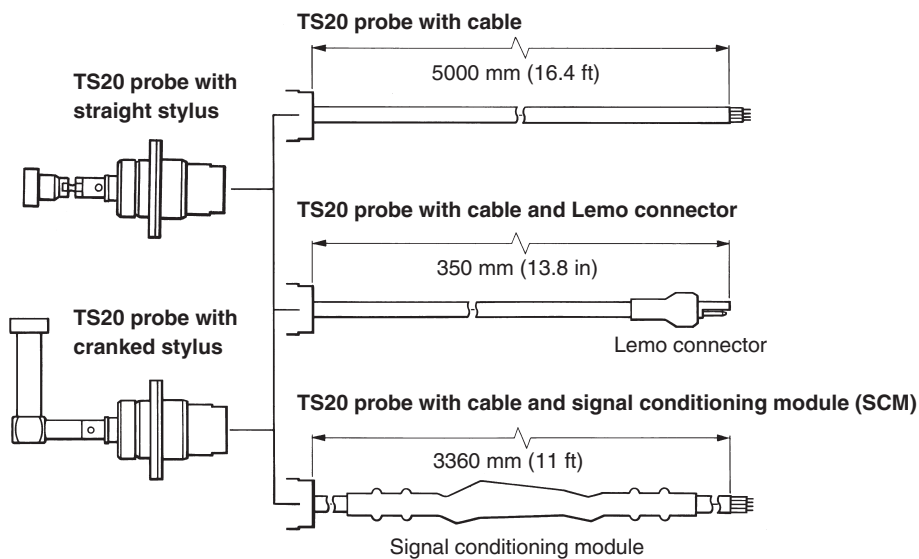

System installation

CAUTIONS:

The TS20 system must be installed by a competent person observing relevant safety precautions. Before commencing work, ensure the machine tool is in a safe condition with the power switched OFF. Switch off the power supply to the TS20 probe system components.

Cable from probe

Ensure the probe cable is routed away from other cables carrying high currents.

Probe false trigger

The TS20-SCM should be installed on machines with a stable power supply i.e. Interference free. If false triggers occur, investigate the power supply rails for interference.

Electrical interference

It is recommended that the interface unit is installed within the machine electronics control cabinet.

Normal electronic equipment installation rules apply, i.e. units should be mounted away from any potential sources of interference, such as three phase transformers and motor controllers.

Styli set-up

TS20 styli have an M3 thread and 10 × 10 mm tip. Straight styli incorporate a break stem to protect the probe in the event of a collision. A damaged stylus can be replaced - For more information, see **page 3-5**, “Stylus fitting instructions”.

TS20 probe with straight stylus

When a replacement stylus is fitted, the stylus squareness specification cannot be guaranteed, after the original stylus has been removed.

TS20 probe with cranked stylus

When a replacement styli is fitted, the stylus squareness and parallelism specification cannot be guaranteed, once the original stylus has been removed.

Software routines

Toolsetting software routines to suit various machine controllers are available from Renishaw (the current list is available on application).

Specification

TS20 probe with straight stylus

Sense directions	Normally $\pm X$ and $\pm Z$ axes of a lathe
Uni-directional repeatability. Maximum mean 2 sigma (2σ) value	2 μm (0.00008 in) Valid for test velocity of 480 mm/min (1.57 ft/min) at stylus tip
Temperature limits: Operating Storage	5° to 60° C (41° to 140° F) -13° to 60° C (9° to 140° F)

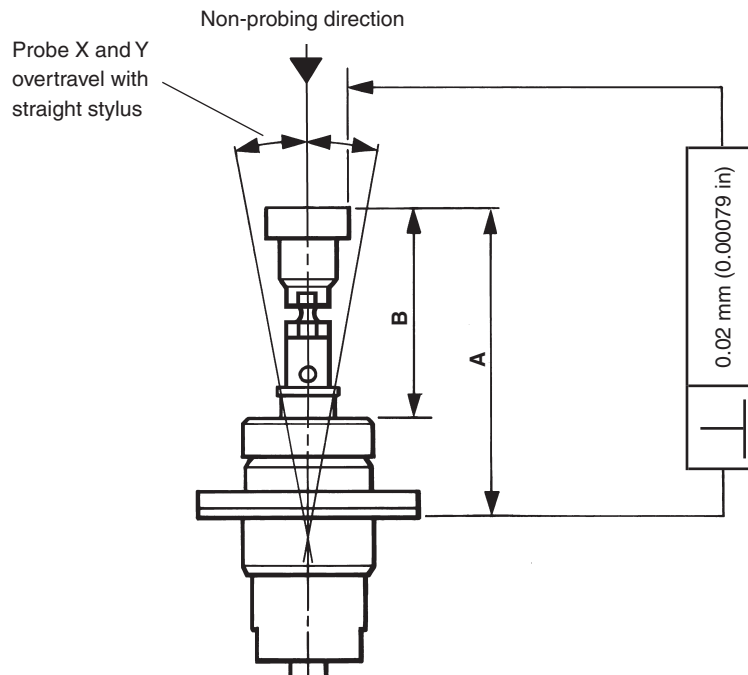

Tooling size	Dimension A also shown on page 3-7	Dimension B also shown on page 3-7	Stylus overtravel with straight styli	Uni-directional repeatability 2σ At a probing speed of 480 mm/min (1.57 ft/min)	Trigger force dependent on sense direction
25 mm (0.98 in)	41 mm (1.61 in)	28.25 mm (1.11 in)	± 6 mm (± 0.24 in)	2.0 μm (0.00008 in)	0.60 - 1.6 N 60 - 160 gf (2.12 - 5.64 ozf)
32 mm (1.26 in)	50 mm (1.96 in)	37.25 mm (1.46 in)	± 7.5 mm (± 0.30 in)	2.5 μm (0.0001 in)	0.47 - 1.26 N 47 - 126 gf (1.66 - 4.44 ozf)
40 mm (1.57 in)	58 mm (2.28 in)	45.25 mm (1.781 in)	± 9 mm (± 0.35 in)	3.0 μm (0.00012 in)	0.39 - 1.6 N 39 - 106 gf (1.38 - 3.74 ozf)

TS20 probe with cranked stylus for applications where the straight stylus is not suitable

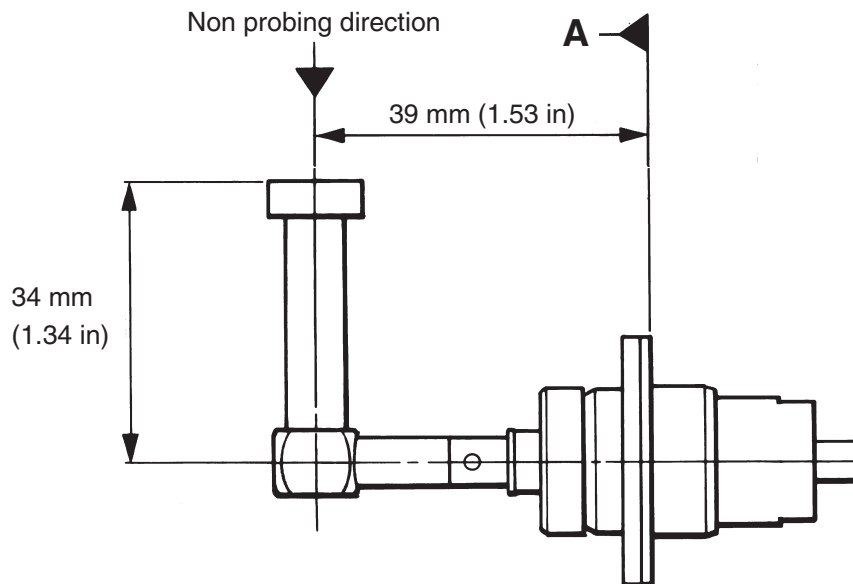
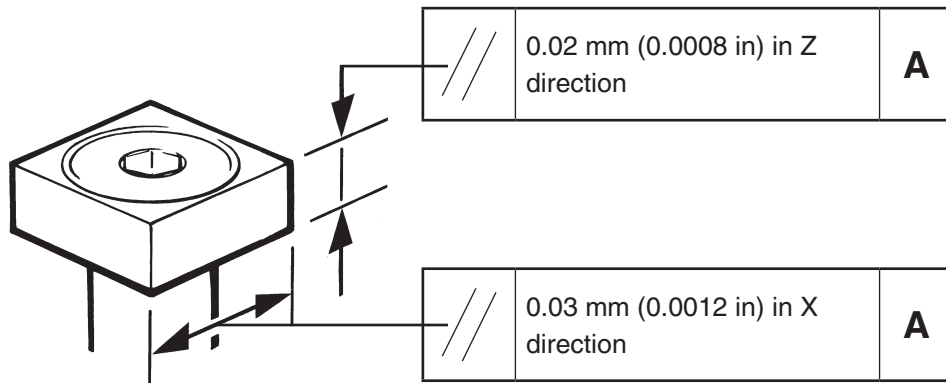

Uni-directional repeatability 2σ At a probing speed of 480 mm/min (1.57 ft/min)	Trigger force (dependent on sense direction)
2 μ m (0.00008 in)	0.6 - 1.6 N 60 - 160 gf (2.12 - 5.64 ozf)

NOTE: The characteristics of cranked styli do not allow them to have as good a repeatability performance as straight styli.

Overtravel

Do not exceed the quoted overtravel distance for each direction, otherwise the tool tip may slip off the stylus edge, and could cause damage to the probe.

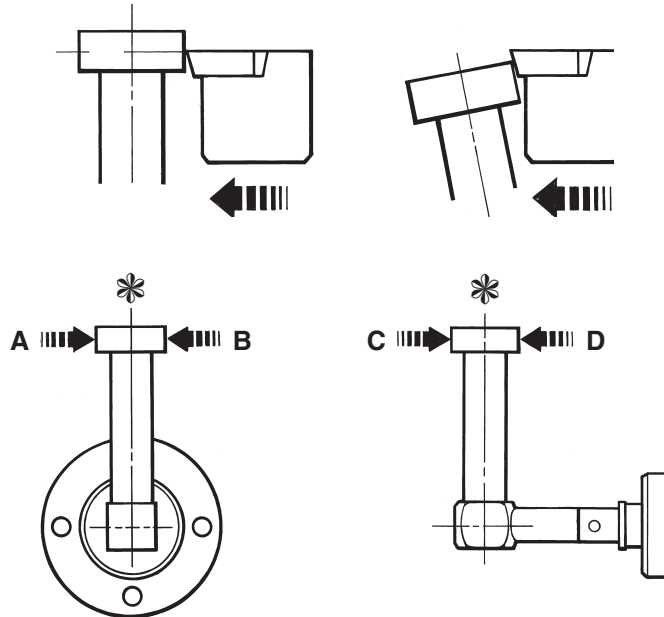

Direction	* Overtravel
A	3.0 mm (0.12 in)
B	3.0 mm (0.12 in)
C	1.2 mm (0.05 in)
D	2.3 mm (0.09 in)

TS20 probe with signal conditioning module

'O' ring supplied may be fitted in groove to seal probe mounting.
Recommended 'O' ring dimensions $\text{Ø}1 \times 18,1 \text{ ID}$ ($\text{Ø}0.039 \times 0.71 \text{ ID}$)

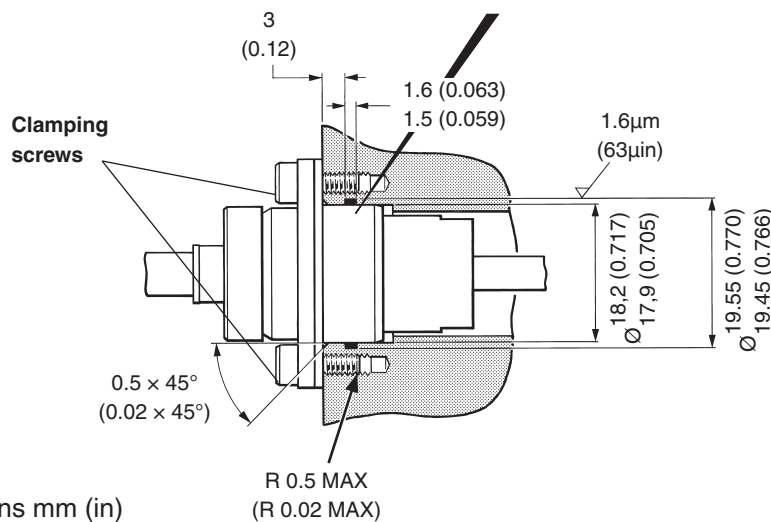

Stylus fitting instructions

The stylus break stem protects the probe in the event of a collision.

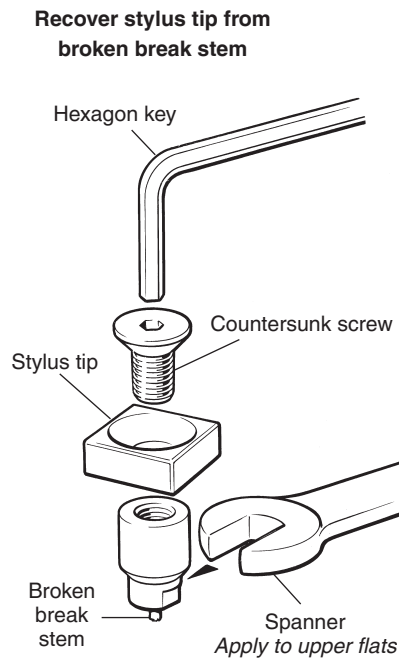

To recover stylus tip from a broken stem, use spanner on upper flats of stem.

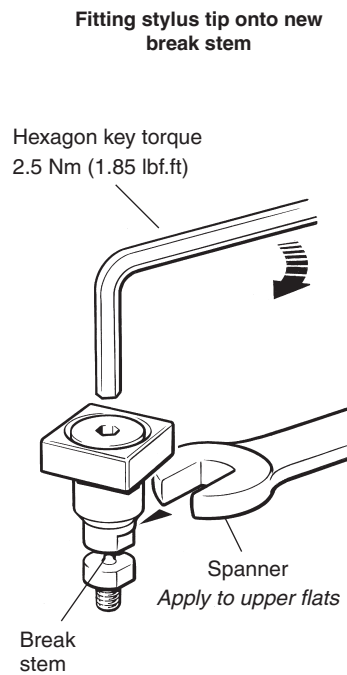

Before fitting stylus tip onto new stem, apply Loctite® 242 to thread of countersunk screw. Use spanner on upper flats of stem.

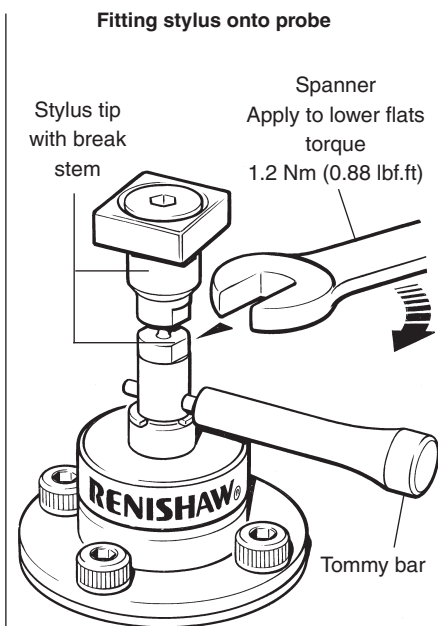

When fitting stylus to probe, support mounting with tommy bar and use spanner on lower flats of stem.

NOTE: Break stem - please quote the part number when ordering a replacement stem.

Application	Break stem part number	Application	Break stem part number	Application	Break stem part number
25 mm (tooling)	M-2008-0333	32 mm (tooling)	M-2008-0604	40 mm (tooling)	M-2008-0605

Stylus alignment in X and Z axes

Alignment of the stylus with the machine X and Z axes is obtained by slackening the four M3 × 8 mm clamping screws and rotating the probe body.

When alignment is achieved, tighten the clamping screws.

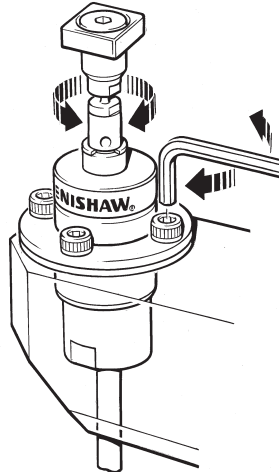

Signal conditioning module

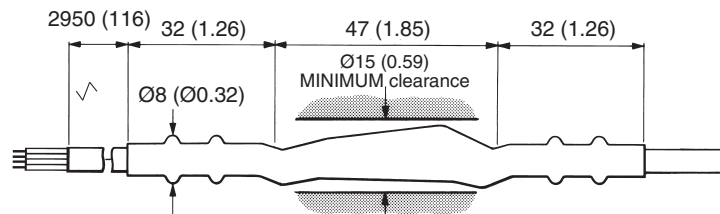

TS20 probe with signal conditioning module

Dimensions mm (in)

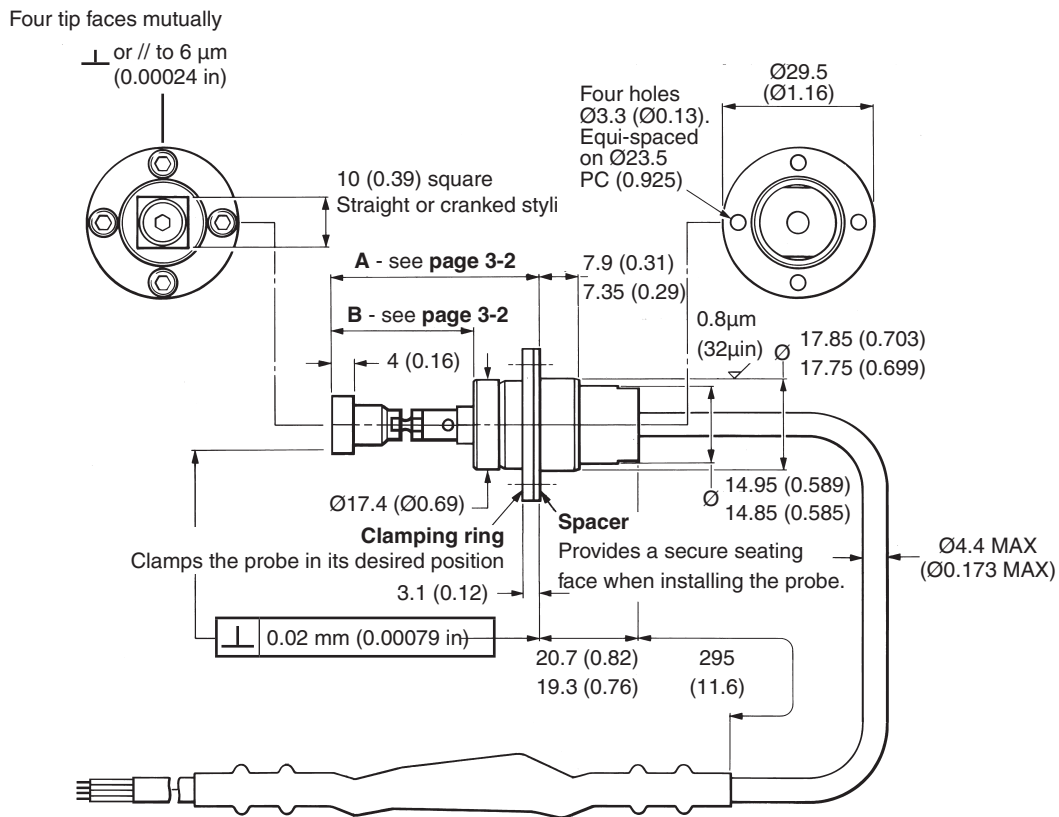

Electrical specification

TS20 with signal conditioning module (SCM)

The TS20 probe is designed to be used with a load resistor.

Minimum load resistor at 30 V	1K2 Ohms
Maximum supply voltage 30 V	Maximum current 25 mA - probe seated
Minimum supply voltage 9 V	Minimum current 2 mA - probe seated

Cable

Four core 7/0,2 polyurethane insulated and screened cable.

Probe circuit - **red** and **blue** cores, (*yellow and green are not used*).

The load resistor is connected in either positive or negative lead. For more information, see **page 3-8**, "Typical performance with 4K7 load resistor and 24 V supply".

It can be any value that does not cause the circuit to exceed the max/min current ratings.

The probe is protected against reverse voltage within the specified ratings.

Electrical characteristics at 20° C (68° F)

	Minimum	Typical	Maximum
Standby current (probe deflected)		320 μ A	500 μ A
Voltage drop across output leads (probe seated) Load current 25 mA		4.5 V	5.2 V
5 mA		3.5 V	3.9 V
2 mA		2.8 V	3.1 V
Output pulse length when probe deflects (trigger)	20.0 ms		

Typical performance with 4K7 load resistor and 24 V supply

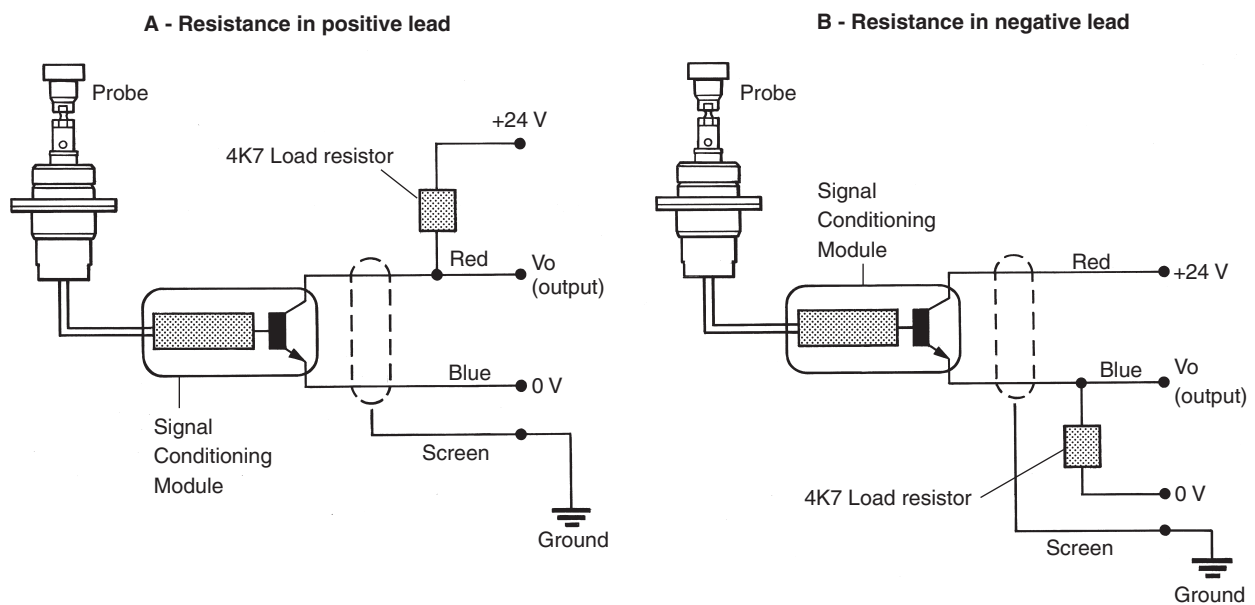

Probe	A - Resistance in positive lead			B - Resistance in negative lead		
	Minimum	Typical	Maximum	Minimum	Typical	Maximum
Output voltage (Vo) (probe seated)			3.9 V	20.1 V	20.5 V	
Output voltage (Vo) (probe deflected)	21.7 V	22.5 V			1.5 V	2.3 V

Parts list

Type	Part number	Description
TS20	A-2008-0002	TS20 probe, SCM, and 10 × 10 × 4 mm stylus
MI 8-4	A-2157-0001	MI 8-4 interface, support card and packaging.
HSI	A-5500-1000	HSI probe system interface, support card and packaging.
HSI-C	A-6527-1000	HSI-C probe system interface, support card and packaging.
STYLI for TS20. For more information, see “Stylus fitting instructions” on page 3-5.		
25 mm (tooling)	A-2008-0601	Straight stylus with square tip stylus 10 x 10 mm (0.39 x 0.39 in).
32 mm (tooling)	A-2008-0602	Straight stylus with square tip stylus 10 x 10 mm (0.39 x 0.39 in).
40 mm (tooling)	A-2008-0603	Straight stylus with square tip stylus 10 x 10 mm (0.39 x 0.39 in).
Cranked	A-2008-0249	Cranked stylus with square tip stylus 10 x 10 mm (0.39 x 0.39 in).
Associated system user guides		
MI 8-4	H-2000-5008	Installation and user guide: for the set-up of the MI 8-4.
HSI	H-5500-8554	Installation and user guide: for the set-up of the HSI.
HSI-C	H-6527-8501	Installation and user guide: for the set-up of the HSI-C.

www.renishaw.com/ts20



#renishaw

 **+44 (0) 01453 524524**  **UK@renishaw.com**

© 2002–2025 Renishaw plc. All rights reserved. This document may not be copied or reproduced in whole or in part, or transferred to any other media or language by any means, without the prior written permission of Renishaw.

RENISHAW® and the probe symbol are registered trade marks of Renishaw plc. Renishaw product names, designations and the mark 'apply innovation' are trade marks of Renishaw plc or its subsidiaries. Other brand, product or company names are trade marks of their respective owners.

WHILE CONSIDERABLE EFFORT WAS MADE TO VERIFY THE ACCURACY OF THIS DOCUMENT AT PUBLICATION, ALL WARRANTIES, CONDITIONS, REPRESENTATIONS AND LIABILITY, HOWSOEVER ARISING, ARE EXCLUDED TO THE EXTENT PERMITTED BY LAW. RENISHAW RESERVES THE RIGHT TO MAKE CHANGES TO THIS DOCUMENT AND TO THE EQUIPMENT, AND/OR SOFTWARE AND THE SPECIFICATION DESCRIBED HEREIN WITHOUT OBLIGATION TO PROVIDE NOTICE OF SUCH CHANGES.

Renishaw plc. Registered in England and Wales. Company no: 1106260. Registered office: New Mills, Wotton-under-Edge, Glos, GL12 8JR, UK.

Part no.: H-2000-5010-12-D

Issued: 03.2025