

## CMM controller cabinet user's guide

[www.renishaw.com](http://www.renishaw.com)

# CMM controller cabinet user's guide

Documentation part number: H-1000-5423-03-E



## CMM controller cabinet user's guide

www.renishaw.com

# CMM controller cabinet general information

© 2017 - 2025 Renishaw plc. All rights reserved.

 ORIGINAL LANGUAGE VERSION

This document may not be copied or reproduced in whole or in part, or transferred to any other media or language by any means, without the prior written permission of Renishaw.

## Disclaimer

WHILE CONSIDERABLE EFFORT WAS MADE TO VERIFY THE ACCURACY OF THIS DOCUMENT AT PUBLICATION, ALL WARRANTIES, CONDITIONS, REPRESENTATIONS AND LIABILITY, HOWSOEVER ARISING, ARE EXCLUDED TO THE EXTENT PERMITTED BY LAW.

RENISHAW RESERVES THE RIGHT TO MAKE CHANGES TO THIS DOCUMENT AND TO THE EQUIPMENT, AND/OR SOFTWARE AND THE SPECIFICATION DESCRIBED HEREIN WITHOUT OBLIGATION TO PROVIDE NOTICE OF SUCH CHANGES.

## Trade marks

RENISHAW®, the probe symbol and REVO® are registered trade marks of Renishaw plc.

Renishaw product names, designations and the mark 'apply innovation' are trade marks of Renishaw plc or its subsidiaries.

Other brand, product or company names are trade marks of their respective owners.

## WEEE



The use of this symbol on Renishaw products and / or accompanying documentation indicates that the product should not be mixed with general household waste upon disposal. It is the responsibility of the end user to dispose of this product at a designated collection point for waste electrical and electronic equipment (WEEE) to enable reuse or recycling. Correct disposal of this product will help to save valuable resources and prevent potential negative effects on the environment. For more information, please contact your local waste disposal service or Renishaw distributor.

## Warranty

Unless you and Renishaw have agreed and signed a separate written agreement, the equipment and/or software are sold subject to the Renishaw Standard Terms and Conditions supplied with such equipment and/or software, or available on request from your local Renishaw office.

Renishaw warrants its equipment and software for a limited period (as set out in the Standard Terms and Conditions), provided that they are installed and used exactly as defined in associated Renishaw documentation. You should consult these Standard Terms and Conditions to find out the full details of your warranty.

Equipment and/or software purchased by you from a third-party supplier is subject to separate terms and conditions supplied with such equipment and/or software. You should contact your third-party supplier for details.

## CMM controller cabinet user's guide

[www.renishaw.com](http://www.renishaw.com)

### Care of equipment

Renishaw probes and associated systems are precision tools used for obtaining precise measurements and must therefore be treated with care.

### Changes to Renishaw products

Renishaw reserves the right to improve, change or modify its hardware or software without incurring any obligations to make changes to Renishaw equipment previously sold.

### Company registration details

Renishaw plc. Registered in England and Wales. Company no: 1106260. Registered office: New Mills, Wotton-under-Edge, Gloucestershire, GL12 8JR, UK.

## CMM controller cabinet user's guide

[www.renishaw.com](http://www.renishaw.com)

# CMM controller cabinet product compliance

## EU declaration of conformity

Contact Renishaw plc or visit [www.renishaw.com/EUCMM](http://www.renishaw.com/EUCMM) for the full EU declaration.

---

## UK declaration of conformity

Contact Renishaw plc or visit [www.renishaw.com/UKCMM](http://www.renishaw.com/UKCMM) for the full UK declaration.

---

## EMC conformity

This equipment must be installed and used in accordance with this installation guide. This product is intended for industrial use only and should not be used in a residential area or connected to a low voltage power supply network which supplies buildings used for residential purposes.

---

## ICES-001 (Canada only)

This ISM device complies with Canadian ICES-001(A) / NMB-001(A).

Cet appareil ISM est conforme à la norme ICES-001(A) / NMB001(A) du Canada.

---

## REACH regulation

Information required by Article 33(1) of Regulation (EC) No. 1907/2006 ("REACH") relating to products containing substances of very high concern (SVHCs) is available at:

[www.renishaw.com/REACH](http://www.renishaw.com/REACH)

---

## CMM controller cabinet user's guide

[www.renishaw.com](http://www.renishaw.com)

### China RoHS

Contact Renishaw plc or visit [www.renishaw.com/ChinaRoHSCMM](http://www.renishaw.com/ChinaRoHSCMM) for the full China RoHS tabulation.



---

### Nationally recognised testing laboratory (NTRL)

This equipment has been independently certified by TÜV SÜD America Inc in accordance with OSHA (US) and SCC (Canada) requirements to the standards UL61010-1 Second Edition and CAN/CSA-C22-2 No. 61010-1 Second Edition.

## CMM controller cabinet user's guide

www.renishaw.com

# CMM controller cabinet safety

 Where this symbol is displayed on the product the user must refer to the installation and user guide for information and safety advice.

If the equipment is used in a manner not specified by the manufacturer then the safety of the equipment may be impaired.

 **WARNING:** To prevent unexpected machine movement, the user is advised to isolate the machine from the electricity supply, compressed air or other energy sources in accordance with the machine manufacturer's instructions before entering the danger zone or performing any maintenance operations.

 **WARNING:** The user's guide must be consulted in all cases where this symbol is used on the equipment, in order to find out the nature of the potential hazard and any actions which have to be taken.

## Emergency stop

 **NOTE:** Emergency stop is not considered to be a primary means of risk reduction for the hazards presented at a machine. All precautions advised by the machine manufacturer, the Renishaw product documentation and health and safety literature should be considered in determining the safety strategy for the use of this equipment.

The Renishaw system may provide the following safety categories, to standard EN ISO 13849, according to the type of servo amplifier fitted:-

**SPA2-2:** Category 2

The choice of the stop category of the emergency stop depends on the results of the user's risk assessment of the machine.

The emergency stop system, provided within the Renishaw servo amplifiers, has provision for the integration of external actuating devices.

The user should advise Renishaw of the requirements for such devices resulting from risk assessment.

Any emergency stop devices supplied by the user must comply with the requirements of UL1054 (EN60947) or other appropriate standards.

 **NOTE:** The overall safety of the system is the responsibility of the installer of the system.

## CMM controller cabinet user's guide

www.renishaw.com

# CMM controller cabinet environmental conditions

Indoor use	IP54 (IEC 60529)
Altitude	Up to 2000 m
Operating temperature	+5 °C to +40 °C
Storage temperature	-20 °C to +70 °C
Relative humidity	80% maximum (non-condensing) for temperatures up to +31 °C Linear decrease to 50% at +40 °C
Installation	Category II
Pollution degree	2

## CMM controller cabinet user's guide

[www.renishaw.com](http://www.renishaw.com)

# CMM controller cabinet introduction

Renishaw's CMM controller cabinet provides a solution for mounting Renishaw's range of CMM controllers, servo power amplifiers and interfaces, along with any compatible third party equipment. The cabinet uses standard 19 inch wide rack mounts.

Mains power distribution within the cabinet is controlled by a lockable isolation switch on the front of the cabinet.



## CMM controller cabinet user's guide

www.renishaw.com

# Product specification

## Environmental conditions

Indoor use	IP54 (IEC 60529)
Altitude	Up to 2000 m
Operating temperature	+5 °C to +40 °C
Storage temperature	-20 °C to +70 °C
Relative humidity	80% maximum (non-condensing) for temperatures up to +31 °C Linear decrease to 50% at +40 °C
Installation	Category II
Pollution degree	2

## Supply information

Supply voltage	100 V to 240 Vac $\pm$ 10%
Frequency range	50 Hz / 60 Hz
Power consumption	10 A maximum

## Weight

Unpackaged (cabinet empty)	65 kg
----------------------------	-------

# CMM controller cabinet user's guide

www.renishaw.com

## Dimensions

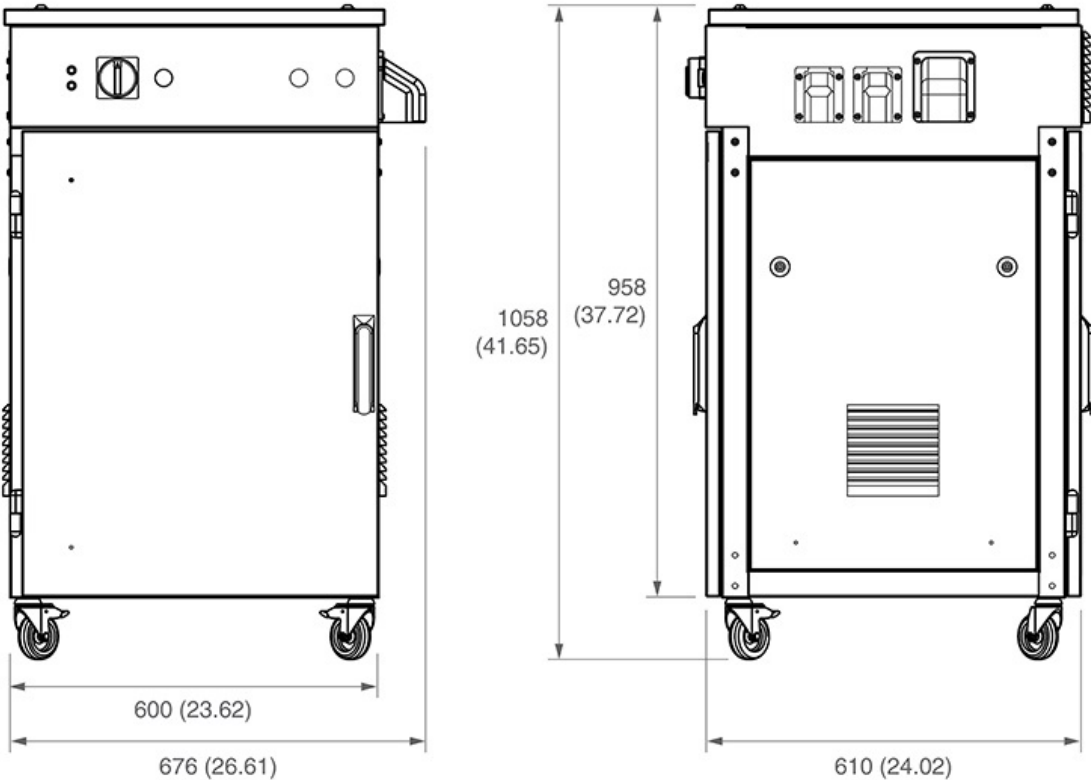

The cabinet has a 12-way IEC distribution panel which supplies power to control and ancillary equipment.

# CMM controller cabinet user's guide

www.renishaw.com

## Lifting

This denotes the lifting points on the cabinet:



**NOTE:** Lifting must only be carried out by the cabinet installer. Please contact the cabinet installer.

The CMM controller cabinet is lifted using the four eye bolts supplied.



Unscrew the four bolts securing the cabinet lid and remove.

Secure the four eye bolts in place in the holes labelled lifting points.

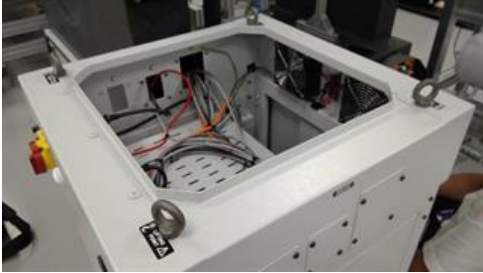

## CMM controller cabinet user's guide

www.renishaw.com

Use suitable slings as shown below.



**WARNING:** Specified cabinet weight is 65 kg with no control equipment installed. Please make provision for the weight of any equipment that is installed in the cabinet.

Following lifting, remove eye bolts and store within the controller cabinet. Keep eye bolts together using a cable tie or similar.

Replace the lid and bolt back in place ensuring the gasket washers are installed on each bolt.

## CMM controller cabinet user's guide

www.renishaw.com

# CMM controller cabinet description

## Isolation and control

The 12-way distribution panel has a lockable isolation switch that can be used to isolate the controller cabinet. Mains power isolation switch is located on the front of the cabinet. This switch removes power to internal IEC power outputs within the cabinet. The mains supply to the equipment is achieved via a IEC mains inlet connector.



The location of the mains power supply must be identified so it is clear and accessible to the operator how to remove power from the cabinet. This can be either at the mains plug on the wall or on any intermediate power supplementary power control equipment.



For maintenance to be carried out within the cabinet, the isolator switch should be turned off and power should also be removed from the mains plug or the supplementary power control equipment.



The cabinet must be located so users are able to easily access the power isolation switch.



The mains isolation switch on the wall or within supplementary power control equipment must be suitably labelled to identify its use.



The cabinet must be located to allow suitable ventilation to the fans.

For non-standard equipment configurations the equipment installed within the cabinet must provide its own fire enclosure.

# CMM controller cabinet user's guide

www.renishaw.com

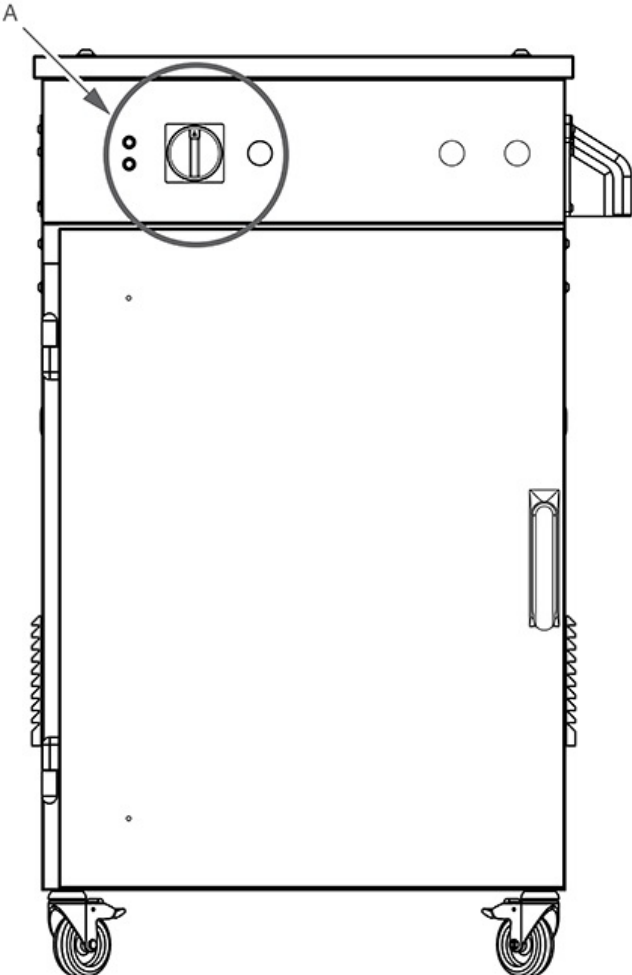

Detail A  
Scale 1:2

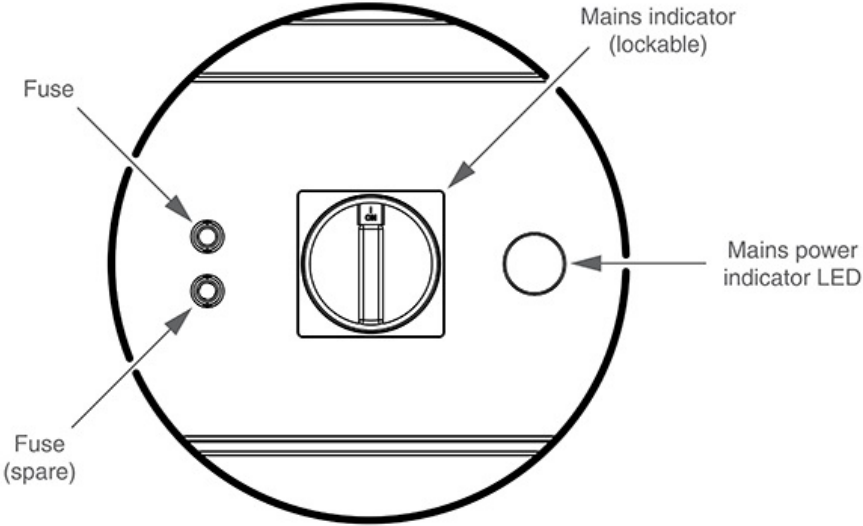

## CMM controller cabinet user's guide

[www.renishaw.com](http://www.renishaw.com)

### Fuse details

F10H250V

### Mains input connector

The cord used for connection to the mains must be rated to the minimum of supply specification detailed in '[Product specification](#)'.

IEC C13 10 amp power connector.

### Protective earthing



This equipment must be connected to a protective earth contact incorporating a protective earth conductor via a three core mains cable. This should not be negated by the use of an extension cable without a protective conductor.

# CMM controller cabinet user's guide

www.renishaw.com

## IEC power connections

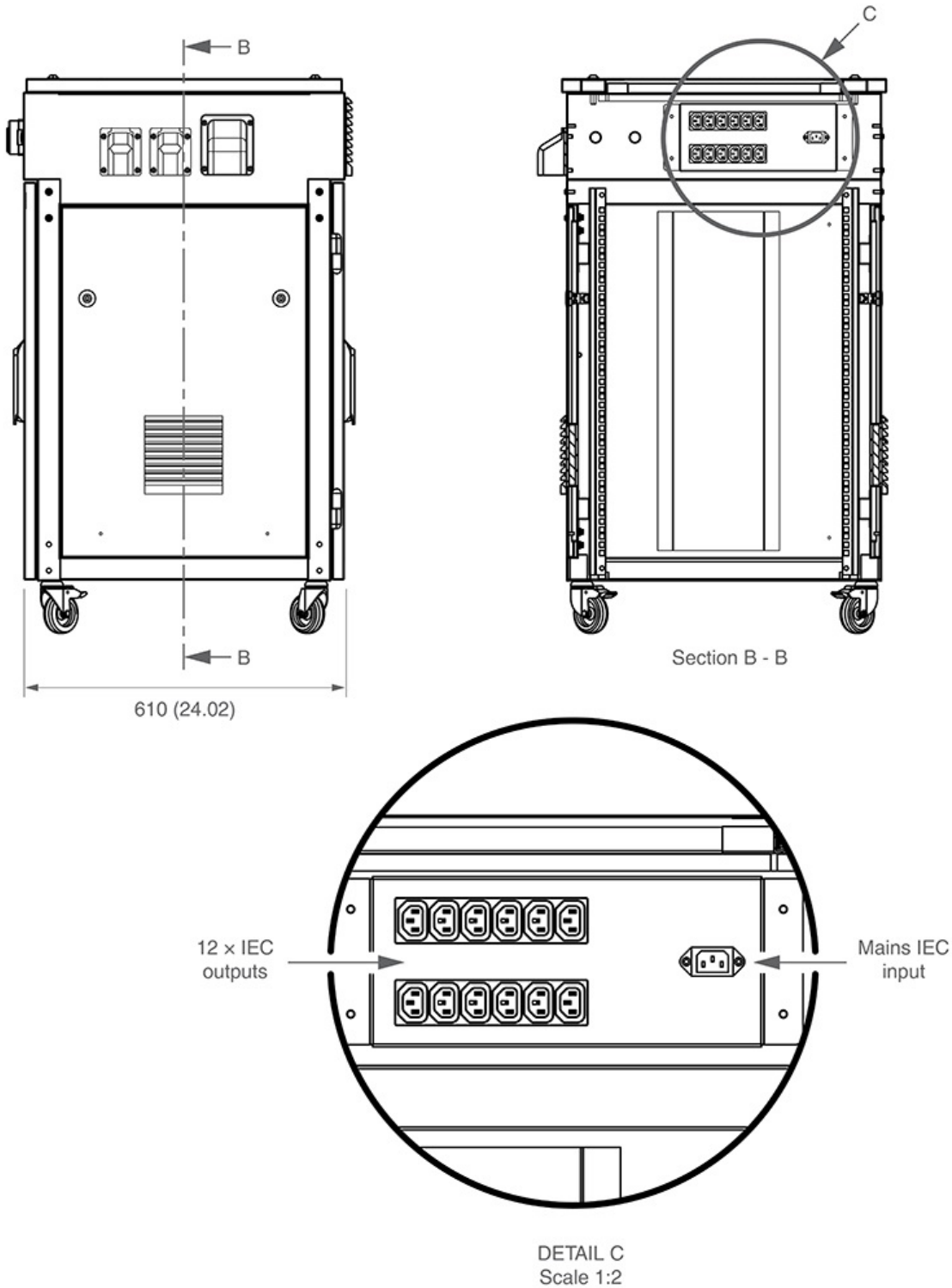



## CMM controller cabinet user's guide

www.renishaw.com

# Installation options

The cabinet must be restrained from toppling.

The preferred option is to use floor mounting fixings to secure the cabinet to the floor. The kick plates supplied in the cabinet kit should be secured to the floor. Pull force on floor fixing must be a minimum of 1 KN.

If cabinet cannot be fixed to the floor using kick plates then the suitable restraints should be used to remove the risk of the cabinet toppling.

## Attaching bulkhead to cabinet

The bulkhead can be attached using the 4 × fitting screws supplied.

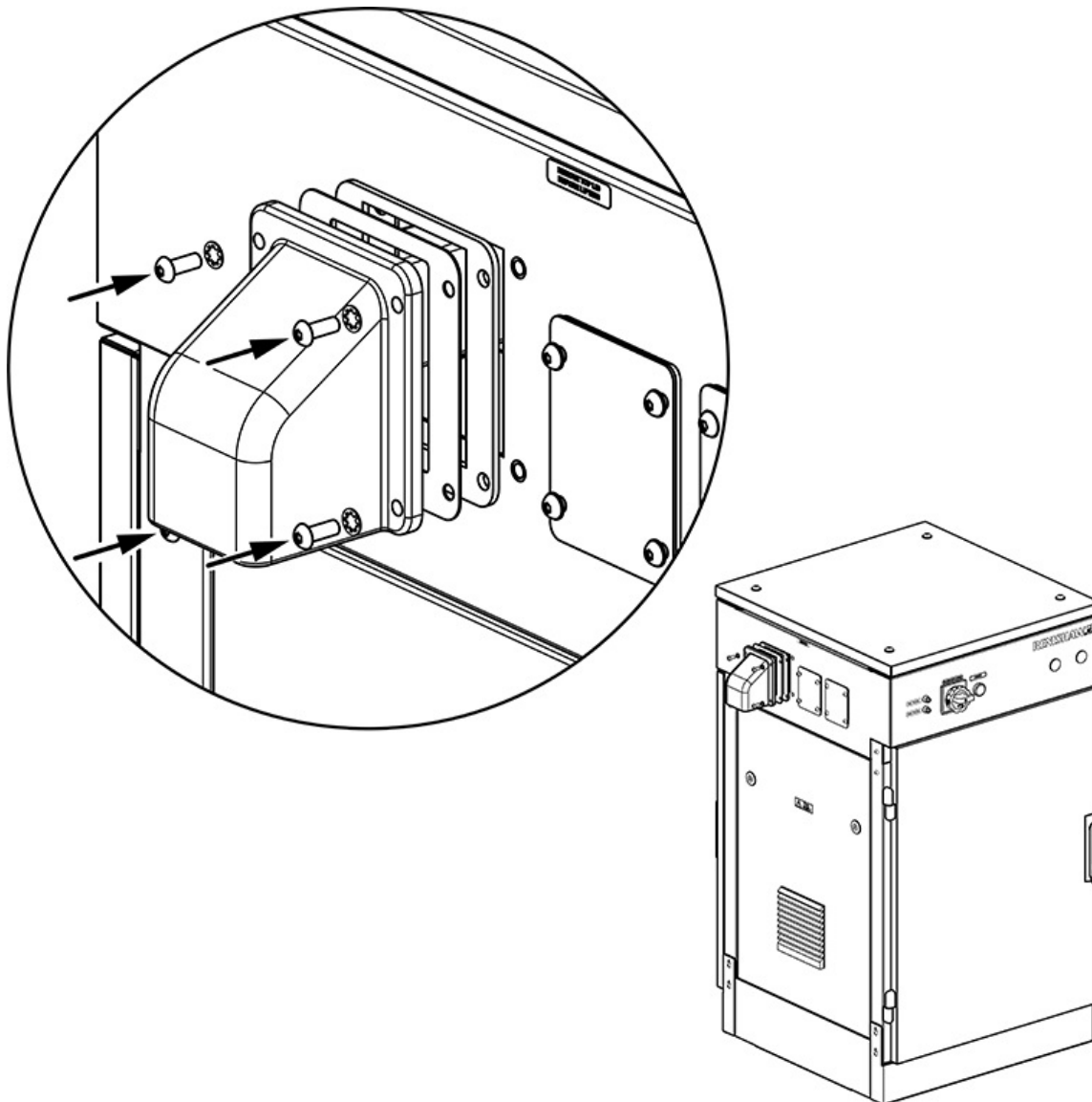

Tighten the screws using a 4 mm hex wrench to a maximum torque of 2 Nm.

## CMM controller cabinet user's guide

www.renishaw.com

### Kick plate installation overview

#### Positioning holes for ground fixing

The cabinet should be fixed to the ground as part of the installation. The diagram below shows the location of the required holes to allow the use of floor studs.

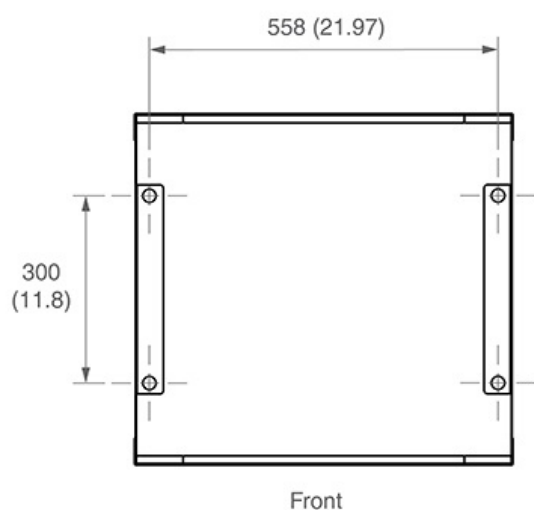

The type and size of studs used is dependent on the requirements of the installation site. These details should be discussed prior to installation.

1. Fix the left-hand side plate to the floor using anchors.
2. Roll the cabinet into position.

## CMM controller cabinet user's guide

www.renishaw.com

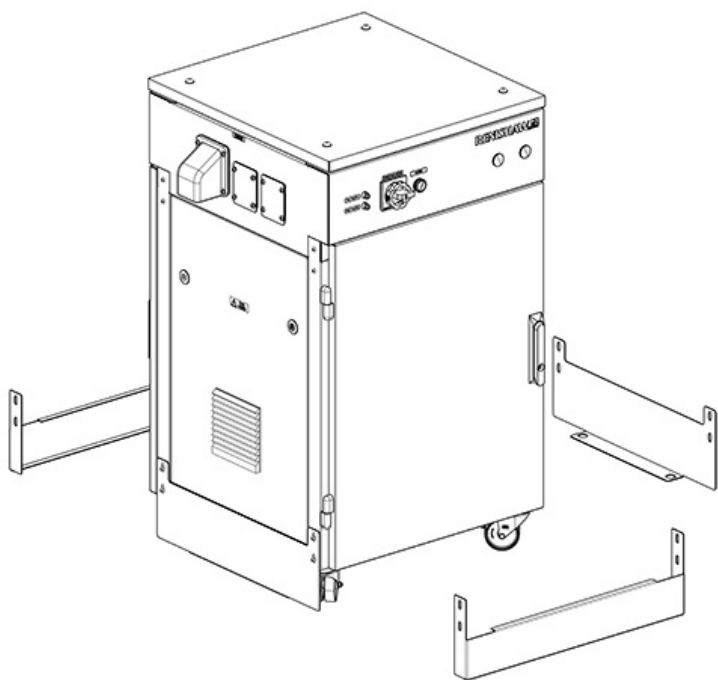

3. Fix the right-hand side plate to the floor using anchors.

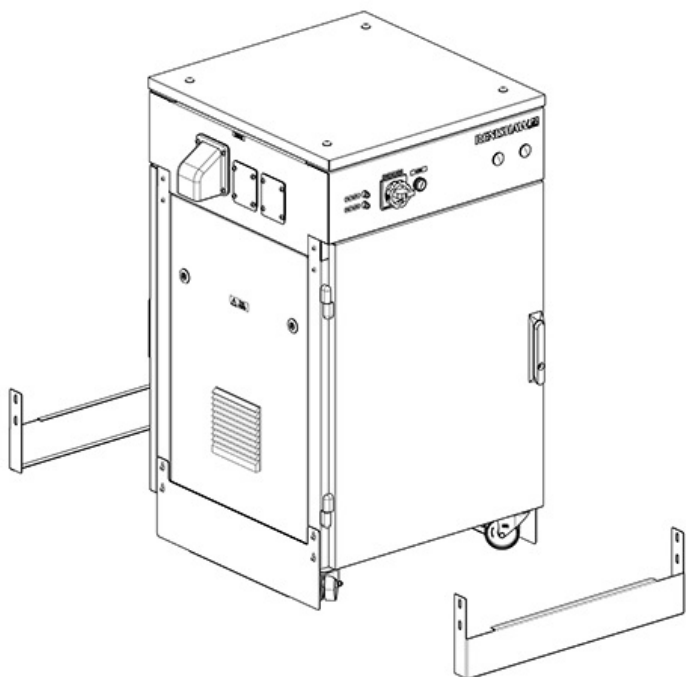

4. Fix the cabinet base to the side plates.

## CMM controller cabinet user's guide

www.renishaw.com

5. Once attached, fix the front and rear panels in place.

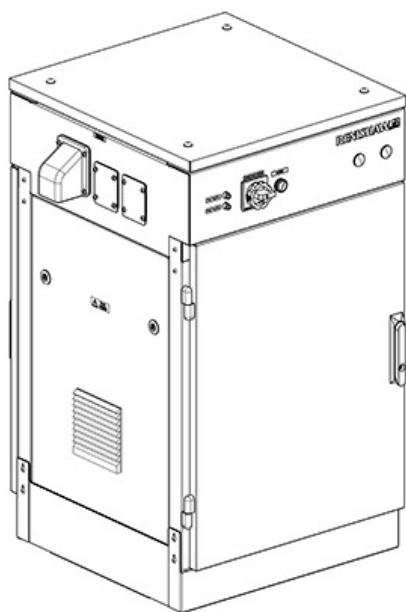

**NOTE:** If desired the cabinet can be re-positioned and re-installed by a single engineer with no lifting equipment. Please contact the installer to arrange reposition of the cabinet if required.

## CMM controller cabinet user's guide

www.renishaw.com

# CMM controller cabinet maintenance

## Authorised personnel service and maintenance

 **NOTE:** There is hazardous live 240 Vac present within the cabinet.

 **CAUTION:** Ensure that mains is fully isolated before any service or maintenance operations are carried out.

 **CAUTION:** Following any service and maintenance an inspection of the mains wiring and protective bonding should be carried followed by a PAT test.

## Periodic checks

It is advised to periodically check the cabinet and cable management system for damage or wear to key parts. Any visible damage or wear should be reported to the system maintenance engineer.

## User serviceable parts

The cabinet has two fans which are the only user serviceable components.

## Cooling fans

 **CAUTION:** Ensure the cabinet is switched OFF before changing the filter.

The two cabinet fans are used to push air out of the cabinet for cooling the equipment within. One is located on each lower side panel.

## CMM controller cabinet user's guide

www.renishaw.com

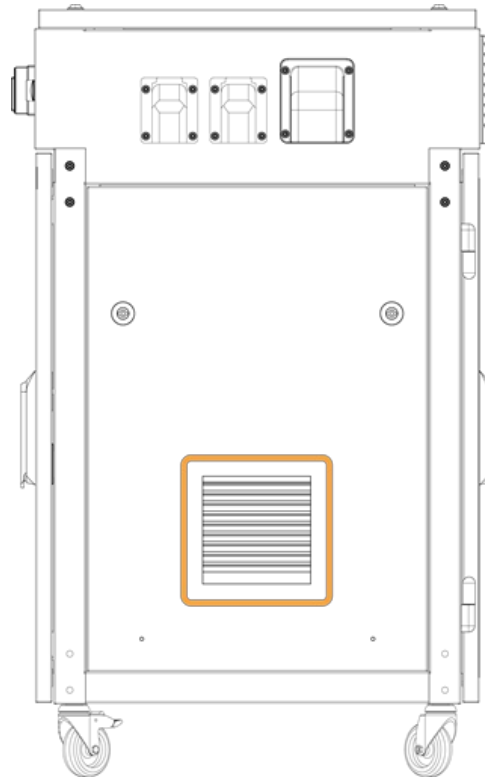

The fans have mesh filters. Renishaw recommends that these are changed at least every 12 months. If the kiosk is located in an environment with high levels of particulates in the air, the filters should be changed at more regular intervals.

Description	Part number
Mesh filter replacement kit (pack of five)	A-6509-0400

These filters should only be ordered from Renishaw.

## Cleaning

The CMM controller cabinet should be cleaned with a dry, lint-free cloth.

**Renishaw plc**  
New Mills, Wotton-under-Edge  
Gloucestershire, GL12 8JR  
United Kingdom

**T** +44 (0)1453 524524  
**F** +44 (0)1453 524901  
[www.renishaw.com/cmmsupport](http://www.renishaw.com/cmmsupport)



**For worldwide contact details,  
please visit our main website at  
[www.renishaw.com/contact](http://www.renishaw.com/contact)**