

Transforming tomorrow together

Capital Markets Day 2024

Will Lee
Chief Executive



RENISHAW 
apply innovation™

Agenda

10.00 –
10.45

Mission, ambition & strategy

Q&A

Will Lee,
Chief Executive



Allen Roberts
Group Finance Director



10.45 –
11.15

Markets & competitive position

Marc Saunders

Director of Group Strategic Development



11.15 –
12.20

Strategic priority seminars

Rotations #1 and #2

12.20 –
13.35

Lunch & exhibition

Buffet lunch with exhibition stands

13.35 –
14.40

Strategic priority seminars

Rotations #3 and #4



Growing in existing markets

Steve Oakes

Director of Position Measurement



Increasing technology value - IM

Derek Marshall

Director of Industrial Metrology



Increasing technology value - AM

Louise Callanan

Director of Additive Manufacturing



Extending into new markets

Blake Kendrick

Industrial Automation S&M Manager



14.40 –
15.05

Refreshments

Tea & coffee

15.05 –
15.35

Manufacturing strategy

Gareth Hankins

Group Manufacturing Director



15.35 –
16.05

Growth investment & driving returns

Marc Saunders



16.05 –
16.30

Summary of day & final Q&As

Will Lee



16.30

Event ends

Coach departs for station at **16.40**

Renishaw today

We make it possible to create the products, materials and therapies that will define our world in the decades to come and touch billions of lives

Manufacturing technologies

Analytical instruments & medical devices

Semicon production equipment

Machine shop

Robotics & automation

Lab & clinic

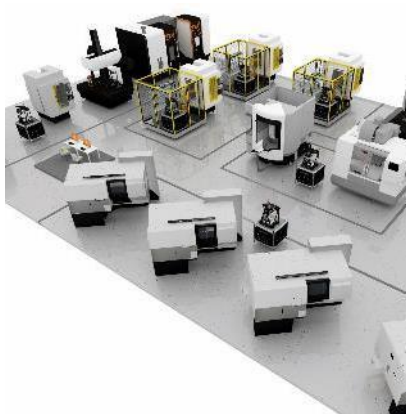

END-USE MARKETS

FY23 revenue

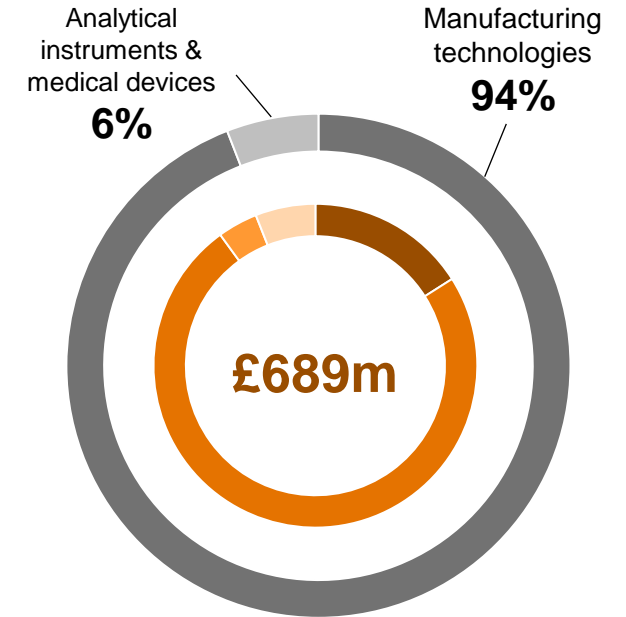

End-use markets where our products are used ¹

- Semicon production equipment (16%)
- Machine shop (74%)
- Robotics & automation (4%)
- Lab & clinic (6%)

Note

1. Unaudited management estimates – majority of sales are indirect, via machine builders and distributors

Global footprint

5,175 employees

67 locations

36 countries

- R&D mostly in UK
- Main manufacturing in UK, Ireland and India
- 94% revenues outside of UK

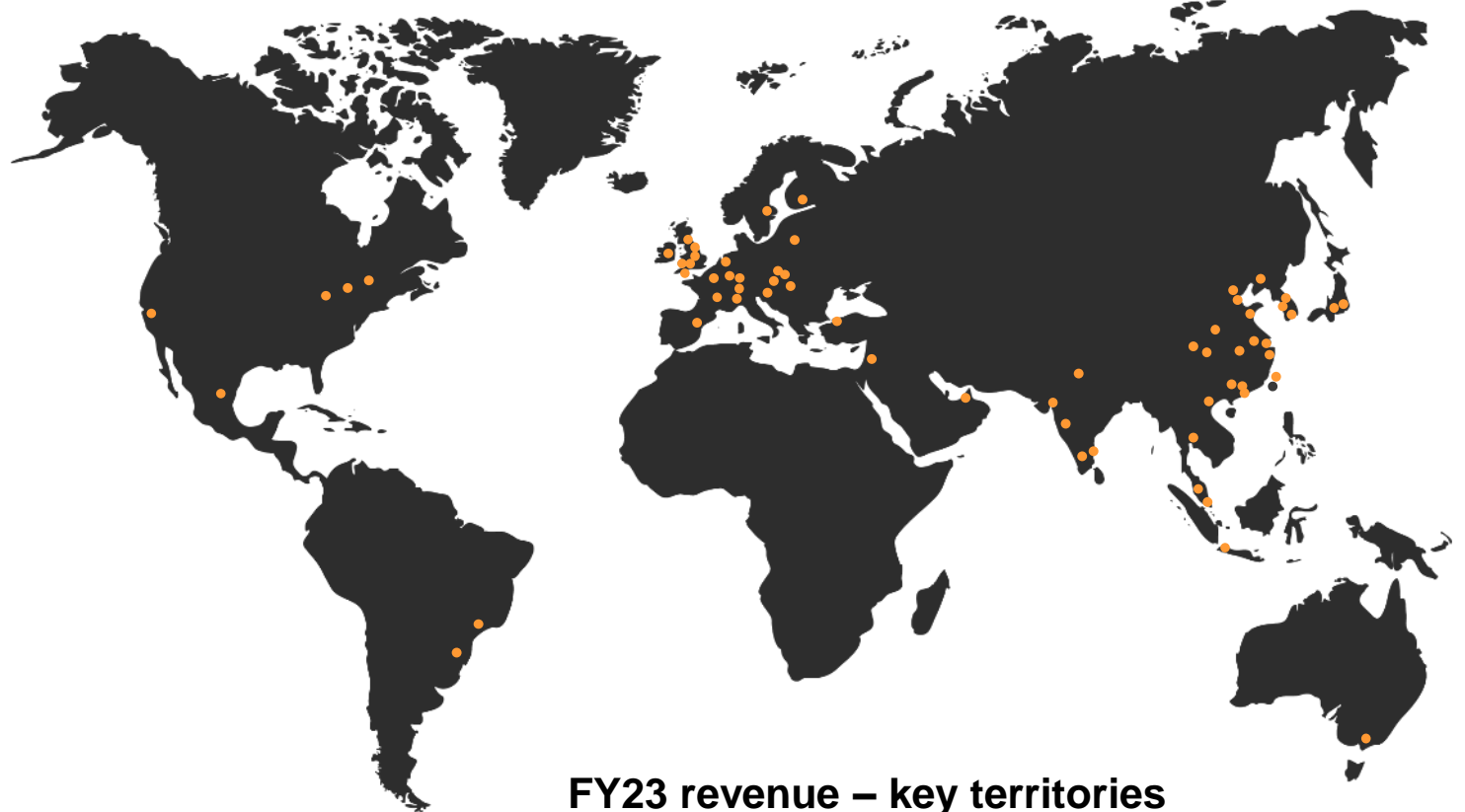

FY23 revenue by region

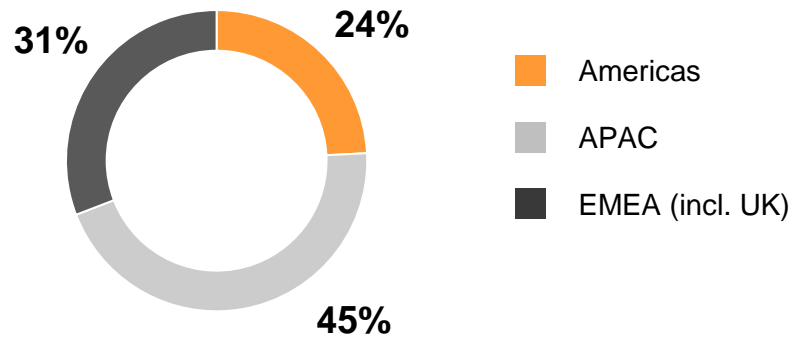

FY23 revenue – key territories

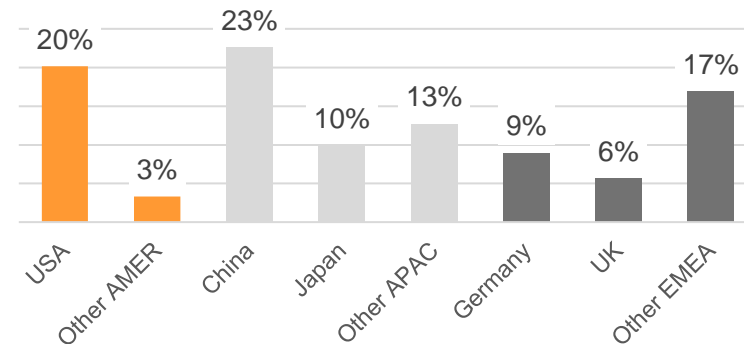

Our ambition

Manufacturing technology powerhouse

- ▶ Innovator in technologies for an automated, sustainable world
- ▶ Leading positions in an expanding range of high-growth markets
- ▶ Portfolio of sensor and software-enabled systems businesses
- ▶ High single digit through-cycle organic growth with >20% EBIT margin
- ▶ Responsible business that creates value for all our stakeholders

Long-term value creation model

Targeting high single digit through-cycle organic growth

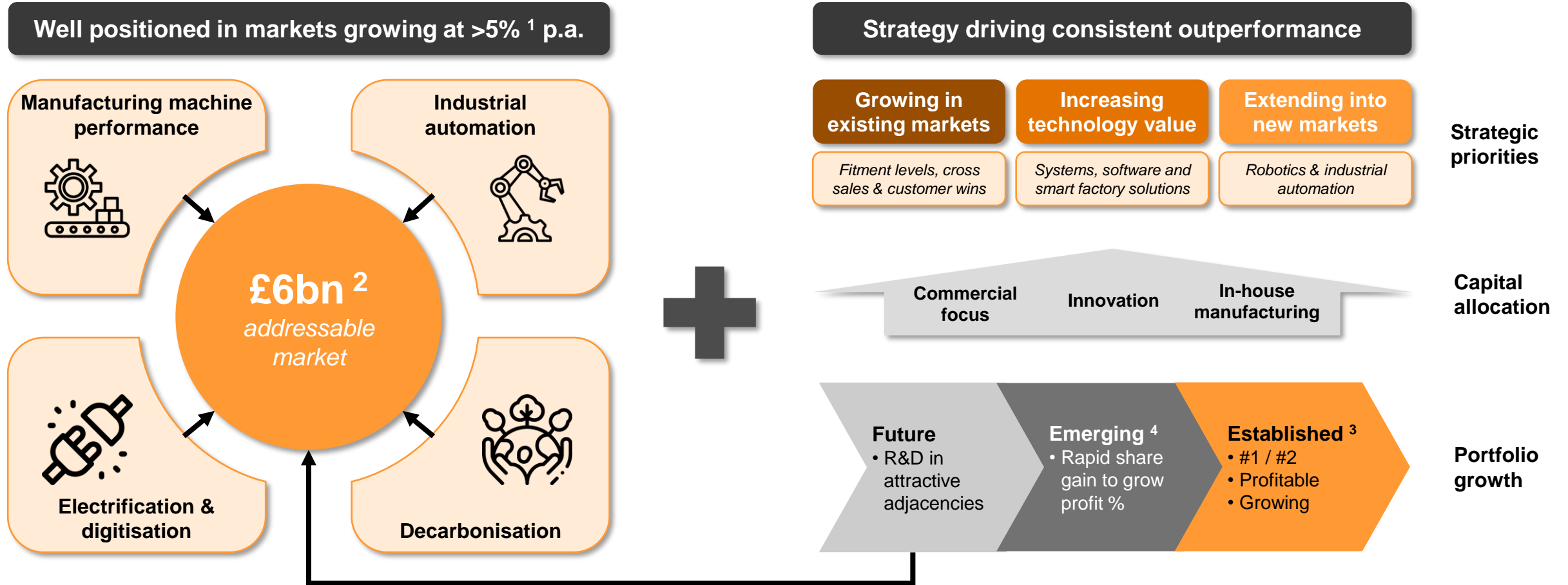

- Notes:**
1. Estimated weighted average through-cycle demand growth of Renishaw's addressable markets
 2. Unaudited management estimates from a combination of external market research and Company market knowledge
 3. Established portfolio products occupy a leading market position (#1 or #2 market share)
 4. Emerging portfolio products operate in more fragmented markets with significant opportunity to gain market share

Markets & competitive position

Value creation model

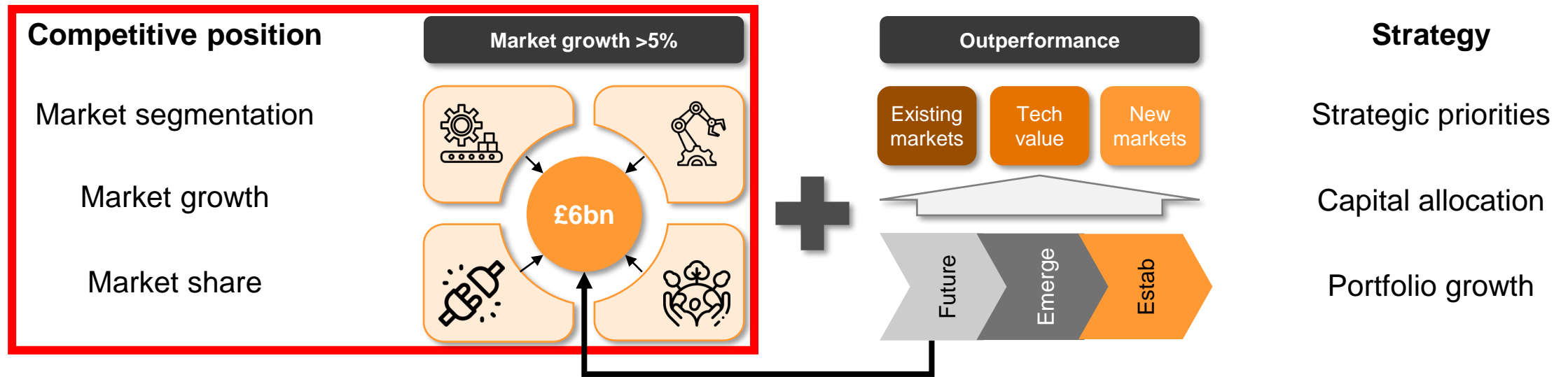

Attractive markets growing at >5% p.a.

Structural growth drivers underpinning sustained market growth

MANUFACTURING TECHNOLOGY

Manufacturing machine performance



Relentless drive to improve the **precision, speed and capability** of manufacturing equipment to make the advanced products of the future

Industrial processes are becoming more **automated** as manufacturers grapple with skilled labour shortages and aim to become more productive

Industrial automation

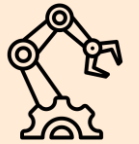

CHANGES IN WIDER SOCIETY



Electrification & digitisation

As the world becomes more **electrified and connected**, we are seeing sweeping changes in the transportation, electronics and semiconductor industries

The drive to **decarbonise** is forcing every manufacturer to rethink how we design, make and support our future products to minimise our environmental impact



Decarbonisation

Strong competitive position with opportunities for growth

Strong positions in multiple geographic and end-market niches

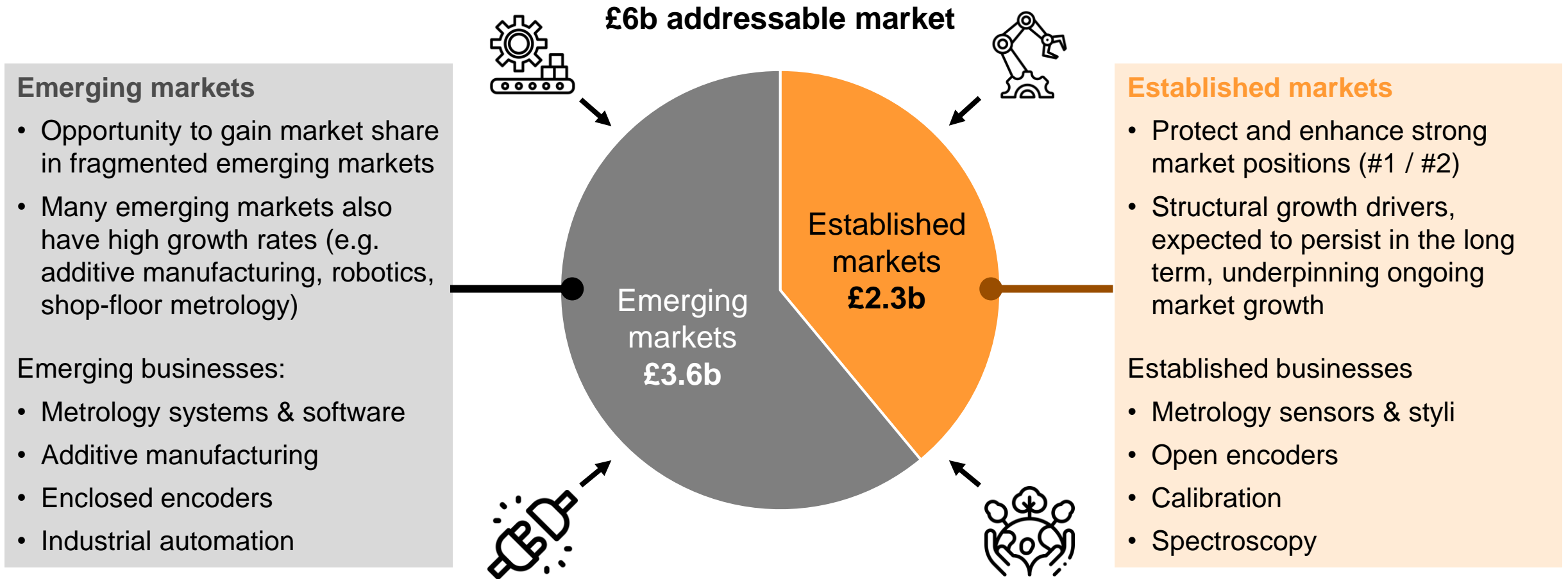

Out-performance strategy

Value creation model

Competitive position

Market segmentation

Market growth

Market share

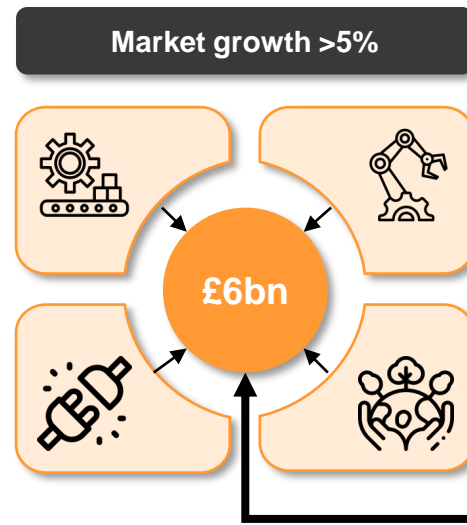

Outperformance

Existing markets

Tech value

New markets



Strategy

Strategic priorities

Capital allocation

Portfolio growth

Strategy to drive consistent outperformance

3 areas of strategic focus to combat competition & grow our market share

Strategy driving consistent outperformance

Growing in existing markets

Increasing technology value

Extending into new markets



Strategic priority

Increase revenue per machine tool

Win new machine builder customers

Build systems sales

Expand software business

Smart factory solutions

Diversify into close-adjacent markets

Businesses

Industrial Metrology
Position Measurement

Industrial Metrology
Position Measurement

Industrial Metrology
Additive Manufacturing

Industrial Metrology
Position Measurement
Additive Manufacturing

Industrial Metrology
Position Measurement
Additive Manufacturing

Industrial Metrology
Position Measurement

Notes
Current focus
Future focus

Investment in innovation and productivity

Capital allocation for through-cycle organic growth



Engineering

- **Maintain:** current products
- **Upgrade:** substitutional new products to enhance competitive position
- **New:** non-substitutional new products to meet new customer needs

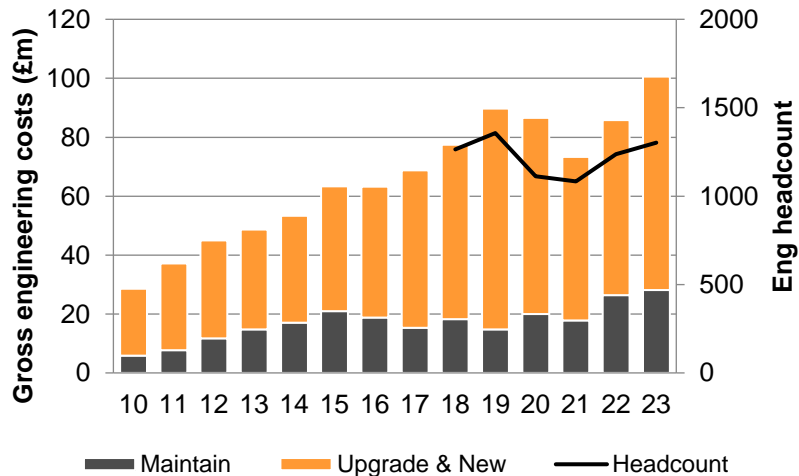

Sales & marketing

- Expand local teams to support existing & new customers
- Grow office network to support new customer locations
- Pay, travel & marketing expenses

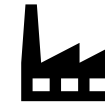
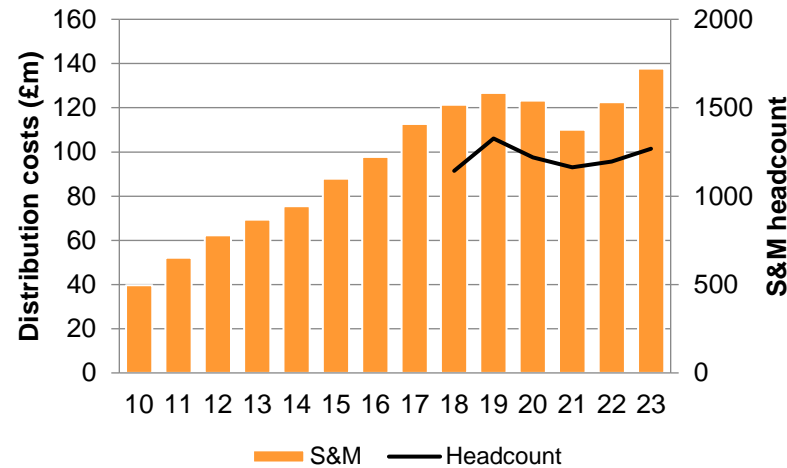

Capital expenditure

- Property, plant & equipment to grow our sales network, R&D facilities, IP assets and manufacturing capacity
- ROIC typically >15% ¹

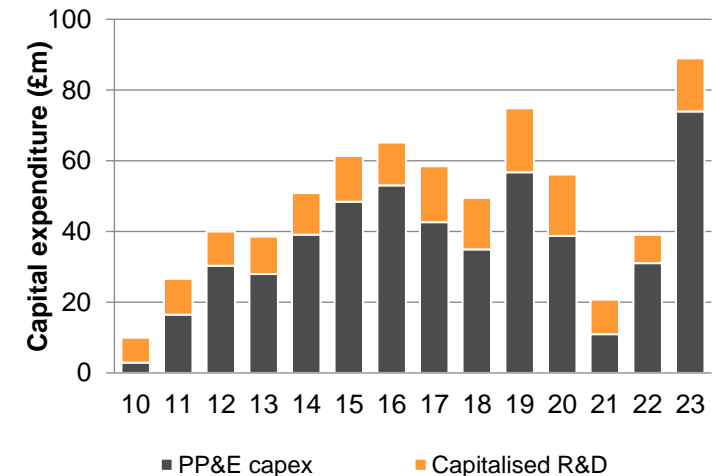

Notes

1. ROIC = return on invested capital = net operating profit after tax / average of (capital employed – cash & deposits)

Building our portfolio

An evolving portfolio of businesses providing profits, growth and exposure to new markets



R&D to develop a pipeline of innovative technologies & new products, enabling **diversification** into high-growth, close-adjacent markets



Rapid commercialisation of novel solutions to build substantial, profitable market positions in high-growth markets to move into Established



Protect and enhance our leading position in growing markets through superior product performance, quality and service

Portfolio growth

Financial track record

Sustained organic growth and strong operating margins

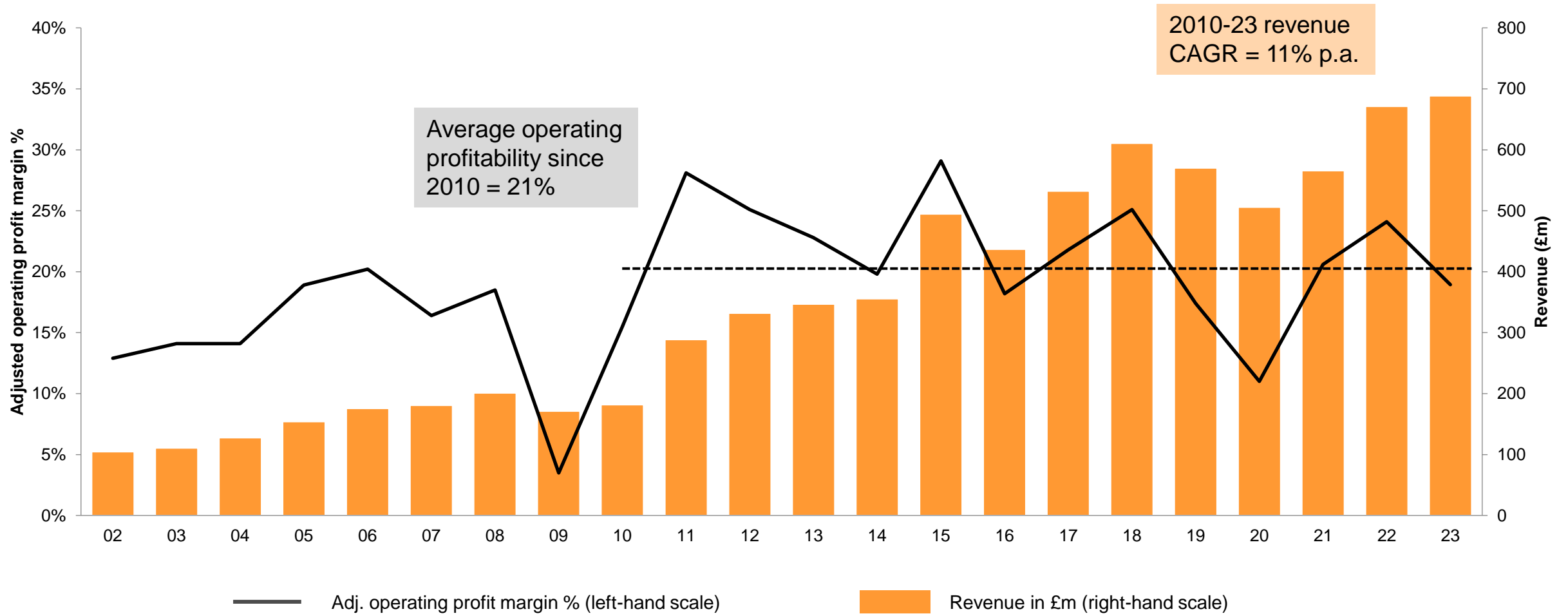

Delivering shareholder value

Long-term track record of dividend growth

Progressive dividend policy:

- Aims to increase dividend per share whilst maintaining a prudent level of dividend cover
- **£53m** in dividends paid in FY23

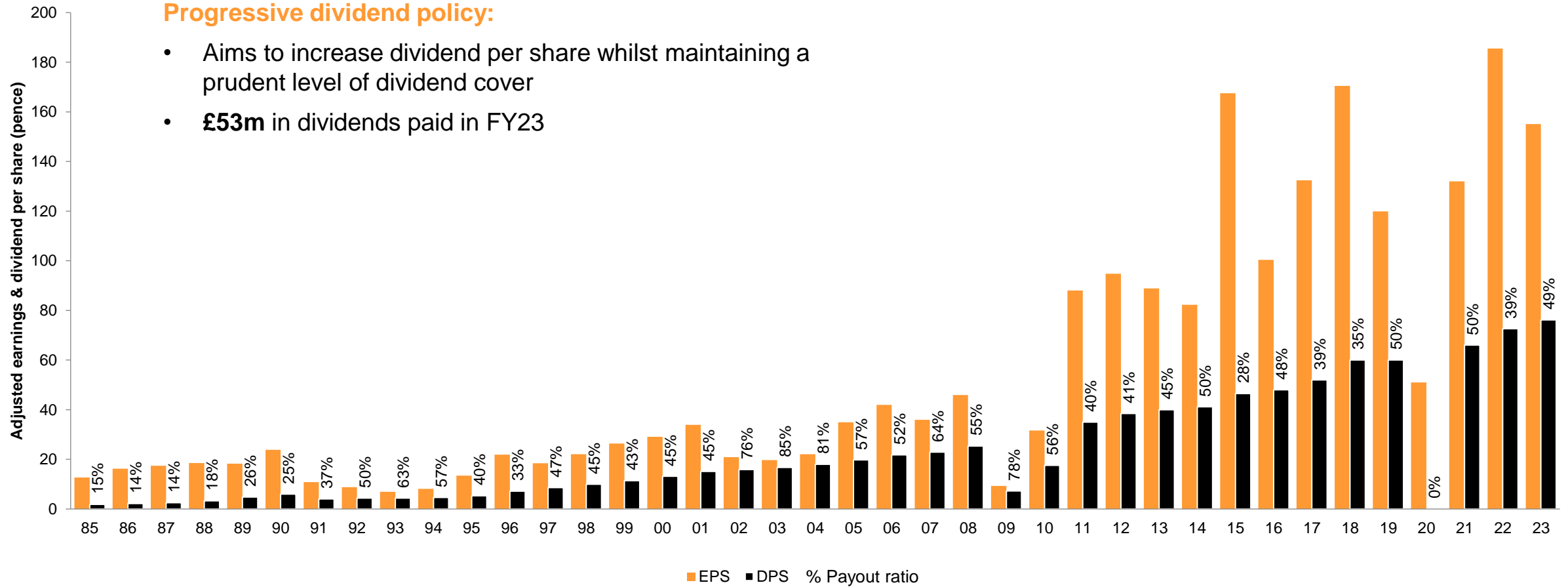

Transforming tomorrow together

We make it possible to create the products, materials and therapies that will define our world in the decades to come and touch billions of lives

Ambition

High single digit through-cycle organic growth with >20% EBIT margin

Value creation model

Competitive position

Market segmentation

Market growth

Market share

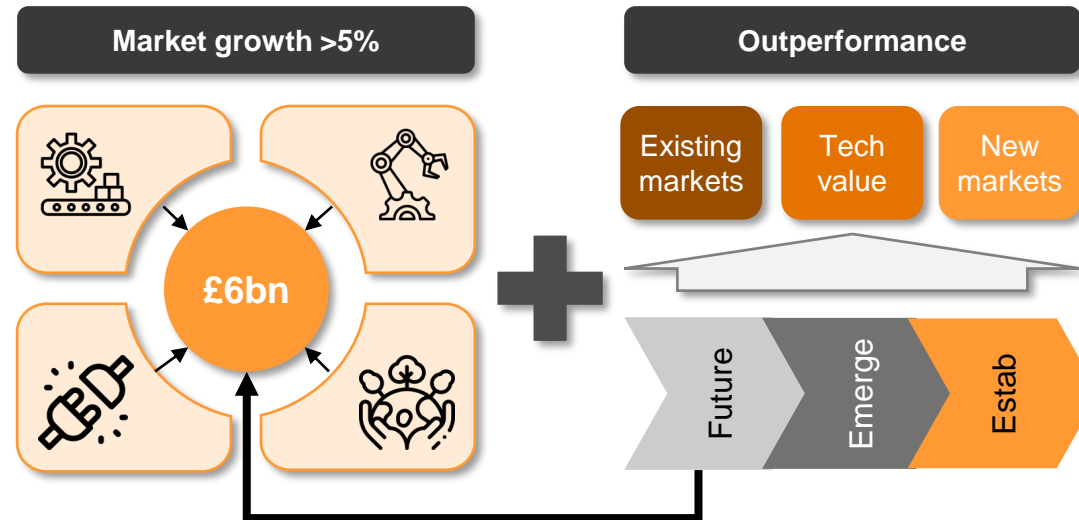

Strategy

Strategic priorities

Capital allocation

Portfolio growth

Results and strategy Q&A

Will Lee

Chief Executive



Allen Roberts

Group Finance Director



Markets & competitive position

Marc Saunders

**Director of Group Strategic
Development**



RENISHAW 
apply innovation™

Markets & competitive position

Value creation model

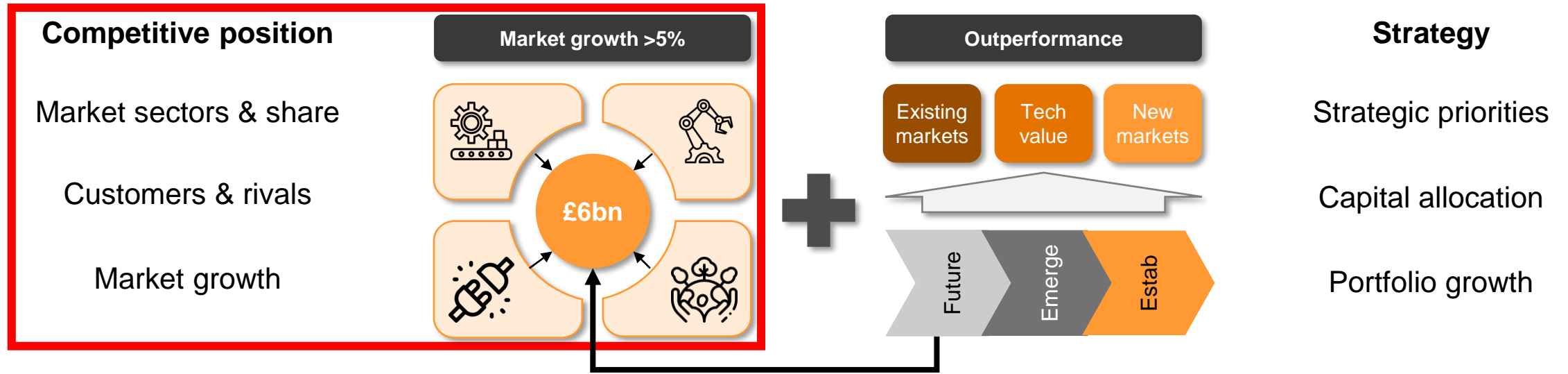

Market segmentation & business maturity



Our Product Groups & product lines



Renishaw plc

Manufacturing technologies

Analytical instruments & medical devices

PRODUCT GROUPS

Industrial Metrology



Measurement & control of precision component manufacturing processes

Established product lines:

- CMM sensors
- Machine tool probes
- Styli & fixturing

Emerging product lines:

- CMM & gauging systems
- Metrology software
- Smart manufacturing data platform

Position Measurement



Precision motion control of robotics, machinery and factory automation

Established product lines:

- Open optical encoders
- Laser encoders
- Magnetic encoders
- Calibration

Emerging product lines:

- Enclosed optical encoders
- Industrial automation

Additive Manufacturing



Production of intricate metal components from a digital model

Emerging product lines:

- Industrial metal 3D printers
- Build preparation & process monitoring software

Spectroscopy

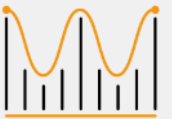

Materials analysis instruments

Established product line:

- Laboratory Raman spectroscopy

Emerging product line:

- Industrial process Raman

Neurological



Central nervous system surgical and drug delivery solutions

Industrial Metrology

Measurement & control of precision component manufacturing processes

Established
Emerging



Applications

Automated process set-up, in-process control and multi-sensor post-process monitoring of precision component manufacturing operations

Benefits

Enables tighter tolerances, eliminates reliance on skilled labour, minimises downtime and automates production

Renishaw's USPs

- Comprehensive range of CMM and machine tool sensors
- REVO® 5-axis multi-sensor measurement
- AGILITY® high-throughput CMMs
- EQUATOR™ flexible shop-floor gauge with Intelligent Process Control

Market-leading sensors

CMM sensors #1



Machine tool probes #1



Styli & fixturing #1



Innovative metrology systems & software

CMM & gauging systems **Rising**



Metrology software **Rising**



Renishaw Central **NEW**



Notes

#1 etc = Renishaw's assessment of its market position in each segment

Position Measurement

Precision motion control of machinery, robotics & factory automation

Established
Emerging



Applications

Precision motion control for semiconductor manufacturing equipment, machine tools, metrology equipment, robotics and factory automation

Benefits

Enables automated industrial equipment to move with greater speed and precision, supporting the evolving needs of advanced manufacturing

Renishaw USPs

- Comprehensive range of price-performance
- Practicality: easy installation and lowest cost of ownership
- Picometer fibre laser encoders ideal for wafer inspection
- Leading provider of magnetic encoders for cobots
- Innovators in robot metrology

Contactless encoders for precision motion control

Open optical encoders #2



Fibre laser encoders #1



Magnetic encoders #2



Motion control & calibration for machine tools & robots

Calibration systems #1

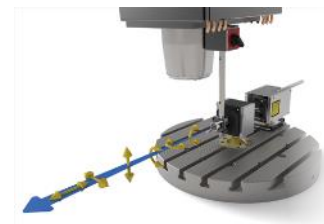

Enclosed encoders NEW



Industrial Automation NEW



Notes

#1 etc = Renishaw's assessment of its market position in each segment

Additive Manufacturing

Industrial metal 3D printing for volume production applications

Emerging



Applications

Volume production of intricate metal components in a wide range of sectors, including medical, aerospace, and consumer electronics

Benefits

AM provides new design possibilities, including opportunities to combine multiple components in production, minimise material use and reduce tooling costs

Renishaw USPs

- The most productive mid-sized laser power-bed fusion machine on the market
- High material properties enabling high-strength parts
- Compact machine footprint
- Lowest cost per part

RenAM 500Q multi-laser AM machine and QuantAM build preparation software



Mass produced medical implants, image courtesy of Permedica SpA



Spectroscopy

Analytical instruments

Established

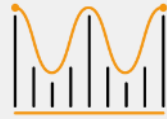

Applications

Raman spectroscopy for materials research in academia, life sciences, pharma, and high-tech manufacturing

Benefits

Non-destructive, highly specific chemical information

Renishaw USPs

- Market-leading inVia research-grade microscope
- Best data in the shortest time
- Complements other laboratory techniques

New InLux™ system enables combined Raman and scanning electronic microscope (SEM) analysis



Neurological

Medical devices

Emerging



Applications

Neurosurgical and drug delivery systems to treat neurodegenerative diseases, cancers, and debilitating conditions

Benefits

Improving patient outcomes through accurate implantable devices

Renishaw USPs

- Proven robot for precision-guided neurosurgery
- Unique drug delivery system supports both acute and chronic infusions

neuroinfuse™ drug delivery system enables treatment of acute and chronic neurological conditions

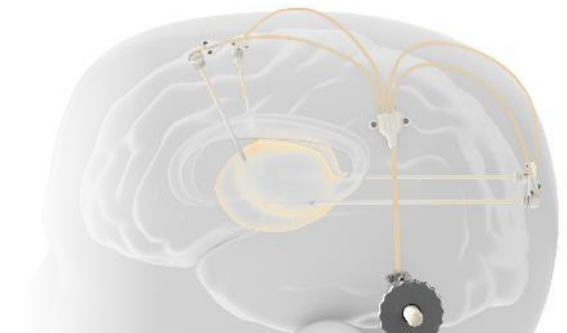

Market segmentation



Opportunities for market share gains in substantial markets

£6b
addressable market ¹

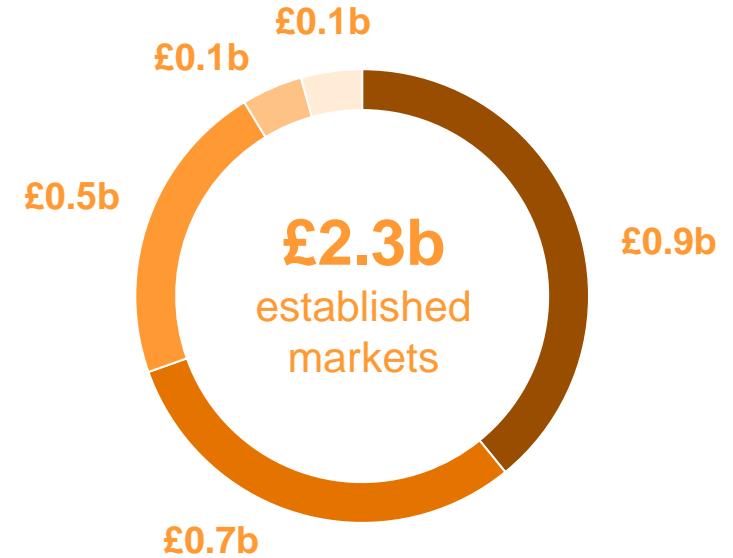
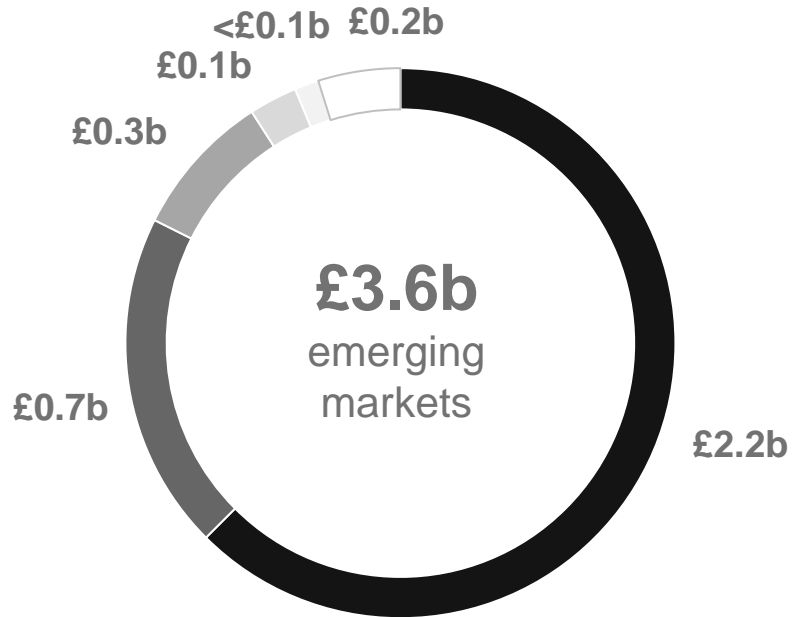

- Metrology systems – shop-floor CMMs, gauging, software
- Metal powder-bed fusion AM machines
- Machine tool precision – enclosed encoders
- Robot precision – calibration
- Smart factory data platforms
- Neurological

- Metrology sensors – CMM, machine tool, styli
- Precision position encoders – open optical & laser
- Robot precision – magnetic encoders
- Machine tool precision – calibration
- Spectroscopy

Notes

1. Unaudited management estimates from a combination of external market research and company market knowledge

Market segmentation & market share

Strong positions and opportunities for market share gains in growing markets

Well positioned in markets growing at >5% p.a.

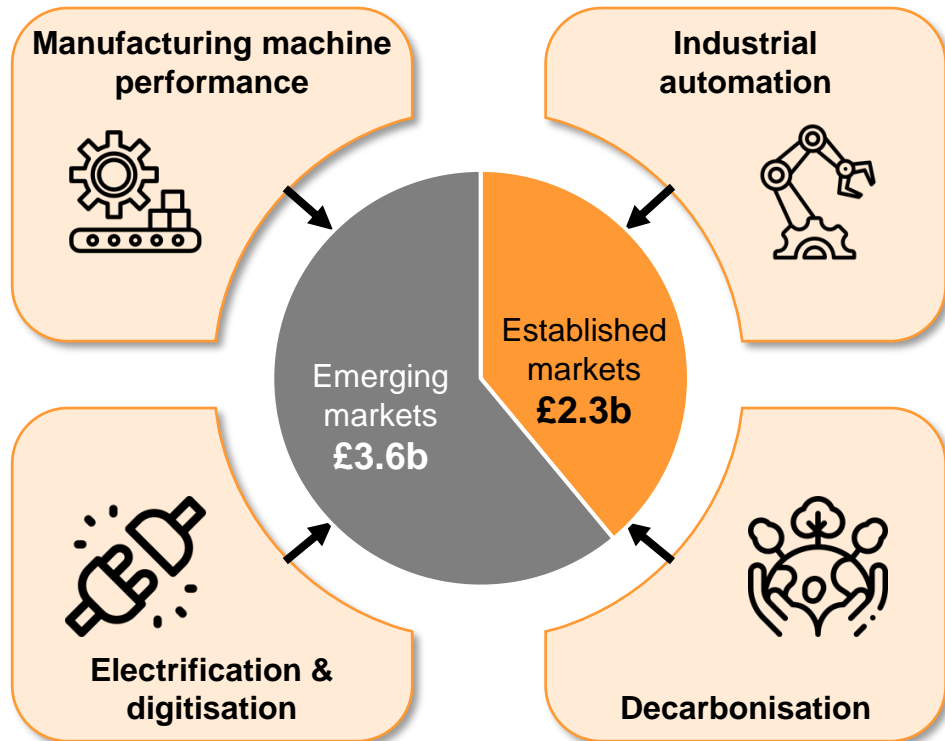

	Emerging	Established
Products	<ul style="list-style-type: none"> IM systems & software AM machines Enclosed encoders Industrial automation 	<ul style="list-style-type: none"> IM sensors Open encoders Calibration Spectroscopy
Market size	£3.6b	£2.3b
FY24 revenue	<20%	>80%
Market share	<10%	>20%

- Structural growth drivers, expected to persist in the long term, underpin growth in our addressable markets
- Strong positions in established markets (#1 / #2)
- Opportunity to gain market share in fragmented emerging markets, many of which are expected to exhibit high growth rates

Customers & competitors

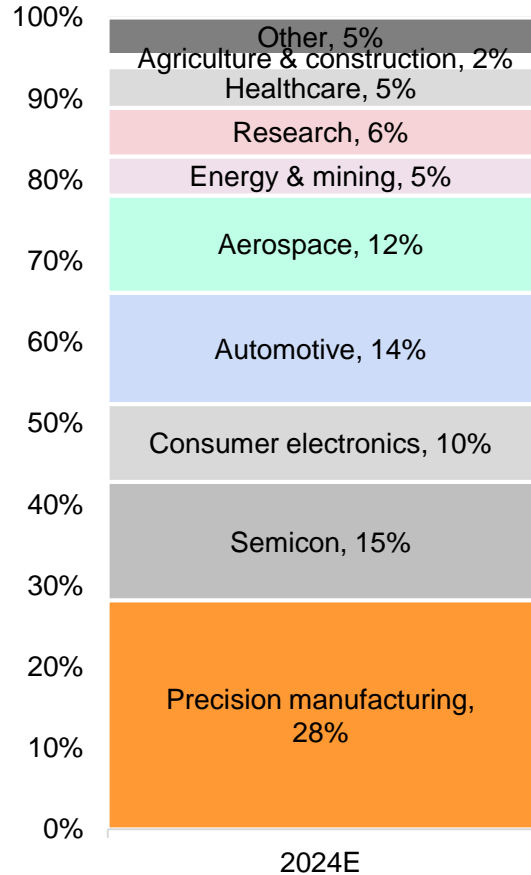

Industries served & routes to market

Broad range of ultimate end user industries



Complementary routes to market

Sales strategies:

- 
Position Measurement
 Encoder sales are dominated by machine builders who integrate encoders into their equipment. By contrast, calibration & industrial automation are end-user driven business
- 
Industrial Metrology
 Mostly machine builder & distributor sales, plus end-user consumables. Exceptions can be found in CMM & gauging systems (capex sales) and machine tool probing (projects)
- 
Other
 Product lines comprise capital goods sales, mostly direct to end-users

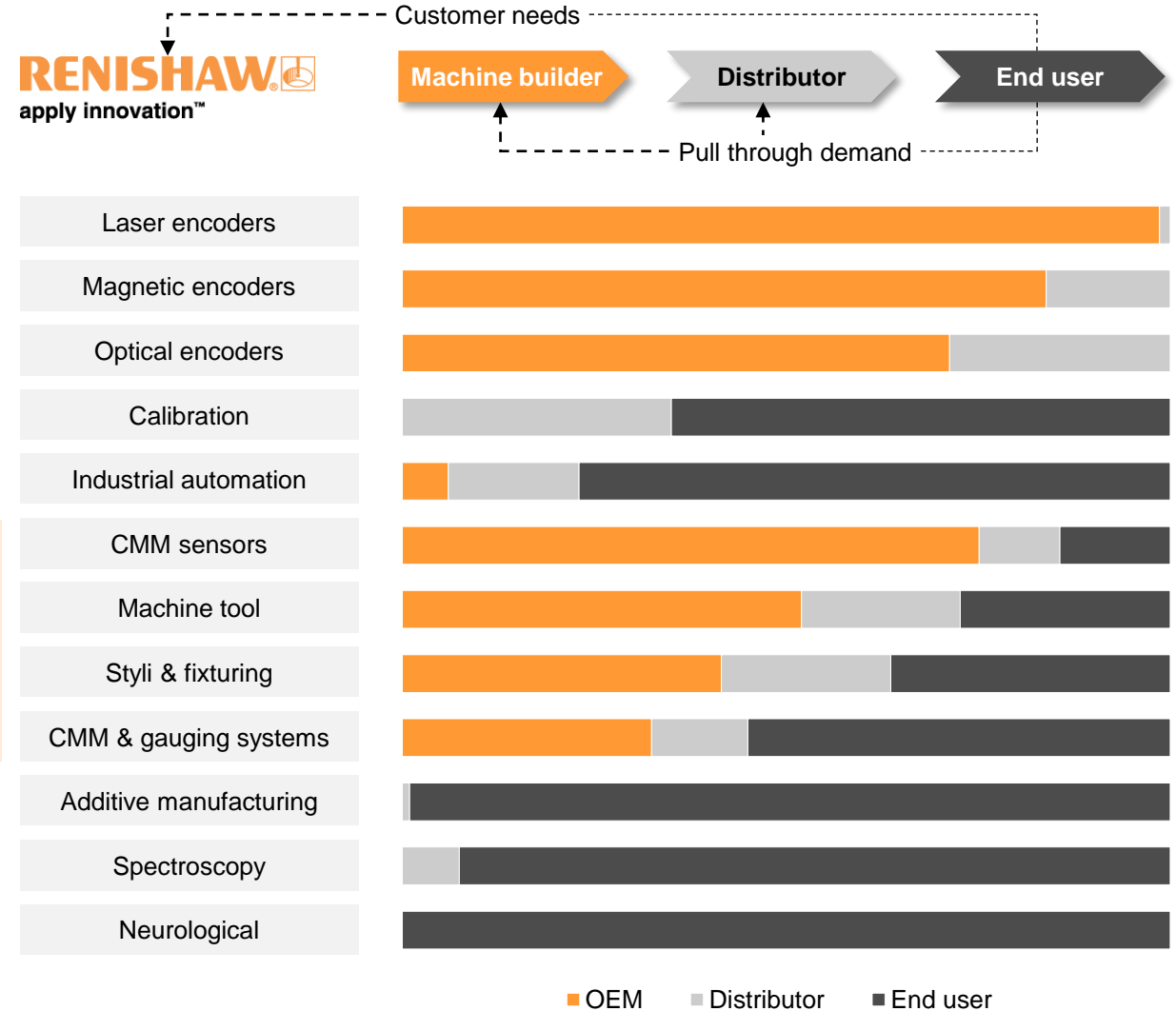

Customer age profile

Reoccurring revenues from machine builders and key end-users

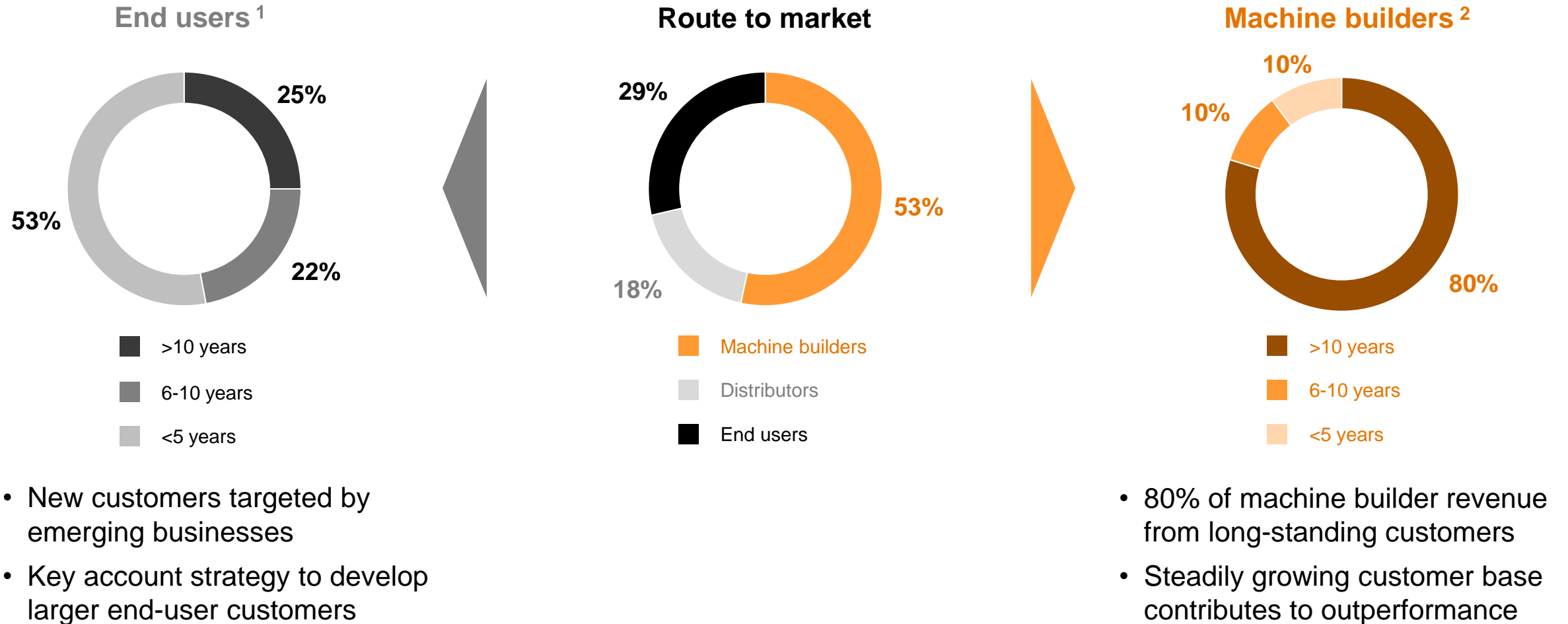

Notes

1. Analysis applies to FY23 sales to end-user customers in Manufacturing Technology product lines
2. FY23 sales to machine builder customers for Industrial Metrology and Position Measurement products

Competitive landscape

Range of rivals, opportunities in fragmented markets & growth territories, rising China threat

Industrial Metrology



Established rivals

- Hexagon
- Carl Zeiss
- Blum-Novotest
- Heidenhain

Market dynamics

- Stable key brand rivalry
- Rising focus on software
- Growth opportunities in emerging geographies
- China becoming more competitive & price-sensitive

Position Measurement



Established rivals

- Heidenhain
- Sensata
- Celera Motion
- Baumer
- Keysight
- Zygo

Market dynamics

- Heidenhain #1 position
- Renishaw steadily gaining share
- Emergence of low-price rivals in China

Additive Manufacturing



Established rivals

- EOS
- SLM Solutions (Nikon)
- Concept Laser (GE)
- Trumpf
- VELO 3D
- 3D Systems

Market dynamics

- Fragmented market
- Low profitability
- Consolidation
- Emergence of low-price Chinese machine builders

Spectroscopy

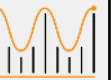

Established rivals

- Horiba
- Kaiser (Endress & Hauser)
- Witec (Oxford Instruments)
- Bruker
- Thermo Fisher

Neurological



- ClearPoint
- Zimmer Biomet

Market growth

Trends in the manufacturing technology ecosystem

Size and growth rates of our underlying markets

Well-positioned in markets growing at >5% p.a.

Key capex market indicators that underpin demand for Renishaw technologies



Machine tool consumption ¹

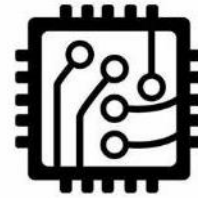
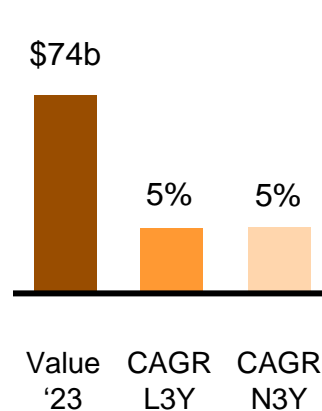

Semiconductor equipment ²

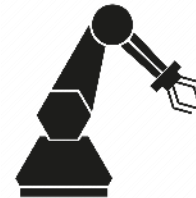
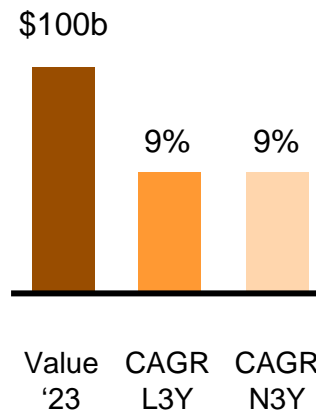

Industrial robotics ³

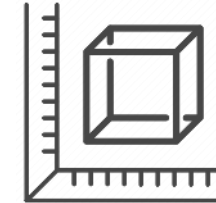
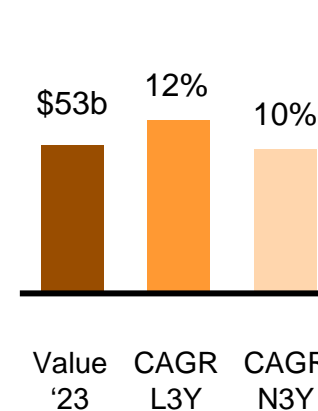

Metal AM equipment ⁴



Laboratory equipment ⁵

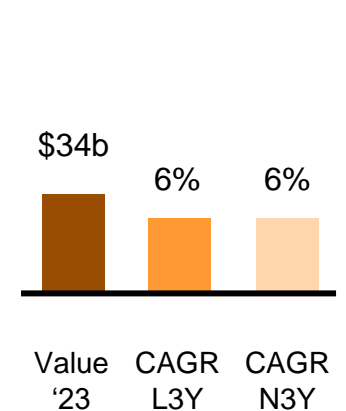

Charts key:

- **Value '23** = estimated global investment in 2023
- **CAGR L3Y** = average growth over last 3 years
- **CAGR N3Y** = forecast average growth over next 3 years

Sources

1. Oxford Economics Global Machine Tool Survey 2022
2. SEMI / Statista
3. [Global Industrial Robotics Market Report \(2022 to 2030\) - \(globenewswire.com\)](https://www.globenewswire.com)
4. Average value from a range of market reports
5. [Laboratory Equipment Market Report | Global Forecast From 2023 To 2031 \(dataintelo.com\)](https://dataintelo.com)

Trends in the manufacturing technology ecosystem

Historic capex trends and medium-term forecasts

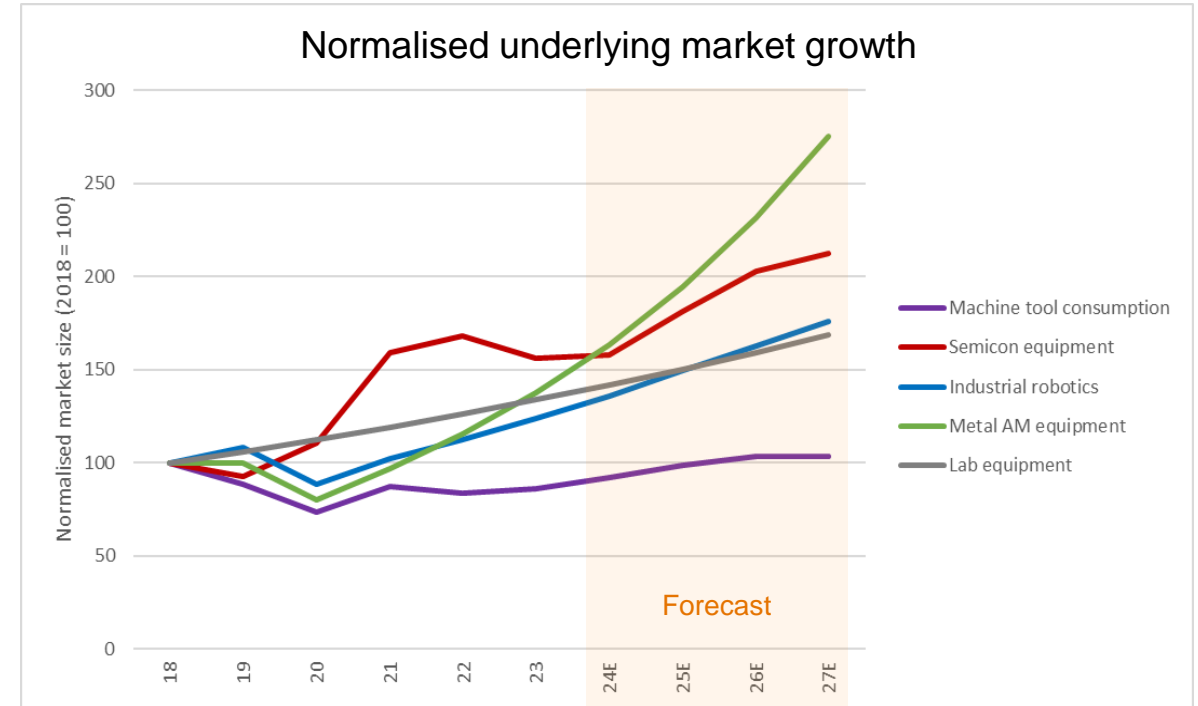
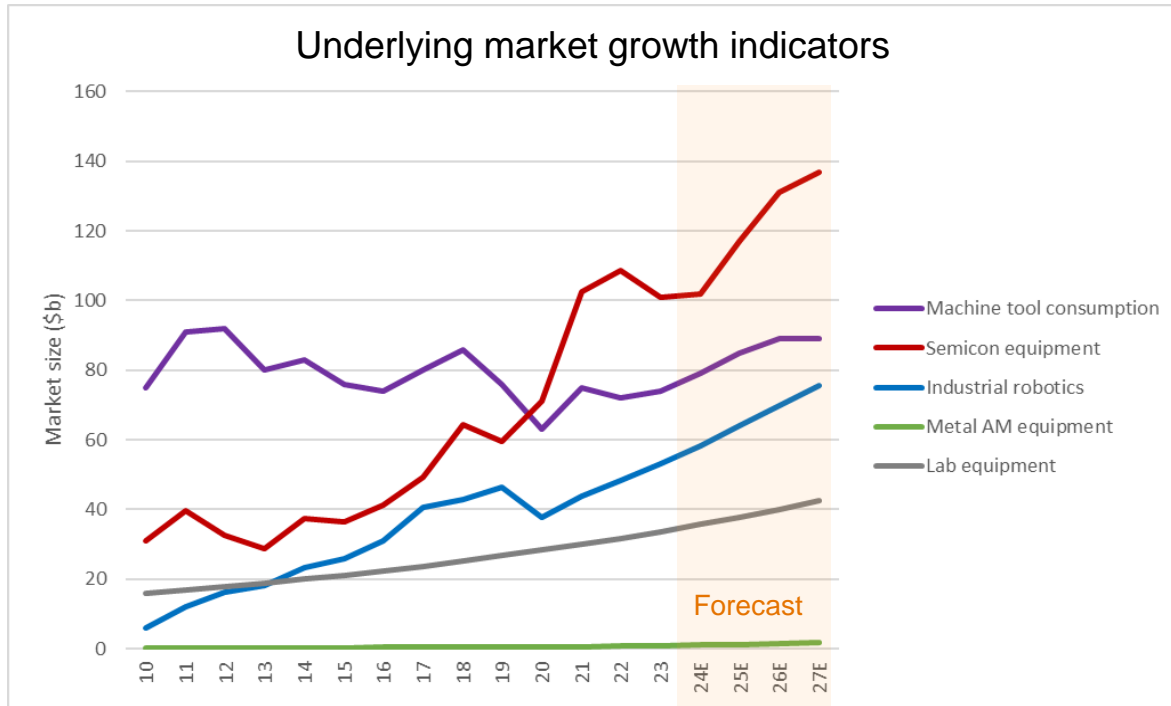

- Machine tool demand has been roughly stable since 2010 – Renishaw MT probing growth achieved through rising fitment levels
- Semiconductor manufacturing equipment now the largest asset class, expected to grow 24% over next 2 years, but likely to remain cyclical
- Robot investment continues to grow strongly and may overtake machine tool investment in the years ahead
- Additive manufacturing is a much smaller asset class today, but has the highest recent and projected growth rates
- Lab equipment grows at a steady 6%, with minimal cyclicity

Attractive markets growing at >5% p.a.

Structural growth drivers underpinning sustained market growth

MANUFACTURING TECHNOLOGY

Manufacturing machine performance



Relentless drive to improve the **precision, speed and capability** of manufacturing equipment to make the advanced products of the future

Industrial processes are becoming more **automated** as manufacturers grapple with skilled labour shortages and aim to become more productive

Industrial automation

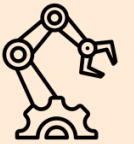

CHANGES IN WIDER SOCIETY



Electrification & digitisation

As the world becomes more **electrified and connected**, we are seeing sweeping changes in the transportation, electronics and semiconductor industries

The drive to **decarbonise** is forcing every manufacturer to rethink how we design, make and support our future products to minimise our environmental impact



Decarbonisation

Structural market drivers – machine performance

Improve the precision, speed and capability of manufacturing equipment



CASE STUDY: KOVERY linear motors

- Linear motors are widely used in electronics & semiconductor manufacturing & machine tools
- KOVERY specialises in high-speed and ultra-high-precision linear motors, with minimal velocity ripple & bearing wear
- Renishaw QUANTiC™ encoders meet these demanding performance requirements, as well as providing:
 - Excellent cost performance & delivery
 - Fast & easy installation
 - Expert technical support

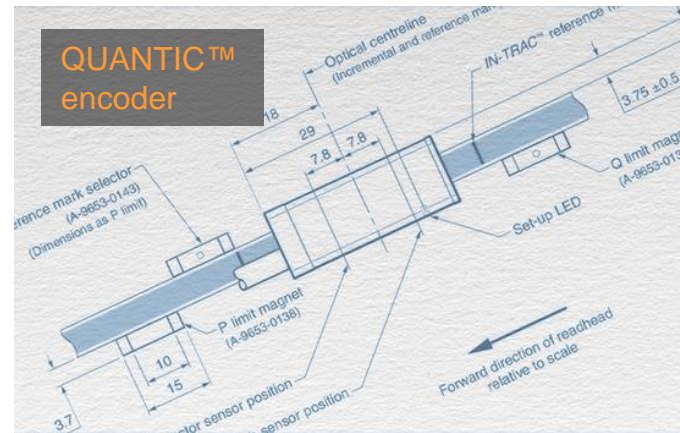

Structural market drivers – industrial automation

Intelligent process control to automate machining & boost productivity



CASE STUDY: automated gauging

- High-volume component machining is increasingly automated due to labour shortages and cost pressures
- Automation requires metrology to detect and compensate for process variation and drift
- EQUATOR™ is the leading shop-floor flexible gauge, widely used in automotive, aerospace and consumer electronics production
- EQUATOR is often integrated into robot-loaded machining cells and can provide fully automated feedback to keep processes under control

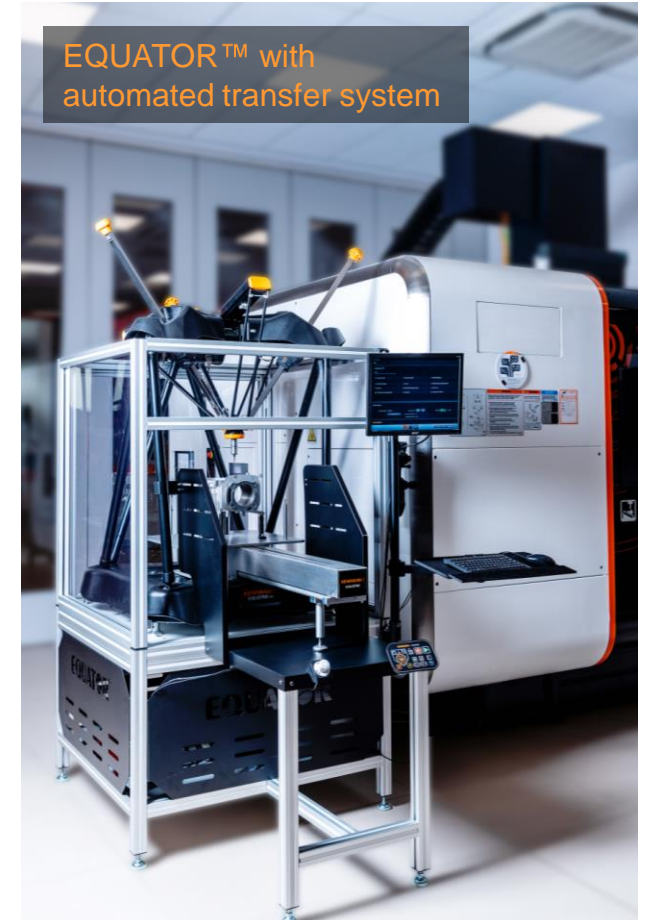
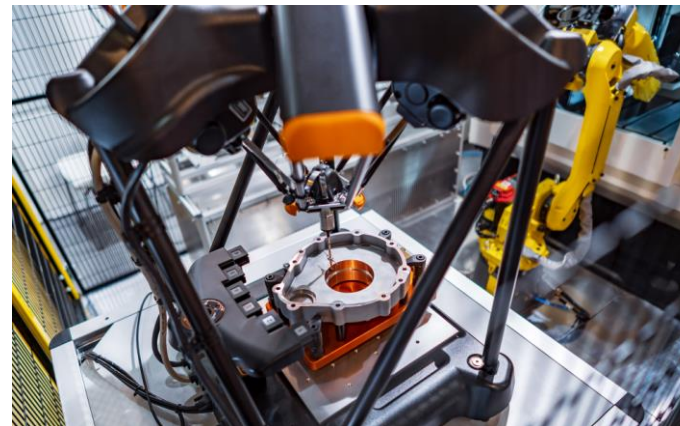
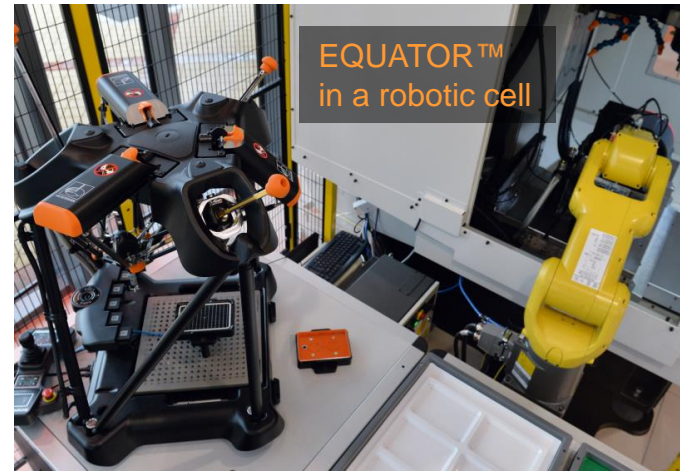

Structural market drivers – electrification

EV production creates new measurement challenges



CASE STUDY: multi-sensing

- Complex products require comprehensive inspection using multiple techniques
- REVO® 5-axis multi-sensor inspection system combines contact sensing, video, fringe, surface, temperature and thickness sensors
- High-throughput inspection in a single automated process

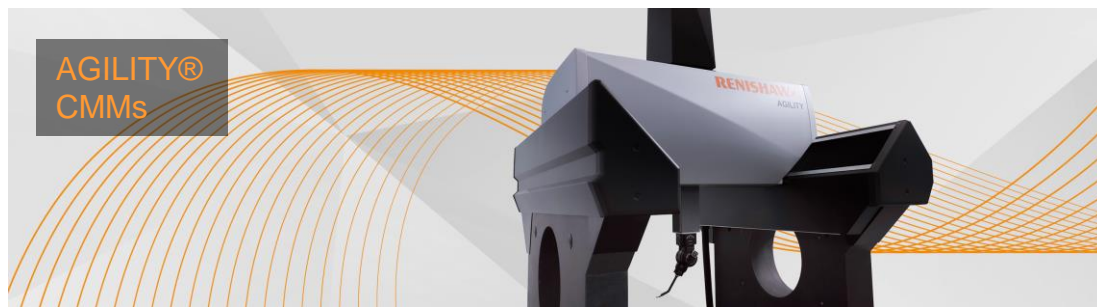
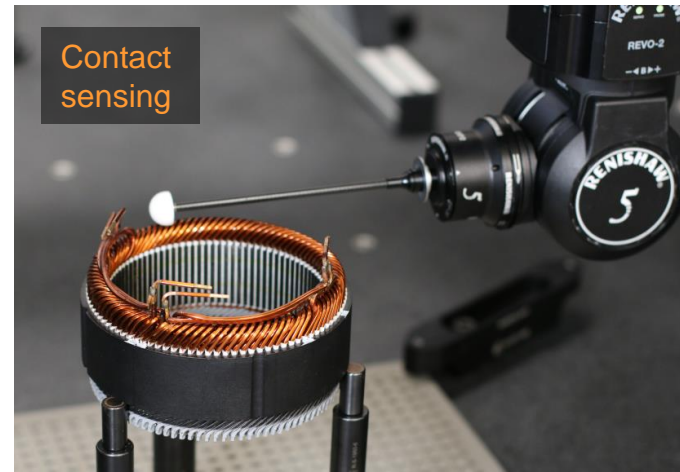

Structural market drivers – decarbonisation

Designing innovative products with a low carbon footprint



CASE STUDY: additive servo valves

- Hydraulics produce twice as much CO₂e emissions as the aerospace industry – valves are typically only 23% efficient
- DOMIN Fluid Power is disrupting the hydraulics industry by redesigning servo valves using additive manufacturing
- Better performing and more sustainable
- Additive manufacturing enables lower material consumption & embodied carbon
- Over its lifetime, each valve could save multiple tonnes of CO₂e

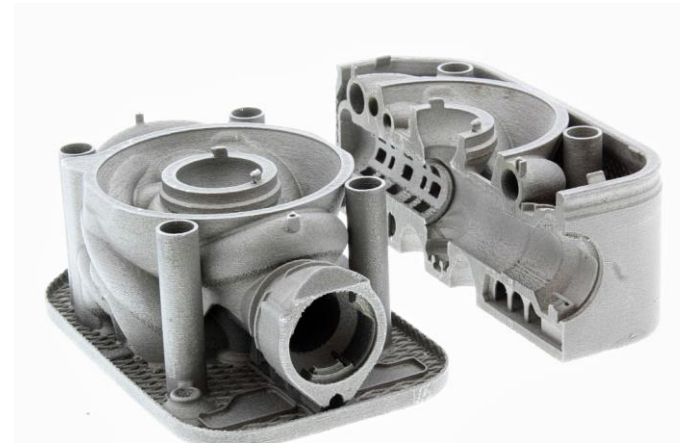

Markets & competitive position

Value creation model

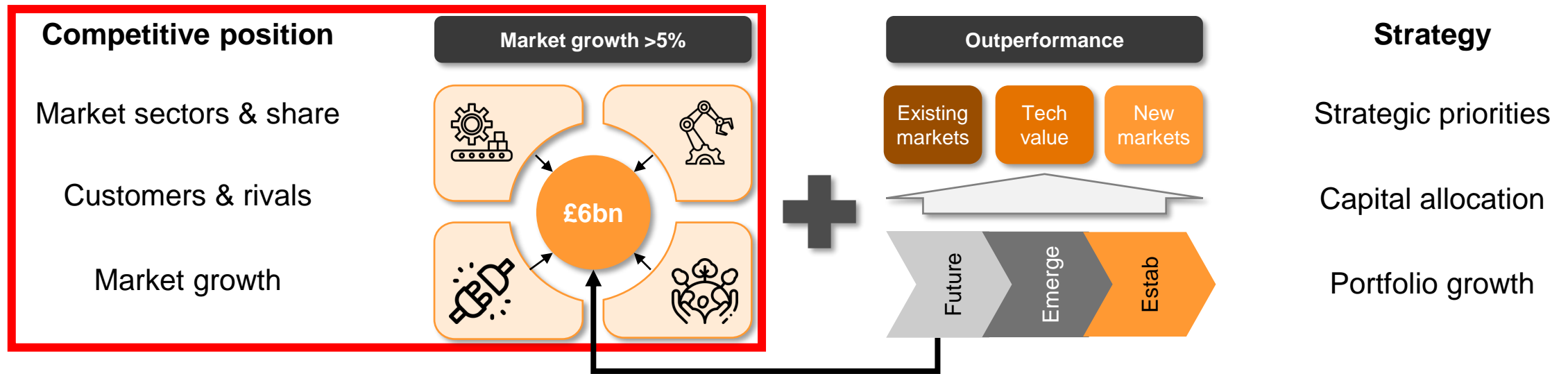

Q&A

Marc Saunders

Director of Group Strategic Development



Growing in existing markets

Steve Oakes

Director of Position Measurement

Jamie Buckingham

**Director & General Manager
Machine Tool Products Division**



Strategy to drive consistent outperformance

3 areas of strategic focus to combat competition & grow our market share

Strategy driving consistent outperformance

Growing in existing markets



**Increase
revenue per
machine tool**



**Win new
machine builder
customers**

Increasing technology value



**Build
systems
sales**



**Expand
software
business**



**Smart
factory
solutions**



**Diversify into
close-adjacent
markets**

Strategic
priority

Sensors for manufacturing & measurement equipment

Products for machine builders in a range of manufacturing sectors

Established
Emerging

Component manufacturing

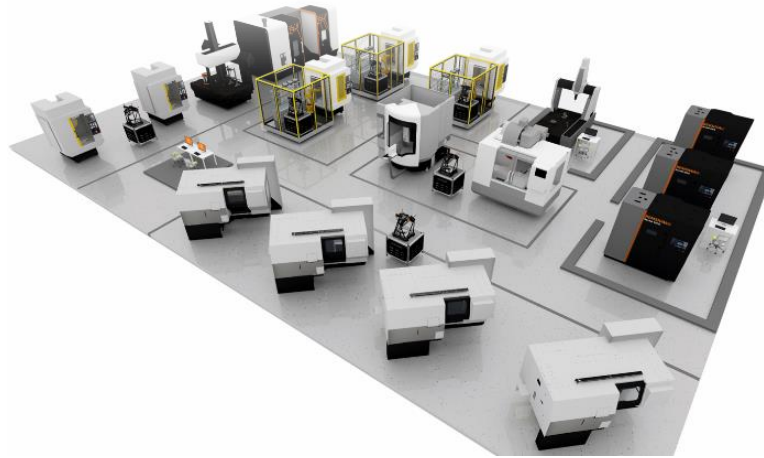

Semicon manufacturing



Robots & automation



CMM sensors



Machine tool probes



Enclosed encoders



Calibration



Open optical encoders



Fibre laser encoders



Magnetic encoders



Goals

Component manufacturing

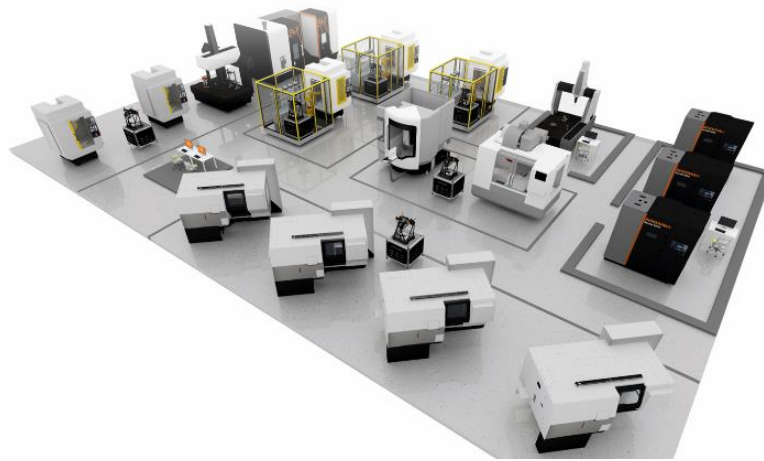

Increase revenue per machine tool

Grow sensor revenues by driving up fitment levels and increasing 'share of wallet'

Semicon manufacturing



Grow machine builder customer base

Secure 'design wins' at new and existing customers with superior products and service to drive reoccurring revenue streams

Robots & automation





Machine tool growth opportunities

Opportunities to increase revenue per machine tool

Established

Emerging

CNC process automation

Machine tool probes



- £0.4b market ¹
- Leading position in machine tool probes
- **Grow the market** through increased probe fitment, higher value probes & software

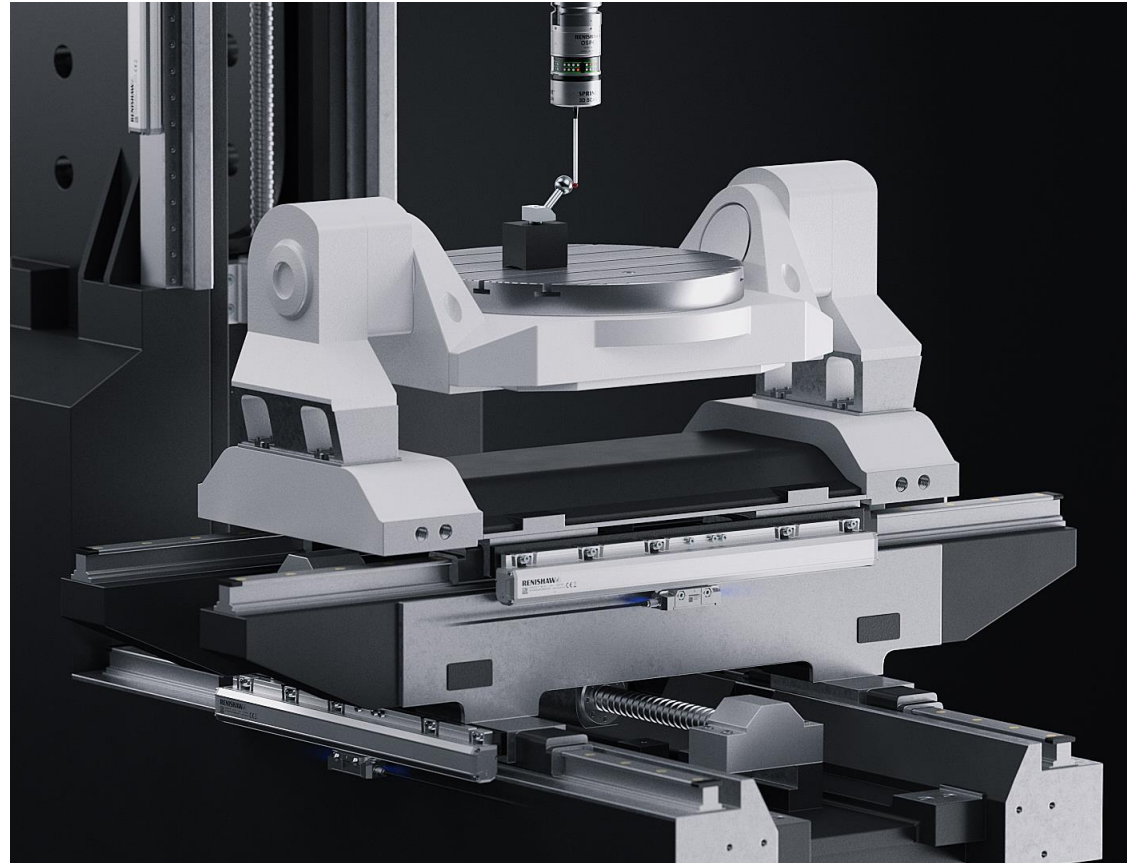

Machine tool accuracy

Enclosed encoders



Calibration



- £0.4b market ²
- Leader in calibration, recent entrant in encoders
- **Gain share** in enclosed encoders, grow the complementary calibration market

Notes

1. Management estimate for total size of machine tool probing market, including related accessories & operational software
2. Management estimate for total size of enclosed encoder & machine tool calibration markets



Rising demand for CNC process automation

Our track record of increasing 'share of wallet'

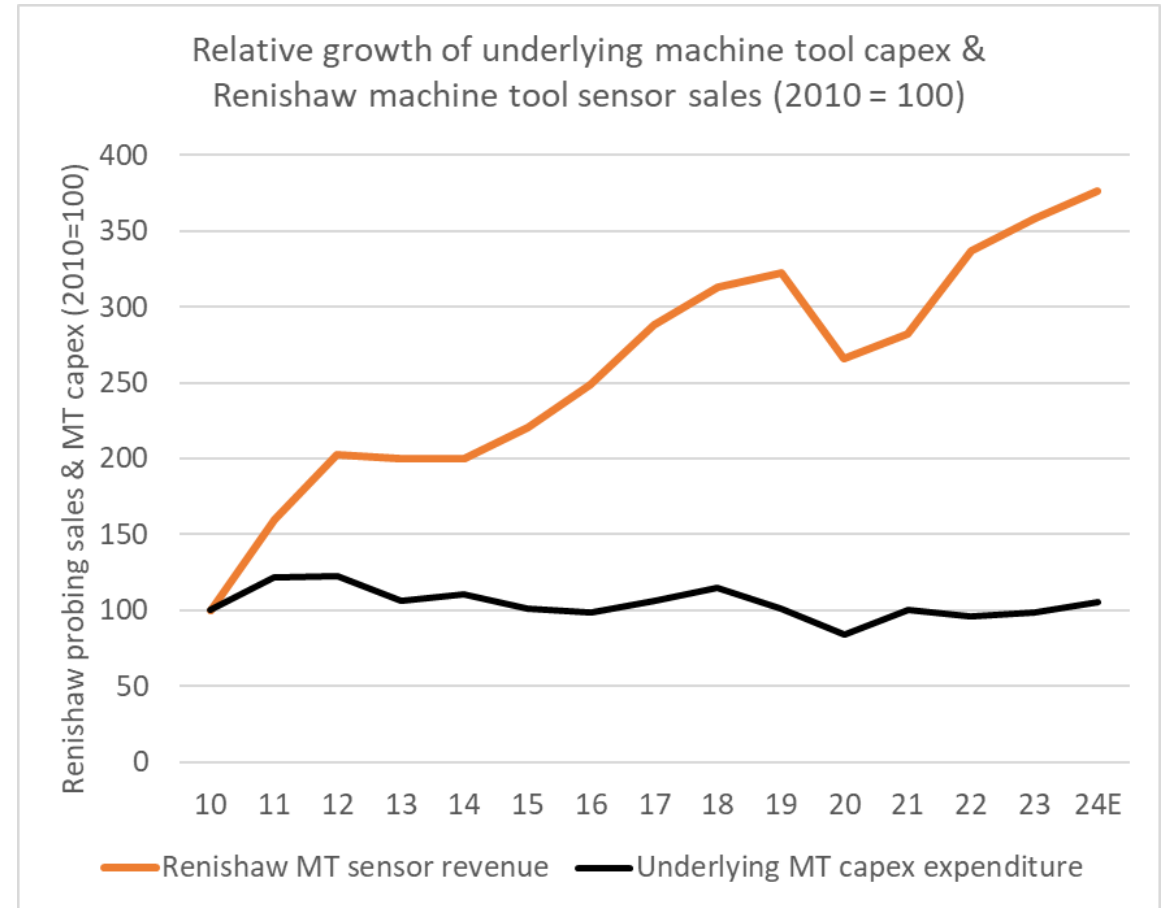
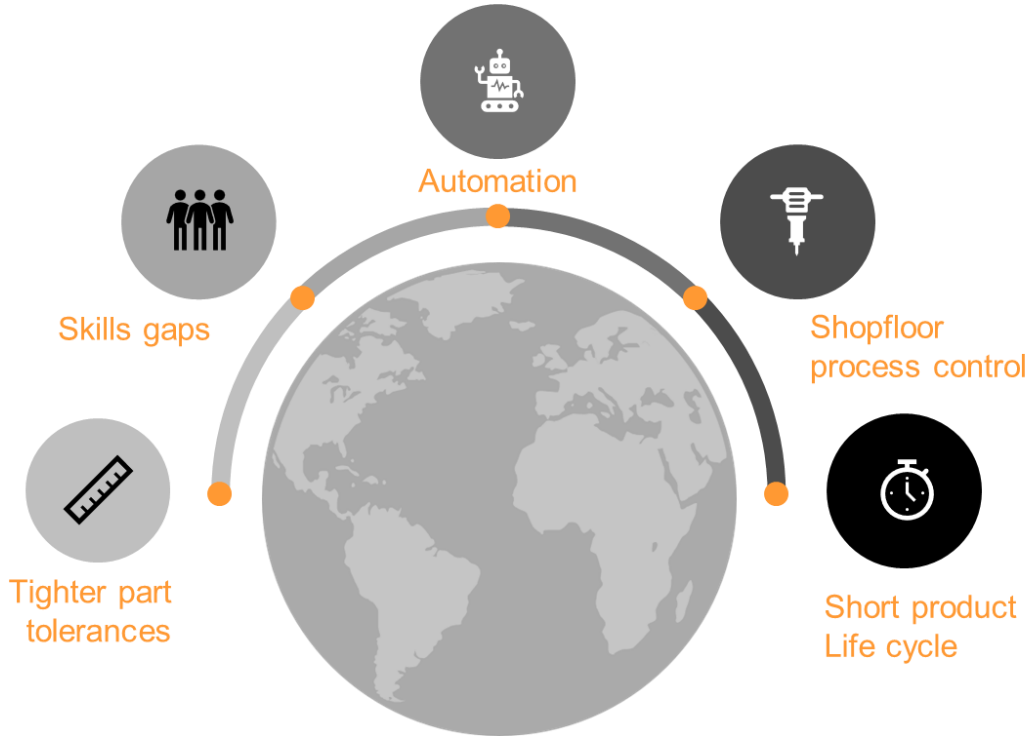

Notes

1. Renishaw MT sensor revenue includes machine tool probes and enclosed encoders, excludes large projects during 2010s
2. Underlying MT capex from: Machine tool apparent consumption from Oxford Economics Global Machine Tool Survey (autumn 2022 forecast)



Building reoccurring machine tool revenues

Long-term customer relationships are critical



80% of machine tool builder revenue from long-standing customers

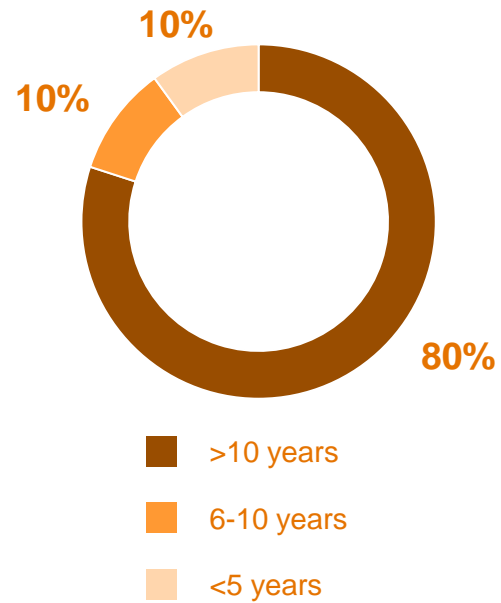

A significant proportion of our growth comes from working closely with machine tool builders to increase probe fitment

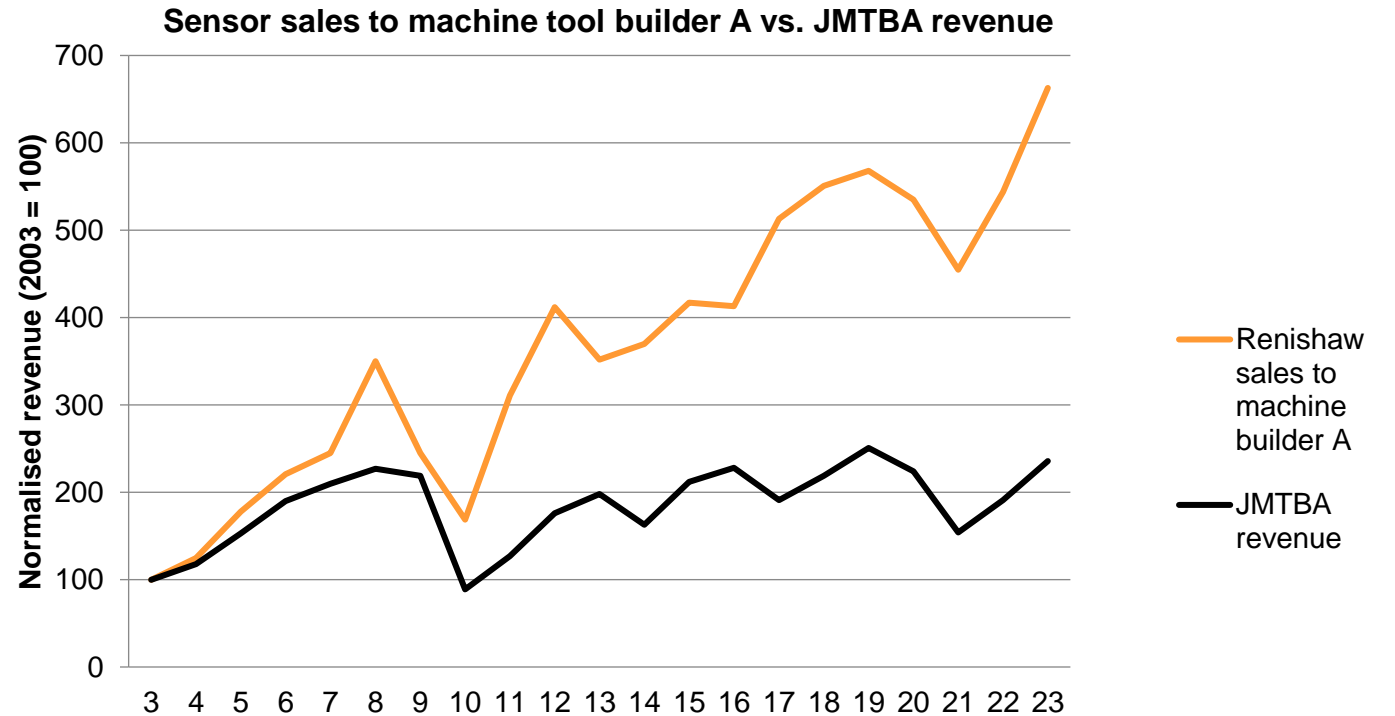

Notes

1. Machine builder A is a large global machine tool supplier with a significant presence in Japan (2003 sales = 100)
2. Japanese Machine Tool Builders Association (JMTBA) publishes detailed records of total sales for its membership, including exports



Building reoccurring machine tool revenues

Augmenting established revenues with new products

Sensor sales to machine tool builder B

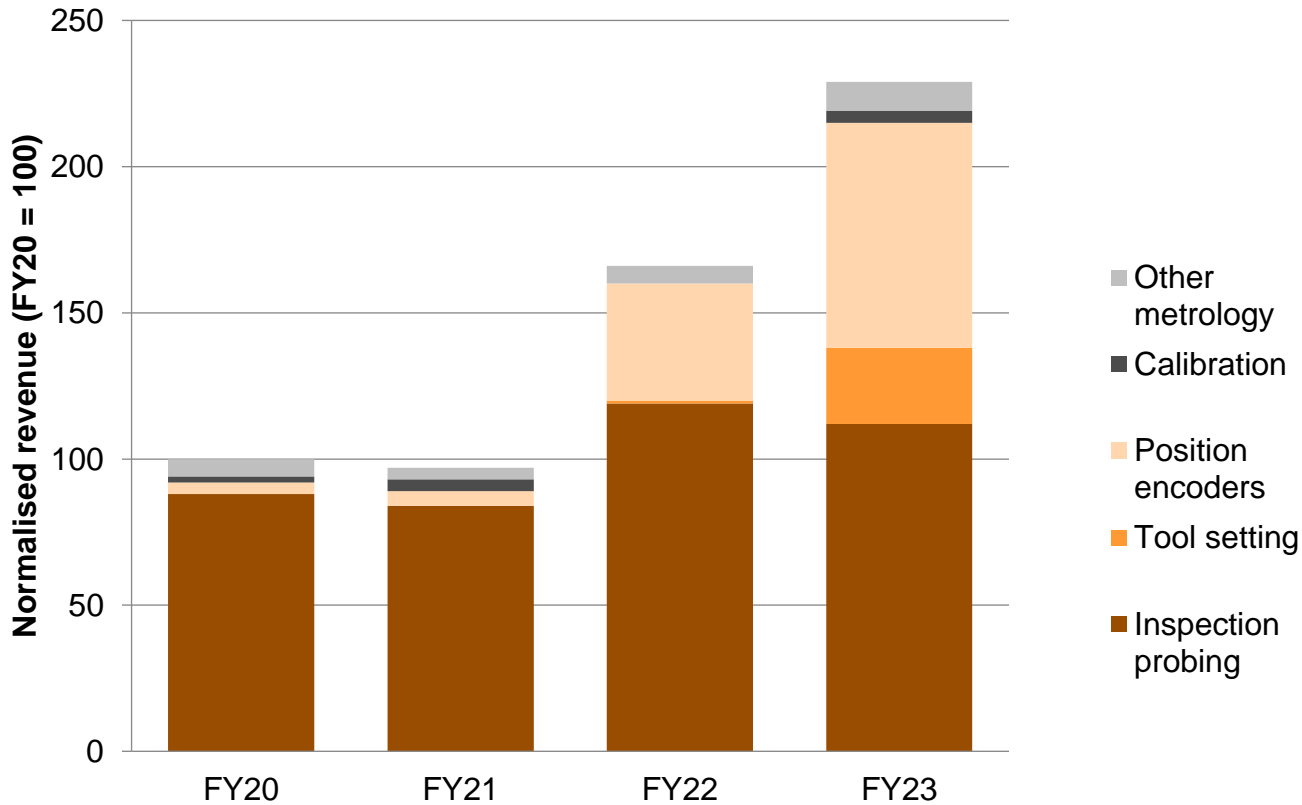

Machine tool precision

Position encoders



Calibration

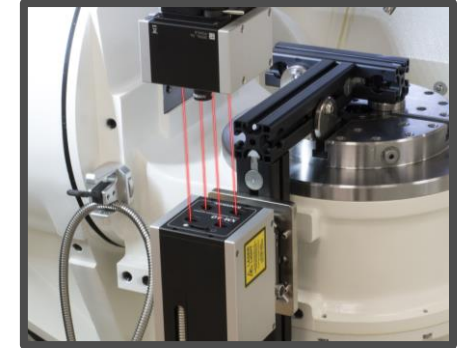

CNC process automation

Inspection probing



Tool setting



Notes

1. Machine builder B is a specialist supplier of tool grinding machines (FY20 sales = 100)



Machine tool sensor innovations

Increase 'share of wallet' with metrology and position sensors

Recent enhancements to our machine tool probes

- **QE series** radio transmission **multi-probe installations** and **extended probe battery life**
- **RMP24-micro** miniature wireless machine tool probe
- **NC4+ Blue** high accuracy laser tool setter
- **Set & Inspect** – accessible shop-floor metrology

Gaining market share in enclosed optical encoders for machine tools

- **FORTiS™** enclosed encoders for linear axis control now in series production at c. 100 machine tool builders
 - no mechanical wear and greater longevity
 - superior dynamic response & vibration resistance
 - 90% reduction in air consumption

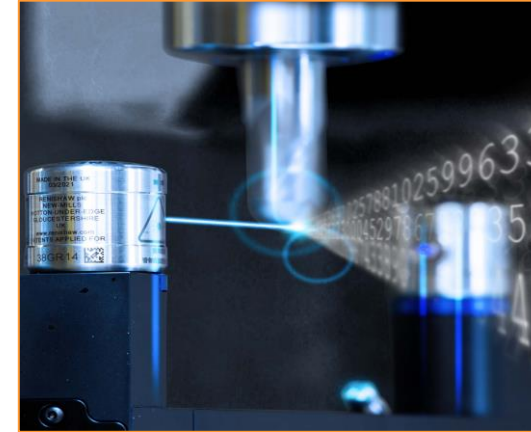

NC4+ Blue laser tool setter



RMP24-micro miniature probe



Set and Inspect probing cycles



FORTiS encoder

Goals

Component manufacturing

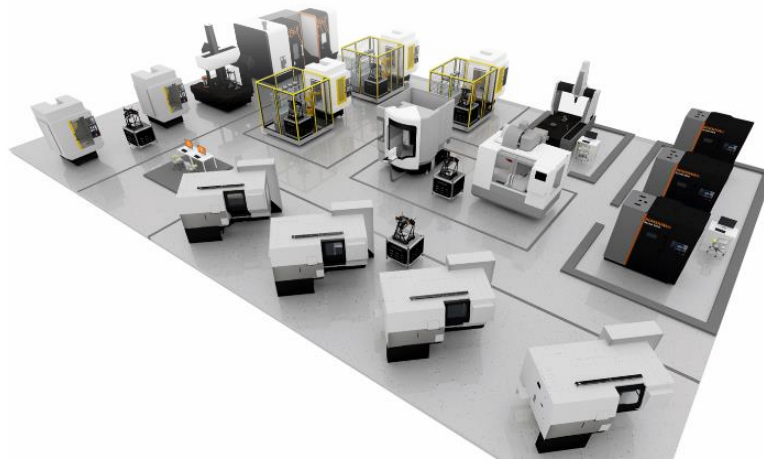

Increase revenue per machine tool

Grow sensor revenues by driving up fitment levels and increasing 'share of wallet'

Semicon manufacturing



Grow machine builder customer base

Secure 'design wins' at new and existing customers with superior products and service to drive reoccurring revenue streams

Robots & automation





Win new machine builder customers

Enhance our strong position in encoders for motion control

Track record of winning new customers to out-grow the underlying market

- Semicon capital equipment 9% CAGR ¹ since 2010, but with significant demand cyclical
- Driven by technology advances, consumer demand, geo-politics
- Renishaw optical & laser encoder growth 11% CAGR ² since 2010, created by growing our machine builder customer base
- How we win:
 - Product performance and practicality
 - Technical and commercial support, stable pricing
 - Responsive to maintain lead-times in peak demand

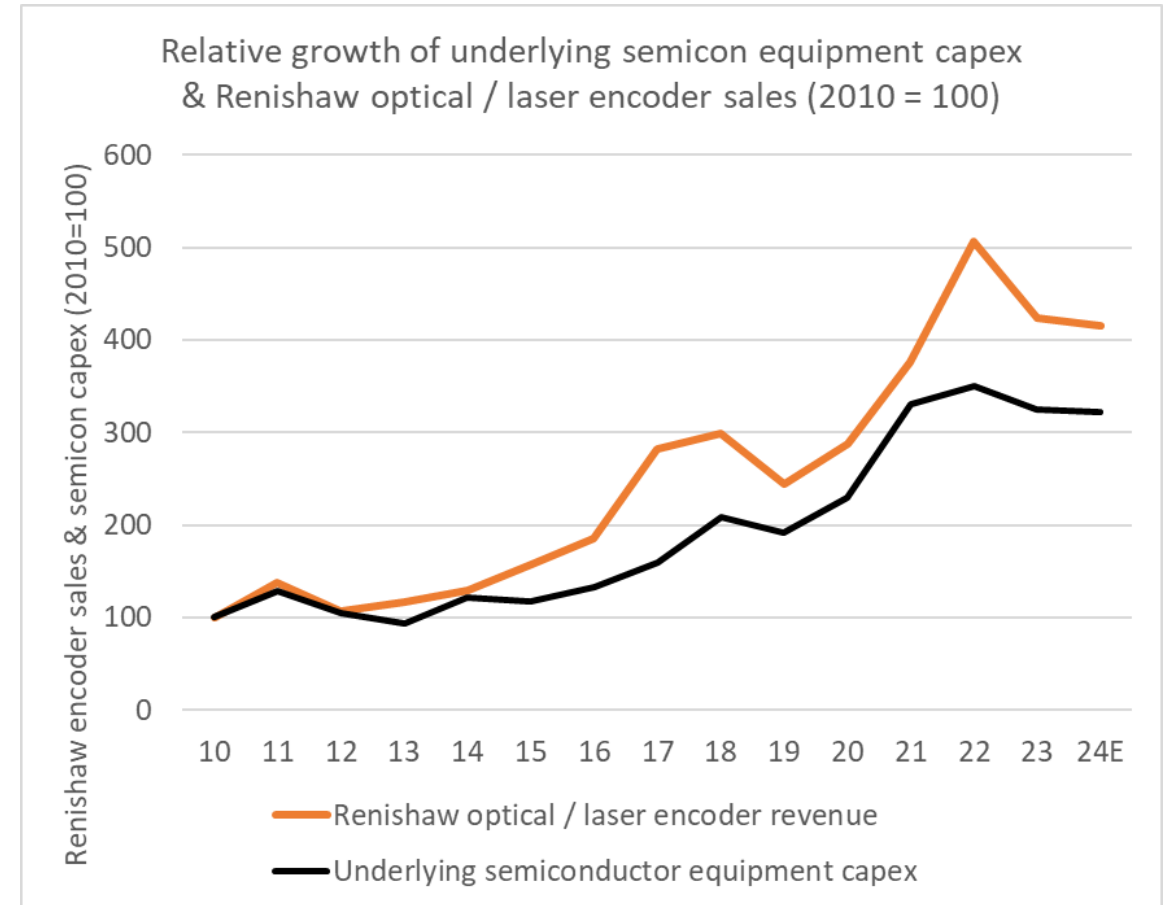

Notes

1. Compound annual growth rate of Semiconductor capital equipment expenditure between 2010 and 2024, source: Statista / Semi.org
2. Compound annual growth rate of Renishaw optical and laser position encoder revenue from FY2010 to FY2024



Semiconductor & electronics manufacturing

Hotspots where Renishaw position encoders are widely deployed

Deposition

Lithography

Etch
Ion implantation

Wafer
dicing

Packaging
Test

PCB drill
Pick & place

Test

Front end

Back end

Electronics

Wafer
movement



Wafer
inspection

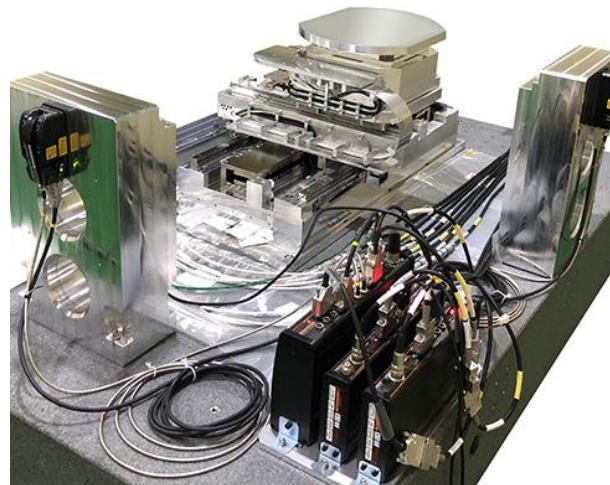

Wire and die
bonding

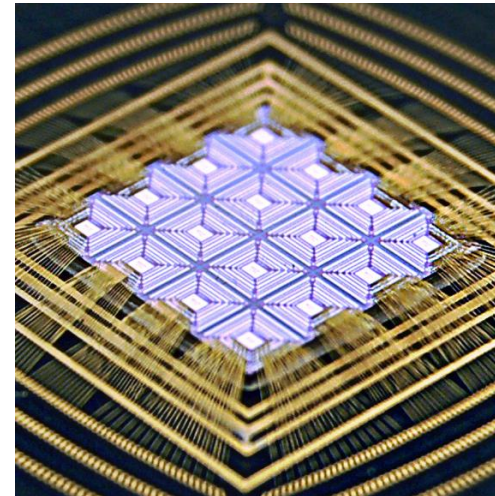

Flat panel
display

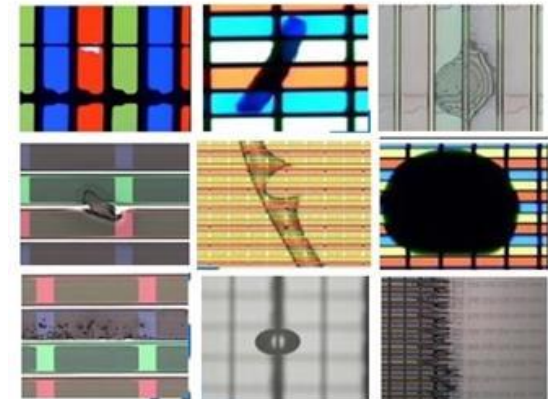



Building reoccurring encoder revenues

New machine builder customers contribute 150-200 bps to annual growth

New customers are a critical contributor to encoder revenue growth

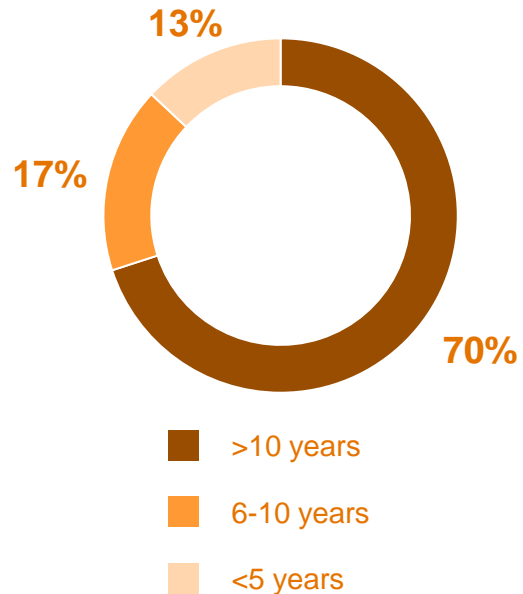

20 years of encoder sales growth¹ at 15% CAGR, driven by reoccurring sales to a growing customer base

Customer age profile of Renishaw encoder sales

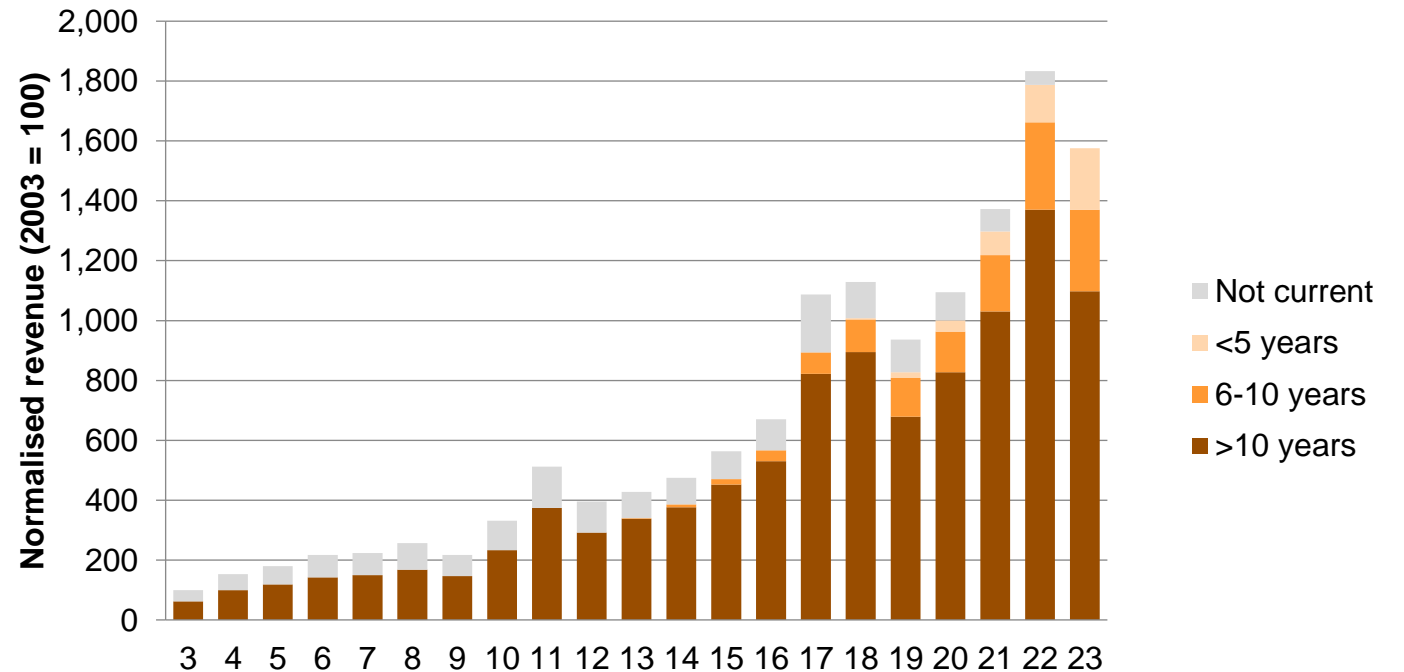

Notes

1. Total encoder revenue (optical + laser + magnetic), grouped by duration since first sale to each customer



Win new machine builder customers

Enhance our strong position in encoders for motion control

INNOVATORS in position measurement

Magnetic encoders



AkSiM-4™ Big Rings for industrial & medical products including robots and rotary tables (launched FY2023)

Optical encoders



CENTRUM™ self-centring disc is easy to fit, de-skilling and reducing installation time by up to 90 % (launched FY2023)

Laser encoders

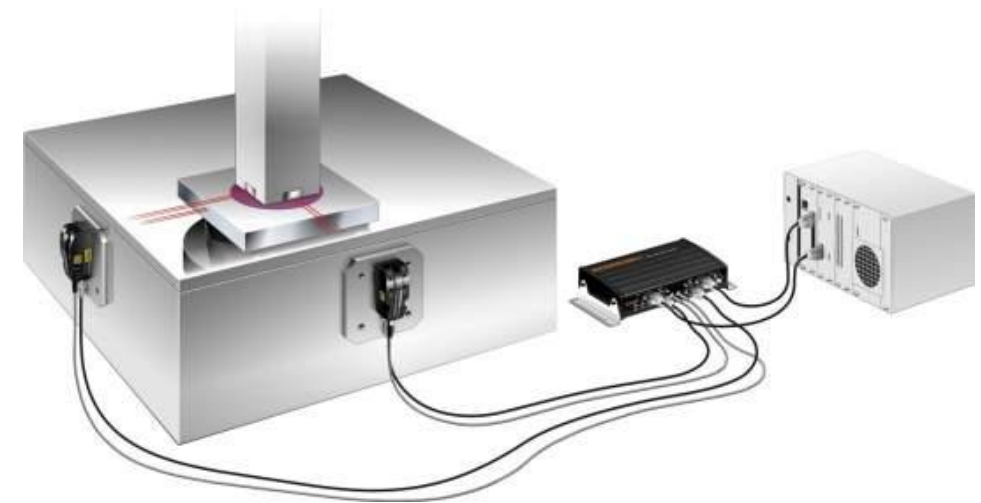

RLE fibre laser encoder with picometer resolution is regularly upgraded to meet the demanding needs of precision semiconductor manufacturing equipment

Robotics | Precision machinery | Semiconductor manufacturing | Metrology

Q&A

Steve Oakes

Director of Position Measurement

Jamie Buckingham

Director & General Manager

Machine Tool Products Division



Increasing technology value

Derek Marshall

Director of Industrial Metrology



S 12129

Strategy to drive consistent outperformance

3 areas of strategic focus to combat competition & grow our market share

Strategy driving consistent outperformance

Growing in existing markets



Increase revenue per machine tool



Win new machine builder customers

Increasing technology value



Build systems sales



Expand software business

Extending into new markets



Smart factory solutions



Diversify into close-adjacent markets

Strategic priority

Increasing technology value in Industrial Metrology

BUSINESS PROFILE

Emerging business with high growth potential within the £2.2b metrology systems market

STRATEGIC FOCUS

Gaining market share in focused niches:

- AGILITY® high-throughput CMMs for at-line and end-of-line inspection
- EQUATOR™ flexible shop floor gauges for intelligent process control
- Enabled by MODUS™ metrology software
- Customers in automotive, aerospace & consumer electronics industries



An introduction to coordinate measuring machines (CMMs)

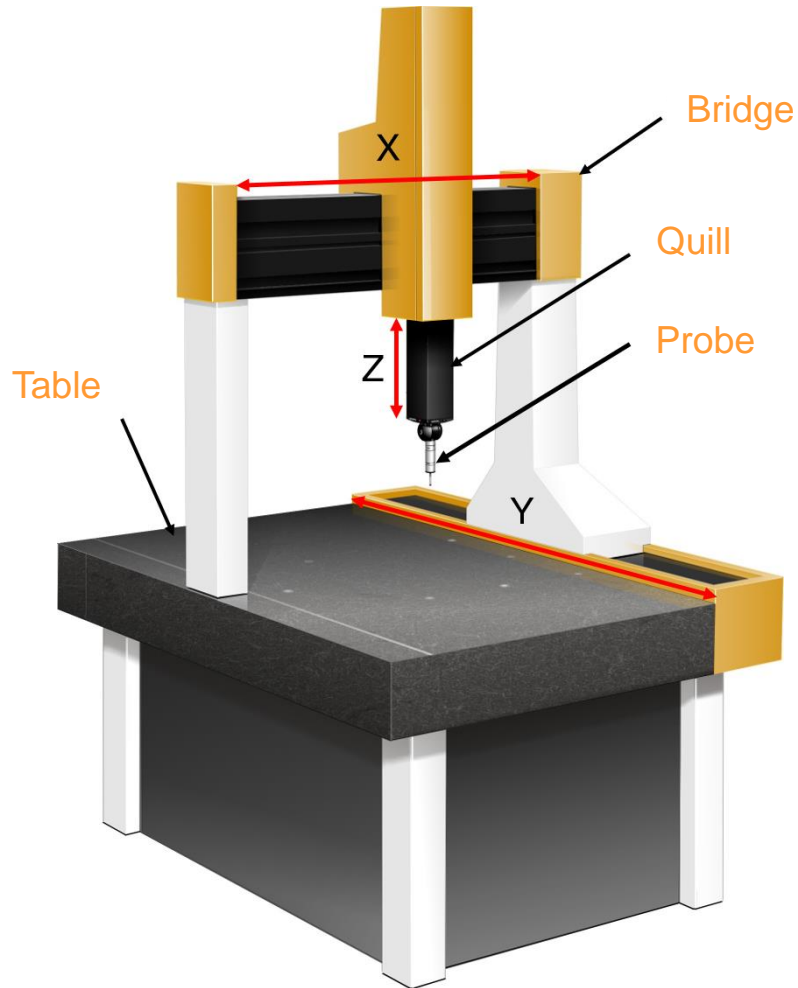

A CMM is a precision measurement platform used to measure component dimensions.

Manufacturers use CMMs to:

- Check goods coming in, before use
- Check the components they are making

CMMs are increasingly being deployed on the shop floor to provide immediate feedback to improve the consistency of manufacturing processes

50 years of CMM sensor innovation

Contact sensors

Motorised probe heads

5-axis technologies

Multi-sensor systems



✓ Precision surface data



✓ Automated inspection



✓ Faster inspection throughput

✓ Fewer stylus set-ups (faster calibration)



+ Fringe

+ Temperature

✓ Complete inspection in a single automated process

REVO® 5-axis multi-sensor metrology

- High measurement throughput
- Flexible feature access
- Scanning, optical & surface sensing

REVO® – an integrated system

5-axis measurement requires more system integration than a traditional CMM head, so to introduce REVO, Renishaw had to develop more CMM component parts:

- CMM controller supporting ability to control 5 axes simultaneously and high data rates
- Ability to work with multiple sensor types (contact, surface finish, vision, ultrasonic thickness)
- Metrology software which is capable of using those technologies to deliver throughput and accuracy

Renishaw also offers other products for CMM builders:

- Position Encoders
- Calibration / machine set-up equipment

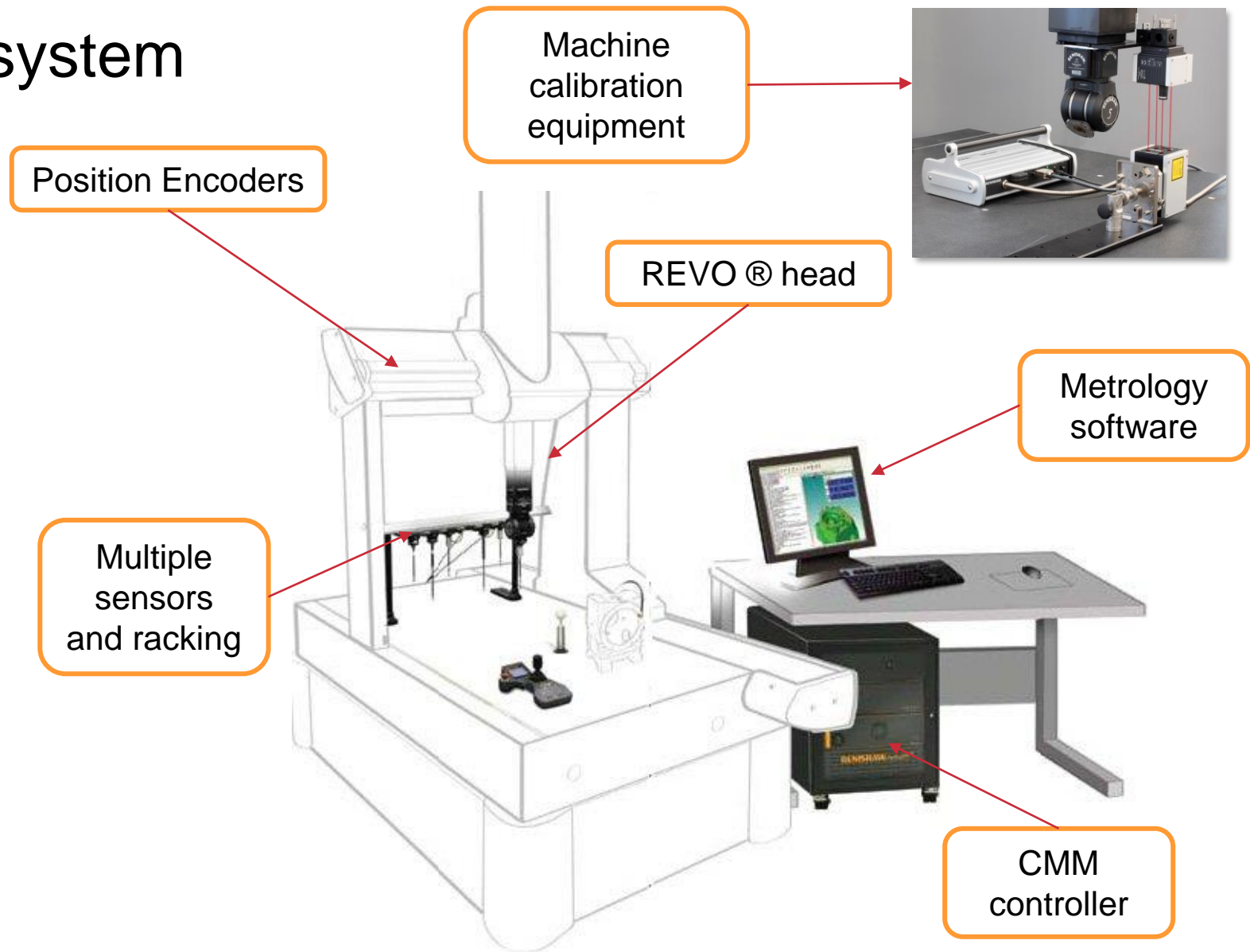

Responding to end-user demand for a complete 5-axis solution

AGILITY® timeline

2005

REVO® available through CMM manufacturers

We continue to strongly support this market today

2010

Renishaw Retrofit

Because of end-user demand, we started to offer retrofits to existing machines (and new machines sold with no sensors or control systems)

2018

Introduction & development of AGILITY®

We introduced our own machine range for shop floor and laboratory use, developing each model in the range for specific customer requirements

2024

Global AGILITY® promotion

We started actively promoting the AGILITY® machine range in key markets globally

Products available

REVO® 5-axis head & contact sensors
UCC CMM controller

MODUS™ software
Additional REVO sensors

AGILITY® CMMs

AGILITY® – optimised for REVO®



Performance highlights

- ✓ Shop-floor series designed for shop-floor environments
- ✓ Delivers rapid results at the point of manufacture
- ✓ Combines multiple operations, using REVO®

Designed for REVO®

- Lightning Drive™ linear motors
- 5-axis measurement extends machine life
- Controlled using Renishaw's UCC
- Elevated drive system for shop-floor protection
- Perfect positioning using Renishaw's VIONiC™ encoders

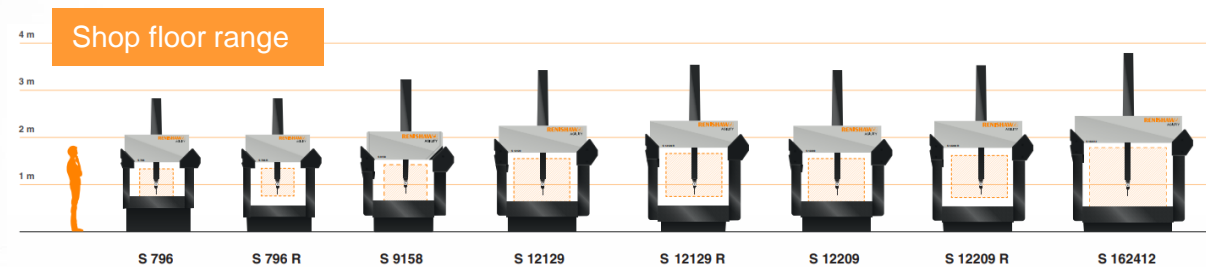

REVO® applications – EV motors

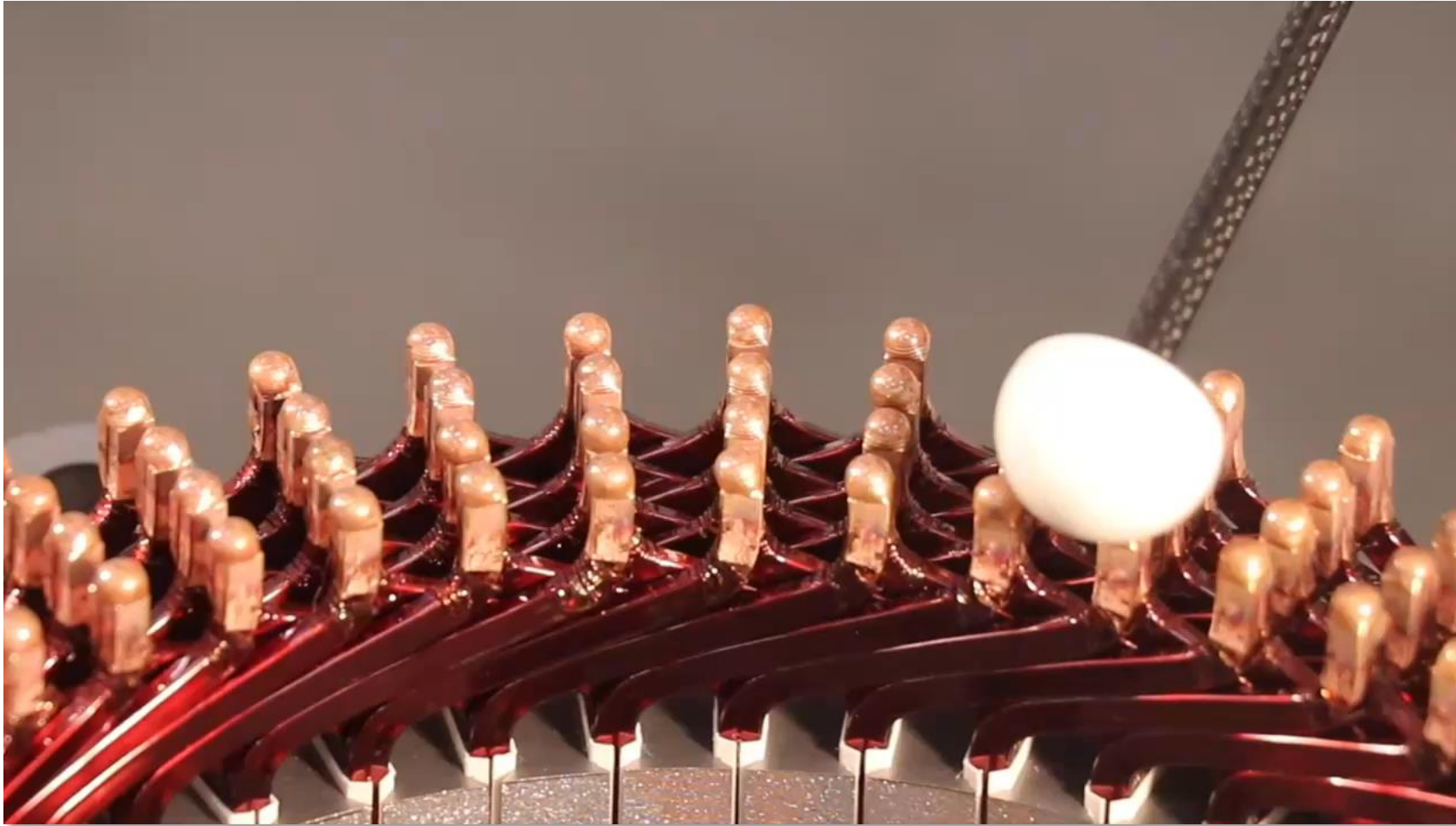

EV motor hairpin inspection

- Scanning weld heights
- Rapid identification of maximum height
- 5-axis contact scanning provides rapid inspection on the same platform as other geometric checks

REVO® applications – EV stators

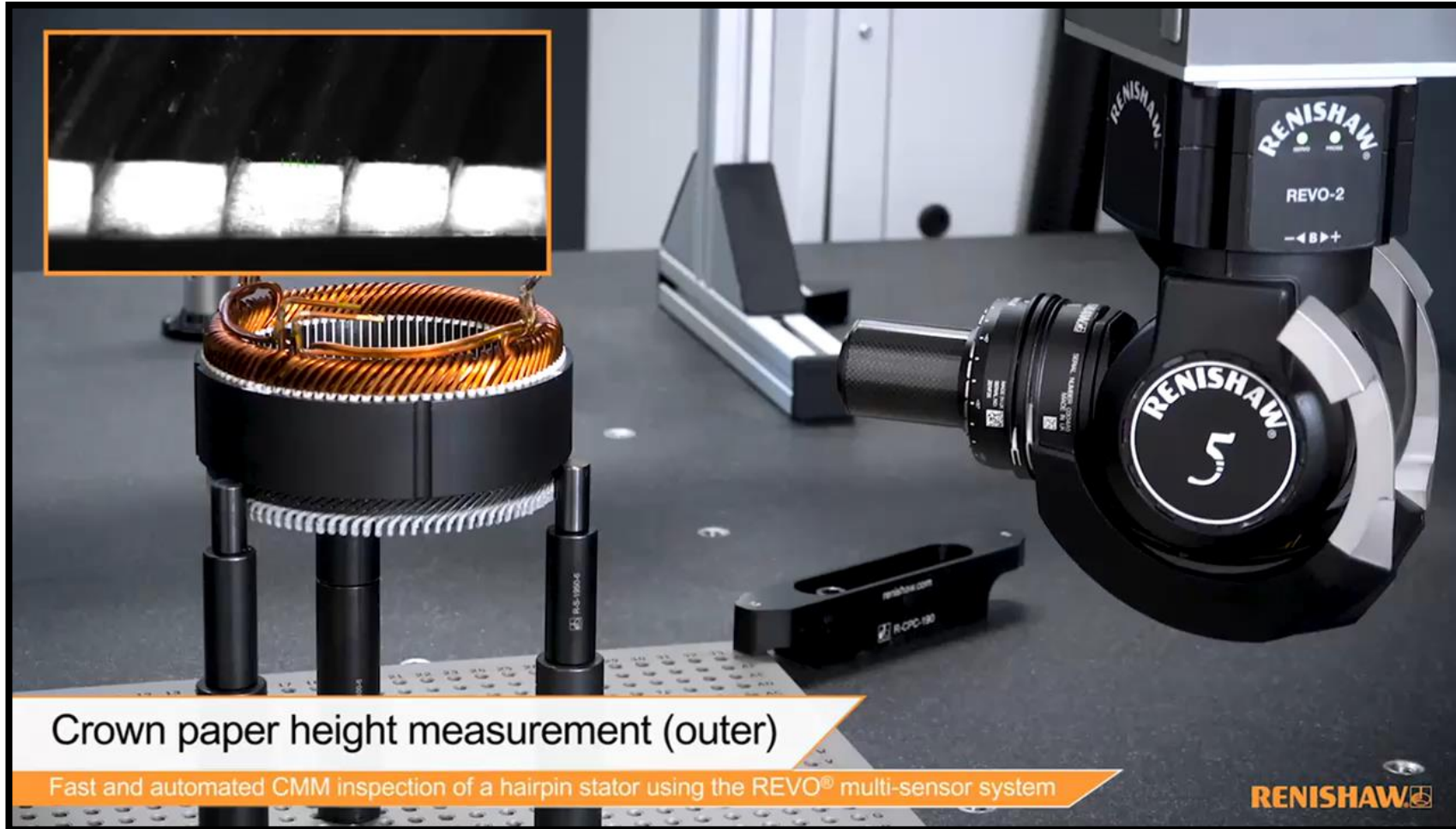

EV stator inspection

- Measure paper heights & condition
- Check top and bottom on inside and outside of part
- Angle Change Mirror (ACM) allows checking inside of part

AGILITY applications – ICE powertrain

In-line fully automated robot-loaded inspection of gearbox case

- Multi-machine installation with automation, integration and application programming

[Robot loading \(video\)](#)

[Inspection process \(video\)](#)

RENISHAW®

RENISHAW®

Increasing technology value in Industrial Metrology

BUSINESS PROFILE

Emerging business with high growth potential within the £2.2b metrology systems market

STRATEGIC FOCUS

Gaining market share in focused niches:

- AGILITY® high-throughput CMMs for at-line and end-of-line inspection
- EQUATOR™ flexible shop floor gauges for intelligent process control
- Enabled by MODUS™ metrology software
- Customers in automotive, aerospace & consumer electronics industries



Q&A

Derek Marshall

Director of Industrial Metrology



Increasing technology value

Louise Callanan

Director of Additive Manufacturing

Matt Parkes

AM Strategic Development Manager

Strategy to drive consistent outperformance

3 areas of strategic focus to combat competition & grow our market share

Strategy driving consistent outperformance

Growing in existing markets



Increase revenue per machine tool



Win new machine builder customers

Increasing technology value



Build systems sales

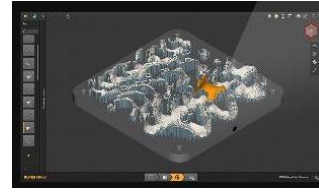

Expand software business

Extending into new markets



Smart factory solutions



Diversify into close-adjacent markets

Strategic priority

Additive manufacturing topics

Market opportunity

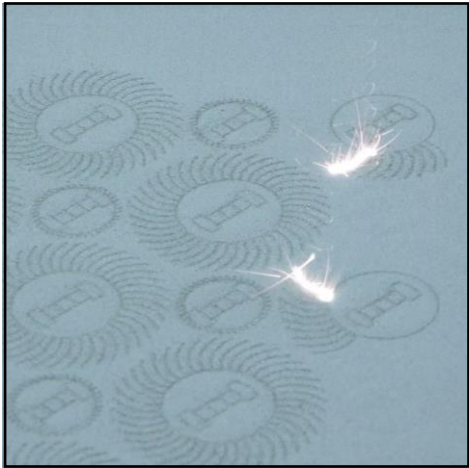

- Market segmentation and size
- Growth drivers

Our strategy



- Volume AM production
- Key accounts
- Lowest cost-per-part

AM adoption



- Innovative solutions to overcome growth constraints

Future platform

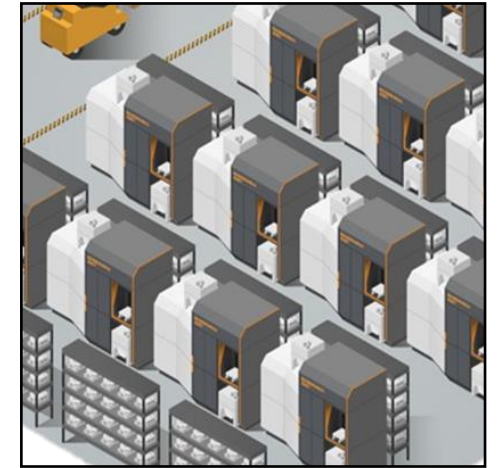

- Next step towards even lower part costs

Laser Powder Bed Fusion

Largest metal AM market

AM is an **£14bn** industry, forecasted to grow at **~20% CAGR** to 2030¹

Our focus is the **£0.7bn** metal powder-bed fusion segment, plus associated services – the largest metal AM technology market

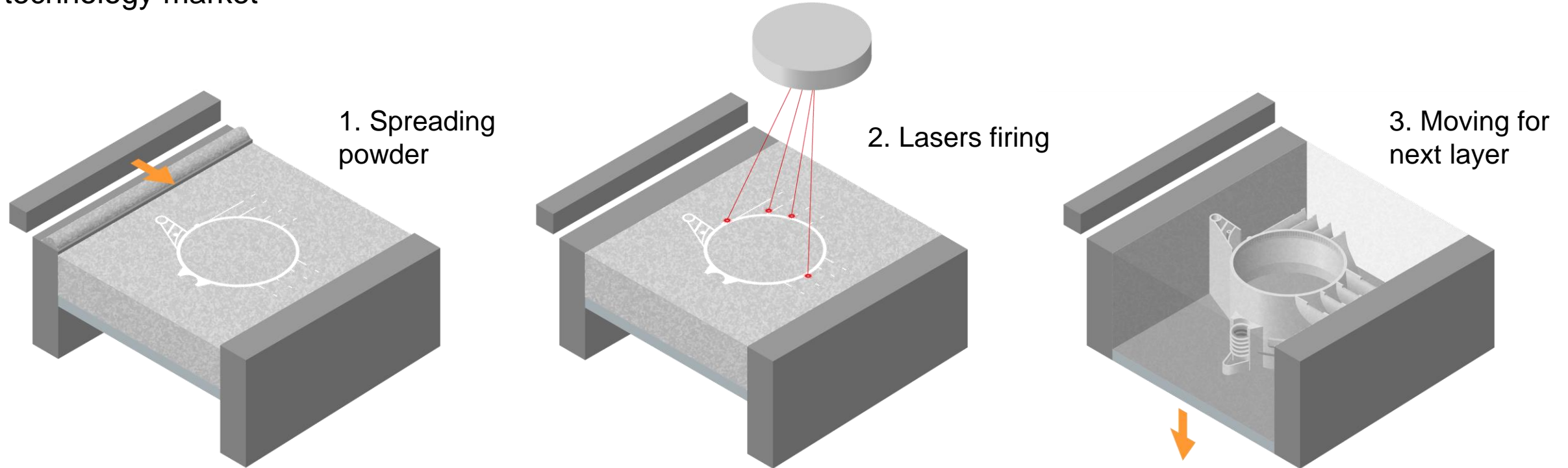

1. Wohlers Associates

AM structural market drivers

Megatrends that underpin sustained demand growth



Well positioned in market growing at c. 20% p.a.

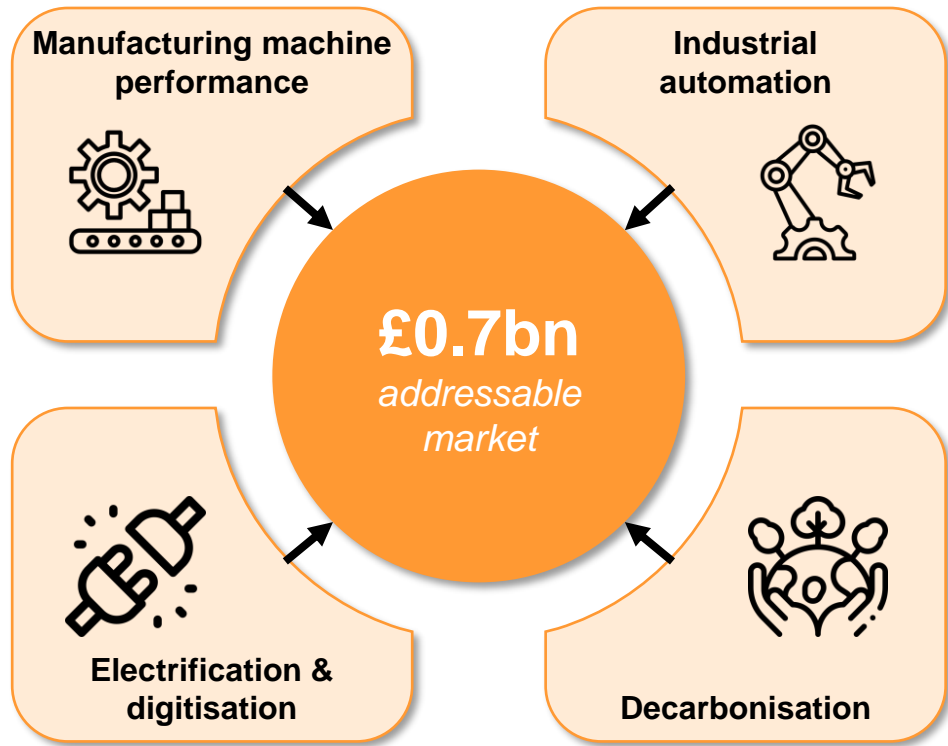

Driver	Influence	AM benefits
	Major influence	<ul style="list-style-type: none"> Product detail & complexity Material properties
	Major influence	<ul style="list-style-type: none"> AM process automation Simplified production routing
	Major influence	<ul style="list-style-type: none"> Rapid design realisation Real-time process monitoring
	Major influence	<ul style="list-style-type: none"> Low material & energy use Low carbon footprint products

Our mission

Accelerate the adoption of metal additive manufacturing as a viable high volume production process

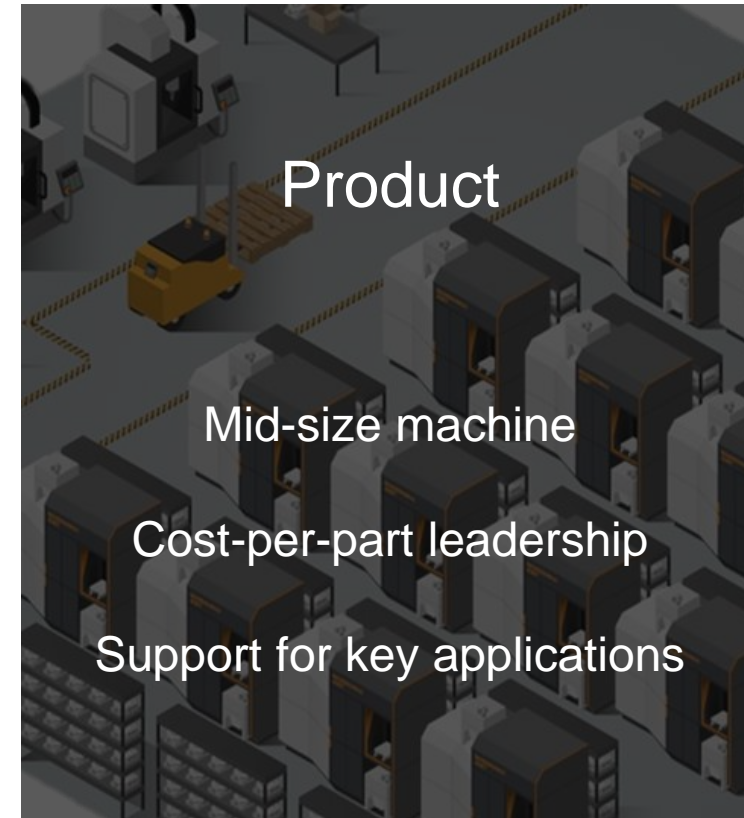
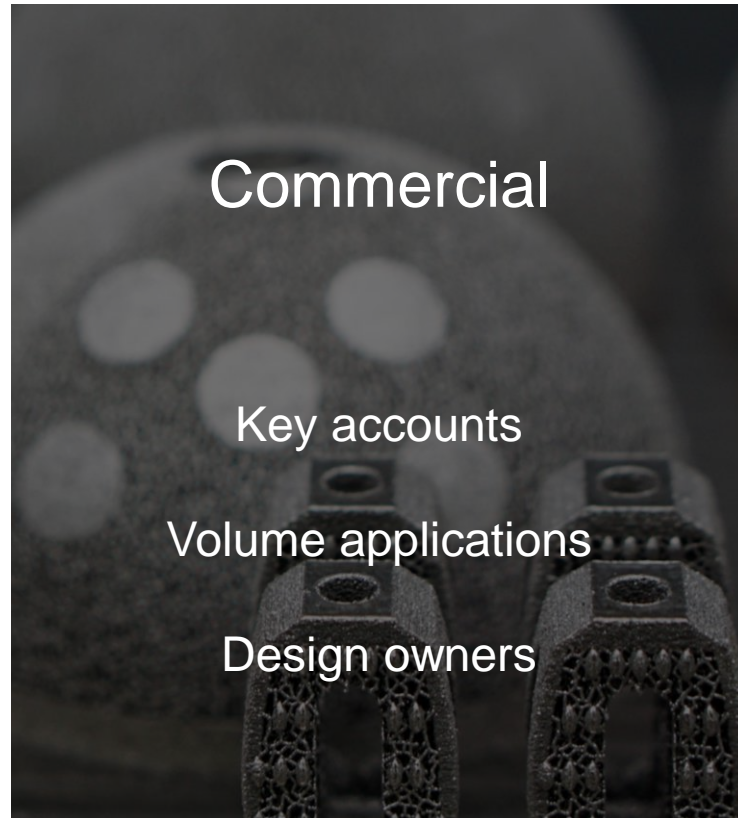

Growth constraints

What factors are limiting wider AM adoption?

Cost-effectiveness

Relatively high cost-per-part remains the biggest barrier to widespread AM adoption.

Consistency

As our key accounts look to qualify and scale their products into volume manufacture, consistency is critical, both in terms of machine-machine and performance over time.

Connectivity

Realising the full value of AM requires making the most of software, from CAD to QA. Therefore, it's vital we integrate into that digital process.

Culture

AM is a relatively immature manufacturing process, know-how and adapting to this capability is a significant obstacle to adoption.

Cost-effectiveness

RenAM 500 Ultra – a new level of AM productivity



RenAM 500 series, including Flex (L) and Ultra (R) variants

- Integration of TEMPUS technology boosts productivity by up to 100%
- All the benefit of RenAM 500's class-leading part quality, footprint and recirculation system.
- Empowers expert AM users with meltpool process monitoring

“Completing more builds in a day without compromising on quality means we can service our customers more efficiently and effectively, and creates capacity for growth.”
MADIT, Spain



Aluminium alloy fluid transfer component of car refrigeration system
Credit: MADIT

	Typical single-laser system	RenAM 500Q Ultra
Build time (hh:mm)	30:40	7:04

Consistency

Optical System Verification – process foundation for AM

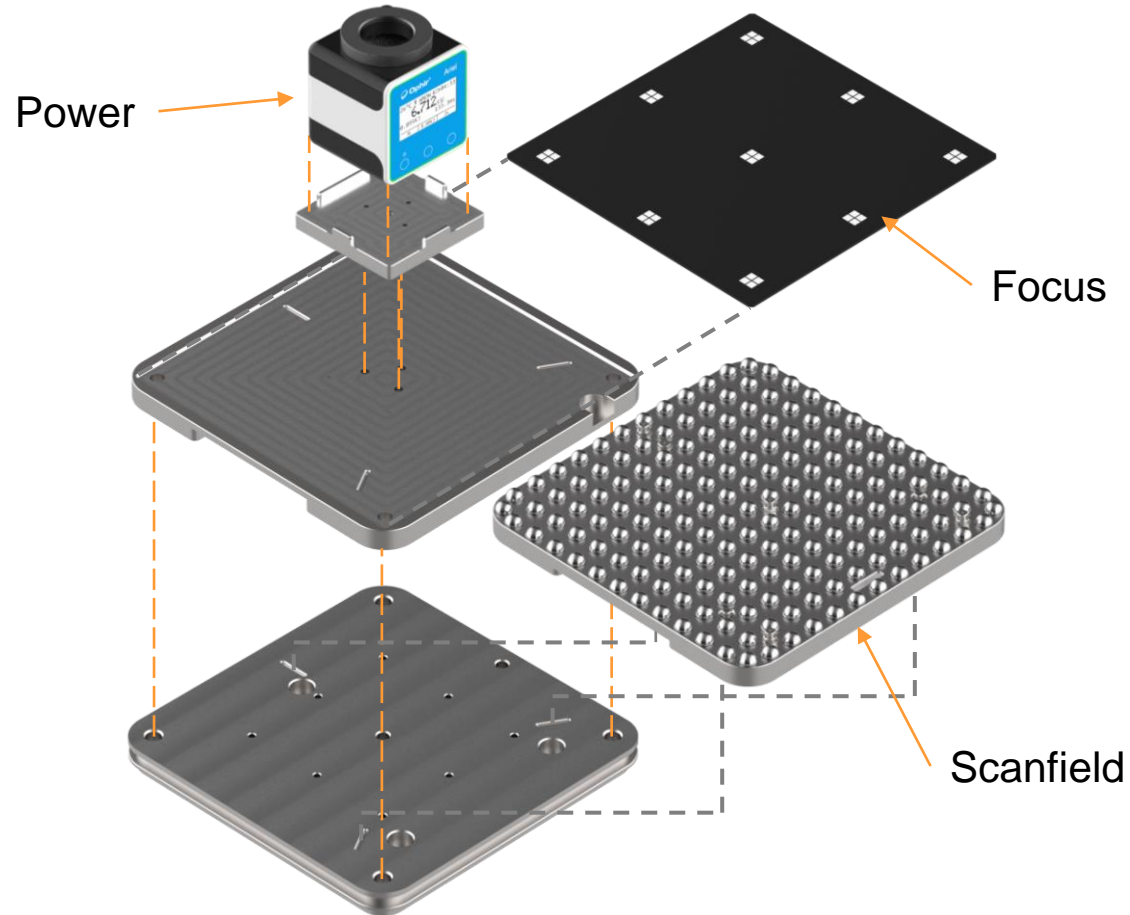

- Ensuring process stability is vital for scale adoption of AM
- Accessory for customers to verify the performance of all four lasers and optical control system to suit their process controls and part criticality.
- Traceable artefacts to international standards and calibrated measurement devices.



Connectivity

Software to optimise AM process performance

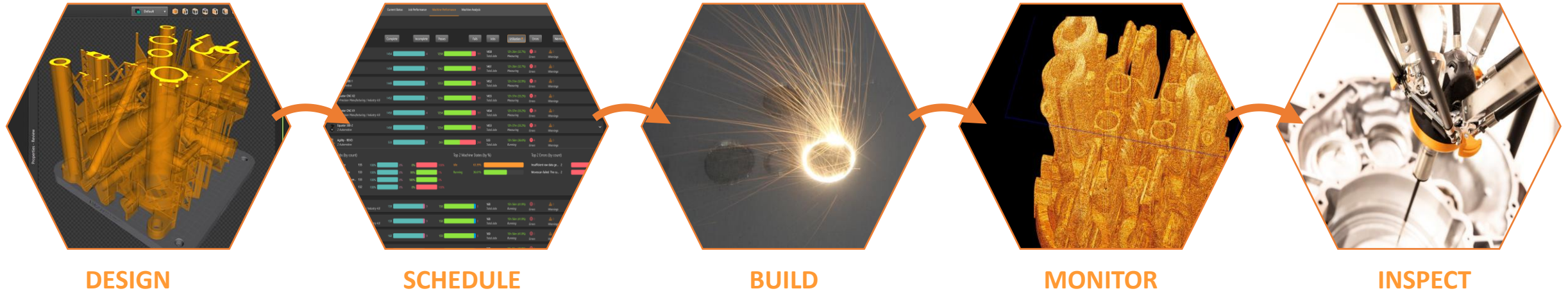

Maximising AM value requires leveraging the fully digital workflow from end-to-end.

In-house software integrates closely with hardware innovations while providing application interfaces (APIs) to connect to third party software tools.

QuantAM:

Build file generation API and application. Range of integration partners including end-users. Focus on explicit build activity definition.

Renishaw Central:

Production monitoring across Renishaw product lines – includes data API

InfiniAM suite:

Informative process control – meltpool visualisation and plugin (API) data access

Culture

Overcoming cultural inertia is critical to unlock AM benefits

Processes

Company-wide systems favour existing manufacturing techniques; typical stock sizes, material types, software and finishing methods are suboptimal for AM.

Portfolio

Product ranges have been designed for conventional manufacturing, identifying AM suitable components requires investment and know-how.

Personnel

Decades of embedded knowledge of design for traditional manufacturing offers a challenging baseline for DfAM.

Our AM4All internal program continues to address these challenges and identify the opportunities for AM across Renishaw.

Tooling for
Renishaw
machine tool
product line



Current generation platform

Supporting customers on their journey to volume AM production



LAB:
Material prove out



PRE-PRODUCTION:
Part prove out



FACTORY:
Volume production

Next generation platform

Step change in AM part costs



The AM process remains the biggest contributor to total part costs, and the biggest barrier to widespread AM adoption.

Productivity

Leverages a multiplier effect for reducing cost per part:

managed system cost, increased laser productivity and reduced turnaround through automation

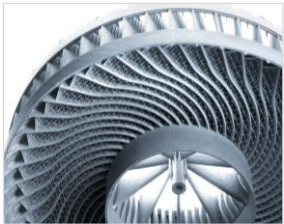
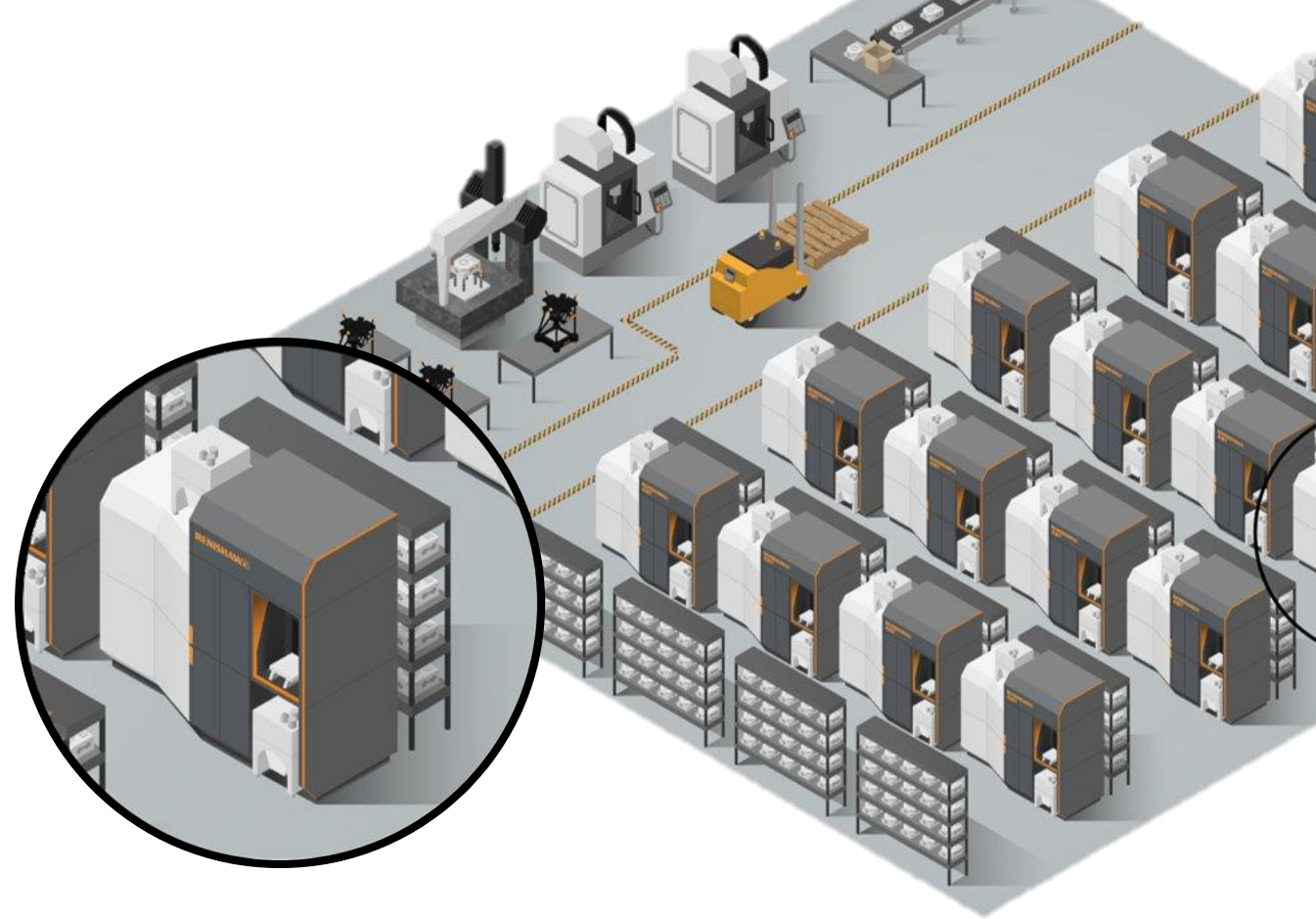

Retaining industry leading part properties enable lighter weight, lower material cost components with fully inert processing

Precision



Support for scale deployment with enhanced connectivity and serviceability, with modular architecture

Practicality

Q&A

Louise Callanan

Director of Additive Manufacturing

Matt Parkes

AM Strategic Development Manager



Extending into new markets

Blake Kendrick

Industrial Automation

Global Sales & Marketing Manager



Strategy to drive consistent outperformance

Three areas of strategic focus to combat competition & grow our market share

Strategy driving consistent outperformance

Growing in existing markets



Increase revenue per machine tool



Win new machine builder customers



Build systems sales



Expand software business



Smart factory solutions

Extending into new markets



Diversify into close-adjacent markets

Strategic priority

Automation – a system-wide view

Process automation

- Replacing manual activities with technology to set up, control and validate processes consistently
- Introduce intelligence and decision making into unmanned factories

Digitalisation

- Automatic collection of data for real time processing, analysis and process adjustment
- Real-life data feeding into digital twins, AI and machine learning tools

Factory automation

- Devices for work handling, moving material and transportation
- Space efficient, dextrous motion platforms for processing operations
- Easier integration and application for wider adoption

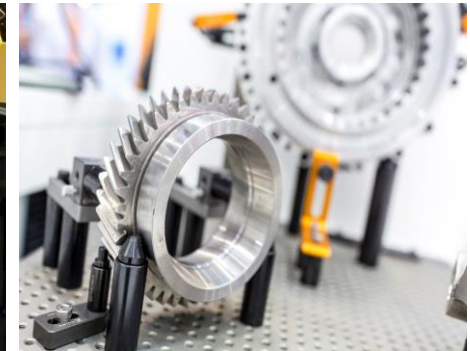

Why target Industrial Automation?

An exciting, untapped, neighbouring market

1
2
3
4
5

A large, established, quickly growing market

Closely adjacent to our core business

Setup of industrial automation is very manual and time consuming, and difficult to maintain

Analogous to CNC machine tool market 20-30 years ago

Able to bring Renishaw's proven technology and metrology expertise to a large untapped marketplace



Industrial Automation

A trajectory of growth

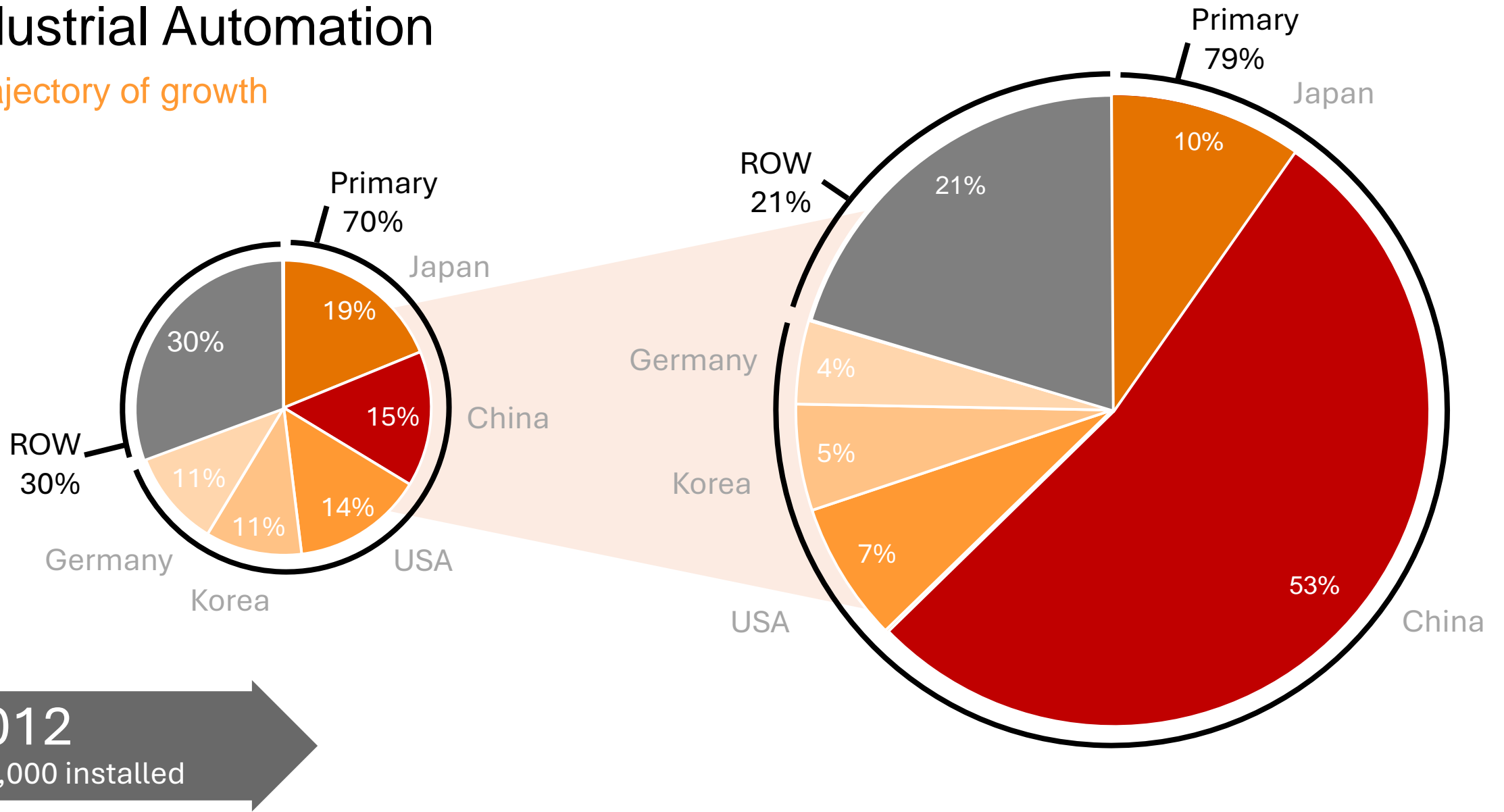

2012

159,000 installed

Typical automation setups

Industrial cells and robots

Automation Cell

- Industrial 6-axis robot
- Delta robot
- SCARA robot
- Gantry robot
- Robot controllers
- Part handling
- Rails and rotary tables
- Guarding and safety systems

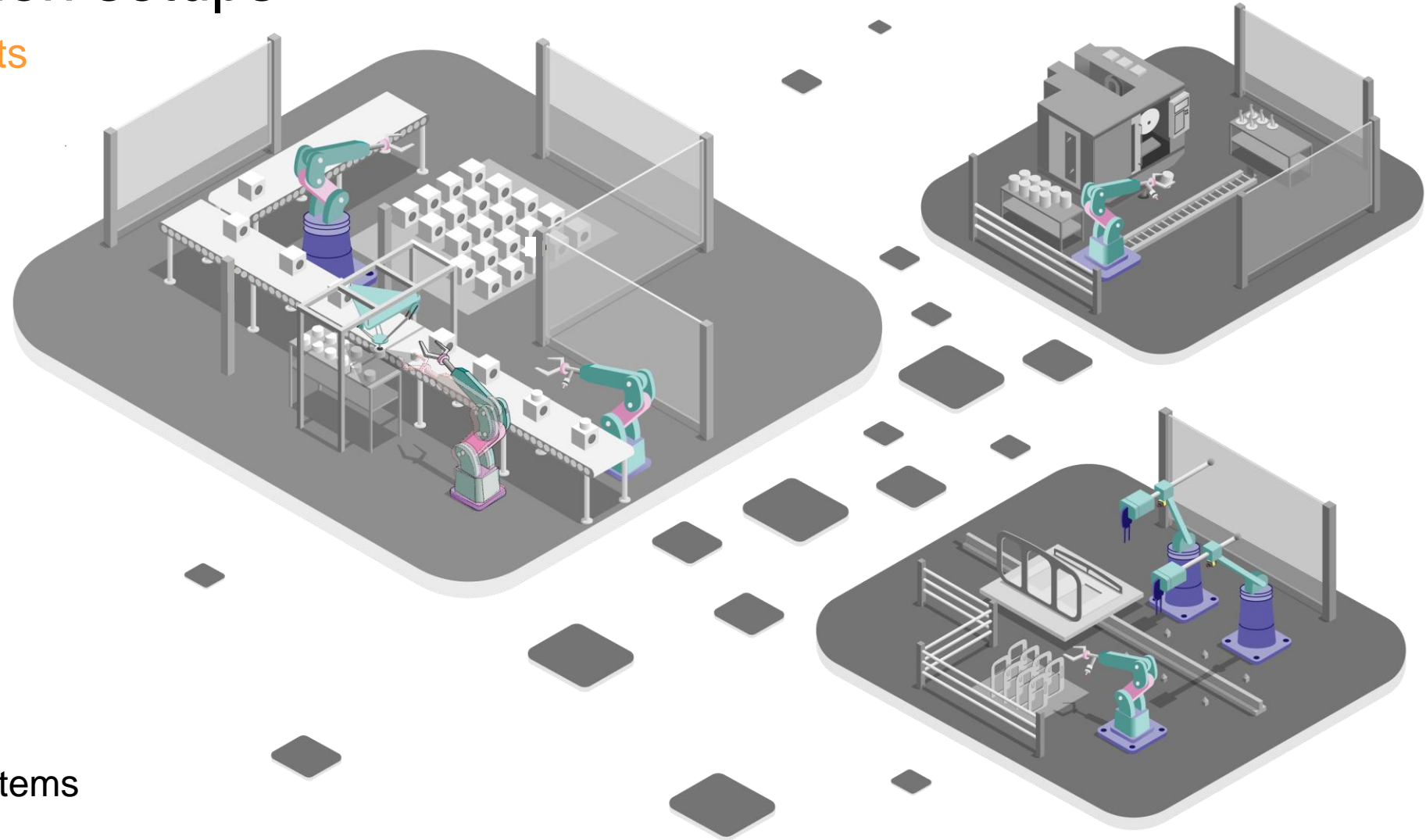



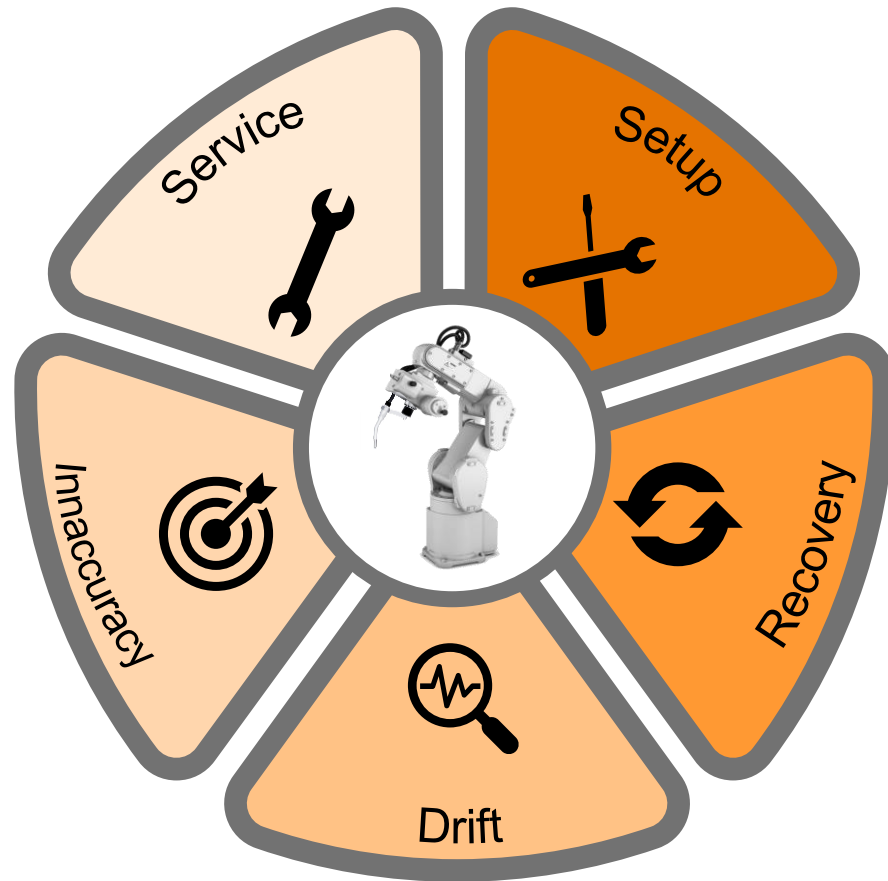

Major challenges

Issues slowing industrial automation adoption



Current challenges

-  **Setup** Manual commissioning and verification reliant on user's skill
-  **Recovery** Excessive time wasted on getting a cell working again after it has failed
-  **Drift** No means of recording the change in performance of a cell over time
-  **Inaccuracy** Highly repeatable, but inaccurate devices, which have the potential to become more accurate
-  **Service** Manual, inconsistent and subjective approach (visual, audible, smell-based, resistance-based)



Renishaw RCS products

Directly addressing the challenges of Industrial Automation

RCS product process flow

Practical solutions for major challenges in robotics

Setup

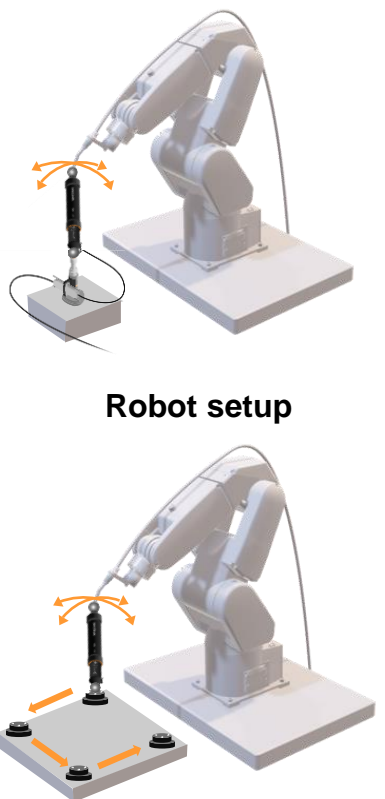

Robot setup

Part setup

The 'Setup' column contains two illustrations. The top one, 'Robot setup', shows a white robotic arm with orange arrows indicating its range of motion. The bottom one, 'Part setup', shows the same arm with a grey part on a table and orange arrows indicating the part's position and movement.

Diagnostics



Ongoing checks

Performance verification

The 'Diagnostics' column contains two illustrations. The top one, 'Ongoing checks', shows a white robotic arm with orange arrows indicating its range of motion. The bottom one, 'Performance verification', shows the same arm with orange arrows indicating its range of motion and a circular arrow indicating a cycle or loop.

Process Improvement

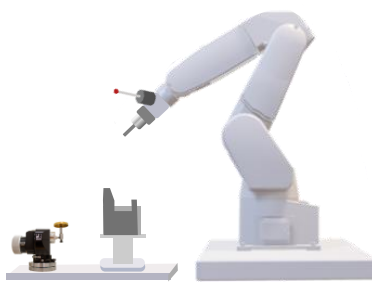

Probing datuming

The 'Process Improvement' column contains one illustration, 'Probing datuming', showing a white robotic arm with a probe tip touching a grey part on a table.

Recovery



Crash recovery

The 'Recovery' column contains one illustration, 'Crash recovery', showing a white robotic arm with a red exclamation mark and a circular arrow icon, indicating a recovery process.

Service

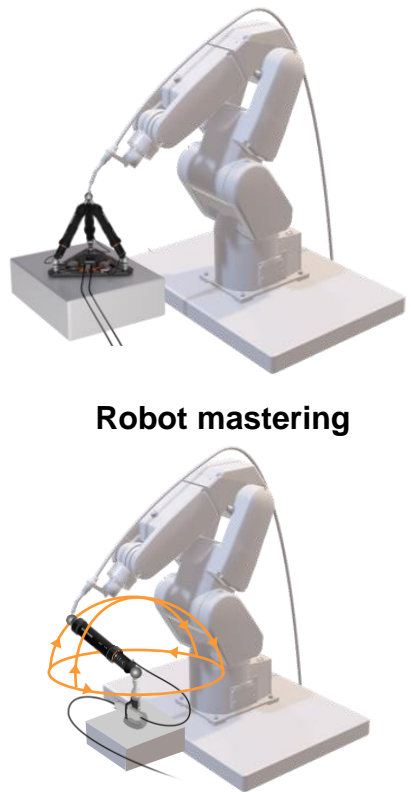

Robot mastering

Verification checks

The 'Service' column contains two illustrations. The top one, 'Robot mastering', shows a white robotic arm with a grey part on a table. The bottom one, 'Verification checks', shows the same arm with orange arrows indicating its range of motion.



RCS T-90, RCS L-90 and RCS P-series

The bottom section of the slide features a collection of images showing various robotic arms and components, including a black robotic arm, a white robotic arm, and several motor and sensor units.

Automating automation setup

Eliminating the manual bottlenecks in commissioning and diagnostics

Legacy pin-to-pin robot commissioning



Renishaw automated approach

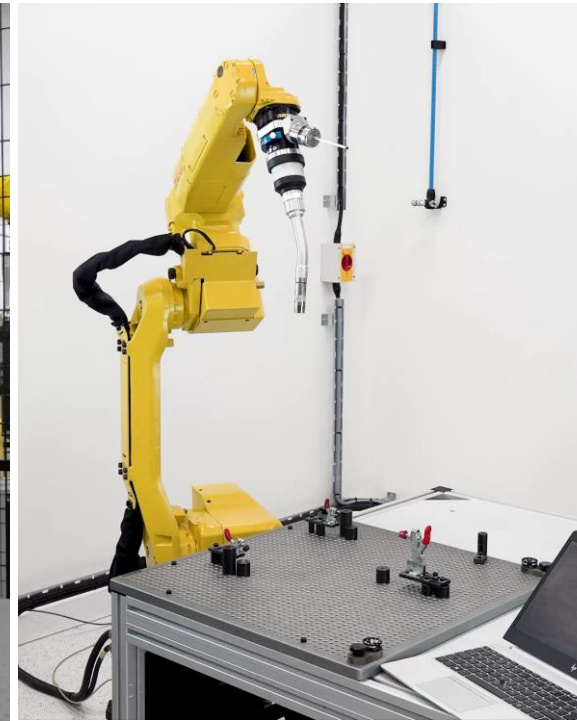

Case: US-based Integrator

Need:

- Running Robot Diagnostics
- Easily setting Tool Centre Point (TCP)

“ At One Off Robotics, precise calibration is crucial to our business, which is why we were delighted to use this Renishaw technology with our robot setup ”

Improving robot performance

Mastering robot axes and providing robot consistency

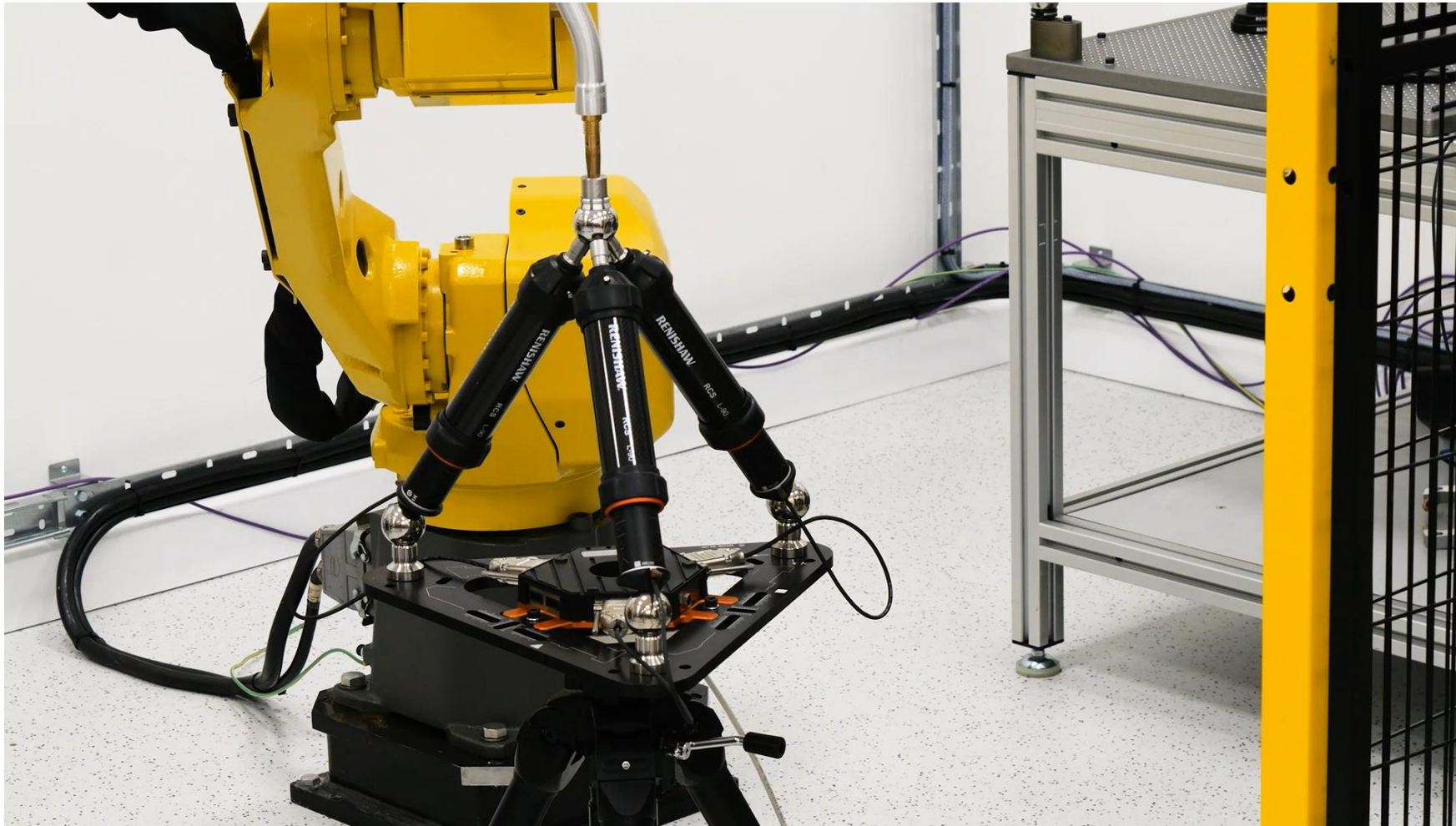

Case: Major Aerospace Company A

Need:

- Mastering of robot axes
- Consistency of worldwide cell deployment

Outcome:

- Global adoption of approach
- 12 worldwide facilities purchasing full kits, with more in coming months

Improving robot performance

Real world example

Region:
China

Customer:
System Refurbisher

Rationale:
Verification of
nearly-new robot by
a Refurbisher before
being supplied to an
end-user



Before

Polar plot of radius error

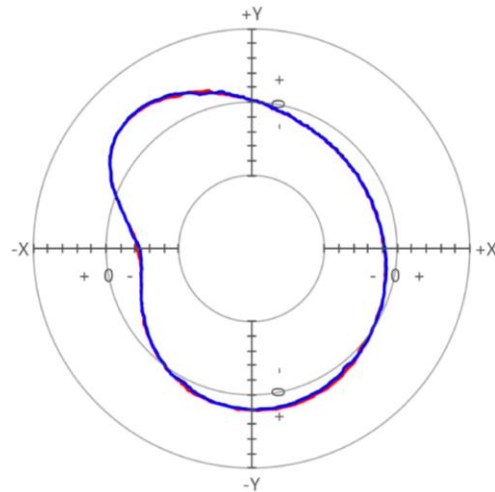

Form Error: 4.696 mm

— Counter-clockwise
— Clockwise

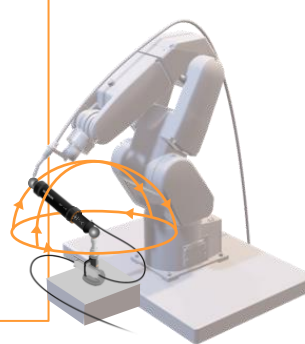

Overall Results

New Tool Frame

Index: 1 **Name:** Tool_1
X: -36.621 mm **Y:** -39.953 mm **Z:** 390.612 mm
Rx: -0.0000° **Ry:** -0.0000° **Rz:** -0.0000°

Absolute Calibration Error: 0.527 mm

Joint Offset Correction Pose

Joint 1: 0.0000° **Joint 2:** 0.2618° **Joint 3:** 0.0068°
Joint 4: 0.7713° **Joint 5:** 0.0187° **Joint 6:** 0.0000°

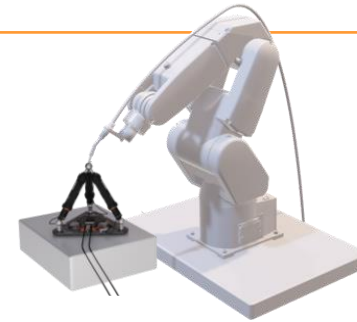

After

Polar plot of radius error

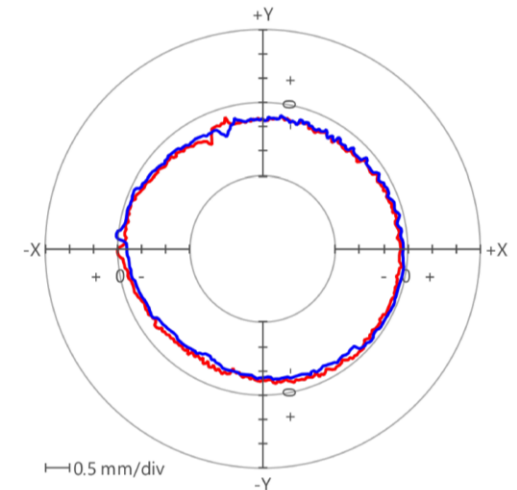

Form Error: 0.676 mm

— Counter-clockwise
— Clockwise

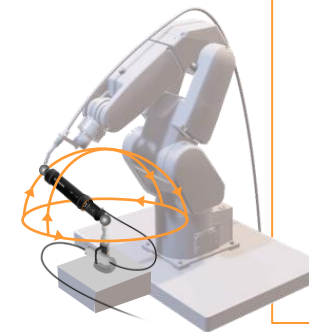

Automating cell recovery

Getting production up and running quickly with minimal intervention

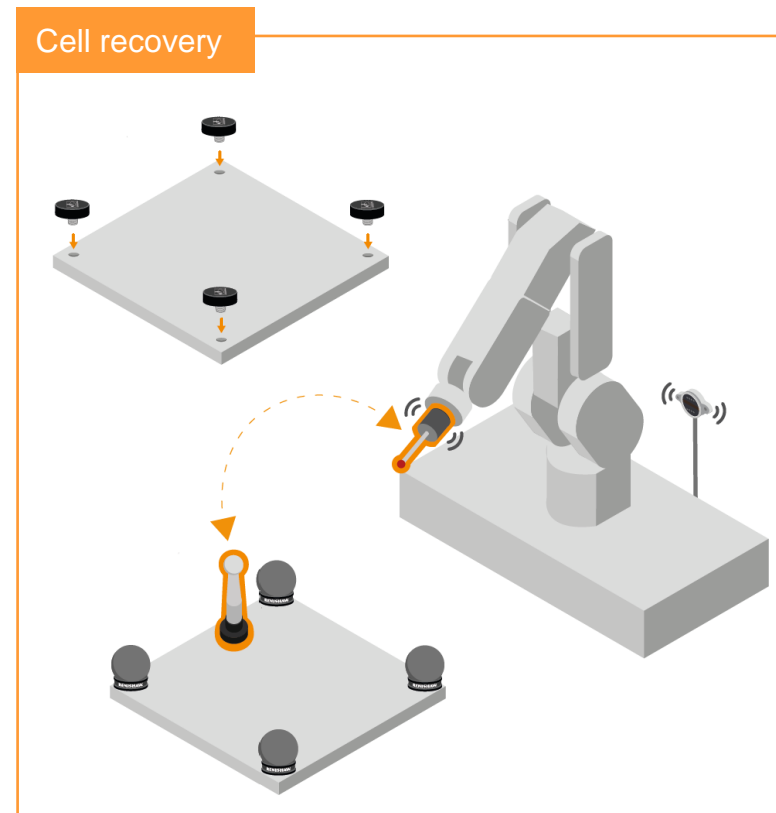
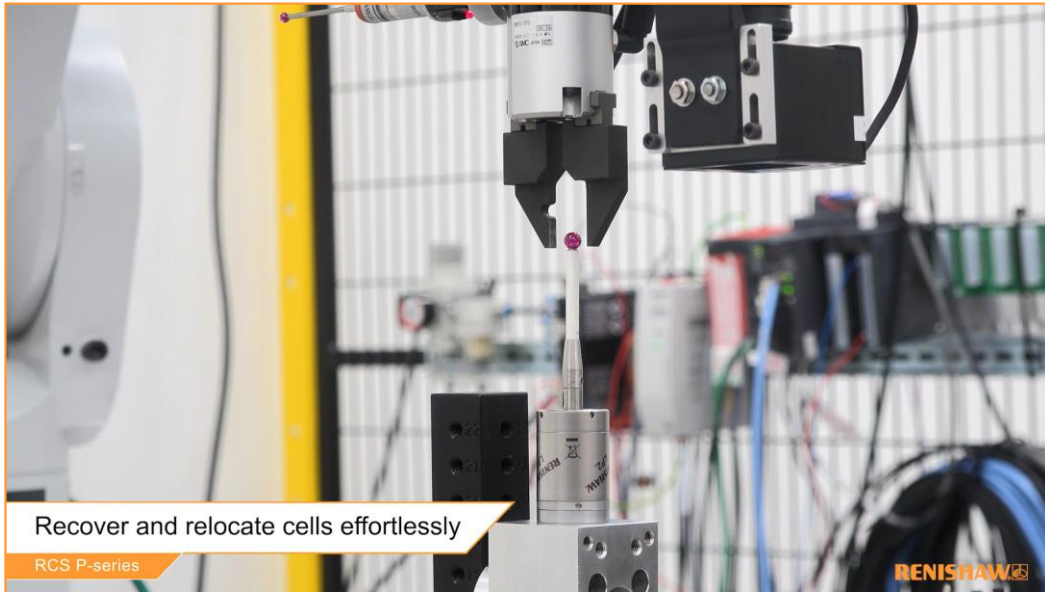

Case: Renishaw MSD

Need:

- Scaling existing automation cells
- Recovering quickly from issues without extensive engineering support

“ Internal use of RCS P-series probing has enabled rapid expansion and confidence in our automation plans ”

Increasing robot potential

Additional accuracy opening new applications



Case: Major Robot OEM

Need:

- Consistent method to set position and cutting angle of robot-based machining tools
- Quick check of tool lengths
- Locating different parts

Outcome:

- Showcase of Renishaw solution on the Fanuc Stand at Automatica 2024, Munich, Germany

The route to the market

Channel partner programme

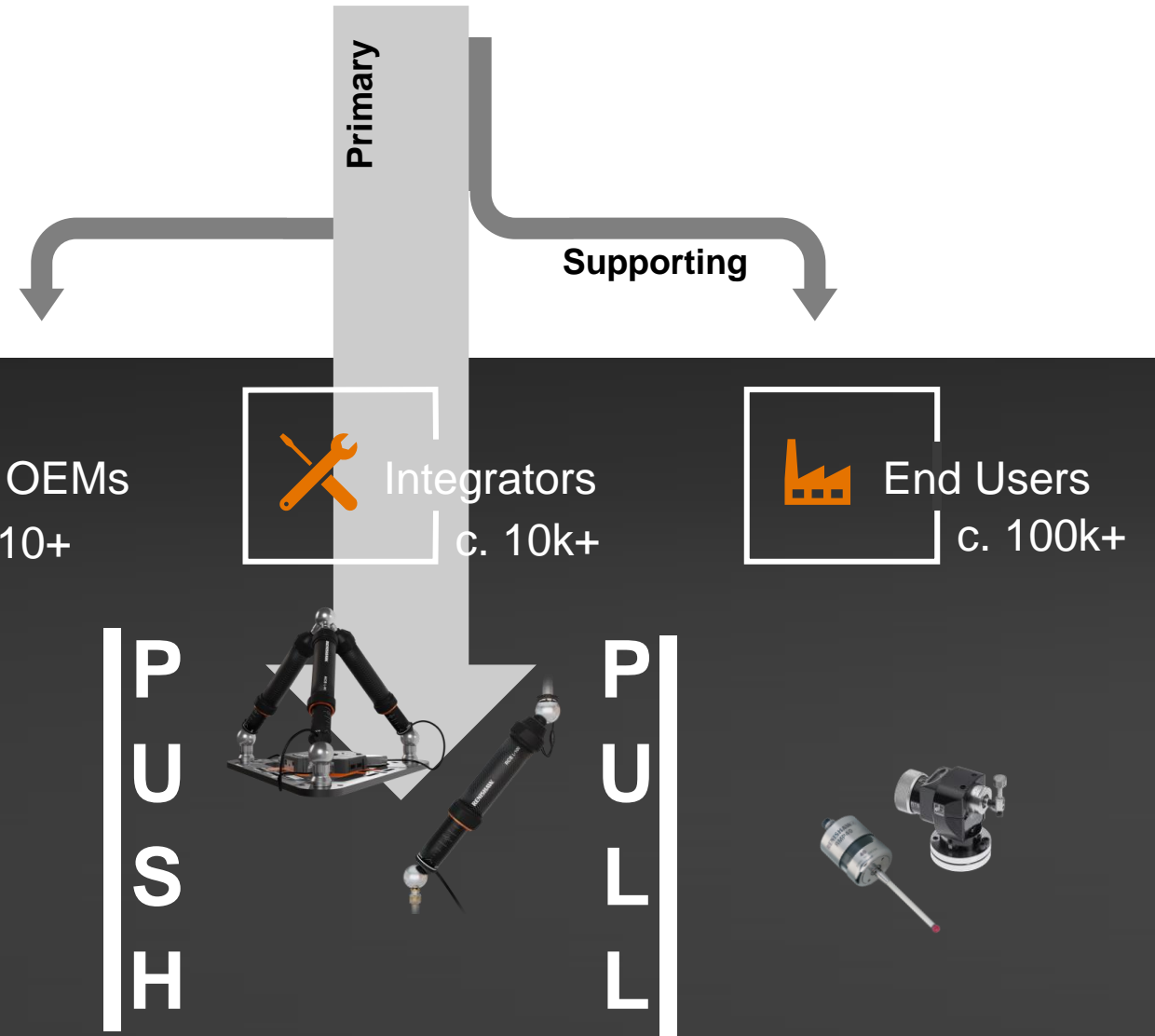

The route to the market

Channel partner programme



Robot OEMs
c. 10+



Integrators
c. 10k+



End Users
c. 100k+



P
U
S
H

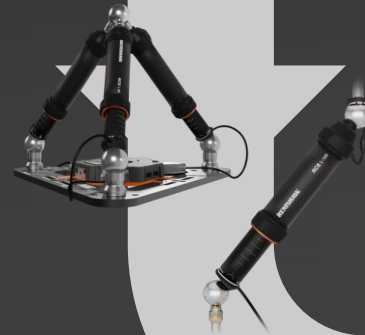

P
U
L
L

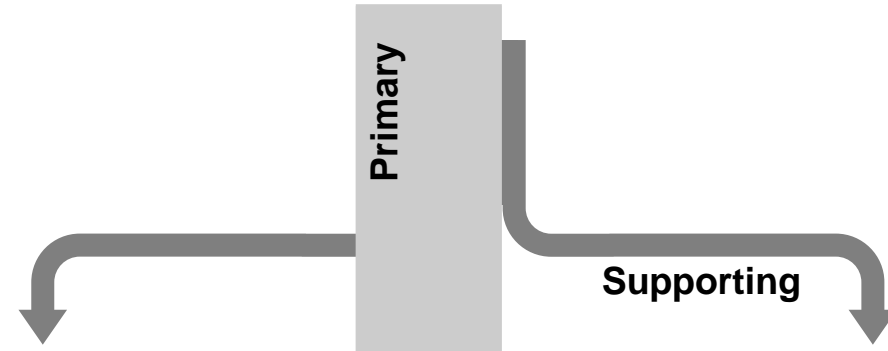

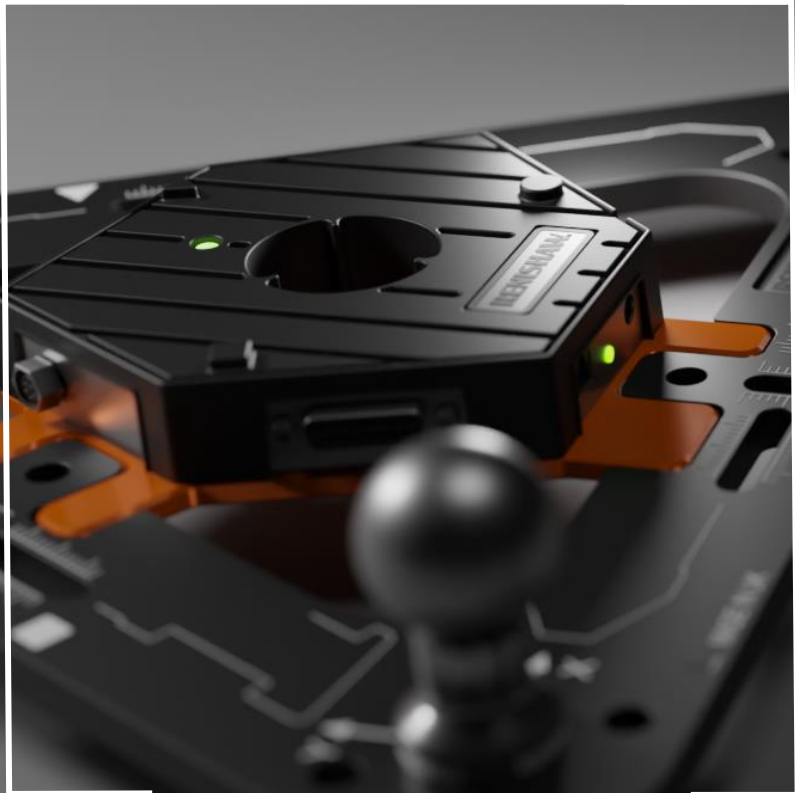

Any questions....

Extending into new markets
Spotlight on Industrial Automation

Blake Kendrick
IA Global Sales &
Marketing Manager



Manufacturing strategy

Gareth Hankins

Group Manufacturing Director



RENISHAW 
apply innovation™

Manufacturing – a key element of our outperformance strategy

Value creation model

Competitive position

Market segmentation

Market growth

Market share

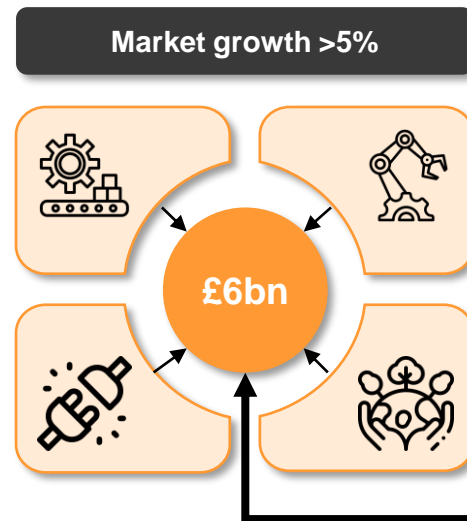

Outperformance

Existing markets

Tech value

New markets

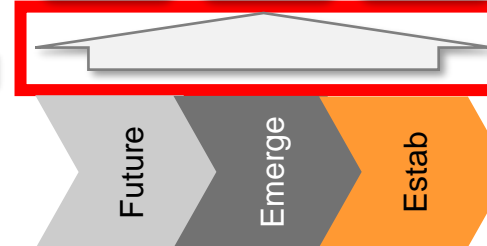

Strategy

Strategic priorities

Capital allocation

Portfolio growth

Manufacturing strategy topics

Strategy



- Global competitiveness
- Showcase & testbed for our products

Capabilities



- Volume, complexity & variety
- Footprint & key processes

Investment



- Capex & engineering
- Miskin expansion
- Sustainability

Supply chain

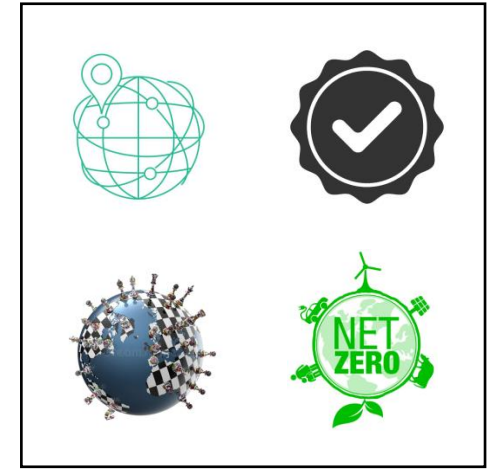

- Risk management, compliance & sustainability

Manufacturing strategy

Globally-competitive manufacturing:

- Perform all important manufacturing operations in our factories to give us control of costs, quality & delivery
- Use our own technologies to maximise precision & productivity
- Continuous process development & progressive process automation to maintain competitiveness
- Design for manufacturing / assembly / procurement (DFX) to enable rapid new product introduction



A vertically-integrated manufacturer

In-house manufacturing supports high gross margins

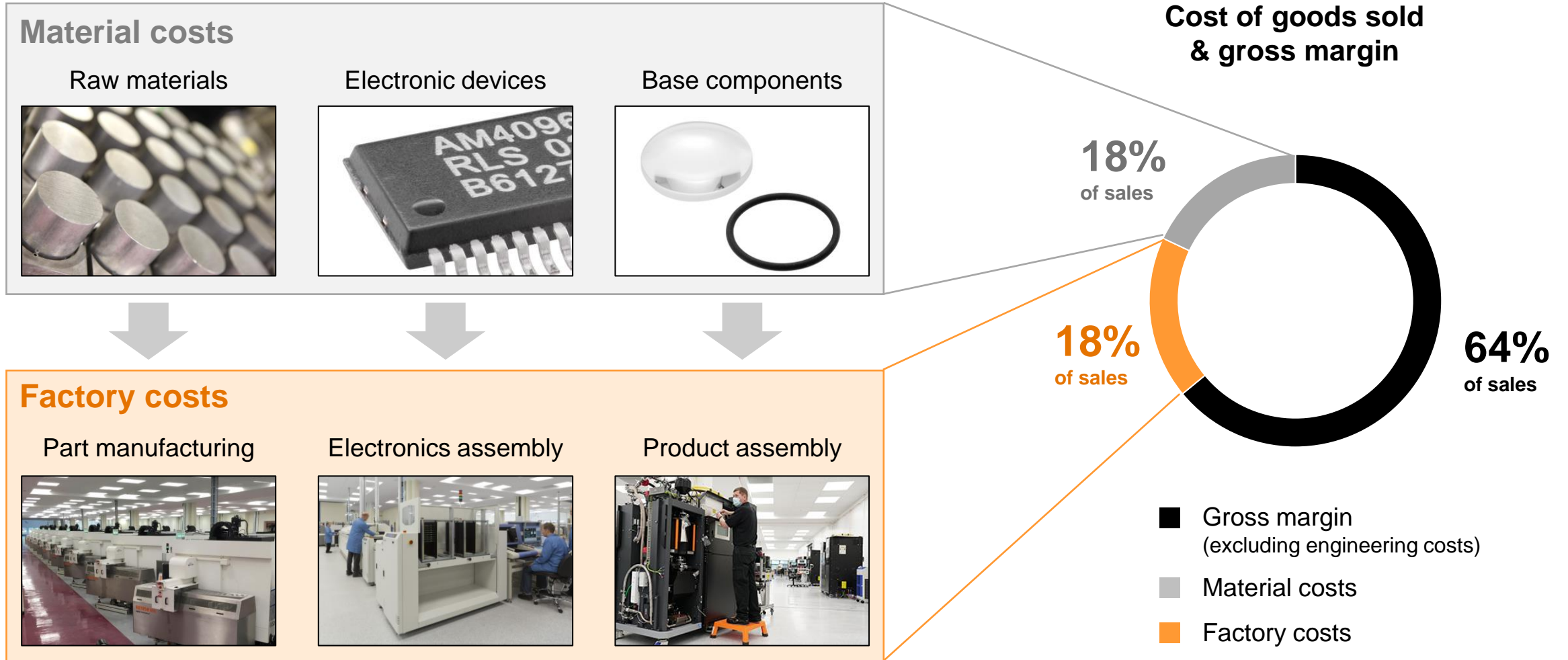

Our manufacturing challenge

Broad product range across a spectrum of production volume and product complexity



Styli



Position encoders



Metrology sensors



Calibration



Capital equipment



Volume

Very high

High

Medium

Low

Complexity

Low

Medium

High

Very high

Variety

50,000 components

+

40,000 sub-assemblies

+

60,000 products

Our manufacturing footprint

Critical functions distributed across multiple manufacturing sites

Gloucestershire



Stonehouse

- 9,000 sqm
- Machining
- Process finishing
- 200 staff



Woodchester

- 15,000 sqm
- Electronics assembly
- Product assembly
- 500 staff



New Mills

- 7,000 sqm
- New product introduction
- Spectroscopy assembly
- Additive manufacturing
- 150 staff

South Wales



Miskin

- 96,000 sqm, (52,000 sqm newly constructed)
- Machining
- Process finishing
- Electronics assembly
- Product assembly
- 650 staff



Overseas



Dublin, IRE

- 9,000 sqm
- Product assembly
- Neurological
- 200 staff



Pune, IND

- 15,000 sqm
- Product assembly
- 200 staff

Völklingen, DE

- Styli

Lyon, FR

- Neurosurgical robots

Component manufacturing

- 200 CNC machines across 2 sites
- 24x5 operation, plus weekend working
- > 1.5 million parts per month

Machining centres



Mill-turning centres



Sliding head lathes



Metal 3D printed galvo block



Showcasing our manufacturing technologies



Practicing what we preach

- Our machining facilities are showcases for what can be achieved by intelligent application of metrology, position measurement and design for manufacture
- Integrated process control and in-house automation enable 24-hour unattended production of high-variety / medium-volume components
 - Up to 140 value-added hours per week
 - < 0.5% machining scrap
 - 1 operator running 8 machines
 - 200 CNC machines across 2 main production sites
 - 24x5 operation, plus weekend working
 - Typically producing 1.5 million parts/month

Green lights on a row of automated machining centres. Low manning levels enable globally-competitive costs to be achieved in UK factories

DFX is the foundation of world-class manufacturing

A close link between design and manufacturing

Design for manufacture / assembly etc (DFX)

- Re-use proven, repeatable processes
- Builds deep process expertise, enabling automation & improvement
- Standardised equipment = flexibility

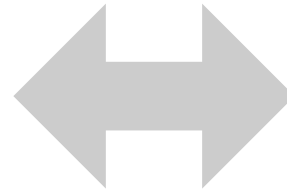

New product introduction (NPI)

- Partnership between Design and Manufacturing
- DFX enables faster process development & smoother production scale-up
- Dedicated new product introduction (NPI) facility

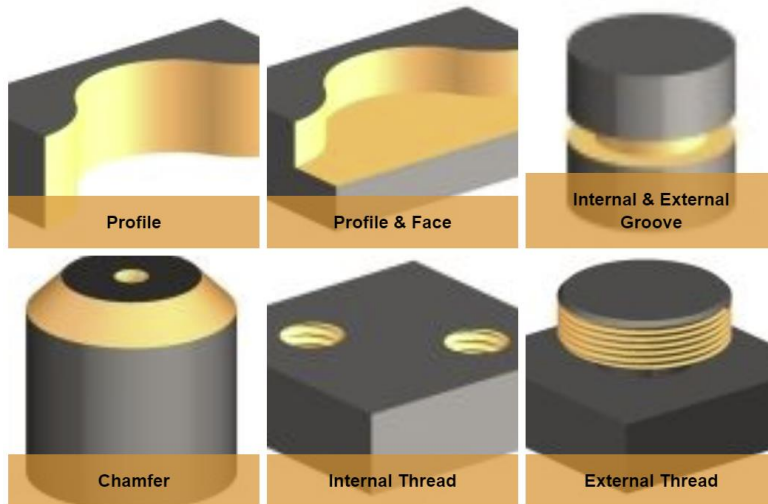

DFX
guidebook

NPI facility
at New Mills



Testbed for new products

Our most demanding customer is ourselves

Our factories are a rich source of insight into real-world manufacturing problems

First to evaluate new manufacturing technologies

Case study:

Renishaw CENTRAL smart data platform deployed across multiple manufacturing sites

- Powerful insights into patterns & trends
- Identified key sources of unplanned stoppages & opportunities to reduce set-up times to boost productivity



Process finishing

- Anodising plants on 2 sites
- Aqua-blasting, auto-deburring, hardening & laser engraving

Anodising



Deburring



Laser engraving

Electronics assembly

- 4 electronics production lines across 2 sites
- New product introduction line for rapid prototypes
- Automated flow lines & de-panelling
- Wire bonding of ICs and strain gauges
- Functional & in-circuit test



Electronics assembly at Miskin

PCB inspection at Woodchester

ATOM miniature encoder PCB



Product assembly

- Wide range of product assembly challenges
- Cellular assembly of low- and medium-volume products, with extensive use of step-locked jigs
- Increasing automation of high-volume operations & position encoders assembly using flow-line principles
- Developing dual site assembly capability for key products



Robotic automated assembly

Assembly of
AM machines



Cellular small product assembly

Investment in manufacturing

Investment in FY23 and FY24 to boost capacity, sustainability & productivity

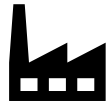

Capex

- Miskin expansion
- Machine tools
- Electronic assembly equipment
- Robotics & automation
- PV capacity, HVAC & insulation

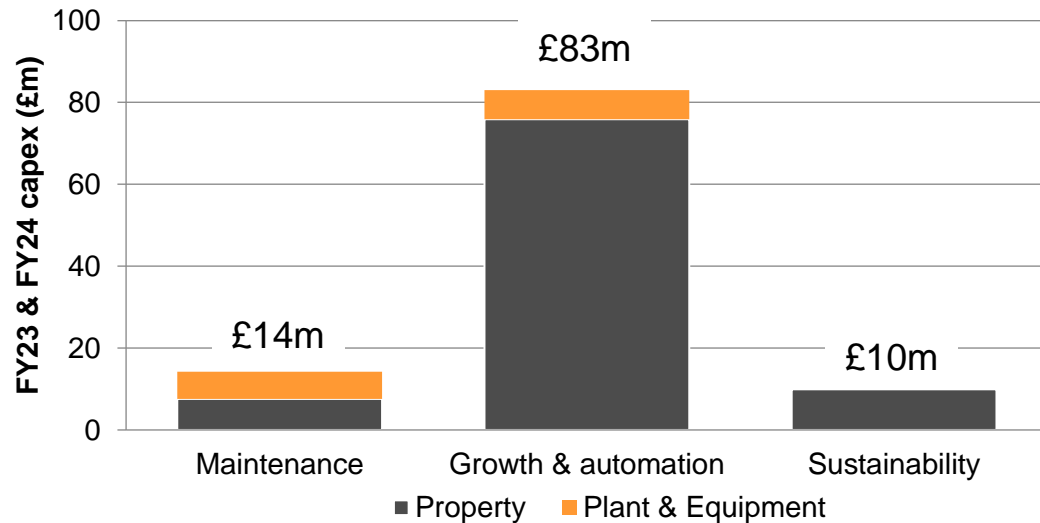

Engineering

- 200 manufacturing engineers
- New production processes
- Assembly process automation
- Warehouse & logistics automation

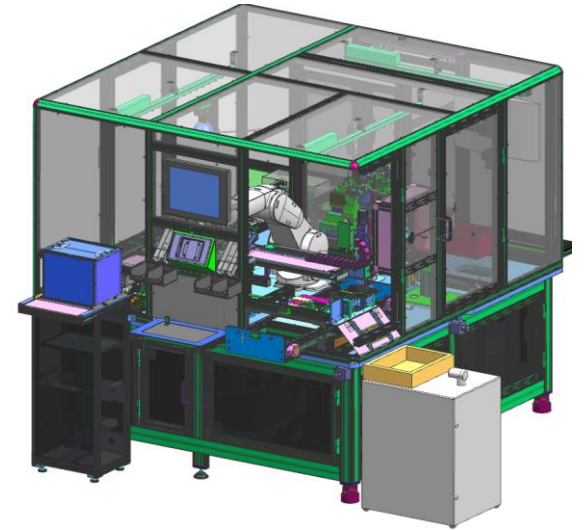

Encoder assembly cell



Gluebot



Robot metrology

Miskin expansion

Room to grow over the next 5 years

Additional capacity

- 193 acres site acquired in 2011
- Halls 1 & 2: 44,000 sqm now full
- Halls 3 & 4: 52,000 sqm additional space
- Occupation of Hall 3 in progress – assembly of large products (Agility CMMs, AM machines, FORTiS enclosed encoders)
- Hall 4 ‘mothballed’ – commission when needed for additional product assembly capacity

Sustainability

- Net Zero buildings
- 3.7 MW of PV self-generation
- Sustainability improvements to existing halls



Reducing our carbon footprint

An ongoing journey towards greater energy efficiency

- 88% reduction in statutory emissions per £m revenue since 2010
- Steady improvement in energy efficiency (MWh / £m) through investment in facilities and equipment
- Increasing use of renewable energy sources to reduce carbon footprint
- Rising self-generation from solar across our property portfolio – new arrays at Miskin & Brazil connected in FY24

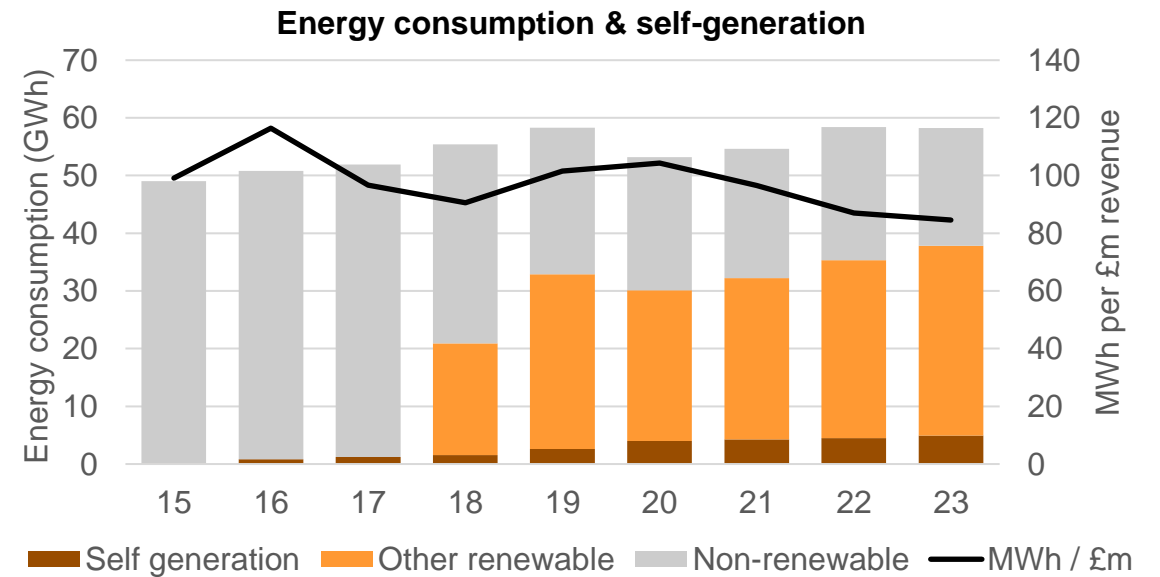
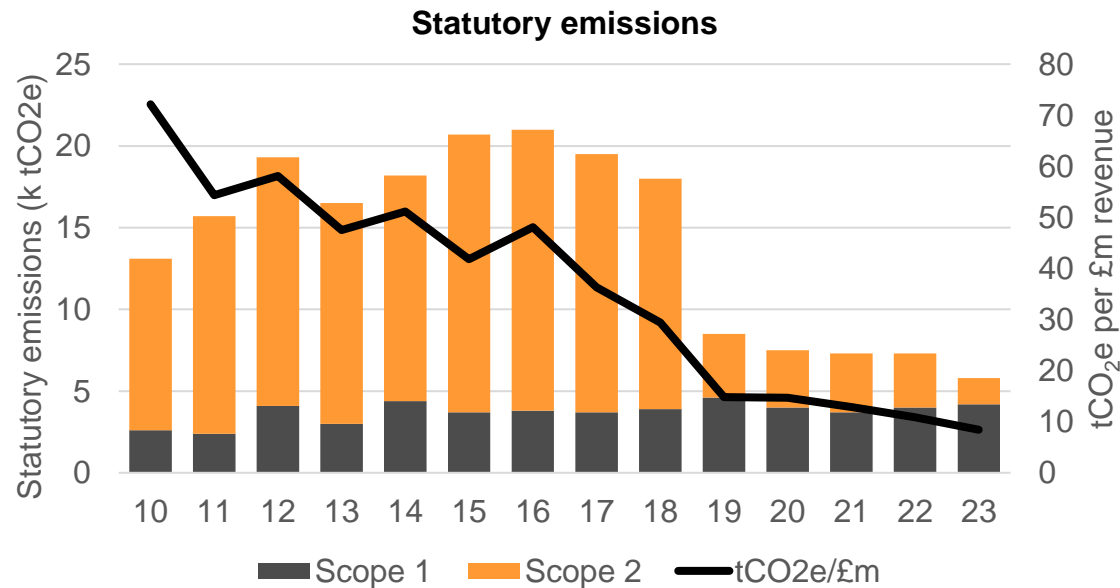

Supply chain

Risk management, compliance & sustainability



Q&A

Gareth Hankins

Group Manufacturing Director



Growth investment & driving returns

Marc Saunders

**Director of Group Strategic
Development**



Organic growth investment & driving returns

Value creation model

Competitive position

Market segmentation

Market growth

Market share

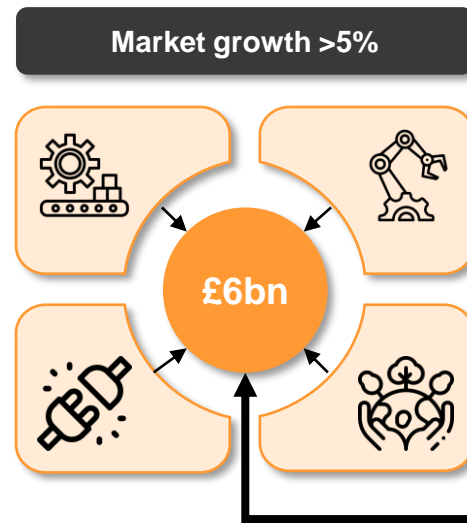

Outperformance

Existing markets

Tech value

New markets

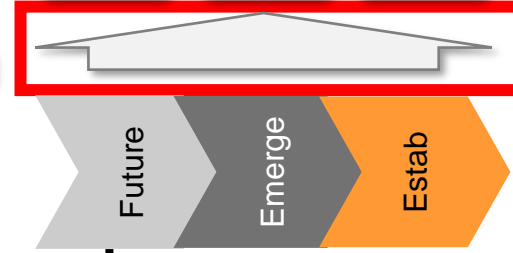

Strategy

Strategic priorities

Capital allocation

Portfolio growth

Created new market
Entered existing market

Growth through continuous innovation

50-year track record of growth and portfolio expansion built on innovative solutions

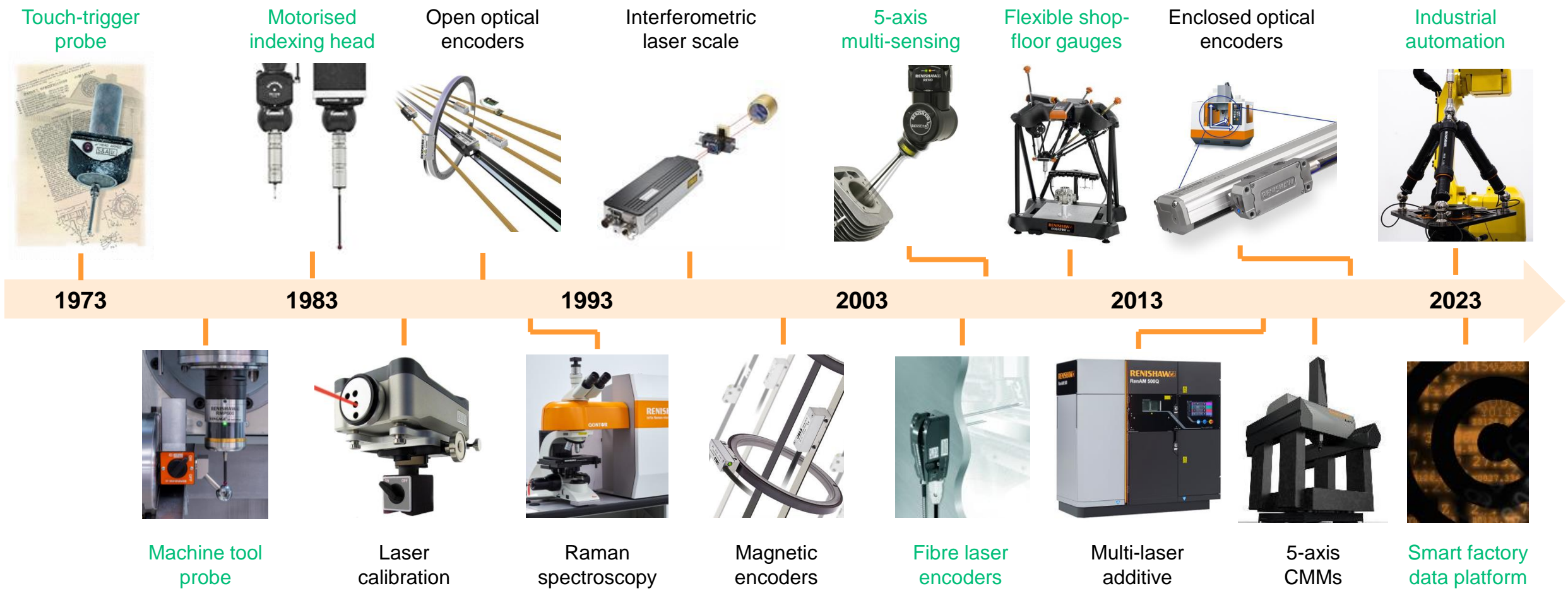

Growth investment topics

Capital allocation for through-cycle organic growth



Growth investment



Engineering

Maintain, upgrade & new products



Sales & marketing growth

Expand sales teams & routes to market



Capital expenditure

Grow our infrastructure & intellectual property

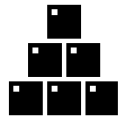

Working capital

Inventory & trading capital to support growth



Value creation & return on investment



Gross margin

Margin drivers & future trends



Return on invested capital

Robust balance sheet & solid returns

Engineering

Differentiated products enabling sustainable operating margins

Engineering investment:

- Novel solutions to solve customer problems
- Strengthen & expand our product ranges
- Intellectual property to enable high gross margins
- Efficient manufacturing processes



Innovation supports long-term growth & margins:



Precision

1800 patents



Productivity

350 patent families



Practicality

Gross engineering spend & headcount

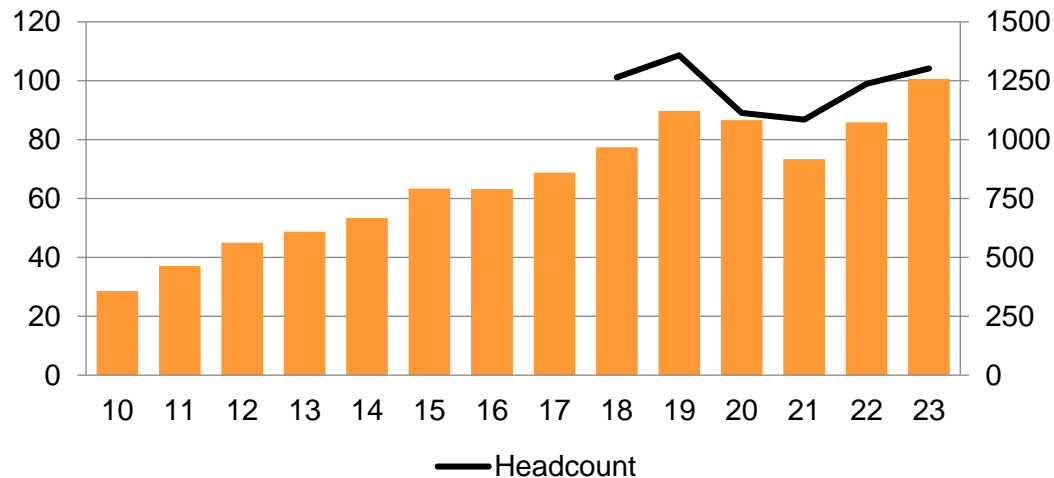

Engineering spend as % of revenues

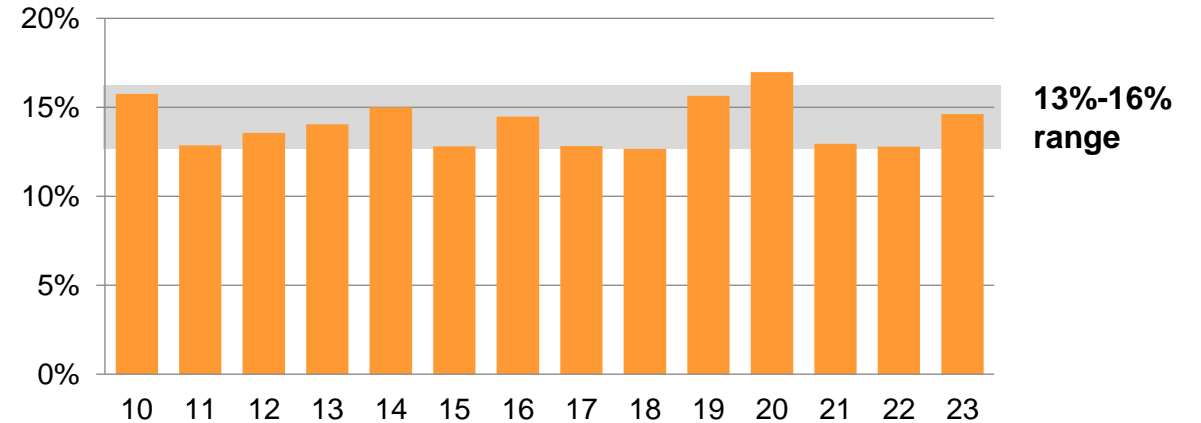



Engineering organisation

Inter-connected functions working together to develop & commercialise new products

Business function



Activities

- New product development
- New product introduction
- Product roadmap
- Technology research
- Current products
- IP generation

- Market intelligence
- New product launch
- New business development
- Application engineering

- Manufacturing engineering for new products
- Process improvement (automation, cost & quality)

- India software team
- Electronics design
- Laboratory services
- Component engineering
- Patents

Engineering headcount

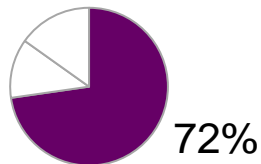

12%



15%





Engineering investment returns

A range of engineering activities to protect, enhance and diversify our product ranges

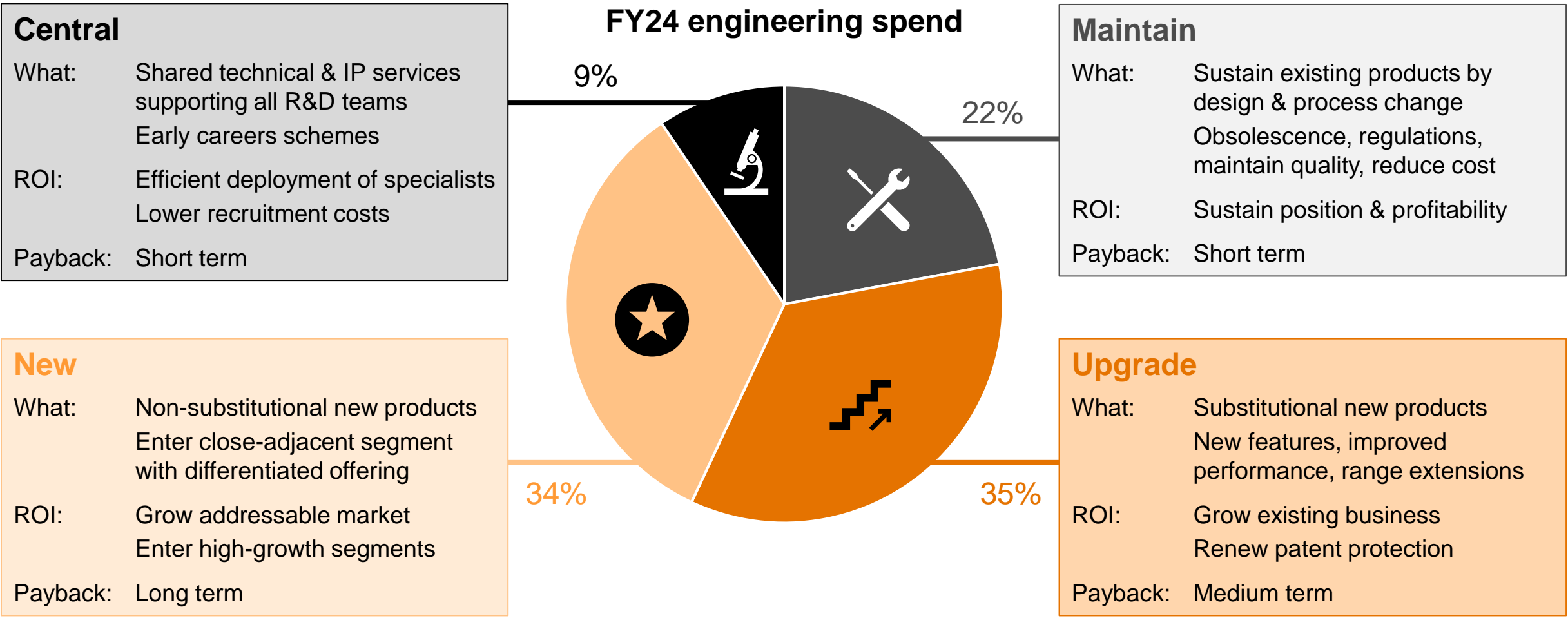



Portfolio development

Investing in established, emerging and future businesses to grow our portfolio

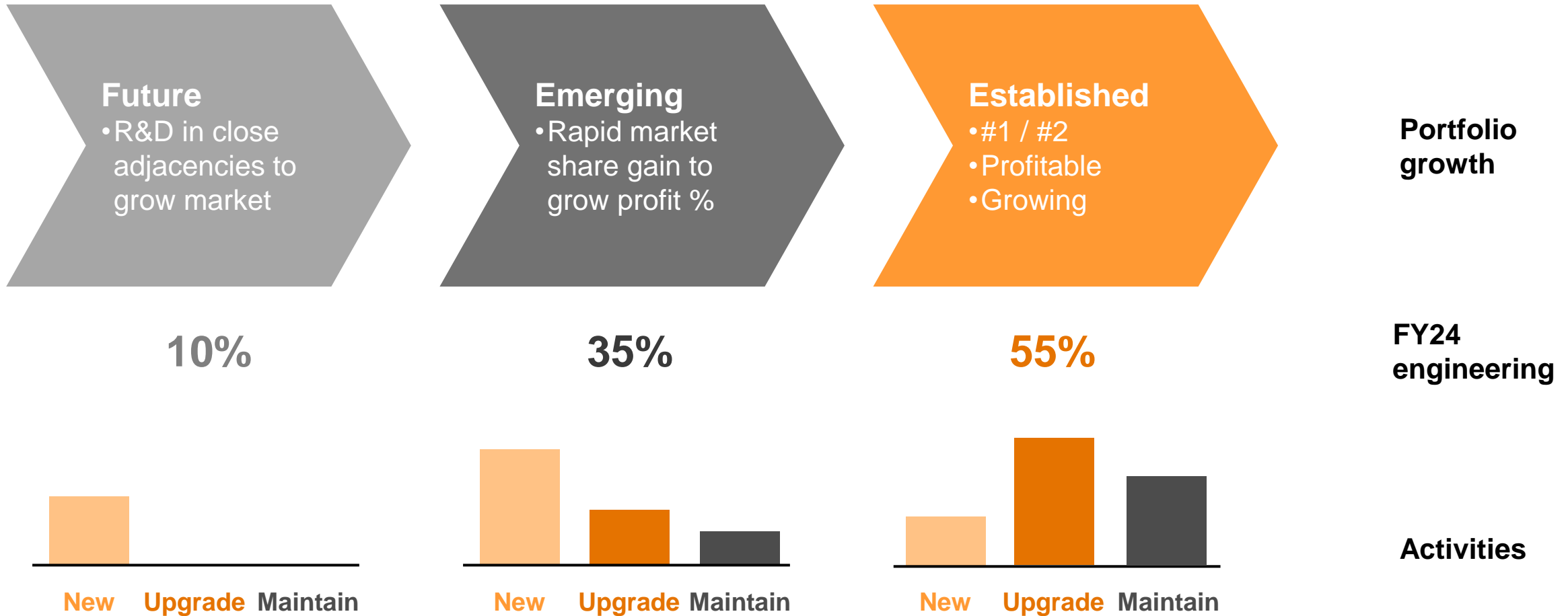



New product returns profile

Patient investing for long-term organic growth

Technology adoption cycle:

- Renishaw product development: 1 – 5 years
- Customer testing & evaluation: 0.5 – 2 years
- Design-in: 0.5 – 3 years
- Locked in for life: 2 – 20 years

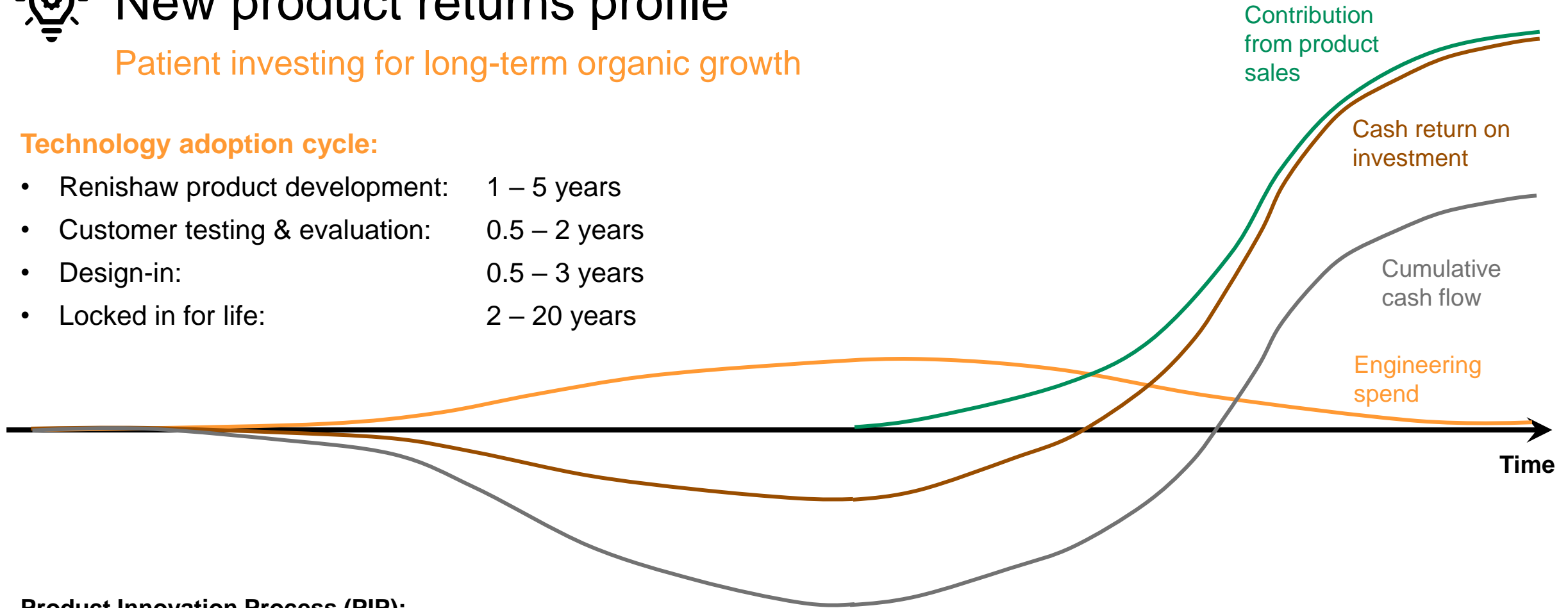

Product Innovation Process (PIP):



Sales & marketing

Global network providing expert sales, service & support

Sales & marketing investment:

- Grow local teams to support our strategic priorities and drive profitable growth
- Expand office network to support changing geographic patterns of customer demand
- Pay, logistics, travel & marketing expenses

Commercial focus for profitable growth:

Growing in existing markets

- Fitment levels
- Customer wins

Increasing technology value

- Systems & s/w
- Key accounts

Extending into new markets

- Route to market development

Sales & marketing spend & headcount

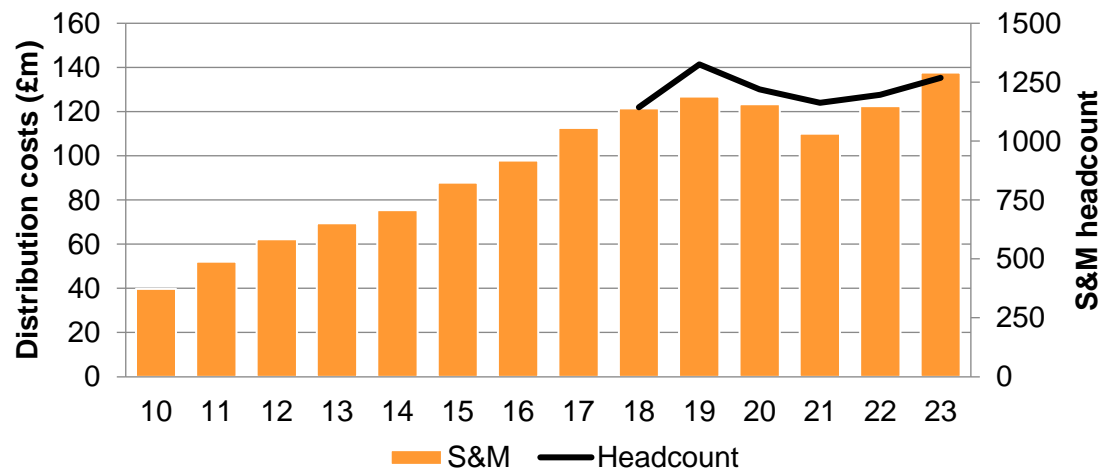

Sales & marketing spend as % of revenues

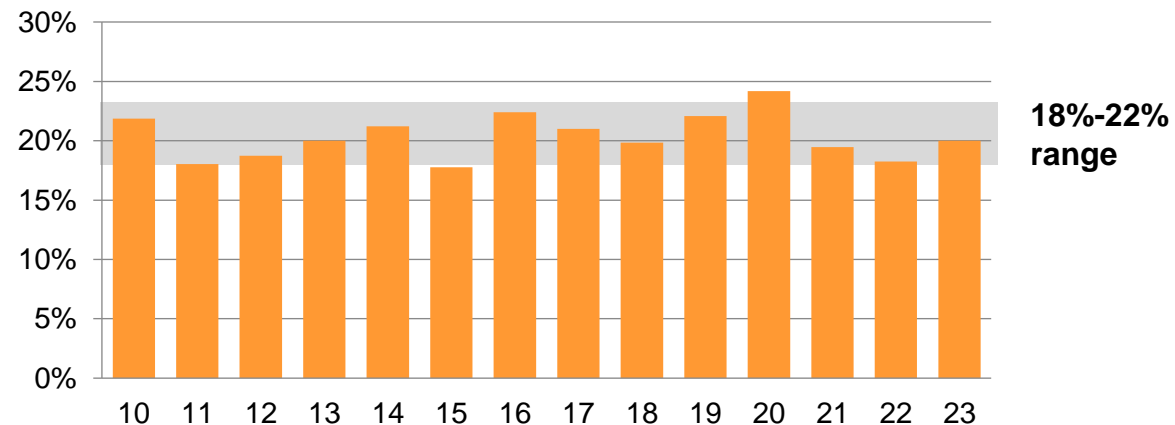

Growing our global network

Responding to changing demand patterns

Sales & marketing investment:

- Rapid China growth in 2010s, including large consumer electronics projects - 14 offices, 200 employees
- Expanded global sales network during 2010s to develop routes to market for emerging businesses
- Recent investment in Gulf, Korea, Thailand, Brazil
- Directing future investment into high-growth markets – e.g. India, Mexico

Overseas non-current assets

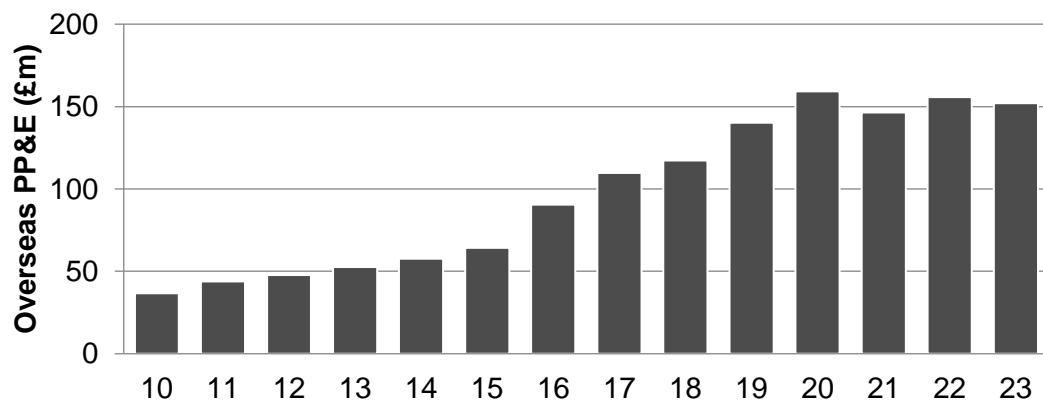

Revenue in major geographic markets

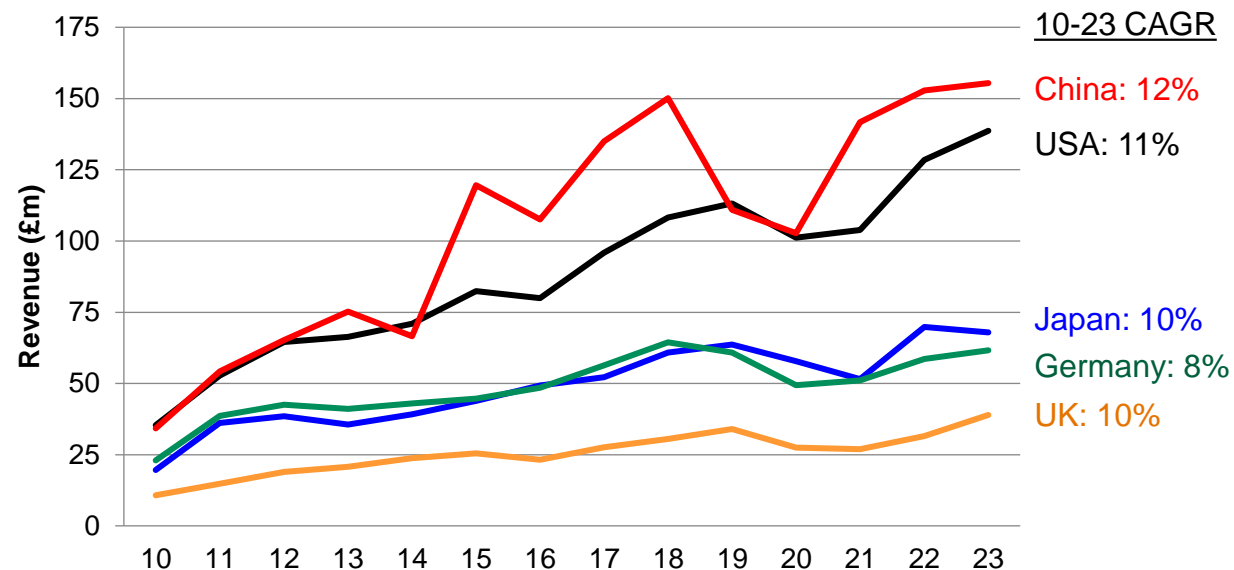

India

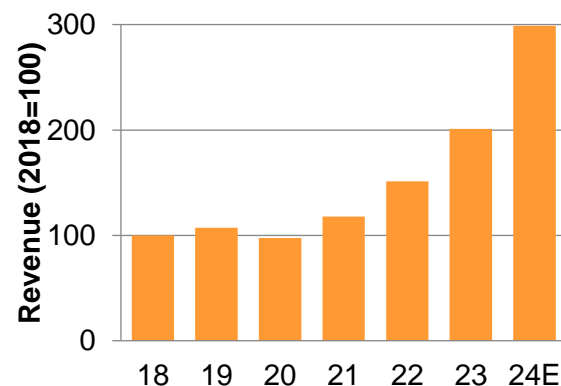

Mexico

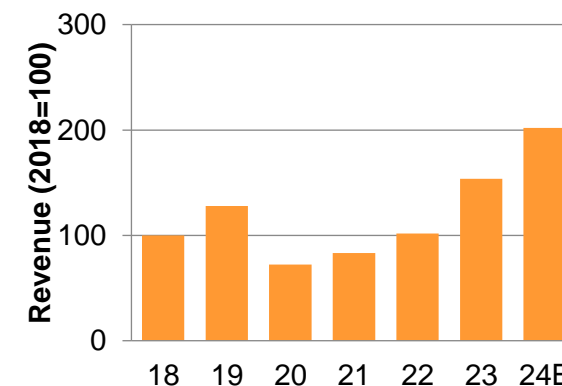



Capital expenditure

Building our sales, R&D and manufacturing capacity

Capital expenditure:

- Property, plant & equipment to grow our sales network, R&D facilities, and manufacturing capacity
- Capitalised R&D to develop our IP assets
- Extra capacity to allow rapid response to opportunities
- FY24 capex similar to FY23

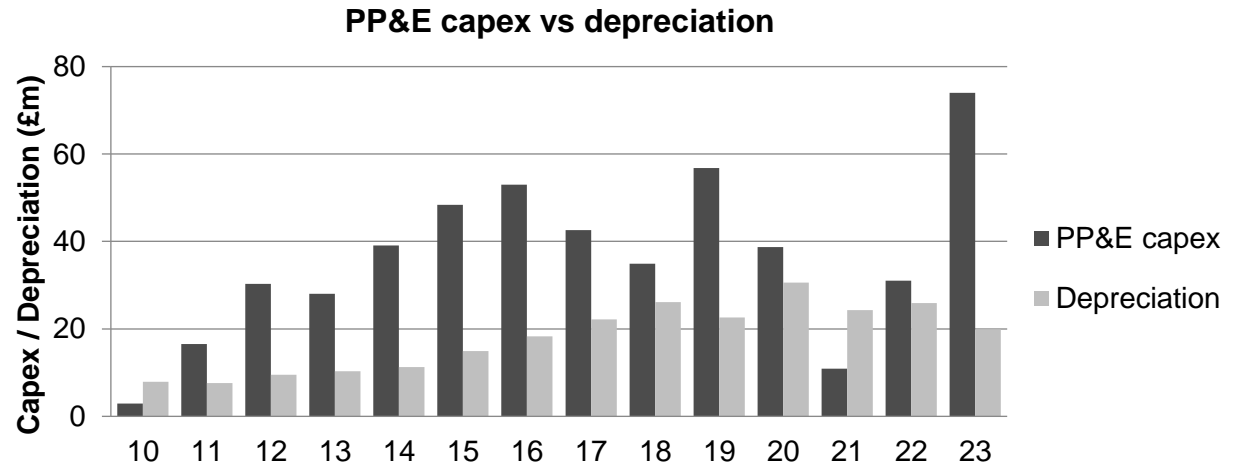
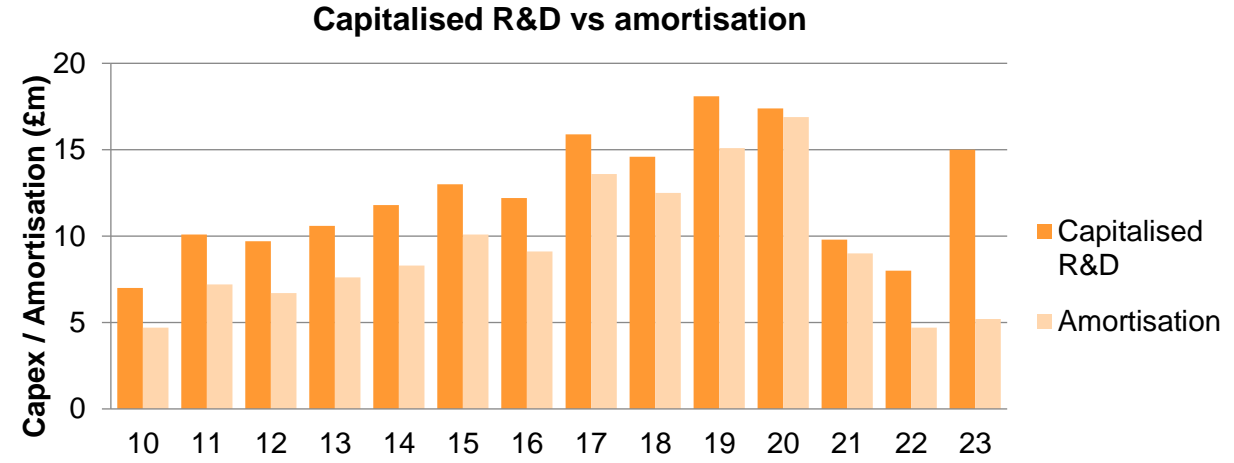
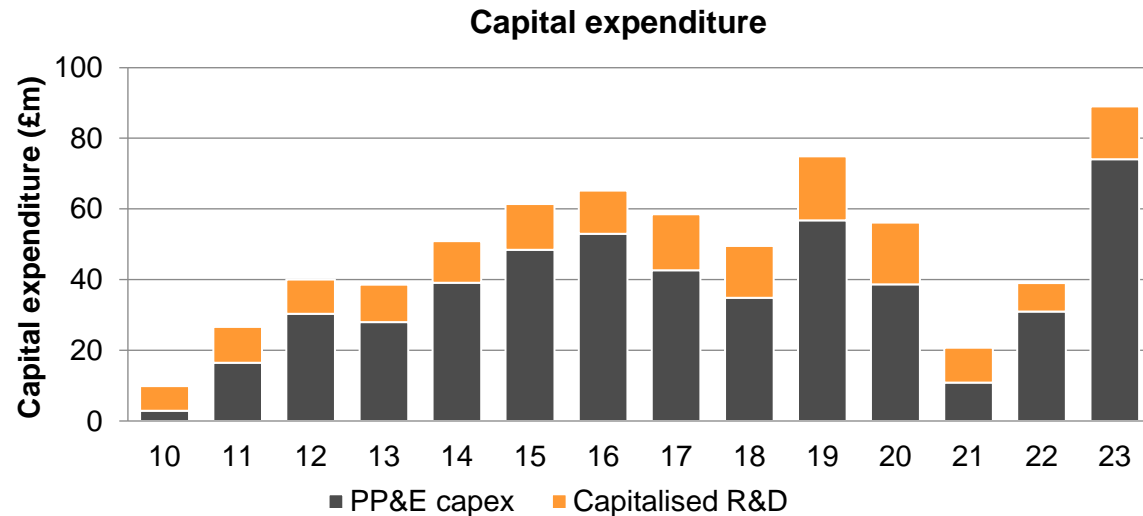

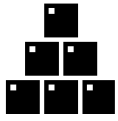

Working capital – inventories

Adjusting stocks in preparation for growth

Inventory as a competitive advantage:

- We build strong customer relationships by being a reliable and responsive supplier
- Our investment in inventory means that we are ready to respond to fluctuating market demand on short lead times
- Supply chain disruption in FY21 and FY22, followed by reduced customer demand from semicon equipment builders in FY23, left us over-stocked in some products
- £11m reduction in FY24 H1, whilst retaining resilience for future demand increases

Working capital – FY24 H1

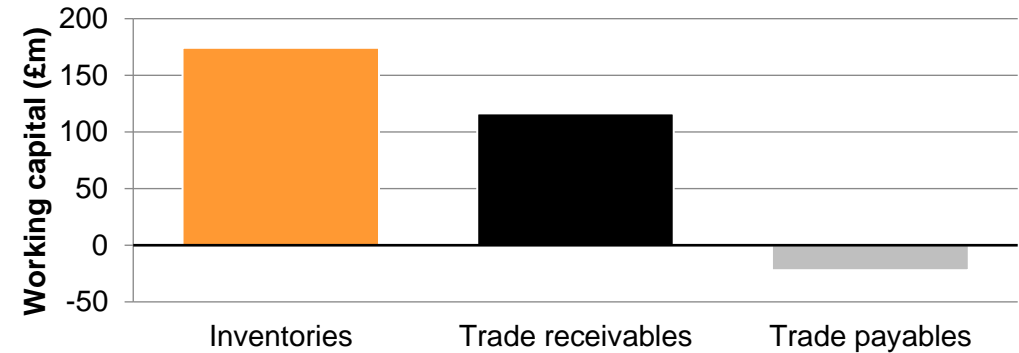

Inventories trends

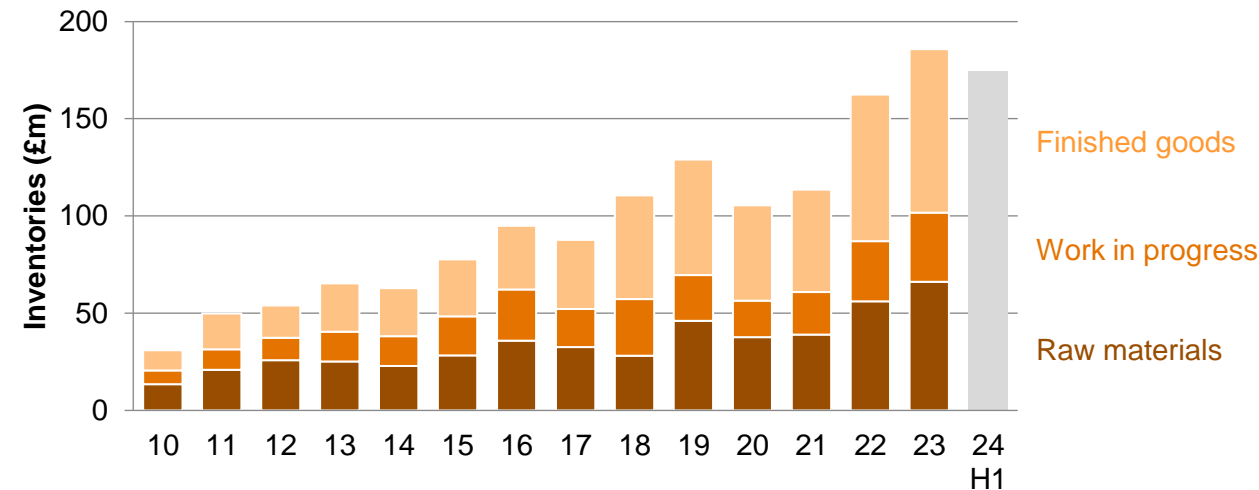

Notes

1. Debtor days = how long customer take to pay = trade receivables (inc. sales tax) / revenue x 365
2. Creditor days = how long Renishaw takes to pay suppliers = trade payables / material cost of sales x 365

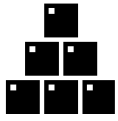

Working capital – debtors & creditors

Steady reduction in debtor & creditor days

Stable trading terms:

- Large projects in 2010s with consumer electronics contract manufacturers with long payment terms pushed up debtor days
- Steady recent reduction in debtor days as project sales have reduced in scale
- Creditor days rose in the post-covid period as we built up inventories – recently reversed

Working capital – FY24 H1

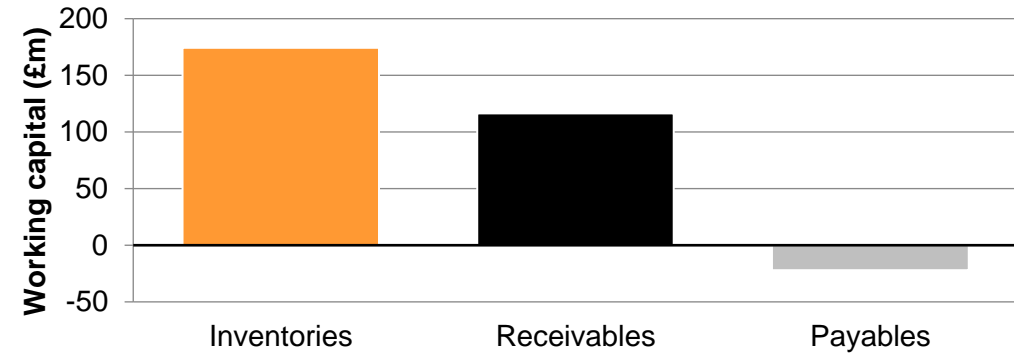

Debtor & creditor days

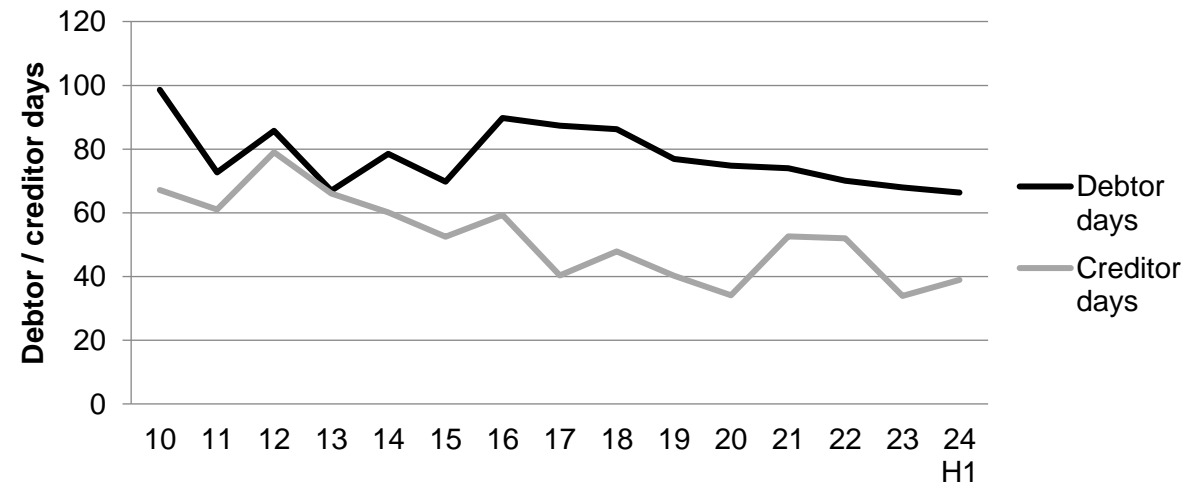

Notes

1. Debtor days = how long customers take to pay Renishaw = trade & finance lease receivables / revenue (i.c sales tax) x 365
2. Creditor days = how long Renishaw takes to pay suppliers = trade payables / (material cost of sales + other overheads) x 365

Growth investment topics

Capital allocation for through-cycle organic growth



Growth investment



Engineering

Maintain, upgrade & new products



Sales & marketing growth

Expand sales teams & routes to market

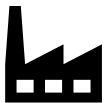

Capital expenditure

Grow our infrastructure & intellectual property

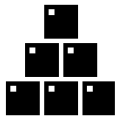

Working capital

Inventory & trading capital to support growth



Value creation & return on investment



Gross margin

Margin drivers & future trends



Return on invested capital

Robust balance sheet & solid returns



Gross margin (excluding engineering costs)

Factors driving recent margin variation

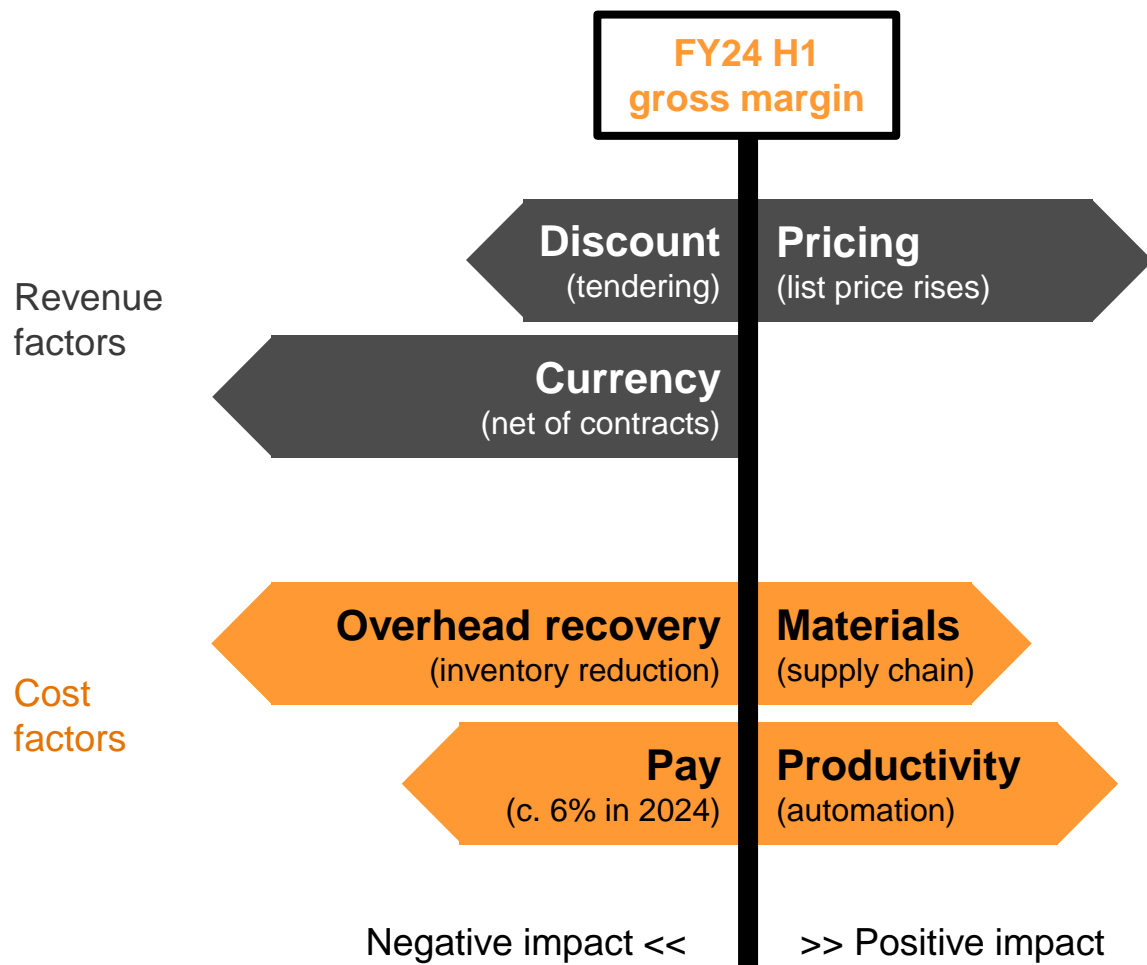

FY24 H1 gross margin is 3% lower than previous year

Revenue factors:

- List price rises in selected markets
- Partially offset by increased discounting to secure competitive tenders, notably in China
- Strengthening GBP against most major currencies, contracts in USD & EUR, not hedged against JPY

Cost factors:

- Lower overhead recovery as we reduce inventory during a period of lower demand, whilst maintaining our capacity in readiness for a cyclical upturn
- Material cost deflation & FX benefits
- Pay rises offset by productivity improvements & headcount control

Future margin evolution

Maintaining gross margins by driving productivity improvements

Historic margin trends

- Fluctuations in both GM% and EBIT% as we smooth fixed cost development through the cycle

Targeting mid 60% gross margin

Headwinds:

- Some emerging markets have structurally lower GM
- Pricing pressure is expected to continue
- Pay inflation remains significant in many countries

Productivity – increase output per person:

- Intelligent automation in manufacturing & logistics
- Key account strategy to drive sales efficiency
- Streamlined processes in engineering & administration

Gross margin (excl. engineering costs) & EBIT margin

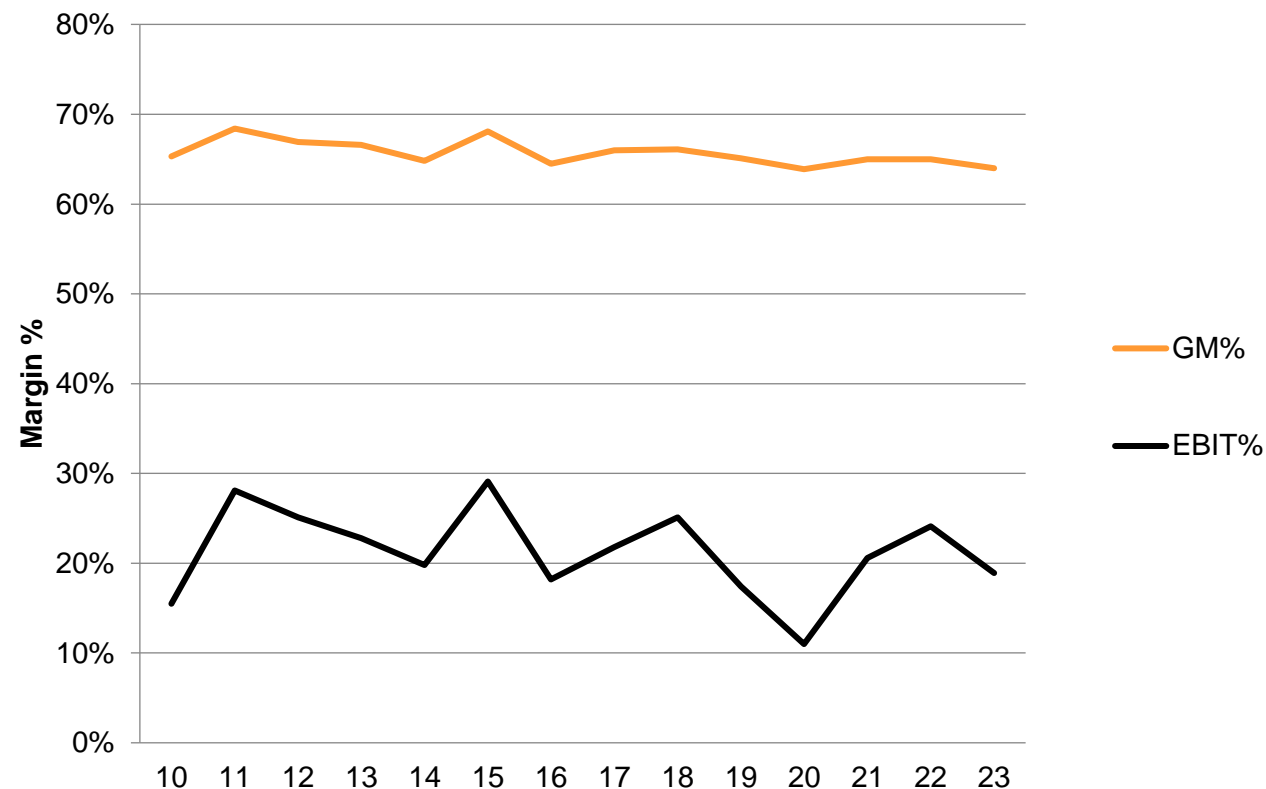



Return on capital

Robust balance sheet and solid returns

Assessing returns:

- Focus on ROIC – independent of capital structure
- ROIC typically > 15%
- Strong balance sheet to weather economic challenges
- More active recent investment in manufacturing capacity and working capital

Return on invested capital (ROIC ¹)

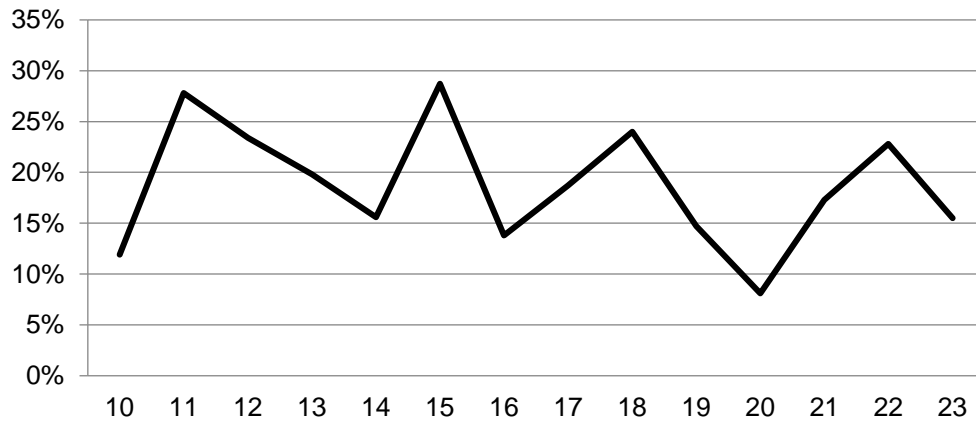

Invested capital

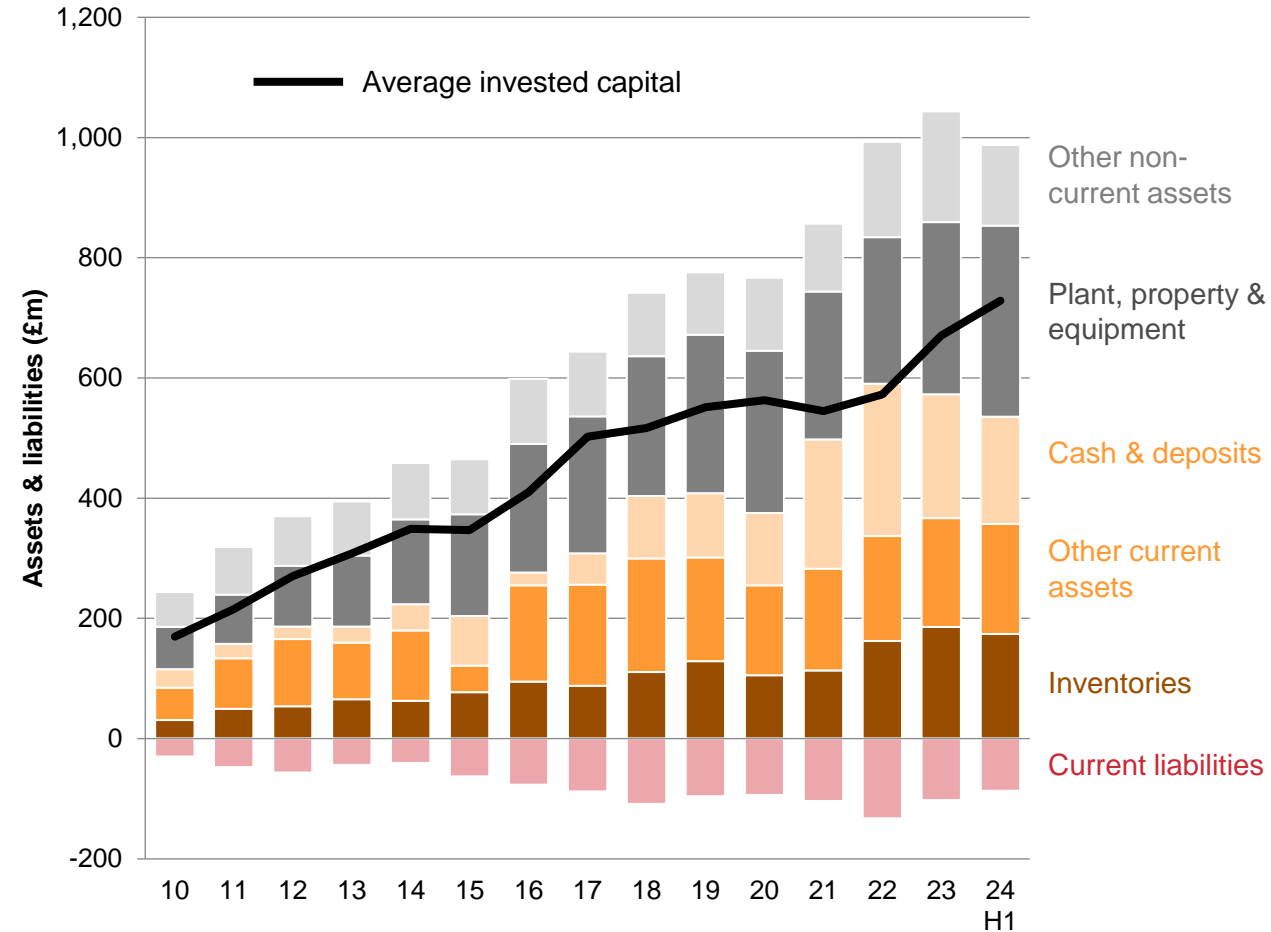

Notes

1. ROIC = return on invested capital = net operating profit after tax / average of (capital employed – cash & deposits)
2. Lower other non-current assets in FY24 H1 due to reduction in DB pension surplus following buy-in for UK scheme

Summary

Continuing to invest at >15% ROIC to support our through-cycle organic growth ambition



Engineering

Maintain, upgrade & new products



Sales & marketing growth

Expand sales teams & routes to market



Capital expenditure

Grow our infrastructure & intellectual property

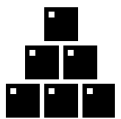

Working capital

Inventory & trading capital to support growth

FY23 growth investment

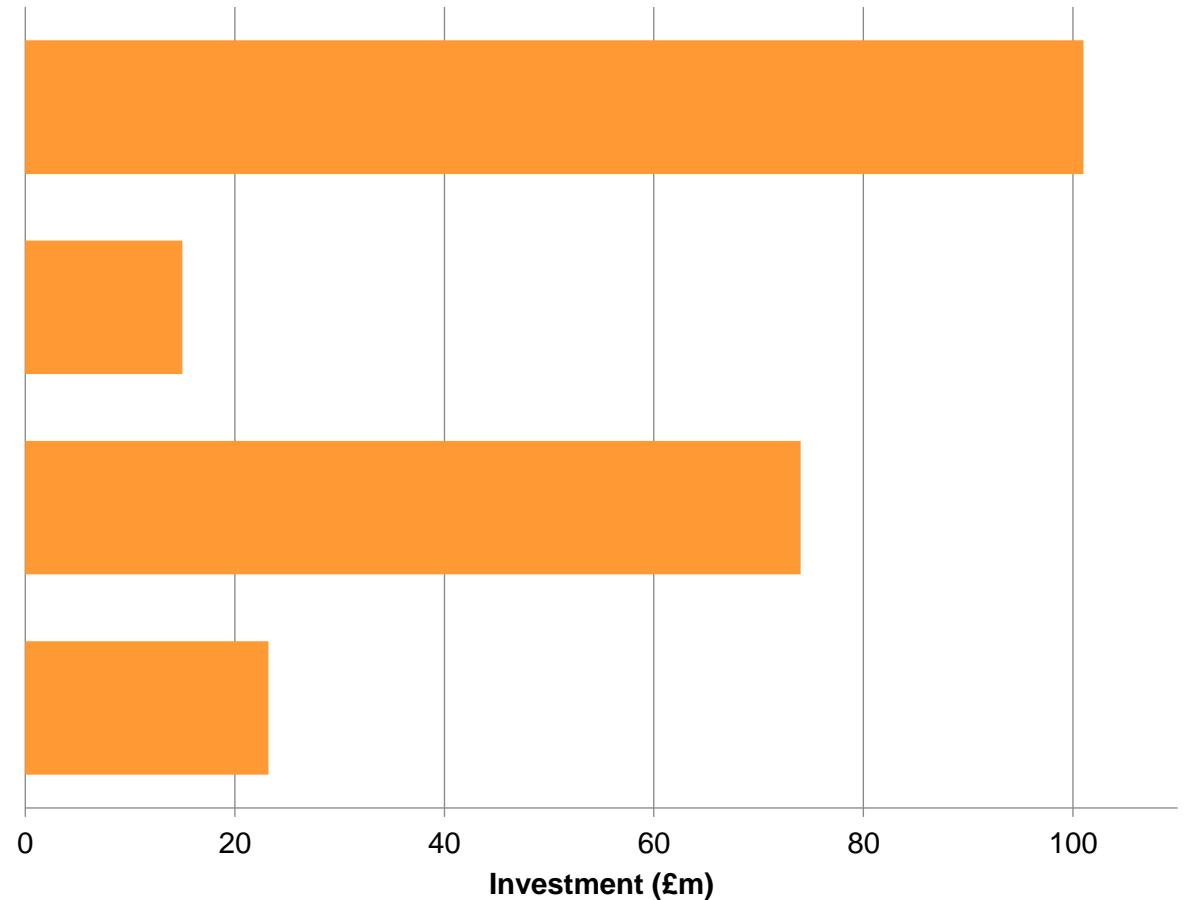

Q&A

Marc Saunders

**Director of Group Strategic
Development**

Allen Roberts

Group Finance Director

