

MCU W-3



Contents

General information	4
Warranty	4
Care of equipment	4
Changes to Renishaw products	4
Packaging	4
Regulations and conformance	5
EU and UK	5
USA	7
Canada	8
China	8
Safety	11
Operation	11
Maintenance	11
STOP buttons	11
MCU W-3 battery and charger	12
MCU W-3 safety function	14
Commissioning test	15
Recommended periodic testing	15
Functional safety data declaration	15
Certification	15
Warnings	16
Environmental conditions	17
References and associated documents	18
MCU W-3 manual control system description	19
Configuration	19
Features	20
System operation	22
Head mode	22
Indicator LEDs	22
Joystick enable	23
Bore teach	23
Joystick axis locks	24
Take point/cancel point	24

Axis select button	25
Joystick orientation button	26
Orbital mode	26
CMM/rotary table	26
Function buttons	27
Engage button	27
Keypad STOP button	28
STOP button	28
Emergency STOP button	28
Speed override	28
Probe disable button	29
MCU W-3 screen displays	29
Installation	32
Part numbers	32
Connecting the MCU W-3 to the UCC system	32
Fault finding	33
Fault finding of joystick or buttons	33
Cleaning	35
Requirements	36
Software requirements for installation	36
PSU specification requirements for MCU W-3 operation	36
MCU W-3 cradle – switching on and off	37
MCU W-3 joystick activation and deactivation	37
Pairing the MCU W-3 joystick with the cradle	38
The operating range of the MCU W-3 wireless communication	40
Use of the ID labels	41
MCU W-3 cradle LED indicators	42
Power LED	42
Pairing status LED	42
MCU W-3 battery operation	43
MCU W-3 first usage	43
Charging	46
Safety related to the MCU W-3 battery usage	46
Appendix 1 – Saleable countries	47

General information

Warranty

Renishaw plc warrants its equipment for a limited period (as set out in our Standard Terms and Conditions of Sale) provided that it is installed exactly as defined in associated Renishaw documentation.

Prior consent must be obtained from Renishaw if non-Renishaw equipment (for example, interfaces and/or cabling) is to be used or substituted. Failure to comply with this will invalidate the Renishaw warranty.

Claims under warranty must be made from authorised service centres only, which may be advised by the supplier or distributor.

Care of equipment

Renishaw probes and associated systems are precision tools used for obtaining precise measurements and must therefore be treated with care.

Changes to Renishaw products

Renishaw reserves the right to improve, change or modify its hardware or software without incurring any obligations to make changes to Renishaw equipment previously sold.

Packaging

To aid end user recycling and disposal the materials used in the different components of the packaging are stated here:

Packaging component	Material	94/62/EC code	94/62/EC number
Outer box	Corrugated fibreboard	PAP	20
Packaging insert	Corrugated fibreboard	PAP	20
Packing foam	Low density polyethylene	LDPE	4
Bag	Low density polyethylene	LDPE	4

Regulations and conformance

EU and UK

Declaration of conformity



Renishaw plc hereby declares that MCU W-3 complies with the essential requirements and other relevant provisions of:

- the applicable EU directives and regulations
- the relevant statutory instruments under UK law

Contact Renishaw plc or visit www.renishaw.com/EUCMM or www.renishaw.com/UKCMM for the full declarations.

EMC conformity

This equipment must be installed and used in accordance with this installation guide. This product is intended for industrial use only and should not be used in a residential area or connected to a low voltage power supply network which supplies buildings used for residential purposes.

REACH regulation

Information required by Article 33(1) of Regulation (EC) No. 1907/2006 (“REACH”) relating to products containing substances of very high concern (SVHCs) is available at www.renishaw.com/REACH.

Disposal of waste electrical and electronic equipment

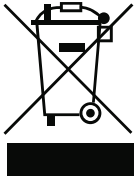

The use of this symbol on Renishaw products and/or accompanying documentation indicates that the product should not be mixed with the general household waste upon disposal. It is the responsibility of the end user to dispose of this product at a designated collection point for waste electrical and electronic equipment (WEEE) to enable reuse or recycling. Correct disposal of this product will help save valuable resources and prevent potential negative effects on the environment. For more information, please contact your local waste disposal service or Renishaw distributor.

Disposal of batteries



The use of this symbol on the batteries, packaging or accompanying documents indicates that used batteries should not be mixed with general household waste. Dispose of the used batteries at a designated collection point. This will prevent potential negative effects on the environment and human health which could otherwise arise from inappropriate waste handling. Contact your local authority or waste disposal service concerning the separate collection and disposal of batteries. All lithium and rechargeable batteries must be fully discharged or protected from short circuiting prior to disposal.

USA

FCC compliance statement



Information to user (47 CFR 15.105)

This equipment has been tested and found to comply with the limits for a Class A digital device, pursuant to Part 15 of the FCC rules. These limits are designed to provide reasonable protection against harmful interference when the equipment is operated in a commercial environment. This equipment generates, uses, and can radiate radio frequency energy and, if not installed and used in accordance with the instruction manual, may cause harmful interference to radio communications. Operation of this equipment in a residential area is likely to cause harmful interference, in which case you will be required to correct the interference at your own expense.

Information to user (47 CFR 15.21)

The user is cautioned that any changes or modifications not expressly approved by Renishaw plc or authorised representative could void the user's authority to operate the equipment.

Equipment label (47 CFR 15.19)

This device complies with part 15 of the FCC Rules. Operation is subject to the following two conditions:

1. This device may not cause harmful interference.
2. This device must accept any interference received, including interference that may cause undesired operation.

Canada

CAN ICES-003(A) / NMB-003(A) (Canada only)

This device contains licence-exempt transmitter(s)/receiver(s) that comply with Innovation, Science and Economic Development Canada's licence-exempt RSS(s). Operation is subject to the following two conditions:

This device may not cause interference.

This device must accept any interference, including interference that may cause undesired operation of the device.

L'émetteur/récepteur exempt de licence contenu dans le présent appareil est conforme aux CNR d'Innovation, Sciences et Développement économique Canada applicables aux appareils radio exempts de licence. L'exploitation est autorisée aux deux conditions suivantes :

L'appareil ne doit pas produire de brouillage;

L'appareil doit accepter tout brouillage radioélectrique subi, même si le brouillage est susceptible d'en compromettre le fonctionnement.

China





China RoHS

Contact Renishaw plc or visit www.renishaw.com/ChinaRoHSCMM for the full China RoHS tabulation.

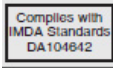

Radio type approvals for MCU W-3

Country name	Logo	Identification
Brazil	No logo applicable	ID : ANATEL: 02387-26-02812 Este equipamento não tem direito à proteção contra interferência prejudicial e não pode causar interferência em sistemas devidamente autorizados. Para maiores informações, consulte o site da ANATEL – www.anatel.gov.br
Canada	No logo applicable	IC: 1931B-BISMII This device contains licence-exempt transmitter(s)/ receiver(s) that comply with Innovation, Science and Economic Development Canada's licence-exempt RSS(s). Operation is subject to the following two conditions: This device may not cause interference. This device must accept any interference, including interference that may cause undesired operation of the device. L'émetteur/récepteur exempt de licence contenu dans le présent appareil est conforme aux CNR d'Innovation, Sciences et Développement économique Canada applicables aux appareils radio exempts de licence. L'exploitation est autorisée aux deux conditions suivantes : L'appareil ne doit pas produire de brouillage; L'appareil doit accepter tout brouillage radioélectrique subi, même si le brouillage est susceptible d'en compromettre le fonctionnement.
China	No logo applicable	CMIIT ID : Joystick – 26J99M1MX533 CMIIT ID : Cradle – 26J99M1M2399
EU Inc Türkiye		No ID required
India	No logo applicable	Joystick : ETA-SD-20250807031 Cradle : ETA-SD-20250807027
Japan	No logo applicable	MIC : 201 05215155

Country name	Logo	Identification
Singapore		No ID required
South Korea		Joystick : R-R-R1P-A-6934-0200 Cradle : R-R-R1P-A-6934-0300
Taiwan		Joystick : CCAL26LP0640T1 Cradle : CCAL26LP0630T1 「取得審驗證明之低功率射頻器材，非經核准，公司、商號或使用者均不得擅自變更頻率、加大功率或變更原設計之特性及功能。低功率射頻器材之使用不得影響飛航安全及干擾合法通信；經發現有干擾現象時，應 立即停用，並改善至無干擾時方得繼續使用。前述合法通信，指依電信管理法規定作業之無線電通信。低功率射頻器材須忍受合法通信或工業、科學及醫療用電波輻射性電機設備之干擾。」
UK		No ID required
USA		FCC ID: P1403B

Safety

CAUTION: Before unpacking and installing the MCU W-3 system, the user should carefully read the safety instructions below and ensure that they are followed at all times by all operators. Operators must be trained in the use and application of the MCU W-3 system and accompanying products, in the context of the machine it is fitted to, before being allowed to operate that machine.

Please ensure that you understand all safety instructions. Familiarisation with the MCU system components is recommended.

- The CMM should only be controlled from pre-determined zones or locations.
- The communication cable between the UCC controller and MCU W-3 cradle should be routed so to avoid a trip hazard.
- For safety reasons it is recommended that the joystick cradle is mounted outside the CMM working area.

Operation

If the equipment is used in a manner not specified by the manufacturer, any protection provided by the equipment may be impaired

- Do not position the MCU W-3 cradle in such a position that it would be difficult to operate the E-STOP button.
- These products are only to be used with the appropriate Renishaw UCC controller.
- Installation of the MCU W-3 must be performed by trained personnel.
- Do not edit any of the system files directly, only trained personnel may use the appropriate commissioning software package.

Maintenance

The MCU W-3 has no user serviceable parts. Should a unit become defective then it should be returned to the nearest Renishaw service centre.

STOP buttons

The MCU W-3 system offers three STOP buttons:

- Emergency STOP button – RED
- STOP button – GREY
- Keypad STOP button

MCU W-3 battery and charger

The MCU W-3 product is supplied with two third-party, primary protected, rechargeable lithium-ion batteries which are certified for safe use with the MCU W-3 joystick (EN61010). A battery charger is also supplied.

Additional batteries and chargers are available directly from the manufacturer.

Manufacturer = XTAR

Manufacturer website = www.xtar.cc

Manufacturer on-line shop = www.xtardirect.com

XTAR 18650 3500 mAh 10 A battery = XTAR 18650 3500 mAh 10 A Battery

Battery SKU	AB001094
Battery specification	XTAR 18650 3,500 mAh 10 A battery
Cycle life	800+
Nominal capacity	3,500 mAh
Nominal voltage	3.6 V
Max continuous discharge rate	10 A
Positive pole	Button top

Charger	AC331009 (from China) SC1 KT (Type-C) (from USA)
Kit contents	SC1 battery charger, USB-C cable and user manual
Charger specification	XTAR SC1 2A USB-C fast charger for Li-ion 18650/18700/20700/ 21700/22650/25500/26650 battery
Model	SC1
Type-C input	5 V, 2.1 A
Constant current	2 A × 1
Charge cut-off voltage	4.2 ±0.05 V
Charge cut-off current	<120 mA
Operating temperature	0 °C to +40 °C
Dimensions (L × W × H)	35 mm × 105 mm × 39 mm (1.38 in × 4.14 in × 1.54 in)
Net weight	37 g

NOTE: Refer to manufacturers' literature for further technical information including safe use in operation.

- Replace the batteries only with the exact make and type.
- Ensure that all batteries are always inserted with the correct polarity in accordance with the instructions in this manual and indicated on the product.
- Do not store the batteries in direct sunlight.
- Do not expose the batteries to water.
- Do not expose the batteries to heat or dispose of the batteries in a fire.
- Avoid forced discharge of the batteries.
- Do not short circuit the batteries.
- Do not disassemble, apply excessive pressure, pierce, deform or subject the batteries to impact.
- Do not swallow the batteries.
- Keep the batteries out of the reach of children.
- If the batteries are swollen or damaged do not use them in the product and exercise caution when handling them.
- Dispose of waste batteries in accordance with your local environmental and safety laws.

Ensure that you comply with international and national battery transport regulations when transporting batteries or this product with the batteries inserted. Lithium ion batteries are classified as dangerous goods for transportation and require labelling and packaging in accordance with the dangerous goods regulations before being offered for transportation. To reduce the risk of shipment delays, should you need to return this product to Renishaw for any reason, do not return any batteries.

WARNING: Use only rechargeable batteries as specified.

Do not use non-rechargeable (primary) batteries. Risk of explosion, fire, or equipment damage.

MCU W-3 safety function

The safety function which the MCU W-3 provides is:

The MCU W-3 shall provide a functionally safe emergency stop button.

An MCU W-3 is intended to be assembled with other safety rated components to form a machine safety system which is then assessed against ISO 13849 as a complete system.

The following restrictions apply to this claim:

- The system in which the MCU W-3 is installed must be assessed as complying with ISO 13849-1.
- The system installer shall perform a verified test during commissioning.
- The MCU W-3 shall only be used with Renishaw controllers and is not supported by any third-party equipment.

Fault exclusions

The following actions will invalidate the Functional Safety certification of the MCU W-3 E-STOP system:

- Failure to follow the instructions contained within this installation manual.
- Dismantling of the MCU W-3.
- Operating the system outside of the limits specified within this installation manual.

Additional information for use

Response time	There is no delay in opening the button contacts.
Indications and alarms	There are no indicators or alarms.
Muting and suspension of safety functions	There is no muting function.
Control modes and reset	There are no modes or reset.
Maintenance	Maintenance is not possible and the unit shall not be dismantled for any reason.
Maintenance check lists	n/a
How to access and replace the parts	n/a
Means for easy and safe trouble shooting	n/a
Test intervals	The button shall be tested once per day.

Commissioning test

The following checks MUST be performed following installation and commissioning of the MCU W-3 for the first time.

E-STOP test	Actuate the E-STOP button and observation that the system E-STOP function is immediately triggered.
--------------------	---

Recommended periodic testing

It is recommended that the E-STOP button is tested periodically. The frequency of test should be determined by system level risk assessment but is recommended at no more than once per day.

Functional safety data declaration

Product identification	MCU W-3
-------------------------------	---------

ISO13849 safety data

MTTFd (years)	100
Diagnostic coverage	None
Category	1
Performance level	c
Lifetime/replacement limits	20 years

Certification

MCU W-3 functional safety certificate No. FSP 26001

Renishaw plc declares that the product shown by this installation guide meet the requirements of:

ISO 13849-1:2023 and ISO 13849-2:2012

when used as an element/subsystem in safety related systems performing safety functions requiring up to and including:

Category 1, PLc

Warnings

Beware of unexpected movement of the CMM or probe system. The user should remain outside of the full working envelope of probe head and stylus. The machine supplier should ensure the user is aware of the full working envelope of the system.

In all applications involving the use of machine tools or CMMs, eye protection is recommended.

It is the machine supplier's responsibility to ensure that the user is made aware of any hazards involved in operation, including those mentioned in Renishaw product documentation, and to ensure that adequate guards and safety interlocks are provided.

The product and the system components contain no user serviceable parts. No attempt should be made to disassemble any part of the product. In the event of a problem please contact your supplier for assistance.

The cables must meet Renishaw specifications. Incorrect cabling could cause damage to the equipment.

Probe disable will prevent machine backing off in the event of a probe collision.

The MCU W-3 must be transported in Renishaw supplied packaging.

This equipment is not suitable for use in a potentially explosive atmosphere.

Environmental conditions

Indoor use	IP30
Altitude	Up to 2,000 m (6561.68 ft)
Operating temperature	+10 °C to +40 °C
Storage temperature	-20 °C to +50 °C (recommended at 28 °C)*
Relative humidity	Relative humidity 80% maximum (non-condensing) for temperatures up to +31 °C. Linear decrease to 50% at +40 °C.
Pollution degree	2**
Overvoltage	OVCI
UCC output connector (SK1)	9-way D-sub female 6.5 A V-0 DIN 41652 UL 1977 ECBT2.E102079

* Storing the MCU W-3 battery at high temperatures is not recommended because it prematurely ages the battery.

** As defined by BS EN 61010-1:2001 section 3.6.6.2. Normally, only non-conductive pollution occurs. Occasionally, temporary conduction caused by condensation occurs.

References and associated documents

It is recommended that the following documentation is referenced when installing an MCU:

Renishaw documents

Title	Document number
Installation guide: SPA2-2	H-1000-5247
Installation guide: SPA3-2	H-1000-5364
Installation guide: UCC T5	H-1000-7573
Installation guide: UCC T3-2	H-1000-5254
Installation guide: UCC T3 PLUS and UCC S3 CMM controller	H-1000-2118
Installation guide: UCC S5 REVO-2 CMM controller	H-1000-7598

External documents

National and international standards including the following may be applicable to the finished machine or installation:

BS EN ISO 12100:2010 (Safety of machinery – General principles for design – Risk assessment and risk reduction).

BS EN 60204-1:2018+A1:2025 – Safety of machinery – Electrical equipment of machines – Part 1: General requirements.

IEC 60204-1:2016/AMD1:2021 – Safety of machinery – Electrical equipment of machines – Part 1: General requirements.

MCU W-3 manual control system description

The MCU W-3 wireless manual control unit is a CMM joystick designed for use with Renishaw's range of UCC controllers. Based on the MCU5-2 joystick design, the MCU W-3 uses modern battery and wireless technology to provide the joystick with a maximum range of 25 m and over eight hours between battery changes. A spare battery and remote charger are included in the kit.

NOTE: MCU W-3 is not compatible with UCC1 and requires UCCsuite 4.9 or later.

Configuration

All MCU units can be configured to match the customer's requirements using Renishaw UCCassist software. Contact Renishaw CMM support for details.

Features

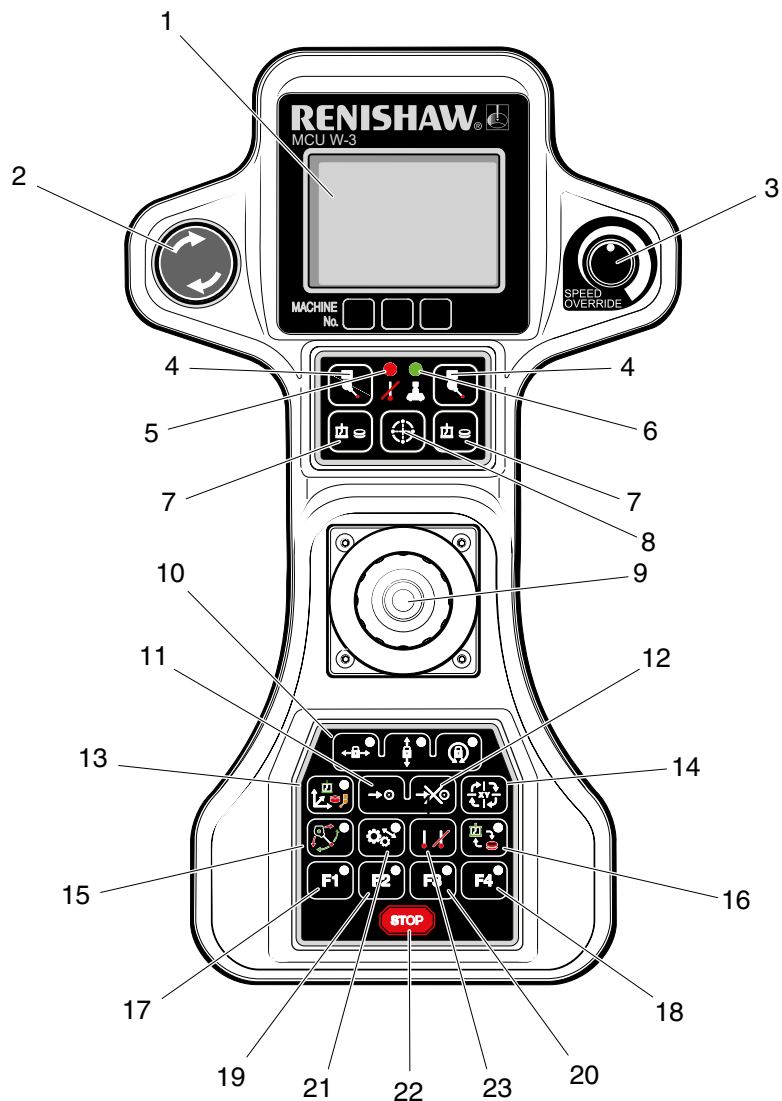

Key	Description	Key	Description
1	LCD screen	13	Joystick co-ordinate system (axis select)
2	Stop button	14	Joystick orientation
3	Speed override	15	Switch between orbital mode and head mode
4	Joystick enabled head mode (see '6' and '15')	16	CMM movement or rotary table
5	Probe disabled LED	17	F1 function
6	Joystick enabled LED	18	F4 function
7	Joystick control of CMM or rotary table (see '6' and '16')	19	F2 function
8	Bore teach	20	F3 function
9	3-axis joystick with push button	21	Engage servos
10	Joystick locks (three separate buttons)	22	Stop
11	Take point	23	Probe disabled (see '5')
12	Cancel point		

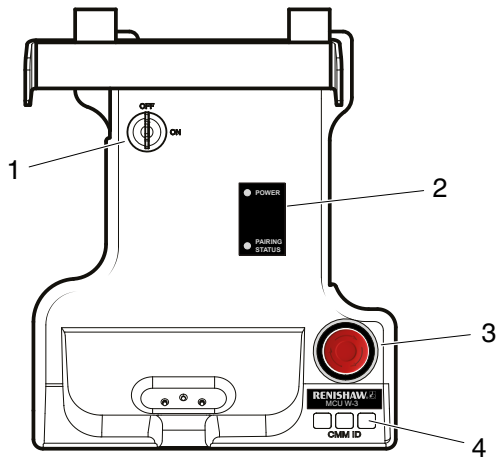

Key	Description	Key	Description
1	Cradle key	3	Emergency stop button (red)
2	LED indicators	4	ID labels

System operation

All three axis movements are controlled from the one joystick. Moving the joystick left, right, backwards and forwards controls the CMM X and Y movements. The Z-axis is controlled by twisting the joystick clockwise and anti-clockwise (configurable)*.

If a trigger event occurs during joystick operation, the CMM will stop and back away from the surface along the vector that it was travelling. After the back off operation, it is necessary for the joystick to return to its null position for a set period of time before the joystick will permit movement of the CMM. The default value is 0.05 seconds*. The back-off speeds and distances are defined by the UCC configuration settings*.

* These values and configuration settings will have been set by your CMM service provider.

Head mode

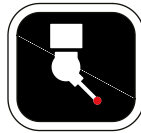

The head mode button(s) enable movement of the head. Pushing the joystick forwards and backwards will operate the A-axis and twisting the joystick will operate the B-axis.

When in orbital mode (LED lit) the head and machine move relative to the stylus ball.

Indicator LEDs

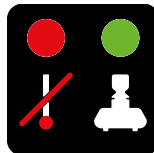

The left LED indicates that the probe is disabled. In this mode, if the stylus is driven into a surface the CMM will NOT stop.

The right LED indicates that the joystick is enabled i.e. the joystick will move the CMM or head when deflected.

Joystick enable



The joystick enable button(s) are intended to be used to prevent the accidental movement of the machine. Two actions are required to initiate CMM motion: press joystick enable button and operate the joystick.

Holding this button down enables movement of the CMM or rotary table (dependent upon the status of the CMM/rotary table button).

With CMM selected:

- Twisting the joystick moves the Z-axis.
- Left, right, backwards and forwards moves the X and Y-axes.

Bore teach



Place the stylus into a bore and press the 'joystick enable' and 'bore teach' buttons simultaneously:

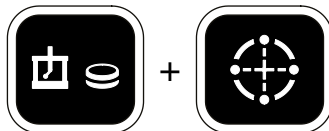

The machine will take x4 points (0,90,180 and 270) perpendicular to the stylus axis.

If the 'head mode' and 'bore teach' buttons are pressed simultaneously the bore is measured with head touches (PH20 and REVO/RSP2 only):

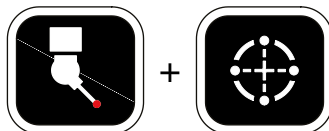

Joystick axis locks

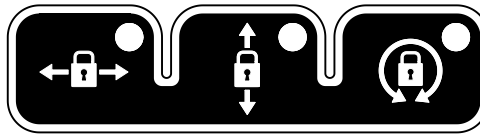

These permit the locking of one or more axes of the CMM, ignoring any joystick deflections for that axis. On each of the axis lock buttons there is an LED indicator that will light red when the respective axis is locked. On the MCU display there will also be a padlock symbol next to the respective axis (see below). These buttons toggle the lock on/off.

NOTE: If an axis lock is released when the joystick is deflected, that axis is immediately free to move.

NOTE: When the CMM joystick orientation function is operated, the axis locks will be transposed on the MCU.

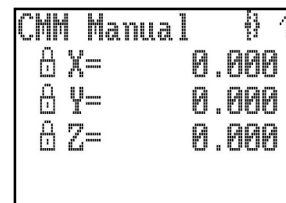
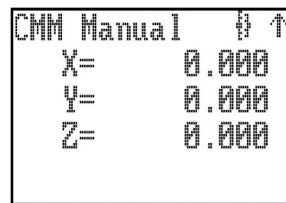

When the MCU W-3 is in head mode, the axis locks are applied to the relevant head axes. When the joystick is in head mode and a REVO/REVO-2/PH20 head is fitted, the left/right axis lock button is used to initialise and cancel 'SNAP ON'. 'SNAP ON' is the ability to move the head to the nearest multiple of a defined head angle. In UCCassist-2 the variable can be set to define the resolution of manual head moves (for example, 5°). These axis locks will only be active during manual (MCU) controlled CMM movements. When the CMM is under DCC (direct computer control) operation, all axis locks will be released and re-latched when returning to manual operation.

Take point/cancel point

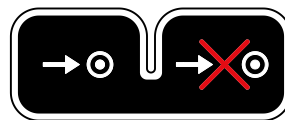

This button is designed to allow the user to record or cancel chosen machine positions. When a program is being generated by the teach and learn method, the take point button is used to permit the CMM to record a waypoint and use it in the program. Use of the cancel point button will indicate to the application software that the point just taken (either a touch point or a position generated by the take point button) should be removed from the program. The cancelling process can be repeated many times and the front-end program will use it to delete multiple stored points.

NOTE: When the take point button is pressed, the machine's XYZ position will be recorded and a waypoint created.

Axis select button



The axis select button changes the CMM motion in any one of three different axis systems – machine, part or stylus:

Machine axis (green LED)



In this axis system, the joystick directly controls the machine axes, i.e. a forward deflection of the joystick produces a pure Y+ movement of the CMM. This is the default machine setting when the machine is initialised.

Part axis (red LED)



In this axis system, the joystick controls the machine within the current part axis system. i.e. a forward deflection of the joystick produces a movement in the part Y+ direction. This could be a compound of two or three machine axes.

Stylus axis (amber LED)



In this axis system, the joystick controls the machine axes in the axis system of the selected stylus. i.e. a twist (Z) deflection of the joystick produces a movement along the axis of the probe stylus. This could be a compound of two or three machine axes. The stylus axis is a secondary part co-ordinate system, applicable only to the MCU joystick, and this needs to be updated by the application software to reflect the active stylus axis.

The axis system in which the MCU is moving the CMM (machine, part co-ordinate or stylus) is indicated on the LCD by an M, P or S and by a tri-colour LED mounted below the axis select button. Pressing the axis select button will enable the user to scroll through the three axis systems.

To change to the required axis system the axis select button must be pressed and held on the desired axis system. This selection is confirmed by simultaneously pressing the joystick enable switch. Both switches can then be released. This change procedure prevents unintentional changing of the axis system which could give unexpected machine movement.

Joystick orientation button

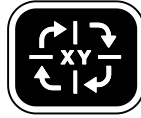

The joystick orientation button changes the mapping of joystick deflection direction to CMM axis. This allows the user to move freely around any side of the CMM and transpose the joystick orientation such that the machine's X-axis and Y-axis correspond to joystick direction of deflection. If any axis lock is asserted and the joystick orientation is changed then the relative axis lock will also be transposed.

An arrow in the top right of the LCD indicates the orientation of the MCU. Pressing the joystick orientation button will enable the user to scroll through the four operational positions. The direction of the arrow indicates the +Y axis direction of the machine when the machine co-ordinate system is in force.

NOTE: When switching the system to CMM auto mode, the joystick orientation feature will drop out and then be reasserted when the system is placed into CMM manual mode.

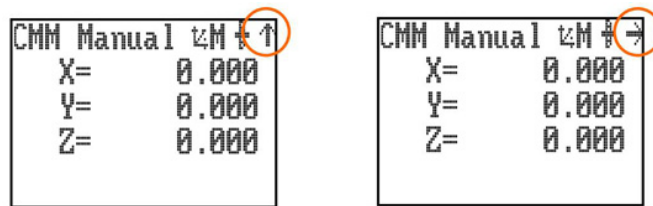

Orbital mode

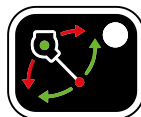

When head mode is active and this button is pressed, joystick deflection rotates the CMM around the stylus tip.

CMM/rotary table

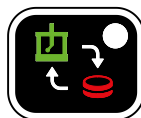

This button switches between CMM and rotary table operation.

If there is no rotary table this button has no effect. The rotary table is set up during commissioning in UCCassist-2.

Function buttons



The application software can define the function buttons. Their status can be read at any time and in any mode. These buttons have no effect on the UCC controller as they are solely for the use of the front-end software. The associated keypad LEDs can also be switched on and off at any time. For example, one of the buttons may be used to initiate a circle measurement command when the system is in a manual mode and is being used for teach and learn programming.

Engage button



The engage button gives the CMM user the ability to engage or disengage the servos whilst the CMM is in manual mode. This button is configured as a toggle switch and has an associated LED to indicate the servo status. The LED identifies the various operational states as listed below. A symbol at the top of the LCD screen (shown below) also indicates whether the servos are engaged.

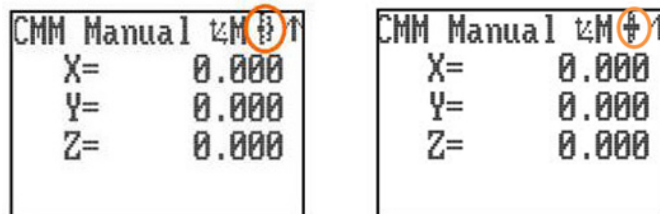

LED off – The CMM servos are disengaged.

LED amber – The servos are in the process of engaging.

LED red – The servos are engaged but the joystick is not enabled.

LED green – The servos are engaged and the joystick is enabled and ready.

Operating the disengage switch disengages only the CMM axes, it does not disengage the REVO or PH20.

Keypad STOP button



The STOP button gives the operator the ability to rapidly stop the CMM, REVO head and PH20 without disengaging. When the CMM has stopped, the system stays in hold state with both the CMM and head engaged.

STOP button

This is the grey STOP button mounted on the MCU W-3 joystick. When this button is pressed, all CMM and motorised head motion is halted.

Emergency STOP button

A red emergency STOP button is mounted on the MCU W-3 cradle which is hard wired to the UCC controller. When this switch is operated power to all the CMM axes is removed.

Speed override

If the joystick is taken out of range while the CMM is moving in automatic mode, the loss of the radio link will stop the CMM. If the speed control is changed while the joystick is out of range, the following actions are required when the joystick is reconnected.

- If the new demanded speed is lower than the value set before the link was lost then the CMM will immediately slow down to the new speed when the joystick link is reconnected.
- If the new demanded speed is higher than the value set before the link was lost then, when the joystick link is reconnected, the CMM will keep on moving at the old speed but the display of % speed will be reversed (white on black as shown below). The speed will be frozen until the speed control is turned down through the old speed value. The speed control will then again be functional.

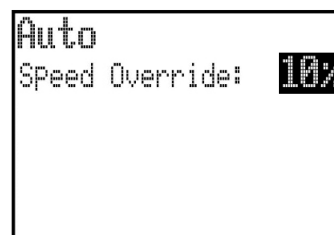
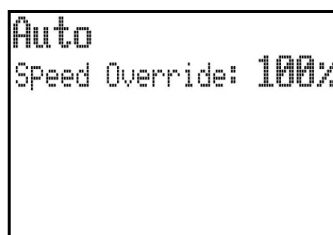

Probe disable button







The probe disable button gives the CMM user the ability to move the CMM while the probe is triggered or disconnected by disabling the probe trigger signal.

WARNING: When operating in this mode the probe is disabled and therefore probe contact with a surface will NOT stop the CMM. No measured data will be returned to the CMM host computer.

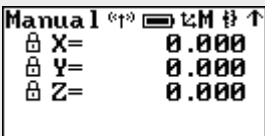
The probe disable function will only work while in manual mode and cannot be applied while in automatic/DCC mode. To disable the probe, press and hold the joystick enable button and then press the probe disable button. The CMM can now be moved irrespective of the probe trigger status. Releasing the joystick enable button cancels the probe disable function. In all modes the application of probe disable is confirmed by the red probe disabled LED being illuminated.



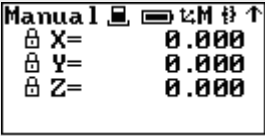

MCU W-3 screen displays

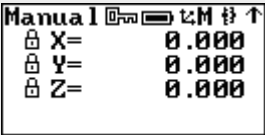
Wireless communication	
	Wireless communication is activated.
	Manual operation, wireless communication – ON, battery – fully charged.
	Joystick pairing.
	Pairing lost, (out of range or loss of power to cradle) waiting for the connection.
	Pairing failed.

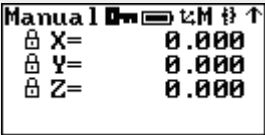
Joystick docked	
	MCU W-3 joystick is docked in the cradle.
	Manual operation, MCU W-3 joystick docked, battery fully charged.

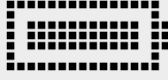
The lock	
	The key in the MCU W-3 cradle is in the locked position, the MCU W-3 joystick is deactivated and manipulation of it will not result in any CMM movement. The power status is amber.
	Manual operation, MCU W-3 joystick locked/disabled, battery fully charged.

Out of range	
	The link has been lost due to the MCU W-3 joystick being out of range or the power supply to the MCU W-3 cradle failing.
	Manual operation, MCU W-3 joystick out of range, battery fully charged.

Battery status				
Battery full	Battery 80% full	Battery half full	Battery empty	Battery fault/ missing*
				

* **NOTE:** Replace the battery with a known charged one.

NOTE: The MCU W-3 cradle only charges the battery to 80%.

Power-saving screen back light

If the joystick has not been used for 60 seconds, the back light turns off.

To activate the screen back light press the joystick enable button.

Installation

Part numbers

- A-6934-0400 – MCU W-3 kit (including batteries)

Comprises of:

- MCU W-3 joystick – model number A-6934-0200
- MCU W-3 cradle – model number A-6934-0300

This kit is provided with a 5 m flexible joystick cable. Replacement cables are available from your machine supplier or directly from Renishaw.

- 5 m cable – A-1016-8098
- 10 m cable – A-1016-8099

Connecting the MCU W-3 to the UCC system

The MCU W-3 joystick kits include a 5 m flexible cable provided as standard. The cable is fitted from 9-pin D connector on the rear of MCU to a 9-pin D connector on the rear of the SPA3-2.

Connecting to the SPA3-2

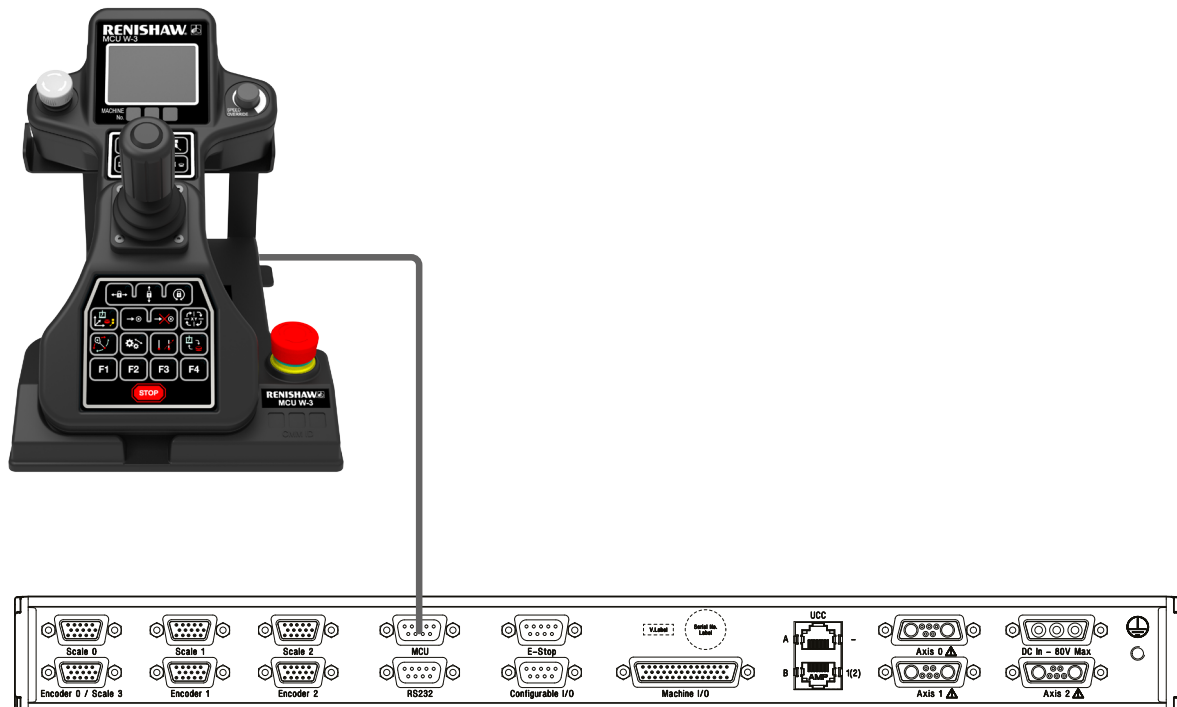

The emergency stop button has a dedicated circuit that is fed directly into the rear of the SPA3-2 servo power amplifier or UCC controller.

Fault finding

Many operating problems can be solved by checking the MCU W-3 status LEDs, the system configuration and current operating conditions.

NOTE: As with most cable connected ancillary equipment, the actual cable is the most vulnerable part, particularly with a joystick where it can be trapped by the part under inspection, pulled if caught by machine motion, trodden on, run over, etc. If any malfunction with the MCU occurs, the first step should be to examine the cable.

Fault finding of joystick or buttons

There is a comprehensive test program for the MCU joystick operation and button function within UCCassist-2. Please refer to the UCCassist-2 user guide (Renishaw part number H-1000-5224) for details.

The joystick will not move the CMM

Several conditions have to be satisfied before joystick controlled moves can be made:

- The joystick must be connected to the UCC and have been set up in the configuration file.
- The joystick must be 'enabled'.
- The MCU 'joystick enable' button must be pressed down.
- The axis locks must not be applied.
- The CMM application software must be in manual (joystick) mode.
- The probe must not be 'deflected', unless probe disable is on.
- No limit switches should be open, unless disabled.
- The CMM position must be inside all 'soft limits' if these are enabled.
- MCU W-3 cradle key not in the off position.

The speeds are too low or too high

- Check the correctness of the joystick speeds and accelerations that are set in the UCC configuration file.
- Check the operation of the fast/slow switch – higher speeds will be obtained when this switch is active.

The motors disengage during joystick operation

- If the joystick maximum speed is set to a high value, the machine may be able to exceed the maximum move speed and may cause an overspeed error.
- If the joystick maximum acceleration is set too high, the motor signals may attempt to exceed the overdrive limits and cause an overdrive fault.
- If the system proportional gains are set too high, or the velocity gains are too low, an overdrive fault may occur.

Speed override does not work correctly

- This feature must be enabled separately from the general joystick enabling function. It is an entry in the UCC configuration file.

NOTE: Speed override ONLY works on DCC moves and scanning. It is not operational when the MCU is in manual (joystick) mode.

Servos will not engage

- E-STOP not connected correctly.
- E-STOP still asserted.
- An outer limit switch is activated.
- Cradle key in the OFF position.

No screen display

- Check cable connection.
- Charge/replace battery.
- Place joystick on the cradle.



showing and battery present

- Check the battery polarity.
- Place the battery in the remote charger and recharge.

Cleaning

The MCU W-3 may be kept clean by wiping with a clean, damp, lint-free cloth.

CAUTION: Do not use solvents.

Replacement connection cables can be purchased through the CMM provider or direct from Renishaw:

CAUTION: Always follow the safety instructions given in this guide. Failure to do so could adversely affect the performance of the MCU W-3 system and/or lead to personal injury.

NOTE: The external surfaces of all system components can be cleaned with a water damped cloth but all parts should be kept dry. Keep MCU W-3 contacts clean and free from dirt using non-abrasive material.

Requirements

Software requirements for installation

The required version of UCCsuite:

- UCCsuite 4.9 and later

PSU specification requirements for MCU W-3 operation

Should a replacement PSU be required it is recommended that it be purchased from Renishaw, or it must meet the following specification:

- Output +24 Vdc, 1.67 A, 40 W.
- 2.5 mm dc jack connector (centre positive).
- To comply with electrical safety legislation the supply negative must be connected to the earth of the ac input, must be single fault tolerant and approved to EN 62368-1.

MCU W-3 cradle – switching on and off

The MCU W-3 cradle key is designed to control the use of the MCU W-3 joystick, i.e. to activate or deactivate it when needed.

MCU W-3 joystick activation and deactivation

To activate the joystick the operator has to insert the key as shown in the picture and turn it from OFF to ON. These positions are clearly indicated on the MCU W-3 cradle.

The operator can disable the joystick by switching the key to OFF and removing the key from the cradle. This prevents the CMM machine from being moved via the joystick.

The key is only removable when it is in the OFF position, which is confirmed by a key symbol displayed on the MCU W-3 screen.

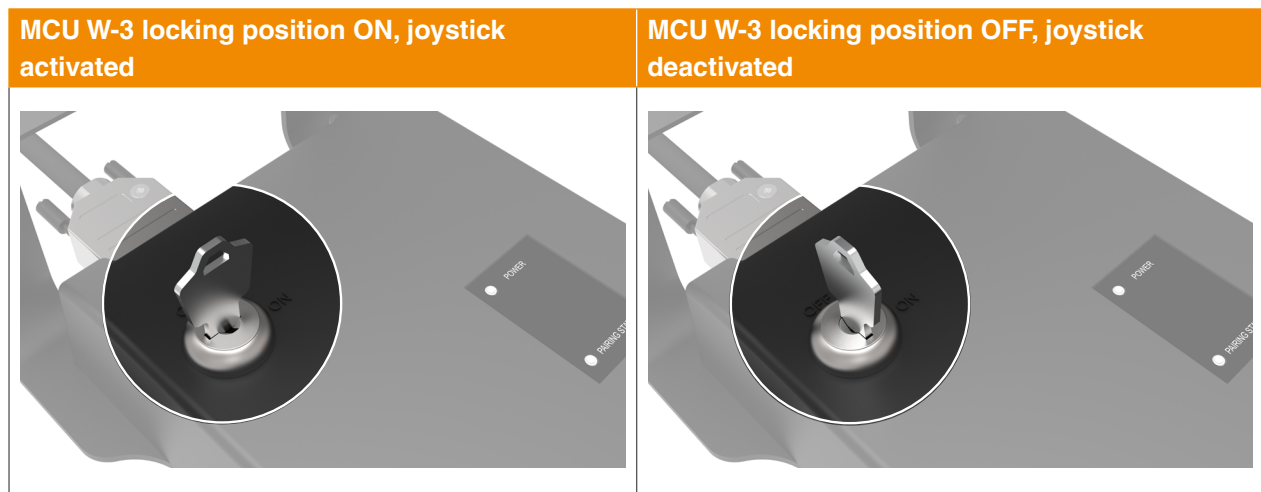

Pairing the MCU W-3 joystick with the cradle

The MCU W-3 is supplied pre-paired and this procedure is only required if part of the system is replaced.

Prior to pairing the MCU W-3 cradle to the joystick please ensure that:

- The MCU W-3 cradle power cable is unplugged.
- The battery in the MCU W-3 joystick has been removed.

NOTE: Do not put more than one MCU W-3 into pairing mode simultaneously.

To pair the MCU W-3 joystick to the cradle please do the following:

1. Plug-in power to the cradle.
2. Wait five seconds for the cradle to power up and the LED start-up sequence to complete.
3. Push and hold the cradle reset button until the pairing status LED rapidly flashes blue. This typically takes three seconds.

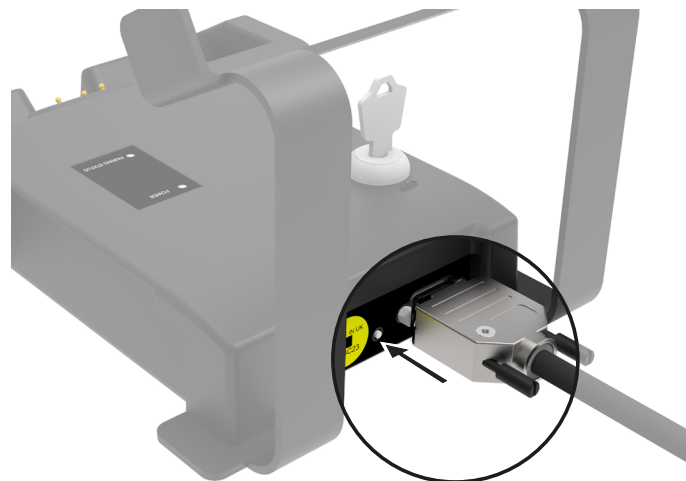

4. Wait for the pairing to fail, indicated by the pairing status LED turning solid red. This typically takes one minute.
5. Remove the cradle power and wait for the LEDs to turn off.
6. Replace power to the cradle.
7. Wait for the pairing cradle LED to turn RED, then press and hold the cradle reset button until the pairing status LED flashes blue.

8. Push and hold the mode selection button, insert the battery and place onto the cradle to power the joystick. The link sequence is started once you see)))) on the LCD screen – stop holding down the mode selection button.



9. Pairing is successful once the pairing status LED is solid blue.
10. If unsuccessful, the cradle will timeout after two minutes and the pairing status will turn solid red. If this happens restart the complete procedure again.

The operating range of the MCU W-3 wireless communication

The wireless communication link operates up to a range of 25 m line-of-sight between the MCU W-3 joystick and the cradle. Non line-of-sight range is dependent on the number and type of obstructions.

Use of the ID labels

MCU W-3 labels should be used to match the joystick with its paired MCU W-3 cradle. They are intended to avoid confusion if multiple MCU W-3 systems are operating in the same area. Ensure that the ID labels are stuck to both the MCU W-3 joystick and cradle. Ensure that the ID labels are updated if an MCU W-3 joystick is paired with a new cradle.



MCU W-3 cradle LED indicators

There are two LEDs on the MCU W-3 cradle.

The specification for the MCU W-3 LEDs is as follows:

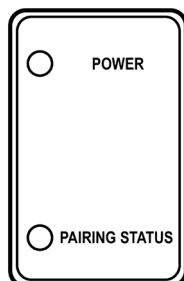

Power LED

LED status	Interpretation
Not lit	No power.
Amber	Power, but the key-switch is in the OFF position, meaning the joystick is locked and deactivated.
Green	Power, and the key-switch is in the ON position, meaning the joystick is unlocked and activated.

Pairing status LED

LED status	Interpretation
Red	Cradle has not been paired with a joystick.
Slow* flashing blue	Partner joystick is out of range, not switched on or pairing lost.
Fast* flashing blue	Pairing with joystick.
Blue	Normal operation (connected to joystick).

Any other combinations of colours or flashing patterns are classified as an error.

* **NOTE:** A slow flash is twice per second, fast is five times per second.

MCU W-3 battery operation

The MCU W-3 system is supplied with two batteries. One battery should be placed in the joystick and the spare one should be kept in the charger provided. The battery in the joystick is automatically recharged when it is replaced on the cradle so it should be returned whenever the joystick is not in use.

MCU W-3 first usage

Before using the MCU W-3 for the first time please check the batteries for damage or leakage. If damage or leakage is found do not use the battery. The batteries are shipped 30% charged and can be used immediately, but it is recommended to fully charge the batteries.

Fit the battery into the unit and place on the cradle to initiate.

The battery charge status is confirmed in the screen display.

When the battery charge status is low, which is indicated in the screen display and an audible beep, replace it with the spare battery from the charger.

1. Press in the clip on the right-hand side of the battery cover and lift to remove.



2. Pull the ribbon tab, placed under battery, to release and lift the battery.



3. Insert a new battery, with the negative terminal on the left (adjacent to the print) and positive terminal on the right.

NOTE: Ensure the ribbon is underneath the battery.



4. Press the battery down to ensure it is correctly situated.



5. Replace the battery cover by inserting the left side first then click the clip into place.



6. Place the MCU W-3 joystick on to the cradle to switch on.



Charging

A new, fully charged battery powers the MCU W-3 for at least 8 hours under normal usage conditions. Elevated temperatures will reduce battery life. If audible beeps are heard from the joystick, it means the battery power is running low. The joystick battery should be exchanged with the one from the charger or alternatively, replace the joystick on the cradle for recharging.

NOTE: If the joystick has been left off the cradle for a long period of time and the screen is blank, replace/exchange the battery.

Safety related to the MCU W-3 battery usage

Please refer to the appropriate section of the MCU W-3 safety information.

Appendix 1 – Saleable countries

Countries MCU W-3 can be sold into:

- Australia
- Austria
- Belgium
- Brazil
- Canada
- China
- Czech Republic
- Finland
- France
- Germany
- Hong Kong
- Hungary
- India
- Israel
- Italy
- Japan
- Netherlands
- Norway
- Poland
- Romania
- Singapore
- South Korea
- Spain
- Sweden
- Switzerland
- Taiwan
- Thailand
- Turkey
- UK
- USA
- Vietnam

NOTE: Refer to the **MCU W-3 webpage** to check the most up-to-date list of saleable countries.

www.renishaw.com/contact



#renishaw

 **+44 (0) 1453 524524**

 **uk@renishaw.com**

© 2026 Renishaw plc. All rights reserved. This document may not be copied or reproduced in whole or in part, or transferred to any other media or language by any means, without the prior written permission of Renishaw.

RENISHAW® and the probe symbol are registered trade marks of Renishaw plc. Renishaw product names, designations and the mark 'apply innovation' are trade marks of Renishaw plc or its subsidiaries. Other brand, product or company names are trade marks of their respective owners.

WHILE CONSIDERABLE EFFORT WAS MADE TO VERIFY THE ACCURACY OF THIS DOCUMENT AT PUBLICATION, ALL WARRANTIES, CONDITIONS, REPRESENTATIONS AND LIABILITY, HOWSOEVER ARISING, ARE EXCLUDED TO THE EXTENT PERMITTED BY LAW. RENISHAW RESERVES THE RIGHT TO MAKE CHANGES TO THIS DOCUMENT AND TO THE EQUIPMENT, AND/OR SOFTWARE AND THE SPECIFICATION DESCRIBED HEREIN WITHOUT OBLIGATION TO PROVIDE NOTICE OF SUCH CHANGES.

Renishaw plc. Registered in England and Wales. Company no: 1106260. Registered office: New Mills, Wotton-under-Edge, Glos, GL12 8JR, UK.

Part no.: H-1000-5496-03-A

Issued: 06.2026