

## RTP1 installation and user's guide

[www.renishaw.com](http://www.renishaw.com)

# RTP1 installation and user's guide

Document part number H-1000-5406-01-C



## RTP1 installation and user's guide

www.renishaw.com

# RTP1 general information

© 2024 - 2026 Renishaw plc. All rights reserved.



This document may not be copied or reproduced in whole or in part, or transferred to any other media or language by any means, without the prior written permission of Renishaw.

## Disclaimer

WHILE CONSIDERABLE EFFORT WAS MADE TO VERIFY THE ACCURACY OF THIS DOCUMENT AT PUBLICATION, ALL WARRANTIES, CONDITIONS, REPRESENTATIONS AND LIABILITY, HOWSOEVER ARISING, ARE EXCLUDED TO THE EXTENT PERMITTED BY LAW.

RENISHAW RESERVES THE RIGHT TO MAKE CHANGES TO THIS DOCUMENT AND TO THE EQUIPMENT, AND/OR SOFTWARE AND THE SPECIFICATION DESCRIBED HEREIN WITHOUT OBLIGATION TO PROVIDE NOTICE OF SUCH CHANGES.

## Trade marks

RENISHAW®, the probe symbol and REVO® are registered trade marks of Renishaw plc.

Renishaw product names, designations and the mark 'apply innovation' are trade marks of Renishaw plc or its subsidiaries.

Other brand, product or company names are trade marks of their respective owners.

## WEEE



The use of this symbol on Renishaw products and / or accompanying documentation indicates that the product should not be mixed with general household waste upon disposal. It is the responsibility of the end user to dispose of this product at a designated collection point for waste electrical and electronic equipment (WEEE) to enable reuse or recycling. Correct disposal of this product will help to save valuable resources and prevent potential negative effects on the environment. For more information, please contact your local waste disposal service or Renishaw distributor.

## Warranty

Unless you and Renishaw have agreed and signed a separate written agreement, the equipment and/or software are sold subject to the Renishaw Standard Terms and Conditions supplied with such equipment and/or software, or available on request from your local Renishaw office.

Renishaw warrants its equipment and software for a limited period (as set out in the Standard Terms and Conditions), provided that they are installed and used exactly as defined in associated Renishaw documentation. You should consult these Standard Terms and Conditions to find out the full details of your warranty.

Equipment and/or software purchased by you from a third-party supplier is subject to separate terms and conditions supplied with such equipment and/or software. You should contact your third-party supplier for details.

## RTP1 installation and user's guide

www.renishaw.com

### Care of equipment

Renishaw probes and associated systems are precision tools used for obtaining precise measurements and must therefore be treated with care.

### Changes to Renishaw products

Renishaw reserves the right to improve, change or modify its hardware or software without incurring any obligations to make changes to Renishaw equipment previously sold.

### Company registration details

Renishaw plc. Registered in England and Wales. Company no: 1106260. Registered office: New Mills, Wotton-under-Edge, Gloucestershire, GL12 8JR, UK.

### Packaging

To aid end user recycling and disposal the materials used in the different components of the packaging are stated here:

Packaging component	Material	94/62/EC code	94/62/EC number
Outer box	Corrugated fibreboard	PAP	20
Packaging insert	Corrugated fibreboard	PAP	20



**CAUTION:** If it is necessary to return any part of the system please ensure it is packaged carefully. Failure to do so could result in transit damage for which the customer would be liable. Products supplied in plastic boxes must be returned in the original packaging.

## RTP1 installation and user's guide

www.renishaw.com

### Patents

Features of the RTP1 system and associated products (such as REVO-2), equipment and techniques are the subjects of one or more of the following patents and patent applications:

CN101166951	EP1877727	IN405412	JP5196356	US10260856
CN101166953	EP1877732	IN446044	JP5350216	US10627259
CN101405563	EP1989504		JP5425476	US11402201
CN101405564	EP2002206		JP5653581	US7533574
CN101490430	EP2002207		JP5658863	US7809523
CN101772690	EP2035719		JP5706158	US7861430
CN102305613	EP2140318		JP5851969	US7885777
CN102906533	EP2149039		JP6013533	US8006398
CN103842766	EP2167911		JP6199870	US8186882
CN105408723	EP2431707		JP6348577	US8302321
CN105793695	EP2564151		JP7042620	US8425119
CN107532930	EP2764324		JP7105769	US8474148
CN109964098	EP3004797		JP7246127	US8511898
	EP3052926			US8517602
	EP3289314			US8601701
	EP3542130			US8756973
				US8978261
				US9038282
				US9366519
				US9903713

## RTP1 installation and user's guide

[www.renishaw.com](http://www.renishaw.com)

# RTP1 product compliance

## EU declaration of conformity

Contact Renishaw plc or visit [www.renishaw.com/EUCMM](http://www.renishaw.com/EUCMM) for the full EU declaration.

---

## UK declaration of conformity

Contact Renishaw plc or visit [www.renishaw.com/UKCMM](http://www.renishaw.com/UKCMM) for the full UK declaration.

---

## EMC conformity

This equipment must be installed and used in accordance with this installation guide. This product is intended for industrial use only and should not be used in a residential area or connected to a low voltage power supply network which supplies buildings used for residential purposes.

---

## FCC (USA only)

### Information to user (47 CFR 15.105)

This equipment has been tested and found to comply with the limits for a Class A digital device, pursuant to Part 15 of the FCC rules. These limits are designed to provide reasonable protection against harmful interference when the equipment is operated in a commercial environment. This equipment generates, uses, and can radiate radio frequency energy and, if not installed and used in accordance with the instruction manual, may cause harmful interference to radio communications. Operation of this equipment in a residential area is likely to cause harmful interference, in which case you will be required to correct the interference at your own expense.

### Information to user (47 CFR 15.21)

The user is cautioned that any changes or modifications not expressly approved by Renishaw plc or authorised representative could void the user's authority to operate the equipment.

### Equipment label (47 CFR 15.19)

This device complies with part 15 of the FCC Rules. Operation is subject to the following two conditions:

1. This device may not cause harmful interference.
  2. This device must accept any interference received, including interference that may cause undesired operation.
-

## RTP1 installation and user's guide

[www.renishaw.com](http://www.renishaw.com)

### ICES-001 (Canada only)

This ISM device complies with Canadian ICES-001(A) / NMB-001(A).

Cet appareil ISM est conforme à la norme ICES-001(A) / NMB-001(A) du Canada.

---

### REACH regulation

Information required by Article 33(1) of Regulation (EC) No. 1907/2006 ("REACH") relating to products containing substances of very high concern (SVHCs) is available at:

[www.renishaw.com/REACH](http://www.renishaw.com/REACH)

---

### China RoHS

Contact Renishaw plc or visit [www.renishaw.com/ChinaRoHSCMM](http://www.renishaw.com/ChinaRoHSCMM) for the full China RoHS tabulation.



## RTP1 installation and user's guide

[www.renishaw.com](http://www.renishaw.com)

# RTP1 safety

**CAUTION:** Before unpacking and installing the REVO-2 system and accompanying probes, the user should carefully read the safety instructions below and ensure that they are followed at all times by all operators.

The RTP1 is only to be used with the Renishaw REVO-2 head.



Operators must be trained in the use and application of the REVO-2 system and accompanying products, in the context of the machine it is fitted to, before being allowed to operate that machine.

Permanent magnets are used in some components of the REVO-2 system and associated products. It is important to keep them away from items which may be affected by magnetic fields, e.g. data storage systems, pacemakers and watches etc.

## RTP1 installation and user's guide

www.renishaw.com

# RTP1 warnings



Beware of unexpected movement. The user should remain outside of the full working envelope of probe head and stylus. The machine supplier should ensure the user is aware of the full working envelope of the system.

In all applications involving the use of machine tools or CMMs, eye protection is recommended.

It is the machine supplier's responsibility to ensure that the user is made aware of any hazards involved in operation, including those mentioned in Renishaw product documentation, and to ensure that adequate guards and safety interlocks are provided.

Refer to the machine supplier's operating instructions.

The system components contain no user serviceable parts, with the exception of FCR25. No attempt should be made to disassemble any part of the product. In the event of a problem please contact your supplier for assistance.

Under certain circumstances the probe signal may falsely indicate a probe-seated condition. Do not rely on probe signals to stop machine movement.

Probe trigger override on the MCU joystick should be used with care, since it will prevent the CMM from stopping in the event of a collision. The probe joints are designed to release the probe and / or the stylus holder in the event of a crash.

This equipment is not suitable for use in a potentially explosive atmosphere.

Pinch hazards exist between parts. Do not hold the probe or probe head during movements. It is essential for continued safety that all fuses are replaced by the correct type and rating. REVO must be transported in Renishaw supplied packaging.

The cables must meet Renishaw specifications. Incorrect cabling could cause damage to the equipment.



**WARNING:** Avoid touching the probes (including counter balance arms), stylus holders and other modules when the REVO-2 head is engaged (servo LED green) and the system is ready for measurement.

## RTP1 installation and user's guide

www.renishaw.com

- Remove protective caps prior to use:



- Avoid dropping the RTP1 or colliding with workpieces or parts of the CMM structure
- Particular care should be given to the two ends of the probe (the mating face to the REVO head and the temperature sensor)
- Ensure measurement surfaces are dry and clear of debris before being inspected with RTP1

### RTP1 handling

The RTP1 is a sensitive measuring device and should be handled with care.

## RTP1 installation and user's guide

[www.renishaw.com](http://www.renishaw.com)

# RTP1 references and associated documents

The following Renishaw documents are referred to in this document or may be a source of further relevant information. They can easily be acquired from Renishaw web site [www.renishaw.com](http://www.renishaw.com).

User guide: REVO-2 (H-1000-7590)  
Installation & user's guide: RSP3 (H-1000-5124)  
Installation & user's guide: SFP2 (H-1000-5365)  
User guide: RVP (H-1000-3322)  
Installation & user's guide: RUP1 (H-1000-5396)  
Installation & user's guide: RTP1 (H-1000-5406)  
Installation guide: UCC S5 REVO-2 CMM controller (H-1000-7598)  
Installation guide: SPA3-2 (H-1000-5364)  
Installation & user's guide: MCUlite-2 and MCU5-2 (H-1000-5280)  
Installation & user's guide: MCU W-3 (H-1000-5496)  
Installation & user's guide: MRS (H-1000-5088)  
Installation guide: MRS2 (H-1000-5255)  
Installation guide: REVO-2 change system port spacing guide (H-1000-5408)  
Technical specifications: Styli and accessories (H-1000-3200)

## RTP1 installation and user's guide

[www.renishaw.com](http://www.renishaw.com)

# RTP1 system description

The RTP1 probe brings automated temperature measurement to CMMs as part of the REVO 5-axis multi-sensor measuring system.

The RTP1 has had its temperature profile factory verified and each unit contains a preload mechanism with overtravel detection.

No specific analysis software is required, please contact your application software provider to check the RTP1 is supported.

Because the RTP1 system is used as part of a multi-sensor system, and uses specially designed calibration routines, the location of the tip is known precisely. Temperature data can therefore be collected from a specific location, even if there is significant variation between nominally identical parts. The temperature can then be stored alongside the part's dimensional data for future reference.

## System components overview

### RTP1 probe



The RTP1 probe houses electronics to condition the signals from the transducer so that they can be communicated to the controller via the REVO-2 head. RTP1 can be stored in the RCP TC-2 port on the MRS or MRS2 racks.

## RTP1 installation and user's guide

[www.renishaw.com](http://www.renishaw.com)

### RCP TC-2



The thermally controlled RCP TC-2 port maintains its stored probe at operating temperature. It is compatible with Renishaw's MRS and MRS2 rack systems. It should be used for the RTP1 probe.

## RTP1 installation and user's guide

www.renishaw.com

# RTP1 specifications

## Specification

Force on part	0.47 N
Mounting	Magnetised kinematic coupling
Probe head	REVO-2 only
Rack port compatibility	RCP TC-2
Change rack	MRS2 recommended
Software compatibility	UCCsuite 5.9 or later
Weight	0.11 kg
25 °C temperature accuracy *	± 0.5 °C
Operating temperature range	+10 °C to +40 °C (+50 °F to +104 °F)
Storage temperature range	-25 °C to +70 °C (-13 °F to +158 °F)
Typical temperature measurement time	<10 seconds
Operating humidity	0% to 80% (non-condensing)
Storage humidity	0% to 80% (non-condensing)

\* Valid for surfaces where the roughness is better than 3.2 µm Ra.



**NOTE:** Cannot be used for dynamic temperature compensation.

# RTP1 installation and user's guide

www.renishaw.com

## RTP1 dimensions

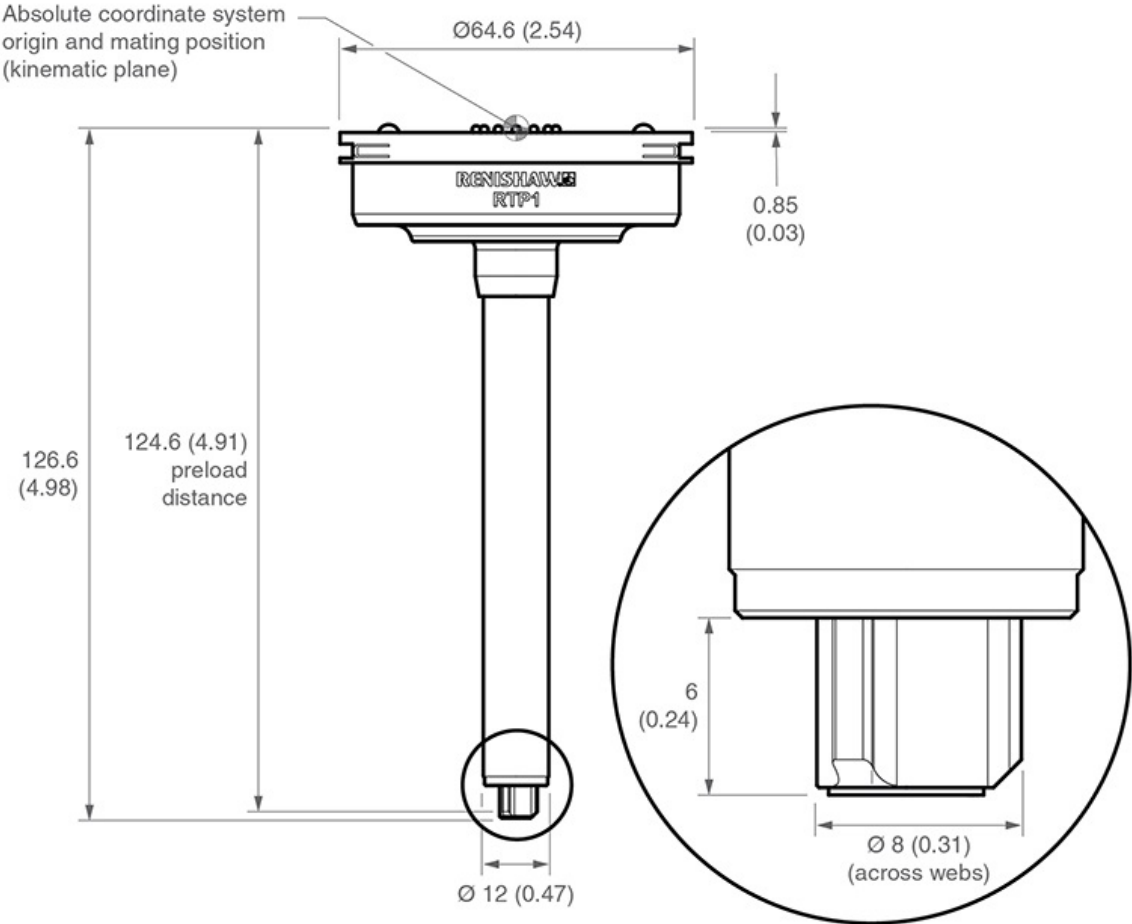

**i** NOTE: Dimensions are shown in mm (in).

**i** NOTE: Dimensions to kinematic mounting plate.

## RTP1 installation and user's guide

www.renishaw.com

# Manually mounting / removing the RTP1 from REVO-2

To manually mount or remove the probe from the REVO head you need to:

1. Align the front of the head with the probe (look at the "Renishaw" engraving on the front of probe or alignment marks as applicable).
2. Carefully align the probe to the head, allowing the magnetic attraction to gently connect the kinematic joints.
3. Gently rotate the probe to ensure correct location.
4. To remove, securely hold the probe and gently tilt to break the kinematic joints.



**WARNING:** Avoid touching the probe and other modules when the REVO-2 head LEDs are both green and the head is ready for measurement. Green LEDs indicate that the head is engaged and the controller has a valid probe calibration.

# RTP1 calibration

Calibration of the RTP1 probe's temperature measurement capability is performed at the factory and should never require repeating.

## RTP1 installation and user's guide

www.renishaw.com

# RTP1 probe change system

The REVO-2 probe change system is designed to allow automatic REVO-2 probe and accessory changing on a CMM. For optimum metrology, RTP1 probes should be changed automatically using the RCP TC-2 change ports. These ports are mounted on the modular rack system (MRS or MRS2).

## RCP TC-2

The RCP TC-2 is a thermally controlled port for storing REVO probes whilst not in use.

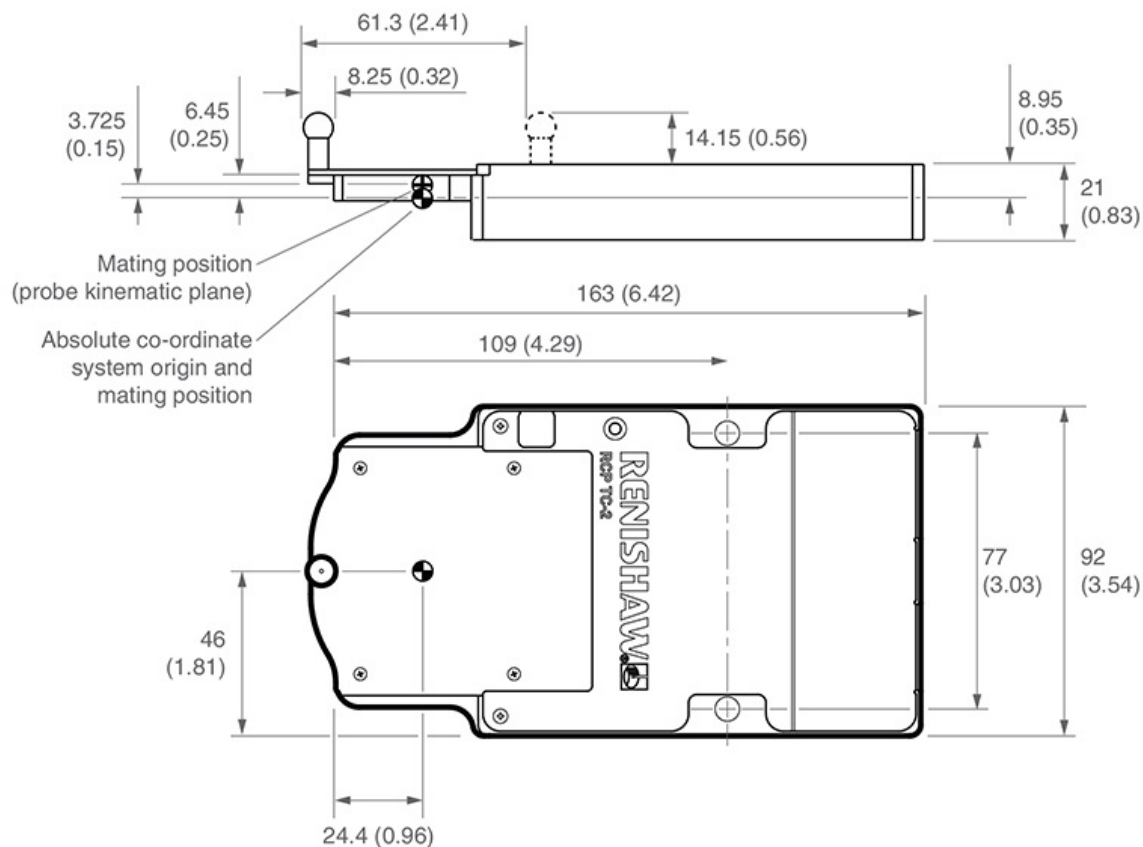

**NOTE:** Dimensions are shown in mm (in).

Key features of the RCP TC-2:

- Maintains the probe at the operating temperature when not in use, for optimum metrology
- Mounts on the MRS or MRS2 to allow multi-port systems to be created

# Put down and pick up routines for RCP TC-2

The following routines are handled through UCCserver for RCP TC-2:

- Alignment routine
- Put down and pick up
- Routine safe position

## RTP1 installation and user's guide

www.renishaw.com

# Connecting RCP TC-2 to PSU

Using a PSU other than the one supplied by Renishaw is not recommended.

DC extension cables are available for the PSU but the length should not exceed 15 m otherwise the performance can be affected.

It is possible to power up to four RCP TC-2 ports with one PSU using the daisy-chain technique shown below. RCP TC-2 ports can be arranged in any sequence on a rail.

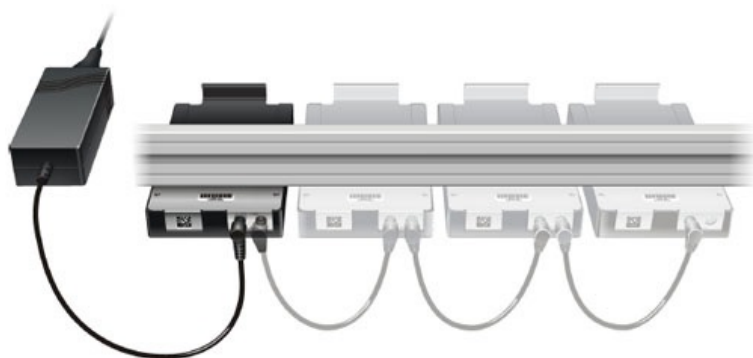

**NOTE:** Nothing other than RCP TC-# should be connected to the PSU. No more than four RCP TC-# units can be powered from one PSU. No more than one PSU should be connected to a daisy chain of ports. RCP TC-#s need to be next to each other on the MRS2 rail for daisy chaining. Power can be connected to either end of the daisy chain. Turn off or disconnect the mains supply to the PSU before fitting dc power cables to the ports.

## Spares

Part description	Renishaw part number
DC daisy-chain cable	P-CA82-0019
DC extension cable (1.5 m)	A-3060-0016
RCP TC-# PSU	P-EA02-0021
DC extension cable (5 m)	A-3060-0017
DC extension cable (10 m)	A-3060-0018

## RTP1 installation and user's guide

www.renishaw.com

# RCP TC-2 switch settings

The temperature can be set using the rotary switch on the rear of the RCP TC-2:



## RCP TC-2 switch settings

Position	Description
0 - 3	Reserved for future use
4 (factory set)	Suitable for specified system ambient temperature
5 - 9	Reserved for future use

**i** **NOTE:** Please do not change the settings without contacting your supplier.

**!** **CAUTION:** This unit is not sealed. Please do not insert anything into the gaps under the port lid as it can cause damage to internal components within the product.

## RTP1 installation and user's guide

www.renishaw.com

# RCP TC-2 LED status indication and troubleshooting

LED	Status	Troubleshooting
Green	Power on, probe present, temperature within target	n/a
Flashing green	Power on, probe present, temperature outside of target	Wait for the rack to reach stable temperature.
Amber	Power on, probe not present, temperature within target	If the probe is present, clean the port and probe contacts.
Flashing amber	Power on, probe not present, temperature outside of target	If the probe is present, clean the port and probe contacts. Wait for the rack to reach stable temperature.
Flashing red	Error	Cycle power to restart. If the problem persists, contact your supplier.



**WARNING:** The RCP TC-2 plate may be hot.

RCP TC plate



## RTP1 installation and user's guide

www.renishaw.com

# Cleaning the RTP1 system

**CAUTION:** Always refer to the 'Safety' and 'Warnings' sections of this guide. Failure to do so could lead to personal injury.

Following the simple procedures given below will prolong the operational life and maintain the high performance of the system. The user should determine the frequency of inspection and maintenance actions according to the conditions of use.

All system components should be cleaned using a soft, lint free cloth and must be kept dry.

## Kinematic couplings

The kinematic coupling mechanisms incorporated throughout the system have precision ball seating and permanent magnets. It is recommended that all these features be cleaned before first use, and thereafter at regular intervals.

A cleaning kit for the precision ball seating and permanent magnet is available from your Renishaw supplier (part number A-1085-0016). It comprises strips of 'yellow tack' material. Use the yellow tack to clean the areas indicated with arrows on the image below.



With clean hands, tear off a small piece, shape into a small ball and press into / onto each of the features in turn, rotating to a fresh piece of material as you work around.

**CAUTION:** Ensure no yellow tack debris is left on the surface. The yellow tack should not be used for electrical contacts.

## RTP1 installation and user's guide

[www.renishaw.com](http://www.renishaw.com)

### Electrical contacts

The electrical contacts, indicated with arrows in the image below, should be carefully cleaned with an alcohol-based cleaner (e.g. IPA) and a lint-free cloth.



The frequency of cleaning depends on the local environment conditions, but should be at least every 500 changes.

## RTP1 care and maintenance

The RTP1 probes are sensitive measuring devices and should be handled with care:

- Avoid dropping the RTP1 probe or colliding with workpieces or parts of the CMM structure
- Particular care should be given to probe end. Avoid contact with the end,
- Visually examine the stylus tip for accumulation of dirt or dust
- Ensure measurement surfaces are dry and clear of debris before being inspected with the RTP1 probe

If the probe is suspected of giving poor performance, or if it has been used on unclean surfaces:

- Gently wipe the end with a lint free cloth dampened with clean alcohol to remove any debris

## Rack port maintenance



**CAUTION:** Always refer to the 'Safety' and 'Warnings' sections of this guide. Failure to do so could lead to personal injury.

Periodic cleaning of the ports, lids and outer surfaces using a soft, lint free cloth is recommended to prevent contamination of stored probes and modules.

**Renishaw plc**  
New Mills, Wotton-under-Edge  
Gloucestershire, GL12 8JR  
United Kingdom

**T** +44 (0)1453 524524  
**F** +44 (0)1453 524901  
[www.renishaw.com/cmmsupport](http://www.renishaw.com/cmmsupport)



**For worldwide contact details,  
please visit our main website at  
[www.renishaw.com/contact](http://www.renishaw.com/contact)**