

SPA3-2 installation guide

www.renishaw.com

SPA3-2 installation guide

Documentation part number: H-1000-5364-06-B



SPA3-2 installation guide

www.renishaw.com

SPA3-2 general information

© 2018 - 2026 Renishaw plc. All rights reserved.

 ORIGINAL LANGUAGE VERSION

This document may not be copied or reproduced in whole or in part, or transferred to any other media or language by any means, without the prior written permission of Renishaw.

Disclaimer

WHILE CONSIDERABLE EFFORT WAS MADE TO VERIFY THE ACCURACY OF THIS DOCUMENT AT PUBLICATION, ALL WARRANTIES, CONDITIONS, REPRESENTATIONS AND LIABILITY, HOWSOEVER ARISING, ARE EXCLUDED TO THE EXTENT PERMITTED BY LAW.

RENISHAW RESERVES THE RIGHT TO MAKE CHANGES TO THIS DOCUMENT AND TO THE EQUIPMENT, AND/OR SOFTWARE AND THE SPECIFICATION DESCRIBED HEREIN WITHOUT OBLIGATION TO PROVIDE NOTICE OF SUCH CHANGES.

Trade marks

RENISHAW[®], the probe symbol and REVO[®] are registered trade marks of Renishaw plc.

Renishaw product names, designations and the mark 'apply innovation' are trade marks of Renishaw plc or its subsidiaries.

Other brand, product or company names are trade marks of their respective owners.

WEEE



The use of this symbol on Renishaw products and / or accompanying documentation indicates that the product should not be mixed with general household waste upon disposal. It is the responsibility of the end user to dispose of this product at a designated collection point for waste electrical and electronic equipment (WEEE) to enable reuse or recycling. Correct disposal of this product will help to save valuable resources and prevent potential negative effects on the environment. For more information, please contact your local waste disposal service or Renishaw distributor.

Warranty

Unless you and Renishaw have agreed and signed a separate written agreement, the equipment and/or software are sold subject to the Renishaw Standard Terms and Conditions supplied with such equipment and/or software, or available on request from your local Renishaw office.

Renishaw warrants its equipment and software for a limited period (as set out in the Standard Terms and Conditions), provided that they are installed and used exactly as defined in associated Renishaw documentation. You should consult these Standard Terms and Conditions to find out the full details of your warranty.

Equipment and/or software purchased by you from a third-party supplier is subject to separate terms and conditions supplied with such equipment and/or software. You should contact your third-party supplier for details.

SPA3-2 installation guide

www.renishaw.com

Care of equipment

Renishaw probes and associated systems are precision tools used for obtaining precise measurements and must therefore be treated with care.

Changes to Renishaw products

Renishaw reserves the right to improve, change or modify its hardware or software without incurring any obligations to make changes to Renishaw equipment previously sold.

Company registration details

Renishaw plc. Registered in England and Wales. Company no: 1106260. Registered office: New Mills, Wotton-under-Edge, Gloucestershire, GL12 8JR, UK.

Packaging

To aid end user recycling and disposal the materials used in the different components of the packaging are stated here:

Packaging component	Material	94/62/EC code	94/62/EC number
Outer box	Cardboard - 70% recycled content	PAP	20
Packing foam	Polyurethane	PU	7
Packing foam	Cross-linked polyethylene	LDPE	4
Plastic bags	Low density polyethylene bag	LDPE	4

SPA3-2 installation guide

www.renishaw.com

SPA3-2 product compliance

EU declaration of conformity

Contact Renishaw plc or visit www.renishaw.com/EUCMM for the full EU declaration.

UK declaration of conformity

Contact Renishaw plc or visit www.renishaw.com/UKCMM for the full UK declaration.

EMC conformity

This equipment must be installed and used in accordance with this installation guide. This product is intended for industrial use only and should not be used in a residential area or connected to a low voltage power supply network which supplies buildings used for residential purposes.

FCC (USA only)

Information to user (47 CFR 15.105)

This equipment has been tested and found to comply with the limits for a Class A digital device, pursuant to Part 15 of the FCC rules. These limits are designed to provide reasonable protection against harmful interference when the equipment is operated in a commercial environment. This equipment generates, uses, and can radiate radio frequency energy and, if not installed and used in accordance with the instruction manual, may cause harmful interference to radio communications. Operation of this equipment in a residential area is likely to cause harmful interference, in which case you will be required to correct the interference at your own expense.

Information to user (47 CFR 15.21)

The user is cautioned that any changes or modifications not expressly approved by Renishaw plc or authorised representative could void the user's authority to operate the equipment.

Equipment label (47 CFR 15.19)

This device complies with part 15 of the FCC Rules. Operation is subject to the following two conditions:

1. This device may not cause harmful interference.
 2. This device must accept any interference received, including interference that may cause undesired operation.
-

SPA3-2 installation guide

www.renishaw.com

ICES-001 (Canada only)

This ISM device complies with Canadian ICES-001(A) / NMB-001(A).

Cet appareil ISM est conforme à la norme ICES-001(A) / NMB-001(A) du Canada.

REACH regulation

Information required by Article 33(1) of Regulation (EC) No. 1907/2006 ("REACH") relating to products containing substances of very high concern (SVHCs) is available at:

www.renishaw.com/REACH

China RoHS

Contact Renishaw plc or visit www.renishaw.com/ChinaRoHSCMM for the full China RoHS tabulation.



NRTL certification

The SPA3-2 product has been independently tested to the relevant requirements of the following standards:

- UL 61010-1:2012/ R:2016-04
- CAN/CSA-C22.2 No. 61010-1:2012/U2:2016-04

The NRTL TÜV SÜD certification mark demonstrates compliance with these requirements.

SPA3-2 installation guide

www.renishaw.com

SPA3-2 safety

 Where this symbol is displayed on the product the user must refer to the installation guide for information and safety advice.

If the equipment is used in a manner not specified by the manufacturer then the safety of the equipment may be impaired.

 **WARNING:** The SPA3-2 must be earthed. Earthing provisions for the complete machine is the responsibility of the OEM or installer.

 **WARNING:** The SPA3-2 must not be powered directly from the mains. A single fault tolerant PSU approved to BS EN IEC 62368-1:2020+A11:2020 (or current version) must be used, and connected to a supply incorporating a protective earth conductor.

 **WARNING:** SPA3-2 is isolated from the power supply by disconnection of the ac power connector from the external PSU. If any additional means of isolation is required, it must be specified and fitted by the machine manufacturer or the installer of the product. The isolator must be sited within easy reach of the CMM operator and comply with BS EN 61010-1:2010 (or current version) and any applicable national wiring regulations for the country of installation.

 **WARNING:** Maintenance should only be carried out after the machine has been isolated from the electrical supply, compressed air supply or other energy sources in accordance with the machine manufacturer's instructions.

Machine safety

 **WARNING:** Switching off or isolating the SPA3-2 may NOT prevent unexpected machine movement. The user is advised to isolate the machine from the electricity supply, compressed air or other energy sources in accordance with the machine manufacturer's instructions before entering the danger zone or performing any maintenance operations.

 **CAUTION:** It is strongly recommended that the CMM manufacturer or retrofitter includes a periodic test of the emergency stop and if fitted, the associated reset switch in their maintenance instructions.

SPA3-2 installation guide

www.renishaw.com

SPA3-2 international safety instructions

BG - ПРЕДУПРЕЖДЕНИЕ

Моля, обърнете на приложение 1 и прочетете инструкциите за безопасност на вашия собствен език, преди за разопаковате и монтирате този продукт.

CS - VÝSTRAHA

Před rozbalením a instalací tohoto výrobku si přečtěte bezpečnostní pokyny ve vlastním jazyce uvedené v příloze 1.

DA - ADVARSEL

Læs sikkerhedsinstrukserne i Appendix 1 FØR udpakning og installation af dette produkt.

DE - WARNHINWEIS

Bevor Sie dieses Produkt auspacken und installieren, konsultieren Sie bitte Anhang 1 und lesen Sie die Sicherheitshinweise in Ihrer Sprache.

EL - ΠΡΟΕΙΔΟΠΟΙΗΣΗ

Γυρίστε στο Κεφάλαιο 1 και διαβάστε τις οδηγίες ασφαλείας στη δική σας γλώσσα προτού ανοίξετε αυτό το προϊόν για να το εγκαταστήσετε.

EN - WARNING

Before unpacking and installing this product, please consult Appendix 1 and read the safety instructions in your language.

ES - ADVERTENCIA

Consulte el apéndice 1 y lea las instrucciones de seguridad en su idioma antes de desempaquetar e instalar este producto.

ET - HOIATUS

Palun vaadake 1. lisa ning lugege enne selle toote lahtipakkimist ja paigaldamist ohutusjuhend läbi.

FI - VAROITUKSIA

Lue liitteessä 1 olevat omalla kielelläsi kirjoitetut turvaohjeet ennen tämän tuotteen pakkauksen avaamista ja asentamista.

FR - AVERTISSEMENT

Consulter l'annexe 1 et les instructions de sécurité dans votre propre langue avant de débiller et d'installer ce produit.

SPA3-2 installation guide

www.renishaw.com

GA - RABHADH

Téigh chuig aguisín 1 agus déan na treoracha sábháilteachta a léamh i do theanga féin le do thoil sula ndéantar an táirge seo a dhíphacáil agus a shuiteáil.

HR - NAPOMENA

Prije nego što proizvod izvadite iz ambalaže i ugradite ga, otvorite Prilog 1 i pročitajte sigurnosne upute na svom jeziku.

HU – FIGYELMEZTETÉS

A termék kicsomagolása és telepítése előtt olvassa el az 1. számú függelékben található, az Ön anyanyelvén hozzáférhető biztonsági utasításokat.

IT - AVVISO

Prima di aprire ed installare questo prodotto, leggere le istruzioni di sicurezza nella vostra lingua riportate nell'Appendice 1.

JA - 警告

この製品を箱から取り出し設置する前に、付録 1 に記載された安全性に関する注意書きをお読みください。

LT – ĮSPĖJIMAS

Prieš išpakuodami ir įdiegdami produktą, turite grįžti prie 1 priedo ir perskaityti nurodymus dėl saugos savo kalba.

LV – BRĪDINĀJUMS

Pirms šī izstrādājuma izsaiņošanas un uzstādīšanas izskatiet 1. pielikumā sniegtās drošības instrukcijas savā valodā.

MT - TWISSIJA

Jekk jogħġbok mur f'appendiċi 1 u aqra l-istruzzjonijiet tas-sigurtà fil-lingwa tiegħek qabel ma toħroġ dan il-prodott mill-ippakkjar u tinstallah.

NL - WAARSCHUWING

Ga naar appendix 1 en lees de veiligheidsinstructies in uw eigen taal, voordat u dit product uitpakt en installeert.

PL - OSTRZEŻENIE

Przed rozpakowaniem i zainstalowaniem tego produktu prosimy o zapoznanie się z Dodatkiem 1 i przeczytanie zaleceń dotyczących bezpieczeństwa w danym języku.

PT - ADVERTÊNCIA

Você deve retornar ao Anexo 1 e ler as instruções de segurança em seu idioma antes de desembalar e instalar este produto.

SPA3-2 installation guide

www.renishaw.com

RO - AVERTISMENT

Înainte de a desface ambalajul și a instala acest produs, vă rugăm să căutați Anexa 1 și să citiți cu atenție instrucțiunile de siguranță, în limba română.

SK - VÝSTRAHA

Pred rozbalením a inštaláciou tohto produktu si pozrite prílohu 1 a prečítajte si bezpečnostné pokyny vo vašom jazyku.

SL - OPOZORILO

Preden izdelek vzamete iz embalaže in ga vgradite, odprite Prilogo 1 in preberite varnostna navodila v svojem jeziku.

SV - VARNING

Gå till bilaga 1 och läs säkerhetsinstruktionerna på ditt eget språk innan du packar upp och installerar denna produkt.

ZH-TW - 警告

在拆開和安裝本產品之前，請翻頁至附錄 1 閱讀母語的安全指示。

ZH - 警告

在拆包和安裝本產品之前，請翻到附录1，阅读中文版安全说明。

SPA3-2 installation guide

www.renishaw.com

SPA3-2 environmental conditions

Indoor use	IP10* (BS EN60529:1992 (or current version))
Altitude	Up to 2000 m
Operating temperature	+5 °C to +50 °C
Storage temperature	-25 °C to +70 °C
Relative humidity	80% maximum (non-condensing) for temperatures up to +31 °C Linear decrease to 50% at +50 °C
Transient voltages	Overvoltage category I
Pollution degree	2
Voltage fluctuations	Refer to dc power specification



* **NOTE:** IP10 rating achieved with all connectors fitted. It may be necessary to house SPA3-2 in a suitable electrical enclosure according to the installation's environmental conditions to obtain a higher IP rating.

SPA3-2 installation guide

www.renishaw.com

SPA3-2 references and associated documents

The following Renishaw documents are referred to in this document or may be a source of further relevant information. They can easily be acquired from Renishaw website www.renishaw.com.

Installation guide: UCC T3 PLUS and UCC S3 CMM controller (H-1000-2118)

Installation guide: UCC T3-2 (H-1000-5254)

Installation guide: UCC T5 (H-1000-7573)

Installation guide: UCC S5 REVO-2 CMM controller (H-1000-7598)

Installation & user's guide: MCUlite-2 and MCU5-2 (H-1000-5280)

Installation & user's guide: MCU W-3 (H-1000-5496)

UCCassist-2 help	Found within UCCassist-2
------------------	--------------------------

External documents

National and international standards including the following may be applicable to the finished machine or installation:

- BS EN 60204-1:2018* (Safety of machinery - Electrical equipment of machines - Part 1: General requirements)
- BS EN 61010-1:2010* (Safety requirements for electrical equipment for measurement, control and laboratory use. General requirements)
- BS EN ISO 13849-1:2015* and BS EN ISO 13849-2:2012* (Safety of machinery. Safety-related parts of control systems)
- BS EN ISO 12100:2010* (Safety of machinery - General principles for design - Risk assessment and risk reduction)
- BS EN IEC 62368-1:2020+A11:2020* (Information technology equipment. Safety. General requirements)

It is the responsibility of the OEM or installer to ensure that the finished installation complies with applicable national regulations for the country of installation.

* Or current version.

SPA3-2 installation guide

www.renishaw.com

SPA3-2 introduction

The SPA3-2 is a 3-axis dc servo power amplifier and is a drop-in replacement for the SPA3. The SPA3-2 is compatible with the UCC controller range and the MCUIlite-2, MCU5-2 and MCU W-3 joysticks.

This system can operate on the majority of CMM structures without the requirement for changing motors.

Features

The SPA3-2 has the following improvements over the SPA3:

- The primary advantage of the SPA3-2 is the ample machine I/O: six inputs and seven outputs as well as six I/O ports which are configurable to be either inputs or outputs
- Adjustable power supply voltage to readheads and motor encoders
- Support for absolute BiSS readheads
- Support for up to four axes of position feedback for dual Y scale machines

Operating specification

- Three axis dc servo motor drive:
 - Independent axis voltage control of 12 V to 80 V
 - Independent axis current limits up to 9.5 A peak
 - Simulated linear power amplifier. Drive outputs are free from switching edges, eliminating noise from drive PWM, improving repeatability and reducing emissions
- Axis scale and motor encoder power supply: 5.25 V to 6.75 V, 0.5 A maximum (each)
- +24 V 1 A power supply for CMM solenoids, solid state switches, machine user specific hardware
- Digital input signals from air pressure, crash detection, all axis inner and outer travel limits and six user specific inputs
- Digital output signals to control machine air, axis brakes and seven user specific outputs
- Six configurable digital pins which can be independently configured to be either input or output

SPA3-2 installation guide

www.renishaw.com

Front panel



Rear panel

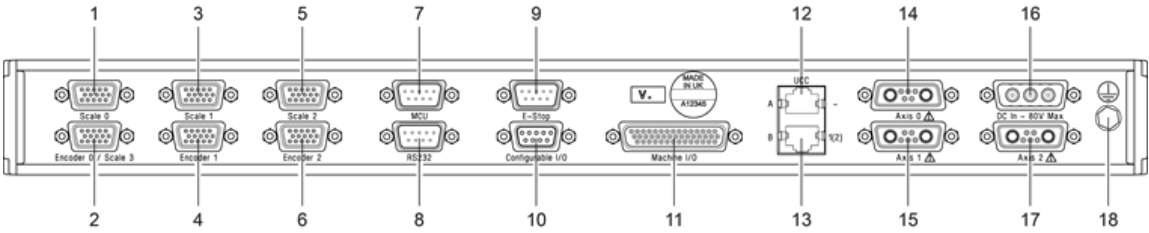

Key	Description	Key	Description
1	Scale 0 interface (15W HDD socket)	10	Configurable I/O (9W D socket)
2	Encoder 0 / Scale 3 interface (15W HDD socket)	11	Machine I/O (44W HDD socket)
3	Scale 1 interface (15W HDD socket)	12	UCC - A (RJ45 socket)
4	Encoder 1 interface (15W HDD socket)	13	UCC - B (RJ45 socket)
5	Scale 2 interface (15W HDD socket)	14	Axis 0 (7W2 D socket)
6	Encoder 2 interface (15W HDD socket)	15	Axis 1 (7W2 D socket)
7	MCU (9W D plug)	16	DC in - 80 V max (3W3 D plug)
8	RS232 (9W D plug)	17	Axis 2 (7W2 D socket)
9	E-STOP (9W D plug)	18	Protective conductor terminal (M5)

SPA3-2 installation guide

www.renishaw.com

SPA3-2 system components

The part numbers of the SPA3-2 kits and upgrades are:

Kit	Part number
SPA3-2 amplifier kit comprising of: RJ45 cable, bracket kit, power cable	A-6095-0200
SPA3-2 amplifier kit for 6-axis applications comprising of: RJ45 cable, bracket kit, power cable, 6-axis E-STOP cable	A-6095-0300

Accessories	Part number
PSU 600 W 48 V to 58 V (medium / large machines)	A-5518-0025
PSU 880 W 80 V (large machines)	A-6095-9529
Connector kit	A-5518-0010
Replacement filter kit	A-5518-0011
SPA3-2 6-axis emergency stop cable	A-5623-0095

SPA3-2 installation guide

www.renishaw.com

Installation software

UCCassist-2

The SPA3-2 is installed using the Renishaw UCCassist-2 program as part of the commissioning and maintenance process of a UCC controlled CMM.

Capabilities of the software include:

- Controller configuration for individual machine hardware
- Machine system diagnostics
- Operation with Renishaw's machine checking gauge, enabling the user to complete frequent volumetric accuracy tests to ensure the CMM is running within the specified operational tolerances
- Automated CMM error mapping routines, when used in conjunction with the Renishaw ML10, XM600 or XL80 laser systems
- Automated firmware update for all UCC and SPA products



CAUTION: Do not power down the SPA3-2 whilst parameters or firmware are being updated. This may cause an error requiring the unit to be returned to Renishaw.

Software installation

The new features of SPA3-2 are supported in UCCsuite 5.1 and later. The software can be obtained online at www.renishaw.com/cmmsupport or from your local Renishaw supplier. Follow the prompts to install the UCCserver software.



WARNING: The SPA3-2 must only be commissioned through Renishaw software. Failure to do so may result in unexpected machine movement.

SPA3-2 installation guide

www.renishaw.com

General wiring standards for the installation of the SPA3-2

To achieve reliable operation of the SPA3-2, the following should be observed:

- The system must be portable appliance tested (PAT) before the equipment is powered
- All signal cables must be screened and all cable screens should be connected electrically to the cable connector's metal shells
- It is recommended that screens for motor cables should be connected to the shell on the SPA3-2 end and connected to the motor housing at the CMM end
- Signal cables such as tacho and scale cables should be connected to the SPA3-2 and have a cable shield that runs to the machine but left unconnected at the machine
- All cable connectors should be secured to the SPA3-2 by the connector jack screws
- SPA3-2 has a maximum output voltage of 80 Vdc and peak current of 9.5 A per axis. The actual peak current will be dependent on the size of the motor fitted and the machine performance specification, therefore the cable size needs to be calculated by the system installer or OEM.

 **WARNING:** The installation should only be performed by Renishaw or a Renishaw certified installation engineer.

 **WARNING:** Hazardous voltage warning labels must be fitted to motors where hazardous voltages are present.

 **CAUTION:** Motor cables must have a minimum cross section of 0.3 mm².
 For SPA3-2 supply voltage of over 60 V, motor cables must have a minimum cross section of 0.75 mm² as specified in BS EN 60204-1:2018 para. 12.2 (or current version) and have insulation rated to at least 150 V to provide adequate protection against electric shock.
 The actual peak current will be dependent on the size of the motor fitted and the machine performance specification, therefore the cable size needs to be calculated by the system installer or OEM.

SPA3-2 installation guide

www.renishaw.com

SPA3-2 installation

Dimensions



i NOTE: Dimensions in mm (in).



The SPA3-2 unit draws air from the right hand side when viewed from the front and expels air out of the left hand side. A minimum clearance gap of 10 mm is necessary between the sides of the unit and any potential obstruction.

SPA3-2 installation guide

www.renishaw.com

Mounting the SPA3-2

The SPA3-2 is supplied with a rack mounting kit, this allows the SPA3-2 to be fitted into a standard 19" rack.

Fitting mounting brackets

i NOTE: The screws supplied with this kit are M5 × 6 mm countersink type.



SPA3-2 installation guide

www.renishaw.com

SPA3-2 system connection

This section details connection to all of the SPA3-2 ports.

Earth bonding scheme

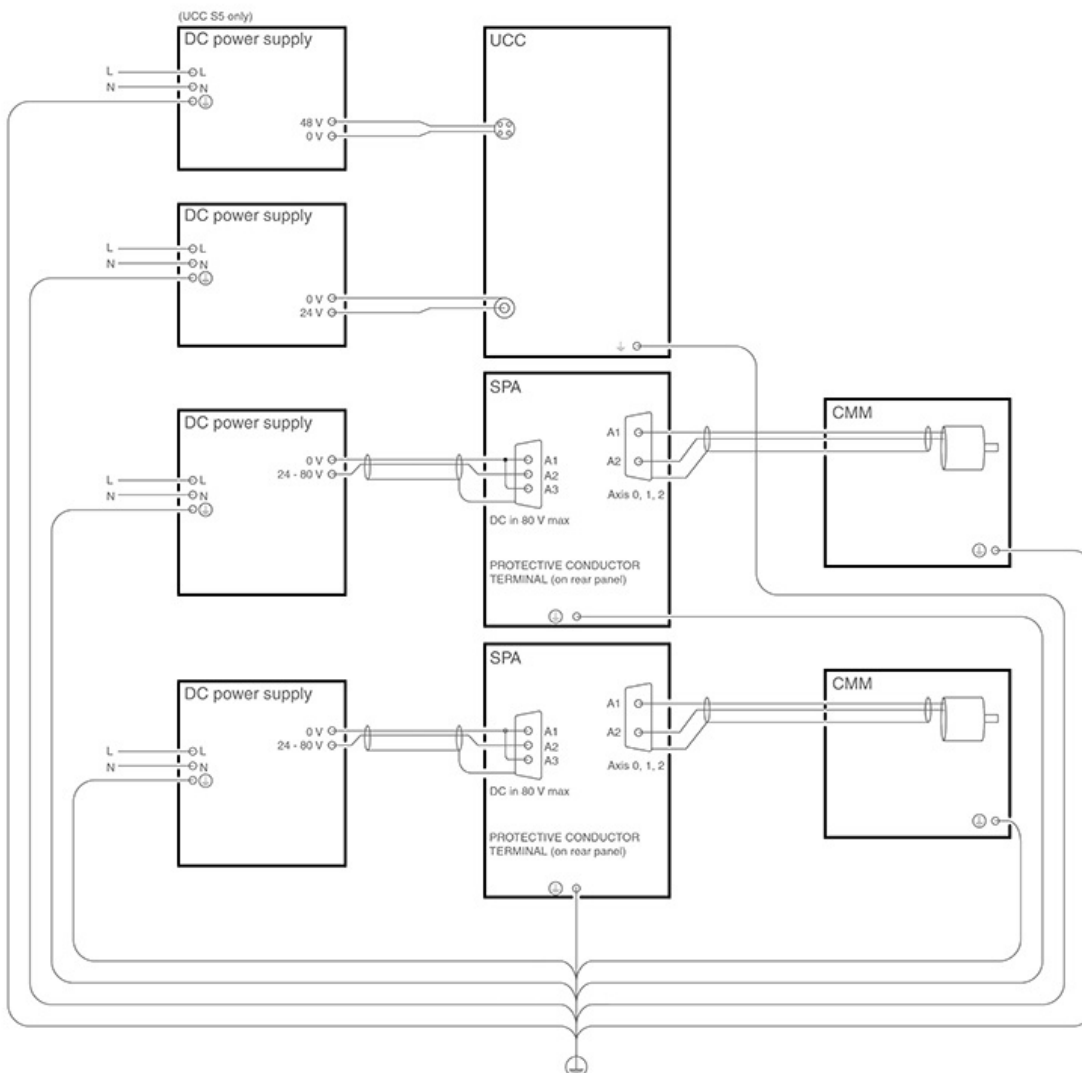

NOTE: All protective earth connections must be separately made to the incoming supply earth point.

NOTE: A ring pressure crimp must be used to terminate the protective conductor prior to being secured to the provided earth terminal.

SPA3-2 installation guide

www.renishaw.com

Scale and motor encoder inputs (15W HDD socket)

The SPA3-2 can support up to 4-axis scale inputs and 3-axis of motor encoder inputs. Each input supports a RS-422 (TIA/EIA-422) standard quadrature interface with an edge rate of up to 30 MHz, also supported are discrete and tristate error signals as well as readhead limit switches.

The scale inputs support absolute readheads using the BiSS protocol as used by Renishaw Resolute™, 18, 26, 32 and 36 bit protocols are supported.

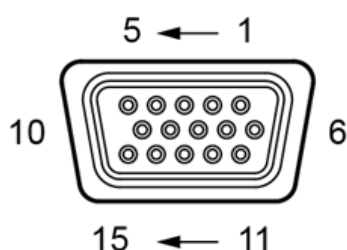

Pin number	Incremental readhead	Motor encoder	Absolute encoder
1	Not connected	Not connected	Reserved
2	0 V supply	0 V supply	0 V supply
3	- Error	Not connected	Reserved
4	- Reference mark	Not connected	Reserved
5	- B signal	- B signal	MA-
6	- A signal	- A signal	SLO-
7	+ 5.25 V supply	+ 5.25 V supply	+ 5.25 V supply
8	+ 5.25 V supply	+ 5.25 V supply	+ 5.25 V supply
9	0 V supply	0 V supply	0 V supply
10	Limit switch Q	Not connected	Reserved
11	+ Error / limit switch P	Not connected	Reserved
12	+ Reference mark	Not connected	Reserved
13	+ B signal	+ B signal	MA+
14	+ A signal	+ A signal	SLO+
15	Inner screen	Inner screen	Inner screen
Shell	Outer screen	Outer screen	Outer screen

SPA3-2 installation guide

www.renishaw.com

i **NOTE:** To cater for readhead cable voltage drops the supply voltage can be adjusted, this is done via the UCCassist-2 software. The voltage can be set to 5.25 V (default), 5.75 V, 6.25 V and 6.75 V.

The voltage selected applies to all readheads and motor encoders.

i **NOTE:** Only three scale inputs are available whilst motor encoder feedback is used.

Scale signal interface circuit

SPA3-2 input circuits for CMM readhead and motor encoders.

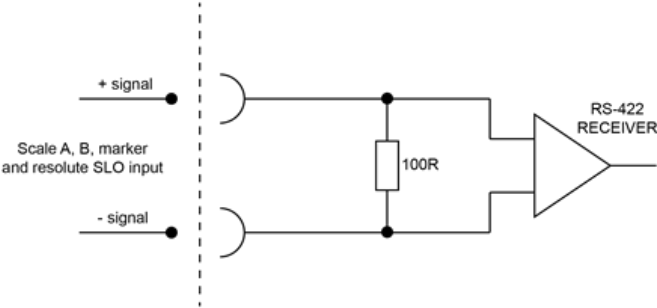

i **NOTE:** Reference input is not available on motor encoder inputs.

Absolute output interface circuit

Scale output signal circuit (BiSS protocol readheads only).

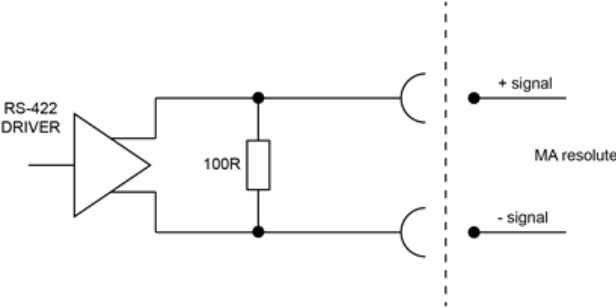

SPA3-2 installation guide

www.renishaw.com

Readhead error interface circuit

Supports Renishaw encoder error signals (e.g. for the RGH24). If an error signal is not present on the connected readhead the -error input (pin 3) must be linked to +5 V (pin 7).

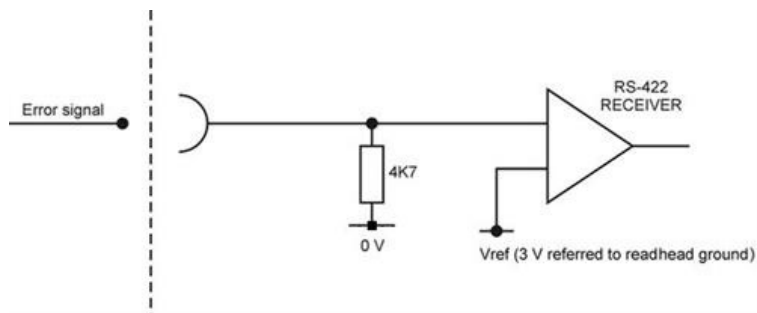

Limit switch interface circuit

Supports Renishaw encoder scale-based limit switch signals (e.g. for the RGH24).

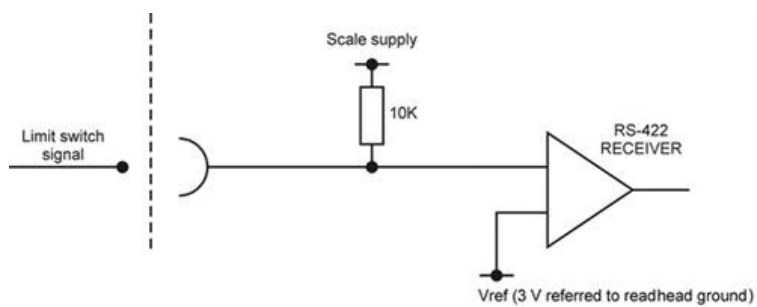

SPA3-2 installation guide

www.renishaw.com

MCU connector (9W 'D' plug)

A 9W 'D' plug is provided for direct connection of the MCULite-2, MCU5-2 and MCU W-3 joysticks.

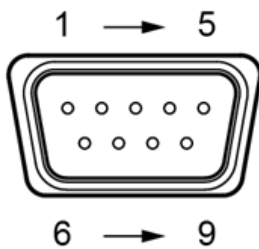

Pin number	Function
1	Ground
2	RX_B
3	RX_A
4	TX_A
5	Reserved
6	+12 V
7	TX_B
8	E-STOP_B
9	E-STOP_A
Shell	Screen



NOTE: Replacement 5 m MCU cable part number for joysticks: A-1016-8098.

SPA3-2 installation guide

www.renishaw.com

RS232 (9W 'D' plug)

A 9W 'D' plug provides RS232 communications to third party devices, this is typically a temperature sensing interface. It provides one transmit and receive signal as well as CTS and RTS lines for handshaking. DTR indicates to the other device that this device is powered.

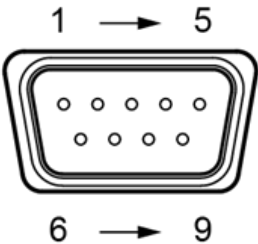

Pin	Function
1	Reserved
2	RX_IN
3	TX_OUT
4	DTR_OUT
5	0 V
6	Reserved
7	RTS_OUT
8	CTS_IN
9	Reserved
Shell	Screen

i **NOTE:** The RS232 interface is configured using the UCCassist software.

SPA3-2 installation guide

www.renishaw.com

E-STOP (9W 'D' plug)

The E-STOP connector is provided to allow connection of external emergency stop and reset switches into the SPA3-2. The machine manufacturer or product installer must perform a risk assessment (refer to BS EN ISO13849-1:2015 (or current version) para. 5.2.2.) to determine the requirements for emergency stopping and emergency switching off.

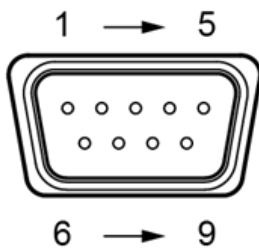

Pin number	Function
1	E-STOP A1
2	Not connected
3	0 V
4	E-STOP B1
5	E-STOP RESET A
6	E-STOP A2
7	E-STOP B2
8	Not connected
9	E-STOP RESET B



NOTE: The emergency stop function of the SPA3-2 can be used as part of a Performance Level B system as per BS EN ISO13849-1:2015 (or current version). To meet a higher performance level an external safety system must be fitted.

SPA3-2 installation guide

www.renishaw.com

E-STOP electrical characteristics

A manual reset button (refer to BS EN ISO13849-1:2015 (or current version) para. 5.2.2.) shall be included in the emergency stop system when required by the user's risk assessment. A reset switch may be needed when there is limited visibility of the danger zone from the machine's control position.

Reset switches must be located with full visibility of the danger zone and shall be sited outside the danger zone.



NOTE: If no additional emergency stop devices are to be added to the system then a bypass plug is required for the SPA3-2 emergency stop system to function.

All connections to the bypass plug shall be fitted by an electrically competent person and all wires are to be sleeved.

Any emergency stop device added to the E-STOP chain must have an electrical rating of at least 24 V 300 mA and meet the requirements of BS EN ISO 13850:2015 (or current version).

The emergency stop device shall have direct opening action with mechanical latching. The emergency stop devices shall comply with BS EN 60947-5-5:1998+A2:2017 (or current version).



CAUTION: It is strongly recommended that the CMM manufacturer or retrofitter includes a periodic test of the emergency stop (and associated reset switch, if fitted) in the maintenance instructions.

Dual SPA3-2 installations

Dual SPA3-2 installations use the same connection above, however the installation requires a special emergency stop link cable (Renishaw part number A-5623-0095). This is supplied in the 6-axis SPA3-2 kit.

This cable allows the emergency stop system to operate both SPA3-2 units. The cable ends of this cable are marked with their function. The SPA3-2 containing the MCU must have the cable end marked 'master' plugged into its external E-STOP connector, whilst the cable end marked 'slave' must be connected to the other SPA3-2.

There are six methods of implementing the external E-STOP circuit:

SPA3-2 installation guide

www.renishaw.com

E-STOP with reset implementation		E-STOP without reset implementation																													
Single pole E-STOP button:		Single pole E-STOP button:																													
<table border="1"> <thead> <tr> <th>Function</th> <th>Pin number</th> </tr> </thead> <tbody> <tr> <td>E-STOP_A1</td> <td>1</td> </tr> <tr> <td>E-STOP_B1</td> <td>4</td> </tr> <tr> <td>E-STOP_A2</td> <td>6</td> </tr> <tr> <td>E-STOP_B2</td> <td>7</td> </tr> <tr> <td>Reset A</td> <td>5</td> </tr> <tr> <td>Reset B</td> <td>9</td> </tr> </tbody> </table>	Function	Pin number	E-STOP_A1	1	E-STOP_B1	4	E-STOP_A2	6	E-STOP_B2	7	Reset A	5	Reset B	9		<table border="1"> <thead> <tr> <th>Function</th> <th>Pin number</th> </tr> </thead> <tbody> <tr> <td>E-STOP_A1</td> <td>1</td> </tr> <tr> <td>E-STOP_B1</td> <td>4</td> </tr> <tr> <td>E-STOP_A2</td> <td>6</td> </tr> <tr> <td>E-STOP_B2</td> <td>7</td> </tr> <tr> <td>Reset A</td> <td>5</td> </tr> <tr> <td>Reset B</td> <td>9</td> </tr> </tbody> </table>	Function	Pin number	E-STOP_A1	1	E-STOP_B1	4	E-STOP_A2	6	E-STOP_B2	7	Reset A	5	Reset B	9	
Function	Pin number																														
E-STOP_A1	1																														
E-STOP_B1	4																														
E-STOP_A2	6																														
E-STOP_B2	7																														
Reset A	5																														
Reset B	9																														
Function	Pin number																														
E-STOP_A1	1																														
E-STOP_B1	4																														
E-STOP_A2	6																														
E-STOP_B2	7																														
Reset A	5																														
Reset B	9																														
Dual pole E-STOP button:		Dual pole E-STOP button:																													
<table border="1"> <thead> <tr> <th>Function</th> <th>Pin number</th> </tr> </thead> <tbody> <tr> <td>E-STOP_A1</td> <td>1</td> </tr> <tr> <td>E-STOP_B1</td> <td>4</td> </tr> <tr> <td>E-STOP_A2</td> <td>6</td> </tr> <tr> <td>E-STOP_B2</td> <td>7</td> </tr> <tr> <td>Reset A</td> <td>5</td> </tr> <tr> <td>Reset B</td> <td>9</td> </tr> </tbody> </table>	Function	Pin number	E-STOP_A1	1	E-STOP_B1	4	E-STOP_A2	6	E-STOP_B2	7	Reset A	5	Reset B	9		<table border="1"> <thead> <tr> <th>Function</th> <th>Pin number</th> </tr> </thead> <tbody> <tr> <td>E-STOP_A1</td> <td>1</td> </tr> <tr> <td>E-STOP_B1</td> <td>4</td> </tr> <tr> <td>E-STOP_A2</td> <td>6</td> </tr> <tr> <td>E-STOP_B2</td> <td>7</td> </tr> <tr> <td>Reset A</td> <td>5</td> </tr> <tr> <td>Reset B</td> <td>9</td> </tr> </tbody> </table>	Function	Pin number	E-STOP_A1	1	E-STOP_B1	4	E-STOP_A2	6	E-STOP_B2	7	Reset A	5	Reset B	9	
Function	Pin number																														
E-STOP_A1	1																														
E-STOP_B1	4																														
E-STOP_A2	6																														
E-STOP_B2	7																														
Reset A	5																														
Reset B	9																														
Function	Pin number																														
E-STOP_A1	1																														
E-STOP_B1	4																														
E-STOP_A2	6																														
E-STOP_B2	7																														
Reset A	5																														
Reset B	9																														
Bypass plug:		Bypass plug:																													
<table border="1"> <thead> <tr> <th>Function</th> <th>Pin number</th> </tr> </thead> <tbody> <tr> <td>E-STOP_A1</td> <td>1</td> </tr> <tr> <td>E-STOP_B1</td> <td>4</td> </tr> <tr> <td>E-STOP_A2</td> <td>6</td> </tr> <tr> <td>E-STOP_B2</td> <td>7</td> </tr> <tr> <td>Reset A</td> <td>5</td> </tr> <tr> <td>Reset B</td> <td>9</td> </tr> </tbody> </table>	Function	Pin number	E-STOP_A1	1	E-STOP_B1	4	E-STOP_A2	6	E-STOP_B2	7	Reset A	5	Reset B	9		<table border="1"> <thead> <tr> <th>Function</th> <th>Pin number</th> </tr> </thead> <tbody> <tr> <td>E-STOP_A1</td> <td>1</td> </tr> <tr> <td>E-STOP_B1</td> <td>4</td> </tr> <tr> <td>E-STOP_A2</td> <td>6</td> </tr> <tr> <td>E-STOP_B2</td> <td>7</td> </tr> <tr> <td>Reset A</td> <td>5</td> </tr> <tr> <td>Reset B</td> <td>9</td> </tr> </tbody> </table>	Function	Pin number	E-STOP_A1	1	E-STOP_B1	4	E-STOP_A2	6	E-STOP_B2	7	Reset A	5	Reset B	9	
Function	Pin number																														
E-STOP_A1	1																														
E-STOP_B1	4																														
E-STOP_A2	6																														
E-STOP_B2	7																														
Reset A	5																														
Reset B	9																														
Function	Pin number																														
E-STOP_A1	1																														
E-STOP_B1	4																														
E-STOP_A2	6																														
E-STOP_B2	7																														
Reset A	5																														
Reset B	9																														

SPA3-2 installation guide

www.renishaw.com

Machine I/O (44W HDD socket)

The machine I/O is connected into this socket and connections made by the CMM installer using the pinout guide below. A mating connector for the machine I/O socket is provided within the SPA3-2 kit.

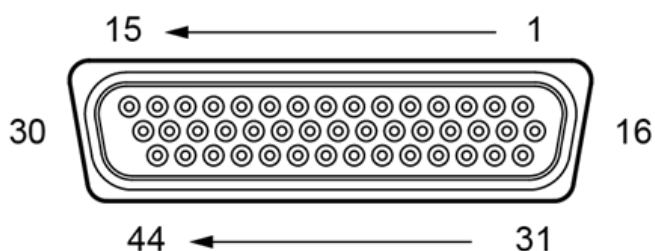

Pin number	Function	Pin number	Function
1	External I/O 24 V supply	23	Crash
2	/Enable air solenoid/ (low to enable air)	24	Reserved
3	/Axis 0 brake/ (low to release brake)	25	Axis 0 positive outer limit
4	/Axis 1 brake/ (low to release brake)	26	Axis 0 negative outer limit
5	/Axis 2 brake/ (low to release brake)	27	Axis 1 positive outer limit
6	Uncommitted output 0	28	Axis 1 negative outer limit
7	Uncommitted output 1	29	Axis 2 positive outer limit
8	Uncommitted output 2	30	Axis 2 negative outer limit
9	Uncommitted output 3	31	Axis 0 positive inner limit
10	Uncommitted output 4	32	Axis 0 negative inner limit
11	Uncommitted output 5	33	Axis 1 positive inner limit
12	Uncommitted output 6	34	Axis 1 negative inner limit
13	Uncommitted input 0	35	Axis 2 positive inner limit
14	Uncommitted input 1	36	Axis 2 negative inner limit
15	Uncommitted input 2	37	0 V
16	Uncommitted input 3	38	/Axis 3 brake/ (low to release brake)
17	Uncommitted input 4	39	Axis 3 positive outer limit
18	Uncommitted input 5	40	Axis 3 negative outer limit
19	Reserved	41	Axis 3 positive inner limit
20	De-clutch	42	Axis 3 negative inner limit
21	Reserved	43	Reserved
22	Low air pressure	44	0 V
		Shell	Screen

SPA3-2 installation guide

www.renishaw.com

All input pins

Digital input pins are not opto isolated and are internally pulled up to the external I/O +24 V supply by a 10 kΩ resistor.

To activate, the pin must be pulled 'low', below 3 V (e.g. machine I/O 0 V, pin 37 or 44).

To deactivate, the pin must be driven 'high', above 4.2 V (or open circuit).

CAUTION: The input pins must not be driven above 24 V.

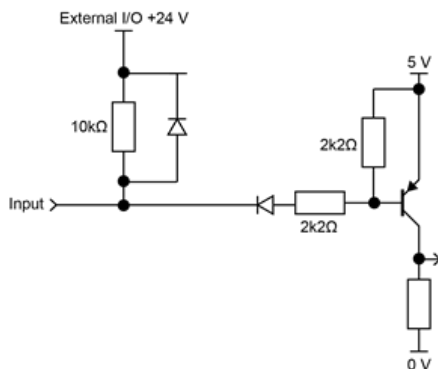

All output pins

All digital output pins have a 10 kΩ pull-up resistor to the external I/O +24 V supply, these output pins are suitable for driving devices in the range +5 V to +24 V and can sink a maximum current of 1 A. If this output is not required, then it should be left as an open circuit.

CAUTION: The output pins are not suitable for direct connection to circuits operating above +24 V.

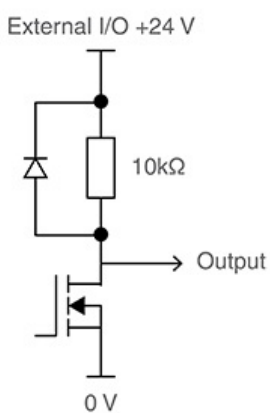

External I/O +24 V

The external I/O +24 V supply is provided to power external solenoids and solid state limit switches, this can supply a maximum current of 1 A. If higher current is required then a separate power supply must be used.

NOTE: The machine I/O +24 V supply output is shared between the machine I/O connector and the configurable I/O connector.

SPA3-2 installation guide

www.renishaw.com

Using a separate +24 V PSU

If higher current is required to supply machine solenoids, relays or limit switches then a separate PSU can be connected.

The following circuit shows how an external PSU is connected to the SPA3-2 for correct operation.

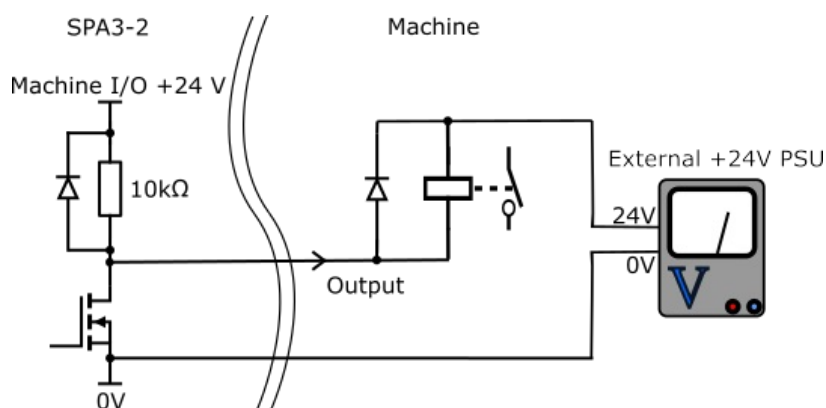

CAUTION: Flyback diodes must be directly fitted to all solenoids and relays when using an external PSU.

Enable air solenoid

An active low signal to engage an air solenoid.

Brake

These outputs (pins 3, 4, 5 and 38) are used to released the CMM axis brakes if fitted. These outputs become low to release the brakes as soon as the CMM servos are engaged.

Uncommitted outputs

These output pins can be configured to the customer's requirements via the UCCsuite software.

Uncommitted inputs

These input pins can be configured to the customer's requirements via the UCCsuite software.

De-clutch

This input on pin 20 should be pulled 'low' to signal to the controller that the CMM's drives are mechanically connected to the moving elements of the machine (i.e. in their normal condition). The input should be open circuit, or held 'high', when the CMM has been temporarily 'de-clutched' from the drive motors to allow manual positioning. The servo system will not drive the motors in this condition and will resume control at the machine's current position when the signal goes 'low'. If this capability is not required the signal should be connected to 0 V or inverted during commissioning.

SPA3-2 installation guide

www.renishaw.com

Low air pressure

The low air pressure signal should be pulled 'low' through a suitable air pressure switch. This input is monitored by the controller and when activated will remove power from the motors by causing a system fatal fault. During the commissioning process it is possible to invert this signal from an active 'low' signal to an active 'high' signal. If this capability is not required the signal should be connected to 0 V or inverted during commissioning.

 **NOTE:** It is strongly recommended to monitor supply air pressure if the CMM is using air bearings and / or a pneumatic counter balance.

Crash

The crash signal is used to inform the SPA3-2 of a collision of the mechanical structure of the machine. Typically this is a sensor that is fitted to the end of the CMM quill and if activated will remove power from the motors by causing a system fatal fault.

During the commissioning process it is possible to invert this signal. If this capability is not required for integration the signal should be connected to 0 V or inverted during commissioning.

Limit switches

The SPA3-2 controller supports both inner and outer limit switches for each of the machine axes. During the commissioning process it is possible to invert these signals. If this capability is not required for integration to the system then they should be connected to 0 V or inverted during commissioning.

Inner limit switches

If an inner limit is activated the UCC system will perform a maximum movement de-acceleration in all axes to a stop and then perform a controlled axis back-off in the opposite direction, as if a trigger event occurred.

Outer limit switches

If an outer limit is activated the UCC system will immediately disengage all servo power to the machine drives and apply the machine brakes. Recovery of this error is only possible by removing the outer limit switch activation (i.e. by moving the machine off of the switch).

0 V

This is the 0 V reference for all of the I/O signals.

 **NOTE:** All input signals can be inverted from active low to active high during the commissioning process, however care should be taken as this may prevent the input being detected in the event of input disconnection or cable break. It is therefore NOT recommended to invert inputs where possible.

SPA3-2 installation guide

www.renishaw.com

Configurable I/O (9W 'D' socket)

The connector is a 9W miniature 'D' socket, pinout as follows:

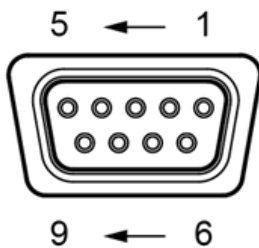

Pin number	Function	Description
1	I/O 0	General purpose input or output 0
2	I/O 1	General purpose input or output 1
3	I/O 2	General purpose input or output 2
4	I/O 3	General purpose input or output 3
5	Sync	External sync cable
6	External I/O 24 V supply	Supply provided for use on CMM switches
7	I/O 4	General purpose input or output 4
8	I/O 5	General purpose input or output 5
9	0 V	Common reference line for input and output signals
Shell	Screen	



NOTE: During commissioning general purpose pins can be configured to be either input or output.

SPA3-2 installation guide

www.renishaw.com

EXT SSC

UCC and SPA3-2 interconnection

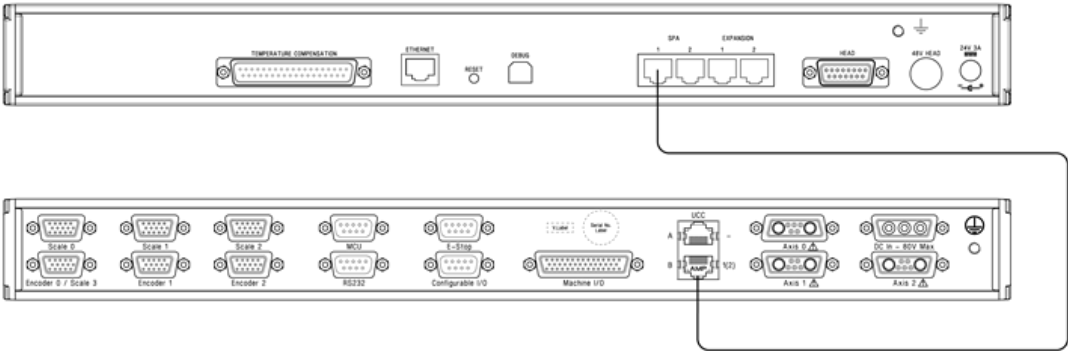

UCC and dual SPA3-2 interconnection

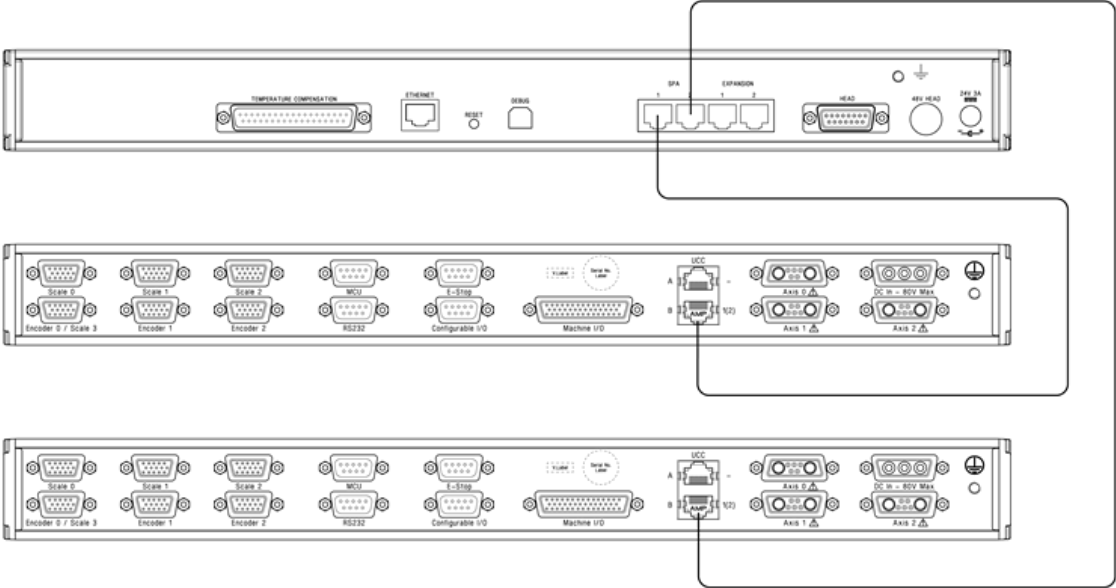

NOTE: For dual SPA3-2 installations the SPA connected to port 1 of the controller is considered the MASTER. The master SPA3-2 must be connected to the MCU, machine I/O and RS232.

SPA3-2 installation guide

www.renishaw.com

Axis 0, Axis 1 and Axis 2 motor drive connectors (7W2 'D' socket)

Each machine axis is connected to the SPA3-2 via a 7W2 socket, as shown below:

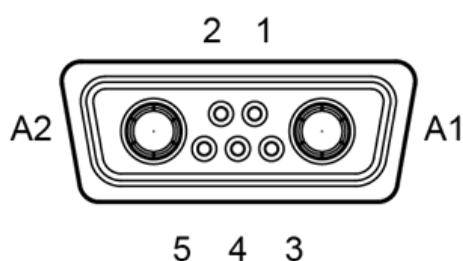

Pin number	Function
A1	Positive motor connection
A2	Negative motor connection
1	Positive tacho input *
2	Negative tacho input *
3	Screen (tacho)
4	Negative tacho input *
5	Screen (tacho)
Shell	Screen (motor)

The table shows the **default** polarity configurations for all pins, both motor output and the tacho feedback signals can be reversed in UCCassist-2 during machine commissioning.



CAUTION: Each SPA3-2 motor connection is capable of supplying up to 9.5 A peak at 80 V maximum. The actual peak current will be dependent on the size of the motor fitted and the machine performance specification, therefore the cable size needs to be calculated by the system installer or OEM.



* **NOTE:** The motor tacho input supports a maximum differential input of ± 100 V, tacho signals must be floating (i.e. not connected to ground or cable screen). Single-ended inputs can be used, however the maximum input in this configuration is ± 18 V. It is therefore recommended isolated tachometers are used.

SPA3-2 installation guide

www.renishaw.com



NOTE: Motor velocity feedback is supported through tacho, motor encoder and the incremental readhead input. It is not supported with absolute readheads.



NOTE: The SPA3-2 is designed for a continuous combined output of 10 A at 80 V (800 W), and a peak output of 960 W for 1 second.
For ambient temperatures of between 40 °C and 50 °C the output power must be limited to 400 W.



CAUTION: Unused output connectors must be blanked off when not in use to prevent the risk of electric shock.
For SPA3-2 supply voltage of over 60 V, motor cables must have a minimum cross section of 0.75 mm² as specified in BS EN 60204-1:2018 (or current version) para.12.2 and have insulation rated to at least 150 V to provide adequate protection against electric shock.



CAUTION: Hazardous voltage warning labels must be fitted to motors where hazardous voltages are present.

SPA3-2 installation guide

www.renishaw.com

DC power in (3W3 'D' plug)

The SPA3-2 is powered from an external dc power source through this connector, the dc power cable is supplied with the SPA3-2. Replacement cables are also available from Renishaw.

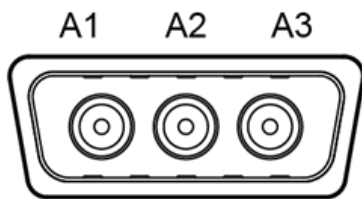

Pin number	Function
A1	0 V
A2	24 V to 80 Vdc
A3	0 V

Power requirements

The SPA3-2 requires 30 W of power to support the controller functions integrated into the unit. This must be factored into the power supply used.

DC power specification

- Voltage 24 V to 80 Vdc
- Maximum input current 12 A



WARNING: The SPA3-2 must not be powered directly from the mains.

A single fault tolerant PSU approved to BS EN IEC 62368-1:2020+A11:2020 (or current version) must be used, and connected to a supply incorporating a protective earth conductor.

SPA3-2 installation guide

www.renishaw.com

SPA3-2 maintenance



WARNING: Maintenance should only be carried out after the machine has been isolated from the electrical supply, compressed air supply or other energy sources in accordance with the machine manufacturer's instructions.

Periodically check that all mounting screws and electrical connectors are securely tightened. Electrical safety checks should include inspecting the mains cable for damage and the safety of the connections. Periodical safety checks should also include the function of the emergency stop system, including operation of all switches integrated into the system. After operating the emergency stop system, the servo amplifier system should be checked to ensure servo power can be engaged.

Advisory

It is recommended that periodical metrology tests are performed in order to identify any faults in subsystems eg air bearings, structure, cables, software etc.

Cleaning

Cleaning should be carried out with a lint free cloth on outer surfaces only as the unit is not sealed against liquid.

Filter replacement

Positive air flow is employed within the enclosure for cooling purposes. This equipment has a replaceable filter to protect it from the ingress of dust. The machine operator should inspect the condition of the filter on a regular basis. It is recommended that the filter is removed and checked / replaced as necessary during the machine installer or retrofitter's regular maintenance routine.

Exchanging / removing the air filter

The following procedure is recommended when exchanging / removing the air filter:

1. Isolate the controller via the ac power.
2. Remove the 19 inch rack mounting brackets (if fitted) by removing the two fixing screws on each side.
3. Pull both the filter retaining clips [A] away from the unit, this should permit the external filter cover [B] to be removed.
4. Remove the filter material [C] from the filter recess (replacement part number of filter is A-5518-0011).
5. Refit the filter cover and mounting brackets in the reverse order above.

SPA3-2 installation guide

www.renishaw.com

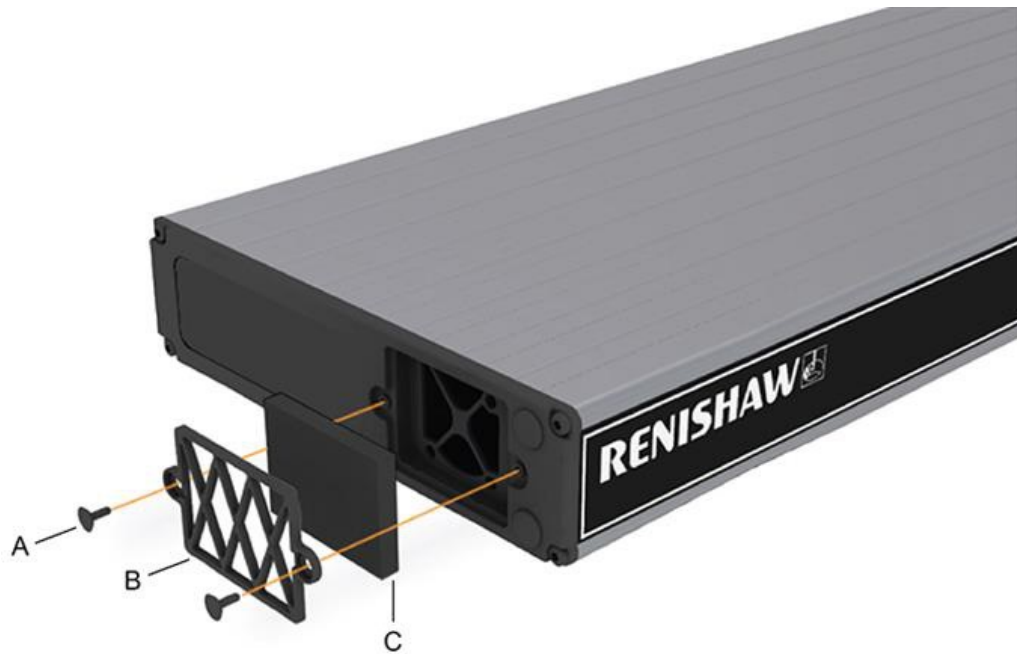

i NOTE: There are no user serviceable parts inside this unit.

SPA3-2 installation guide

www.renishaw.com

SPA3-2 troubleshooting

Fatal faults

The SPA3-2 monitors internal operational functions. If any of these reach a defined level where the system believes it is dangerous to operate a fatal fault will be applied.

When a fatal fault is detected it is not possible to engage the servo system. There may be other faults that prevent the CMM from engaging.

Reported fatal fault	Possible cause
Emergency stop	Emergency stop system activated Internal failure of servo power amplifier Faulty wiring
Air pressure	Air pressure low Blocked machine air filter Incorrectly adjusted air regulator Faulty wiring or air switch
Crash	Crash switch activated Incorrectly adjusted or faulty crash switch Faulty wiring
Scale failure	Scale readhead failed Scale miscount Scale not connected Dirty or damaged scale Faulty wiring
Overspeed	The position demand has exceeded an internal defined limit Failure of a tacho feedback Incorrect scale resolution Incompatible scale readhead Faulty wiring
Over temperature	Fan filter blocked Prolonged high output current at high environment temperature Internal servo power amplifier fault

SPA3-2 installation guide

www.renishaw.com

SPA3-2 visual diagnostics



A visual indication of the system status is provided by three LEDs on the front panel, providing assistance in diagnosing and rectifying system faults.

LED status key

	Description
	LED on
	Red flash
	Green flash
	Alternating green and red flash
	LED off
	Any condition

SPA3-2 installation guide

www.renishaw.com

Servo status	Probe seated	Error	Description
			No power to SPA3-2 or input voltage too high
			UCC2-2 mode or UCC not connected
			UCC connected waiting for download
	X		Download successful, amps not engaged E-STOP released
	X		Dynamic braking
	X		E-STOP active
	X		Amps engaged
X			Hardware error

Appendix 1 - SPA3-2 international safety statements

SPA3-2 installation guide

www.renishaw.com

BG - Безопасност



Когато върху продукта е показан този символ, потребителят трябва да направи справка с ръководството за инсталиране, за да получи информация и съвети относно безопасността.

Ако оборудването се използва по начин, който не е указан от производителя, тогава оборудването може да не е достатъчно безопасно.



ПРЕДУПРЕЖДЕНИЕ: SPA3-2 трябва да се заземи. Осигуряването на условия за заземяване на комплектната машина е отговорност на производителя на оригиналното оборудване или монтажника.



ПРЕДУПРЕЖДЕНИЕ: SPA3-2 не трябва да се захранва директно от електрическата мрежа. Трябва да се използва захранващо устройство, толерантно към единични грешки, одобрено по стандарт BS EN IEC 62368-1:2020+A11:2020 (или текущата версия), и да се свърже към захранване, включващо проводник за защитно заземяване.



ПРЕДУПРЕЖДЕНИЕ: SPA3-2 се изключва от електрозахранването чрез откачване на захранващия съединител IEC от външното захранващо устройство. Ако се изисква допълнително средство за изолация, то трябва да бъде посочено и монтирано от производителя на машината или монтажника на продукта. Изолаторът трябва да е разположен така, че операторът на СММ да има лесен достъп до него и да отговаря на стандарт BS EN 61010-1:2010 (или на текущата версия) и на всяка приложима нормативна уредба за опроводяване в страната на монтажа.



ПРЕДУПРЕЖДЕНИЕ: Поддръжката трябва да се извършва само след като машината е изолирана от електрическото захранване, подаването на състен въздух или други източници на енергия в съответствие с инструкциите на производителя на машината.

Безопасност на машината



ПРЕДУПРЕЖДЕНИЕ: Изключването или изолирането на SPA3-2 НЕ може да предотврати неочаквано движение машина. На потребителя се препоръчва да изолира устройството от електрозахранването, източника на състен въздух или други източници на енергия в съответствие с инструкциите на производителя на машината, преди навлизане в опасната зона или извършване на някакви дейности по поддръжка.



ВНИМАНИЕ: Силно се препоръчва СММ производителя или извършващия модернизацията да включат в техните инструкции за поддръжка периодичен тест на аварийния стоп, и ако има монтиран, на свързания нулиращ превключвател.

SPA3-2 installation guide

www.renishaw.com

CS - Bezpečnost

 Pokud je na výrobku zobrazen tento symbol, musí uživatel vyhledat informace a bezpečnostní doporučení v instalační příručce.

Pokud je zařízení používáno způsobem, který není specifikován výrobcem, může dojít ke snížení bezpečnosti zařízením.

 **UPOZORNĚNÍ:** Systém SPA3-2 musí být uzemněný. Za zajištění uzemnění celého stroje odpovídá výrobce OEM nebo ten, kdo ho instaluje.

 **UPOZORNĚNÍ:** Systém SPA3-2 nesmí být napájen přímo z elektrického rozvodu. Je nezbytné použít jeden zdroj napájení (PSU) odolný proti výpadkům, který splňuje normu BS EN IEC 62368-1:2020+A11:2020 (nebo aktuální verzi). PSU musí být připojen ke zdroji, který je vybaven ochranným uzemňovacím vodičem.

 **UPOZORNĚNÍ:** Systém SPA3-2 se odpojuje od zdroje napájení stejnosměrným proudem odpojením napájecího konektoru z externího PSU. Další požadované prostředky pro odpojení přívodu musí specifikovat a připojovat výrobce zařízení nebo ten, kdo zařízení instaluje. Odpojovací prvek musí být umístěn ve snadném dosahu obsluhy souřadnicového měřicího stroje a splňovat normu BS EN 61010-1:2010 (nebo aktuální verzi) a všechny příslušné státní předpisy pro zapojení platné v zemi instalace.

 **UPOZORNĚNÍ:** Údržbu lze provádět pouze po odpojení stroje od přívodu elektrického napájení, přívodu stlačeného vzduchu nebo jiných zdrojů energie v souladu s pokyny výrobce stroje.

Bezpečnost stroje

 **UPOZORNĚNÍ:** Vypnutí nebo odpojení systému SPA3-2 NEMUSÍ zabránit nečekanému pohybu stroje. Uživatel se doporučuje odpojit stroj od elektrického napájení, přívodu stlačeného vzduchu nebo jiných zdrojů energie v souladu s pokyny výrobce stroje dříve, než vstoupí do nebezpečného prostoru nebo bude provádět jakékoliv činnosti údržby.

 **UPOZORNĚNÍ:** Důrazně doporučujeme, aby výrobce souřadnicového měřicího stroje nebo firma zabývající se dodatečnou montáží zahrnuli pravidelný test nouzového zastavení a aby zmínili příslušné resetovací tlačítko (je-li k dispozici) ve svých pokynech pro údržbu.

SPA3-2 installation guide

www.renishaw.com

DA - Sikkerhed



Når dette symbol vises på produktet, skal brugeren rådføre sig med installationsvejledningen for at få oplysninger og sikkerhedsanvisninger.

Hvis udstyret anvendes på en måde, som ikke er specificeret af producenten, kan udstyrets sikkerhed blive forringet.



ADVARSEL: SPA3-2 skal have jordforbindelse. Ansvar for bestemmelserne om jordforbindelse for hele maskinen ligger hos OEM eller installatør.



ADVARSEL: SPA3-2 må ikke tilføres strøm direkte fra netstrømforsyningen.
En enkelt fejltolerant PSU, som er godkendt i henhold til BS EN IEC 62368-1:2020+A11:2020 (eller aktuel version), skal anvendes og forbindes med en forsyning, der inkorporerer en beskyttende jordledning.



ADVARSEL: Strømforsyningen til SPA3-2 isoleres ved at tage AC-strømkablet ud af den eksterne PSU. Hvis der kræves yderligere måder at isolere strømforsyningen på, skal de være specificeret og monteret af maskinproducenten eller installatøren af produktet. Afbryderen skal være placeret, så CMM-operatøren nemt kan nå den, og den skal overholde BS EN 61010-1:2010 (eller aktuel version) og eventuelle andre relevante nationale regulativer for ledningsføring i det land, hvor installationen foretages.



ADVARSEL: Vedligeholdelse må kun udføres, når maskinen er isoleret fra elforsyningen, tryklufttilførslen eller andre energikilder i overensstemmelse med maskinproducentens anvisninger.

Maskinsikkerhed



ADVARSEL: Slukning eller isolation af SPA3-2 forhindrer muligvis IKKE uventet bevægelse af maskinen. Det anbefales at brugeren isolerer maskinen fra elforsyningen, tryklufttilførslen eller andre energikilder i overensstemmelse med maskinproducentens anvisninger, før vedkommende går ind i en farezone eller udfører nogen form for vedligeholdelse.



FORSIGTIG: Det anbefales på det kraftigste, at CMM-producenten eller den, der eftermonterer, inkluderer periodisk test af nødstopet og, hvis monteret, den tilknyttede nulstillingskontakt i vedligeholdelsesanvisningerne.

SPA3-2 installation guide

www.renishaw.com

DE - Sicherheitshinweise



Wenn dieses Symbol auf dem Produkt abgebildet ist, muss der Anwender die Informationen und Sicherheitshinweise des Benutzerhandbuchs beachten.

Eine von den vom Hersteller vorgegebenen Verwendungszwecken abweichende Nutzung könnte die Sicherheit des Geräts beeinträchtigen.



WARNHINWEIS: Der SPA3-2 muss geerdet sein. Für die Erdung der kompletten Maschine ist der Maschinenhersteller bzw. Installationstechniker verantwortlich.



WARNHINWEIS: Der SPA3-2 darf nicht direkt über das Netz betrieben werden. Es muss ein nach DIN BS EN IEC 62368-1:2020+A11:2020 (bzw. aktuelle Version) zugelassenes, ausfallsicheres, fehlertolerantes Netzteil verwendet werden, das an eine Versorgung mit Schutzleiter angeschlossen ist.



WARNHINWEIS: Der SPA3-2 wird durch Lösen des Stromkabels am externen Netzteil von der Stromversorgung getrennt. Wird eine weitere Abschaltmöglichkeit benötigt, ist diese zu spezifizieren und vom Maschinenhersteller oder Installationstechniker für das Produkt einzubauen. Der Trennschalter muss für den Bediener leicht erreichbar sein und die Bestimmungen laut DIN EN IEC 61010-1:2010 (bzw. aktuelle Version) sowie auch alle anderen gültigen nationalen Verdrahtungsvorschriften im Installationsland erfüllen.



WARNHINWEIS: Vor der Durchführung von Wartungsarbeiten ist das KMG von der Stromversorgung, der Druckluftversorgung oder anderen Energiequellen gemäß der Herstelleranweisung zu trennen.

Maschinensicherheit



WARNHINWEIS: Das Abschalten des SPA3-2 oder Trennen von der Spannungsversorgung ist KEIN Schutz vor unerwarteten Maschinenbewegungen. Der Bediener sollte, gemäß der Herstelleranweisung, die Stromversorgung, Druckluft und andere Energiequellen der Maschine trennen, bevor er die Gefahrenzone betritt bzw. Wartungsarbeiten durchführt.



ACHTUNG: Es wird dringend empfohlen, dass der KMG-Hersteller oder Nachrüstbetrieb eine regelmäßige Überprüfung der Notaus-Vorrichtung und des zugehörigen Reset-Schalters (falls vorhanden) in ihren Wartungsanweisungen vorsehen.

SPA3-2 installation guide

www.renishaw.com

ΕΛ - Ασφάλεια

 Για όποιο σημείο εμφανίζεται αυτό το σύμβολο επάνω στο προϊόν, ο χρήστης πρέπει να ανατρέχει στον οδηγό εγκατάστασης για πληροφορίες και για συμβουλές ασφαλείας.

Εάν ο εξοπλισμός χρησιμοποιείται με τρόπο μη προδιαγεγραμμένο από τον κατασκευαστή, τότε η ασφάλεια του εξοπλισμού πιθανώς να παρεμποδίζεται.

 **ΠΡΟΣΟΧΗ:** Η παροχή γείωσης για ολόκληρο το μηχάνημα είναι ευθύνη του Κατασκευαστή αρχικού εξοπλισμού ή του εγκαταστάτη.

 **ΠΡΟΕΙΔΟΠΟΙΗΣΗ:** Το SPA3-2 δεν πρέπει να τροφοδοτείται απευθείας από το δίκτυο. Πρέπει να χρησιμοποιείται ένα μόνο ανθεκτικό σε σφάλματα PSU εγκεκριμένο σύμφωνα με το πρότυπο BS EN IEC 62368-1:2020+A11:2020 (ή τρέχουσα έκδοση) και να είναι συνδεδεμένο σε μια τροφοδοσία που περιλαμβάνει προστατευτικό αγωγό γείωσης.

 **ΠΡΟΕΙΔΟΠΟΙΗΣΗ:** Το SPA3-2 απομονώνεται από την παροχή ισχύος με αποσύνδεση του φινιρίσματος παροχής εναλλασσομένου ρεύματος από το εξωτερικό τροφοδοτικό. Εάν απαιτούνται οποιαδήποτε συμπληρωματικά μέσα απομόνωσης, πρέπει αυτά να καθοριστούν και να τοποθετηθούν από τον κατασκευαστή της μηχανής ή από τον εγκαταστάτη του προϊόντος. Ο απομονωτής πρέπει να βρίσκεται σε σημείο εύκολα προσβάσιμο από το χειριστή του CMM και να συμμορφώνεται με το πρότυπο BS EN 61010-1:2010 (ή την τρέχουσα έκδοση) και με οποιουδήποτε εφαρμοζόμενους εθνικούς κανονισμούς καλωδιώσεων για τη χώρα εγκατάστασης.

 **ΠΡΟΕΙΔΟΠΟΙΗΣΗ:** Η συντήρηση πρέπει να πραγματοποιείται μόνο μετά την απομόνωση του μηχανήματος από την ηλεκτρική παροχή, την παροχή πεπιεσμένου αέρα ή άλλες πηγές ενέργειας σύμφωνα με τις οδηγίες του κατασκευαστή του μηχανήματος.

Ασφάλεια μηχανήματος

 **ΠΡΟΕΙΔΟΠΟΙΗΣΗ:** Η διακοπή ή απομόνωση του SPA3-2 ΔΕΝ μπορεί να εμποδίσει μη αναμενόμενη κίνηση του μηχανήματος. Συνιστάται στο χρήστη να απομονώνει το μηχάνημα από την ηλεκτρική τροφοδοσία, τον συμπιεσμένο αέρα ή άλλες πηγές ενέργειας σύμφωνα με τις οδηγίες του κατασκευαστή μηχανήματος, προτού εισέλθει στην επικίνδυνη ζώνη ή προτού διεξάγει οποιοσδήποτε εργασίες συντήρησης.

 **ΠΡΟΣΟΧΗ:** Συστήνεται αυστηρά ο κατασκευαστής ή η επιχείρηση μετεξοπλισμού του CMM να περιλαμβάνουν στις οδηγίες συντήρησης έναν περιοδικό έλεγχο του συστήματος σταματήματος έκτακτης ανάγκης και του αντίστοιχου διακόπτη ρύθμισης εάν έχει τοποθετηθεί.

SPA3-2 installation guide

www.renishaw.com

EN - Safety

 Where this symbol is displayed on the product the user must refer to the installation guide for information and safety advice.

If the equipment is used in a manner not specified by the manufacturer then the safety of the equipment may be impaired.

 **WARNING:** The SPA3-2 must be earthed. Earthing provisions for the complete machine is the responsibility of the OEM or installer.

 **WARNING:** The SPA3-2 must not be powered directly from the mains.
 A single fault tolerant PSU approved to BS EN IEC 62368-1:2020+A11:2020 (or current version) must be used, and connected to a supply incorporating a protective earth conductor.

 **WARNING:** SPA3-2 is isolated from the power supply by disconnection of the ac power connector from the external PSU. If any additional means of isolation is required, it must be specified and fitted by the machine manufacturer or the installer of the product. The isolator must be sited within easy reach of the CMM operator and comply with BS EN 61010-1:2010 (or current version) and any applicable national wiring regulations for the country of installation.

 **WARNING:** Maintenance should only be carried out after the machine has been isolated from the electrical supply, compressed air supply or other energy sources in accordance with the machine manufacturer's instructions.

Machine safety

 **WARNING:** Switching off or isolating the SPA3-2 may NOT prevent unexpected machine movement. The user is advised to isolate the machine from the electricity supply, compressed air or other energy sources in accordance with the machine manufacturer's instructions before entering the danger zone or performing any maintenance operations.

 **CAUTION:** It is strongly recommended that the CMM manufacturer or retrofitter includes a periodic test of the emergency stop and if fitted, the associated reset switch in their maintenance instructions.

SPA3-2 installation guide

www.renishaw.com

ES - Seguridad



Si aparece este símbolo en el producto, el usuario deberá consultar la guía de instalación para obtener más información y consejos sobre seguridad.

Si no se cumplen las indicaciones especificadas por el fabricante para la utilización del equipo, la seguridad de este puede verse afectada.



ADVERTENCIA: El SPA3-2 debe estar conectado a tierra. Las conexiones de toma a tierra necesarias para toda la máquina son responsabilidad del fabricante de la máquina o el instalador.



ADVERTENCIA: El SPA3-2 no debe estar conectado directamente a la toma eléctrica. Se debe utilizar una única PSU tolerante a fallos, según la norma BS EN IEC 62368-1:2020+A11:2020 (o su versión actual), que se debe conectar a una toma de protección a tierra.



ADVERTENCIA: El SPA3-2 se aísla de la fuente de alimentación desconectando el conector de alimentación de CA de la FDA externa. Si es necesario algún otro método de aislamiento adicional, debe especificarse e instalarse por el fabricante de la máquina o el instalador del producto. El aislante se colocará en un punto de fácil acceso para el operario de la MMC y debe cumplir la norma BS EN 61010-1:2010 (o su versión actual) y las regulaciones de cableado correspondientes al país de la instalación.



ADVERTENCIA: El mantenimiento solo se debe llevar a cabo una vez que la máquina se haya aislado del suministro eléctrico o de aire comprimido, o de otras fuentes de energía, conforme a las instrucciones del fabricante.

Seguridad de la máquina



ADVERTENCIA: Apagar o aislar el SPA3-2 NO evita necesariamente un movimiento imprevisto de la máquina. Para evitar movimientos imprevistos, el operario deberá desconectar la máquina de la toma eléctrica, el aire comprimido o cualquier otra fuente de energía, según las instrucciones del fabricante, antes de acceder a zonas peligrosas o realizar operaciones de mantenimiento.



PRECAUCIÓN: Se recomienda encarecidamente que el fabricante o el técnico de retrofit de la MMC incluya pruebas periódicas de parada de emergencia y, si está instalado, del interruptor de reinicio correspondiente en las instrucciones de mantenimiento.

SPA3-2 installation guide

www.renishaw.com

ET - Ohutus



Kui seadmel on kujutatud see sümbol, peab kasutaja lugema paigaldusjuhendit, et saada infot ja nõu turvalise käsitemise kohta.

Kui seadet kasutatakse viisil, mida tootja ei ole ette näinud, võib seadme ohutus väheneda.



HOIATUS! SPA3-2 tuleb maandada. Maandamisvõimaluste loomine masinale tervikuna on seadmete tootja või paigaldaja kohustus.



HOIATUS! SPA3-2 ei tohi toita otse vooluvõrgust.

Tuleb kasutada ühte rikketaluvat PSU-d, mis on heaks kiidetud standardi BS EN IEC 62368-1:2020+A11:2020 (või praeguse versiooni) järgi, ja mis on ühendatud maandatud toitekaabliga.



HOIATUS! SPA3-2 isoleeritakse toiteallikast vahelduvvoolu toitepistiku välisest toiteallikast lahtiühendamise abil. Kui esineb vajadus lisaisoleerimisviiside järele, tuleb need määratleda ja paigaldada masina tootjal või toote paigaldajal. Isolaator peab asuma koordinaatmõõtemasina operaatorile kergelt ligipääsetavas kohas ja olema kooskõlas standardiga BS EN 61010-1:2010 (või praegune versioon) ning teiste juhtmestikke puudutavate kohalduvate riiklike eeskirjadega.



HOIATUS! Hooldust tohib teha alles pärast seda, kui masin on vastavalt masina tootja juhiste elektr-, suruõhu- või muudest energiaallikatest lahti ühendatud.

Masina ohutus



HOIATUS! SPA3-2 väljalülitamine või isoleerimine EI pruugi masina ootamatut liikumist ära hoida. Kasutajal soovitatakse isoleerida masin vooluvarustusest, suruõhust või teistest energiaallikatest masina tootja juhendi kohaselt enne, kui sisenetakse ohutsooni või asutakse tegema hooldustoiminguid.



ETTEVAATUST! On rangelt soovitatav, et koordinaatmõõtemasina tootja või modifitseerija lisaks hooldusjuhendisse regulaarse hädaseiskamise ja olemasolul sellega seotud lähtestuslüliti kontrolli.

SPA3-2 installation guide

www.renishaw.com

FI - Turvallisuutta

 Kun tuotteessa näkyy tämä symboli, käyttäjän tulee tutustua asennusoppaassa esittäviin lisätietoihin ja turvallisuusohjeisiin.

Jos laitetta käytetään valmistajan ohjeista poikkeavalla tavalla, sen turvallisuus voi olla puutteellinen.

 **VAROITUS:** SPA3-2 on maadoitettava. Koko koneen maadoituksen toteuttaminen on OEM-valmistajan tai asentajan vastuulla.

 **VAROITUS:** SPA3-2:n virta ei saa tulla suoraan verkkovirtalähteestä. Sen kanssa on käytettävä yhtä vikasietoista BS EN IEC 62368-1:2020+A11:2020 -standardin (tai uusimman version) mukaista PSU-yksikköä, ja se on kytkettävä suojamaadoitusjohtimella varustettuun virtalähteeseen.

 **VAROITUS:** SPA3-2 eristetään virransyötöstä irrottamalla vaihtovirtaliitin ulkoisesta virransyötöstä. Jos ylimääräisiä eristyskeinoja tarvitaan, tuotteen valmistajan tai asentajan on määritettävä ne ja asennettava ne koneeseen. Eristyskytkin on sijoitettava BS EN 61010-1:2010 -standardin (tai uusimman version) ja asennuspaikalla voimassa olevien sähköteknisten asennusohjeiden mukaisesti sellaiseen paikkaan, jossa se on helposti CMM-käyttäjän ulottuvilla.

 **VAROITUS:** Huolto tulee suorittaa vasta sen jälkeen, kun kone on eristetty sähkövirtalähteestä, paineilmalähteestä ja muista energialähteistä koneen valmistajan ohjeiden mukaisesti.

Koneen turvallisuus

 **VAROITUS:** SPA3-2-ohjaimen kytkeminen pois päältä tai eristäminen EI välttämättä estä odottamattomia koneen liikkeitä. Käyttäjää kehoitetaan eristämään kone sähkövirtalähteestä, paineilmalähteestä ja muista energialähteistä koneen valmistajan ohjeiden mukaisesti ennen kulkemista vaaralliselle alueelle tai huoltotehtävien suorittamista.

 **VAROITUS:** On erittäin suositeltavaa, että CMM-valmistaja tai jälkiasentaja sisällyttää hätäpysäytinten ja mahdollisesti asennettujen nollauskytkinten säännöllisen testauksen huolto-ohjeisiinsa.

SPA3-2 installation guide

www.renishaw.com

FR - Sécurité

 Lorsque ce symbole est affiché sur le produit, vous devrez consulter le manuel d'installation qui contient des informations et des conseils de sécurité.

Si l'équipement est utilisé d'une façon contre-indiquée par le constructeur, la sécurité du matériel peut alors être compromise.

 **AVERTISSEMENT** : Le SPA3-2 doit être mis à la terre. Il incombe à l'équipementier ou à l'installateur de prévoir une mise à la terre de toute la machine.

 **AVERTISSEMENT** : Le SPA3-2 ne doit pas être directement alimenté sur secteur. Un bloc d'alimentation présentant une tolérance à un défaut unique, homologué suivant la norme BS EN IEC 62368-1:2020+A11:2020 (ou sa version actuelle) doit être utilisé et branché sur une alimentation intégrant un conducteur de terre.

 **AVERTISSEMENT** : Le SPA3-2 est coupé de l'alimentation par déconnexion du c.a. du bloc d'alimentation extérieur. Si un moyen complémentaire de sectionnement est nécessaire, celui-ci devra être spécifié et installé par le constructeur de la machine ou l'installateur du produit. L'opérateur MMT doit pouvoir accéder facilement à ce sectionneur qui doit être conforme à la norme BS EN 61010-1:2010 (ou sa version actuelle) ainsi qu'à toute autre réglementation nationale de câblage en vigueur dans le pays d'installation.

 **AVERTISSEMENT** : Les interventions de maintenance ne peuvent avoir lieu qu'après avoir isolé la machine de l'alimentation électrique, de l'alimentation en air comprimé ou de toute autre source d'énergie, conformément aux instructions du constructeur de la machine.

Sécurité machine

 **AVERTISSEMENT** : Mettre le SPA3-2 hors tension ou l'isoler N'EXCLUE PAS des mouvements inattendus de la machine. Il est conseillé à l'utilisateur d'isoler celle-ci des alimentations électrique, d'air comprimé et d'autres sources d'énergie conformément aux instructions du constructeur de la machine avant de pénétrer dans la zone de danger ou de réaliser des opérations de maintenance.

 **AVERTISSEMENT** : Il est fortement recommandé au constructeur de MMT ou à l'agent de rétrofit d'inclure dans ses instructions de maintenance un test périodique de l'arrêt d'urgence et, s'il est installé, du bouton de réinitialisation associé.

SPA3-2 installation guide

www.renishaw.com

GA - Sábháilteacht

 Nuair a thaispeántar an tsiombail seo ar an táirge, ní mór d'úsáideoir an táirge féachaint ar an treoir suiteála chun eolas agus comhairle sábháilteachta a fháil.

Má úsáidtear an trealamh ar bhealach nach bhfuil mionsonraithe ag an déantúsóir, d'fhéadfadh sábháilteacht an trealaimh bheith lagaithe.

 **RABHADH:** Ní mór don SPA3-2 a bheith talmhaithe. Tá an OEM nó an suiteálaí freagrach as soláthraithe talmhaithe don mheaisín iomlán.

 **RABHADH:** Ní ceadmhach don SPA3-2 soláthar cumhachta a fháil go díreach ón phríomhlíonra. Ní mór PSU aonair lochtlamhálach atá ceadaithe de réir BS EN IEC 62368-1:2020+A11:2020 (nó leagan reatha) a úsáid agus a nascadh le soláthar a chuimsíonn seoltóir talún cosantach.

 **RABHADH:** Is féidir SPA3-2 a aonrú ón soláthar cumhachta tríd an nascóir cumhachta AC a dhínascadh den PSU seachtrach. Má tá aon mhodhanna aonraithe breise riachtanach, ní mór do dhéantúsóir an mheaisín nó suiteálaí an táirge é a mhionsonrú agus a shuiteáil. Ní mór an t-aonraitheoir a shuiteáil cóngarach don oibritheoir CMM agus é i gcomhlíonadh le BS EN 61010-1:2010 (nó leis an leagan reatha) agus le haon rialacháin náisiúnta sreangaithe atá i bhfeidhm sa tír ina suiteáiltear é.

 **RABHADH:** Níor cheart cothabháil a dhéanamh ach amháin tar éis an meaisín a bheith aonraithe ón soláthar leictreach, ón soláthar aeir comhbhrúite nó ó fhoinsí fuinnimh eile de réir threoracha déantúsóir an mheaisín.

Sábháilteacht mheaisín

 **RABHADH:** Tá seans ann NACH gcoiscfeadh gluaiseacht an mheaisín gan choinne tríd an SPA3 a mhúchadh nó a aonrú. Moltar don úsáideoir an meaisín a aonrú ón soláthar leictreachais, ó aer comhbhrúite nó ó fhoinsí fuinnimh eile de réir threoracha ó dhéantúsóir an mheaisín sula dtéitear isteach sa chrios guaise nó sula ndéantar aon oibriúcháin chothabhála.

 **AIRE:** Moltar go láidir do dhéantúsóir an CMM nó don té a aiseisteíonn an CMM tástáil thréimhsiúil ar an stop éigeandála, agus ar an lasc athshocraithe a théann leis, más ann di, a áireamh sna threoracha cothabhála.

SPA3-2 installation guide

www.renishaw.com

HR - Sigurnost

 Tamo gdje je na proizvodu prikazan ovaj simbol, korisnik mora proučiti instalacijski vodič radi informacija i sigurnosnih savjeta.

Ako se oprema upotrebljava na način koji se razlikuje od onoga koji navodi proizvođač, sigurnost opreme može se narušiti.

 **UPOZORENJE:** Uređaj SPA3-2 mora biti uzemljen. Izvođenje uzemljenja za cijeli stroj u nadležnosti je OEM-a ili instalatera.

 **UPOZORENJE:** Uređaj SPA3-2 ne smije se napajati izravno iz električne mreže. PSU mora biti tolerantan na jednostruki kvar, odobren prema normi BS EN IEC 62368-1:2020+A11:2020 (ili trenutačnoj verziji) te mora biti priključen u utičnicu sa zaštitnim uzemljenjem.

 **UPOZORENJE:** SPA3-2 se izolira od napajanja isključivanjem priključka izmjenične struje iz vanjskog PSU. Ako je potrebna neka dodatna izolacija, mora je navesti i izvesti proizvođač stroja ili instalater proizvoda. Izolator mora biti smješten tako da bude lako dostupan CMM operateru i usklađen s normom BS EN 61010-1:2010 (ili trenutačnom verzijom) te svim primjenjivim nacionalnim propisima u vezi s ožičenjem u državi u kojoj se instalira.

 **UPOZORENJE:** Održavanje se smije provoditi tek nakon što je stroj izoliran od električnog napajanja, dovoda komprimiranog zraka ili drugih izvora energije u skladu s uputama proizvođača stroja.

Sigurnost stroja

 **UPOZORENJE:** Isključenje ili izolacija uređaja SPA3-2 NE može spriječiti neočekivane pokrete stroja. Korisniku se savjetuje da prije ulaska u zonu opasnosti ili izvođenja radova održavanja stroj izolira od električnog napajanja, dovoda komprimiranog zraka ili drugih izvora energije u skladu s uputama proizvođača stroja.

 **OPREZ:** Strogo se preporučuje da proizvođač CMM stroja ili izvođač retrofita u upute za održavanje uključi periodično testiranje sigurnosnog zaustavljanja te, ako je ugrađen, prekidača za resetiranje.

SPA3-2 installation guide

www.renishaw.com

HU - Biztonság

 Amikor ezt a szimbólumot látja a terméken, akkor kérjük, tekintse meg a telepítési útmutatót további információkért és biztonsági ajánlásokért.

Ha a készüléket a gyártó által előírt módtól eltérő módon használják, akkor a készülék által nyújtott védelem csökkenhet.

 **FIGYELMEZTETÉS:** Az SPA3-2 készüléket le kell földelni. A földelési előírások követése az eredetiberendezés-gyártó vagy a telepítést végző szakember felelőssége.

 **FIGYELMEZTETÉS:** Az SPA3-2 készülék áramellátását közvetlenül a hálózatról kell biztosítani. Egyetlen, a BS EN IEC 62368-1:2020+A11:2020 szabvány (vagy annak aktuális változata) alapján jóváhagyott hibatűrő tápegységet (PSU-t) kell használni és csatlakoztatni a tápellátáshoz védő földelővezeték beépítésével.

 **FIGYELMEZTETÉS:** Az SPA3-2 készülék tápellátásról való leválasztása a váltóáramú tápcsatlakozó külső tápegységről (PSU) való leválasztásával történik. Ha egyéb leválasztásra lenne szükség, akkor azt a gép gyártójának vagy a termék beszerelőjének kell meghatározni és beszerelnie. A leválasztónak a CMM kezelője számára könnyen hozzáférhető helyen kell lennie, és meg kell felelnie a BS EN 61010-1:2010 szabványban (vagy annak aktuális változatában) foglalt előírásoknak, illetve a területileg érvényes villamos bekötési szabályoknak.

 **FIGYELMEZTETÉS:** A karbantartást kizárólag azután lehet elvégezni, hogy a gépet a gép gyártójának utasításai szerint leválasztották az elektromos hálózatról, a sűrítettlevegő-ellátásáról vagy az egyéb energiaforrásokról.

Gépbiztonság

 **FIGYELMEZTETÉS:** Az SPA3-2 készülék kikapcsolása vagy leválasztása NEM feltétlenül akadályozza meg a gép váratlan mozgását. A felhasználónak le kell választania a gépet az áramforrásról, a sűrítettlevegő-ellátásról és az egyéb energiaforrásokról a berendezés gyártójának előírásai szerint, mielőtt belépne a veszélyes területekre, illetve bármilyen karbantartási munkát végezne.

 **FIGYELEM:** Kifejezetten javasoljuk, hogy a koordináta-mérőgép gyártója vagy az utólagos felszerelést végző kivitelező írja elő a vészleállító berendezés, illetve (amennyiben van ilyen) a hozzá tartozó visszaállító kapcsoló rendszeres ellenőrzését az általa összeállított karbantartási utasításokban.

SPA3-2 installation guide

www.renishaw.com

IT - Sicurezza

 Se questo simbolo è riportato sul prodotto, consultare il manuale dell'utente per ottenere informazioni e consigli su un utilizzo sicuro.

Il grado di protezione normalmente fornito sui dispositivi potrebbe essere reso meno efficace in caso di utilizzo non conforme a quanto specificato dal produttore.

 **AVVISO:** SPA3-2 deve essere messo a terra. La responsabilità di eseguire la messa a terra dell'intera macchina è a carico dell'OEM o dell'installatore.

 **AVVISO:** SPA3-2 non deve essere collegato direttamente alla rete elettrica. Deve essere utilizzato un alimentatore conforme allo standard BS EN IEC 62368-1:2020+A11:2020 (o versione vigente), a prova di guasto e collegato ad una rete dotata di un conduttore a terra protettivo.

 **AVVISO:** SPA3-2 viene isolato elettricamente scollegando il connettore dall'alimentare esterno. Nel caso in cui fossero necessari ulteriori dispositivi di isolamento, sarà necessario specificare tale esigenza e richiedere al produttore della macchina o all'installatore di provvedere in tale senso. Il dispositivo di isolamento dovrà essere posizionato in un punto facilmente accessibile all'operatore CMM e dovrà risultare conforme allo standard BS EN 61010-1:2010 (o versione vigente) e a tutte le normative nazionali sui cablaggi in vigore nel paese di installazione.

 **AVVISO:** qualsiasi operazione di manutenzione deve essere eseguita soltanto dopo che la macchina è stata scollegata dalla rete di alimentazione, dall'aria compressa o da altre fonti di energia, in conformità alle istruzioni del produttore.

Sicurezza della macchina

 **AVVISO:** lo spegnimento di SPA3-2 o la disconnessione dall'alimentazione NON garantisce l'assenza di spostamenti imprevisti della macchina. Prima di accedere alla zona di pericolo o di eseguire operazioni di manutenzione, si consiglia di scollegare la macchina, oltre che dall'alimentazione elettrica, anche dall'aria compressa o da altre fonti di energia, in conformità alle istruzioni del produttore.

 **AVVERTENZA:** si consiglia caldamente di chiedere al produttore della CMM o a chi si occupa del retrofit di includere nel piano di manutenzione un test periodico dell'arresto di emergenza e del relativo switch (se installato).

SPA3-2 installation guide

www.renishaw.com

JA - 安全性



製品にこの記号が貼り付けられている場合は、取付ガイドの情報と安全に関する情報を参照してください。

本製品をメーカーが指定する方法以外で使用した場合、本製品の安全性が損なわれることがあります。



警告: SPA3-2 はアースに接続する必要があります。機械一式のアースの確保は、OEM または取付業者の責任に委ねられます。



警告: SPA3-2 は主電源から直接電源を取らないようにしてください。
BS EN IEC 62368-1:2020+A11:2020(または最新版)に準拠した 1 台の安定化 PSU を使用し、保護アースのある電源に接続してください。



警告: SPA3-2 は、外付け PSU からの AC 電源コネクタを外すことで電源供給を停止することができます。別途、電源供給の切断が必要な場合は、機械メーカーまたは取付業者が実施してください。ブレーカーは、CMM オペレータが簡単にアクセスできる場所に設置し、BS EN 61010-1:2010(または最新版)および各国で定められている配線に関する規則に則り設置してください。



警告: 機械メーカーの指示に従って電源、圧縮エア、その他のエネルギー源から機械を切断した後でのみ、メンテナンスを実施してください。

機械の安全性



警告: SPA3-2 のスイッチを切ったり、電源を切断しても、機械が予期せず動くことがあります。ユーザーには、危険領域に入るか、メンテナンス作業を行う前に、電源、圧縮エア、その他のエネルギー源から機械を切断することが推奨されます。



注意: CMM メーカーまたは取付業者には、緊急停止システムと、対応するリセットスイッチが取り付けられている場合は、リセットスイッチの定期的なテストをメンテナンス手順に含めることが強く推奨されます。

SPA3-2 installation guide

www.renishaw.com

LT - Sauga



Kai ant gaminio rodomas šis simbolis, naudotojas privalo informacijos ir saugos rekomendacijų ieškoti įrengimo vadove.

Jei įranga naudojama ne taip, kaip nurodo gamintojas, gali sumažėti įrangos saugumas.



ĮSPĖJIMAS: SPA3-2 turi būti įžemintas. Atsakomybė dėl viso įrenginio įžeminimo tenka originalios įrangos gamintojui arba montuotojui.



ĮSPĖJIMAS: SPA3-2 neturi būti prijungtas tiesiai prie elektros lizdo. Reikia naudoti atskirą triktims atsparų PSU, patvirtintą pagal BS EN IEC 62368-1:2020+A11:2020 (arba naujesnę versiją), prijungiant įrenginį prie elektros tinklo per apsauginį jungiklį su įžeminimu.



ĮSPĖJIMAS: atjungus kintamosios srovės maitinimo jungtį nuo išorinio maitinimo bloko (PSU), SPA3-2 yra izoliuotas nuo maitinimo. Jei reikia papildomų atskyrimo priemonių, jas turi nurodyti ir sumontuoti įrenginio gamintojas arba gaminio montuotojas. Skyriklis turi būti lengvai pasiekiamas koordinatinės matavimo mašinos operatoriui ir turi atitikti BS EN 61010-1:2010 (arba naujesnę versiją) bei kitas valstybės, kurioje montuojama mašina, elektros laidų instaliacijos taisykles.



ĮSPĖJIMAS: techninė priežiūra turi būti atliekama po to, kai įrenginys yra izoliuojamas nuo elektros tinklo, suspausto oro tiekimo tinklo ar kitų energijos šaltinių pagal įrenginio gamintojo instrukcijas.

Įrenginio sauga



ĮSPĖJIMAS: išjungus arba izoliavus SPA3-2, gali NEPAVYKTI išvengti netikėto įrenginio pajudėjimo. Naudotojui patariama pagal įrenginio gamintojo nurodymus izoliuoti įrenginį nuo elektros tinklo, suspausto oro arba kitų energijos šaltinių, paskui galima saugiai patekti į pavojaus zoną arba atlikti bet kokius techninės priežiūros darbus.



ATSARGIAI! labai rekomenduotina, kad CMM gamintojas arba modifikuotojas į savo techninės priežiūros instrukcijas įtrauktų periodinį avarinio sustabdymo sistemos testą ir susijusio paleidimo iš naujo jungiklio (jeigu toks yra) testą.

SPA3-2 installation guide

www.renishaw.com

LV - Drošība



Ja uz izstrādājuma ir redzams šis simbols, lietotājam jāizlasa uzstādīšanas pamācībā norādītā informācija un padomi par drošību.

Ja iekārtu lieto neatbilstīgi ražotāja norādēm, iekārtas drošums var mazināties.



BRĪDINĀJUMS: SPA3-2 jāiezemē. Par pareizu visas iekārtas iezemēšanu ir atbildīgs tās ražotājs vai uzstādītājs.



BRĪDINĀJUMS: SPA3-2 nedrīkst darbināt tieši no barošanas tīkla.

Jāizmanto bojājumpieciešams nepārtrauktās barošanas avots, kas apstiprināts saskaņā ar standarta BS EN IEC 62368-1:2020+A11:2020 (vai pašreizējās versijas) prasībām, un tam jābūt pievienotam strāvas padevei ar aizsargzemejuma vadu.



BRĪDINĀJUMS: SPA3-2 no strāvas padeves iespējams atvienot, atvienojot maiņstrāvas savienotāju no ārējā barošanas avota. Ja nepieciešami papildu atvienošanas līdzekļi, tie ir jānorāda un jānodrošina iekārtas ražotājam vai izstrādājuma uzstādītājam. Izolatoram jābūt novietotam tā, lai tas būtu viegli pieejams koordinēto mērīšanas mašīnu operatoram un atbilstu BS EN 61010-1:2010 (vai pašreizējās versijas) prasībām un jebkuriem saistītajiem uzstādīšanas valsts elektrotehniskajiem noteikumiem.



BRĪDINĀJUMS: apkope jāveic pēc tam, kad iekārta ir atvienota no strāvas padeves, saspiesta gaisa padeves vai citiem enerģijas avotiem saskaņā ar iekārtas ražotāja instrukcijām.

Ierīces drošība



BRĪDINĀJUMS: SPA3-2 izslēgšana vai atvienošana NEGARANTĒ to, ka ierīce neveiks neparedzētu kustību. Pirms ieiet paaugstinātās bīstamības zonā vai uzsākt apkopes darbus, lietotājam ieteicams saskaņā ar ražotāja instrukcijām atvienot ierīci no strāvas padeves, saspiesta gaisa vai citiem enerģijas avotiem.



UZMANĪBU! Koordinēto mērīšanas mašīnu ražotājam vai modernizēšanas speciālistam stingri ieteicams atbilstīgi apkopes instrukcijai regulāri pārbaudīt ārkārtas apturēšanas sistēmu un ar to saistīto atiestatīšanas slēdzi (ja uzstādīts).

SPA3-2 installation guide

www.renishaw.com

MT - Sigurtà



Kull fejn jintwera dan is-simbolu fuq il-prodott, l-utent irid jirreferi għall-gwida tal-utent u l-gwida dwar l-installazzjoni għal informazzjoni u pariri dwar is-sigurtà.

Jekk it-tagħmir jintuza b'mod li ma jkunx speċifikat mill-manifattur, il-protezzjoni pprovduta mit-tagħmir tista' titnaqqas.



TWISSIJA: SPA3-2 irid jiġi ertjat. Il-provvedimenti tal-earthing għall-magna sħiħa huma r-responsabbiltà tal-OEM jew tal-installatur.



TWISSIJA: L-iSPA3-2 irid jingħata d-dawl direttament mill-mejns. PSU uniku b'tolleranza ta' errur approvat skont BS EN IEC 62368-1:2020+A11:2020 (jew verżjoni attwali) għandu jintuza, u jiġi mqabbd għal provvista li tinkorpora konduttur protettiv tal-ert.



TWISSIJA: SPA3-2 jiġi iżolat mill-provvista tad-dawl billi tiskonnettja l-konnettur tal-provvista tad-dawl AC mill-PSU estern. Jekk kwalunkwe mezz addizzjonali ta' iżolament ikun meħtieġ, dan irid jiġi speċifikat u installat mill-manifattur tal-magna jew mill-installatur tal-prodott. L-iżolatur irid jitpoġġa fejn ikun jista' jintlaħaq faċilment mill-operatur tas-CMM u jrid ikun konformi ma' BS EN 61010-1:2010 (jew verżjoni attwali) u ma' kwalunkwe regolamenti nazzjonali applikabbli dwar il-wiring għall-pajjiż fejn ikun qed jiġi installat.



TWISSIJA: Il-manutenzjoni trid issir wara li l-magna tkun ġiet iżolata mill-provvista tad-dawl, il-provvista t'arja kompressa jew sorsi oħra ta' enerġija b'konformità mal-istruzzjonijiet tal-produuttur tal-magna.

Sigurtà tal-magna



TWISSIJA: Li titfi jew li tiżola l-SPA3-2 jista' MA jipprevenix moviment mhux mistenni tal-magna. Hu rakkomandat li l-utent jiżola l-magna mill-provvista tad-dawl, minn arja kkompressa jew minn sorsi oħrajn ta' enerġija skont l-istruzzjonijiet tal-manifattur tal-magna qabel ma jidhrol fiż-żona ta' periklu jew qabel ma jwettaq kwalunkwe xogħol ta' manutenzjoni.



ATTENZJONI: Hu rakkomandat bil-qawwa li l-manifattur tas-CMM jew tar-retrofitter jinkludi test perjodiku ta' waqfien ta' emerġenza u jekk ikun fihom, ir-reset switch fl-istruzzjonijiet tagħhom tal-manutenzjoni.

SPA3-2 installation guide

www.renishaw.com

NL - Veiligheid



Wanneer dit symbool zich op het product bevindt, dient de gebruiker de installatiegids te raadplegen voor informatie en veiligheidsadvies.

Gebruik van deze apparatuur op een manier die de fabrikant niet voorgeschreven heeft, kan de veiligheid van de apparatuur beperken.



WAARSCHUWING: De SPA3-2 moet worden geaard. Voor aardingsvoorzieningen voor de gehele machine is de OEM of installateur verantwoordelijk.



WAARSCHUWING: De SPA3-2 mag niet rechtstreeks op het lichtnet worden aangesloten. Er moet een voedingseenheid worden gebruikt met een enkele fouttolerantie die is goedgekeurd volgens BS EN IEC 62368-1:2020+A11:2020 (of de huidige versie), en deze moet worden aangesloten op een voeding met een aardingsgeleider.



WAARSCHUWING: De SPA3-2 wordt van de stroom afgesloten door de wisselstroomconnector los te koppelen van de externe voedingseenheid. Als nog een extra manier van afsluiten gevraagd wordt, dan moet die gespecificeerd en geplaatst worden door de machinefabrikant of de monteur van het product. De afsluitvoorziening moet ruim binnen het bereik van de CMM-operator aangebracht worden en voldoen aan BS EN 61010-1:2010 (of huidige versie) en de andere elektrische regels die gelden in het land van plaatsing.



WAARSCHUWING: Onderhoud mag alleen worden uitgevoerd nadat de machine is geïsoleerd van de elektrische voeding, persluchttoevoer of andere energiebronnen volgens de instructies van de machinefabrikant.

Machinerveiligheid



WAARSCHUWING: De SPA3-2 uitschakelen of afsluiten is GEEN garantie tegen onverwachte machinebewegingen. De gebruiker wordt geadviseerd om de machine volgens de instructies van de machinefabrikant af te sluiten van de voedingsspanning, perslucht en andere energiebronnen, en pas daarna gevaarlijke gebieden te betreden of onderhoud te verrichten.



WAARSCHUWING: Voor de CMM-fabrikant of installateur is het sterk aan te raden om in zijn onderhoudsinstructies een periodieke test op te nemen van de noodstop en, indien aangebracht, de resetschakelaar daarvan.

SPA3-2 installation guide

www.renishaw.com

PL - Bezpieczeństwo

 Jeżeli symbol ten znajduje się na produkcie, należy zapoznać się z podręcznikiem instalacji, aby uzyskać informacje i porady dotyczące bezpieczeństwa.

Jeżeli sprzęt jest użytkowany w inny sposób, niż określił to producent, działanie zabezpieczeń sprzętu może być ograniczone.

 **OSTRZEŻENIE:** Należy uziemić SPA3-2. Za zapewnienie warunków uziemienia całej maszyny jest odpowiedzialny producent maszyny lub instalator.

 **OSTRZEŻENIE:** SPA3-2 nie może być zasilany bezpośrednio ze złącza głównego. Należy używać zewnętrznego zasilacza przystosowanego do użytku w warunkach pojedynczej awarii, zgodnego z wymaganiami normy BS EN IEC 62368-1:2020+A11:2020 (lub jej najnowszej wersji) i podłączonego do zasilania wraz z ochronnym przewodem uziemiającym.

 **OSTRZEŻENIE:** Sterownik SPA3-2 jest izolowany od zasilania poprzez odłączenie złącza zasilania sieciowego od zewnętrznego zasilacza. Gdy wymagane są jakiegokolwiek dodatkowe środki ochrony, ich dane techniczne muszą być określone i muszą one być zainstalowane przez producenta maszyny lub instalatora produktu. Wyłącznik musi być umieszczony w taki sposób, aby zapewniać operatorowi CMM (współrzędnościowa maszyna pomiarowa) łatwy dostęp do niego oraz musi spełniać wymagania normy BS EN 61010-1:2010 (lub jej najnowszej wersji) i wszelkich przepisów dotyczących okablowania, jakie obowiązują w kraju instalacji.

 **OSTRZEŻENIE:** Konserwację należy przeprowadzać tylko po odłączeniu maszyny od zasilania elektrycznego, sprężonego powietrza lub innych źródeł energii, zgodnie z instrukcjami producenta maszyny.

Bezpieczeństwo maszyny

 **OSTRZEŻENIE:** Wyłączenie lub odizolowanie sterownika SPA3-2 może NIE zapobiec nieoczekiwanym ruchom maszyny. Zaleca się, aby przed wejściem do strefy niebezpiecznej lub wykonaniem jakichkolwiek czynności konserwacyjnych użytkownik odizolował maszynę od zasilania prądem elektrycznym, sprężonym powietrzem bądź od innych źródeł energii, zgodnie z zaleceniami producenta maszyny.

 **PRZESTROGA:** Zaleca się, aby producent lub firma montująca maszynę, załączył w swoich procedurach konserwacji okresowy test systemu awaryjnego i, jeśli zamontowano, przycisku reset.

SPA3-2 installation guide

www.renishaw.com

PT - Segurança

 Onde este símbolo é apresentado no produto, o utilizador deve consultar o guia de instalação para obter informações e dicas de segurança.

Se o equipamento for utilizado de uma maneira não indicada pelo fabricante, a segurança do equipamento pode ficar comprometida.

 **AVISO:** O SPA3-2 deve ser ligado à terra. As disposições da ligação à terra para a máquina no seu âmbito são da responsabilidade do OEM ou do instalador.

 **AVISO:** O SPA3-2 não deve ser ligado a partir da rede elétrica. Deve ser utilizada uma PSU tolerante a uma única falha aprovada pela BS EN IEC 62368-1:2020+A11:2020 (ou equivalente atual) e ligada a uma fonte que incorpore um condutor de proteção terra.

 **AVISO:** O SPA3-2 é isolado da fonte de alimentação ai desligar o conector de alimentação CA da PSU fornecida. Se forem necessários meios adicionais de isolamento, devem ser especificados e instalados pelo fabricante da máquina ou pelo instalador do produto. O isolador deve ser instalado num local fácil de alcançar pelo operador de CMM e cumprir a norma BS EN 61010-1:2010 (ou equivalente atual) e com os regulamentos de ligação nacionais aplicáveis no país de instalação.

 **AVISO:** A manutenção deve apenas ser realizada após a máquina ter sido isolada da fonte de alimentação elétrica, fornecimento de ar comprimido ou de outras fontes de energia, de acordo com as instruções do fabricante da máquina.

Segurança da máquina

 **AVISO:** Desligar ou isolar o SPA3-2 pode NÃO impedir o movimento inesperado da máquina. É aconselhado ao utilizador que isole a máquina da fonte de alimentação elétrico, ar comprimido ou outras fontes de energia, de acordo com as instruções do fabricante da máquina antes de entrar na zona de perigo ou de realizar quaisquer operações de manutenção.

 **ATENÇÃO:** É fortemente recomendado que o fabricante de CMM ou o responsável pelo reequipamento inclua um teste periódico da interrupção de emergência e, se instalado, o interruptor de reinício associado nas suas instruções de manutenção.

SPA3-2 installation guide

www.renishaw.com

RO - Instrucțiuni de siguranță

 În cazul în care acest simbol este afișat pe produs, utilizatorul trebuie să consulte ghidul de instalare pentru informații și recomandări de securitate.

Dacă echipamentul este folosit în alte condiții decât cele specificate de producător, nivelul de siguranță oferit de echipament poate fi diminuat.

 **AVERTISMENT:** SPA3-2 trebuie să fie împământat. Împământarea întregii mașini este responsabilitatea OEM sau a instalatorului.

 **AVERTISMENT:** SPA3-2 nu trebuie alimentat direct de la rețea.
Trebuie utilizată o singură sursă de alimentare tolerantă la erori omologată conform cu BS EN IEC 62368-1:2020+A11:2020 (sau versiunea curentă); aceasta trebuie conectată la o alimentare care include un conductor de împământare de protecție.

 **AVERTISMENT:** SPA3-2 este izolat de sursa de alimentare prin decuplarea conectorului de alimentare cu curent alternativ de la sursa externă. Dacă sunt necesare mijloace suplimentare de izolare, acestea trebuie specificate și montate de către producătorul sau instalatorul produsului. Echipamentul de izolare trebuie poziționat la îndemâna operatorului și trebuie să corespundă normei BS EN 61010-1:2010 (sau versiunea curentă), precum și reglementărilor naționale de cablare aplicabile în țara de instalare.

 **AVERTISMENT:** Întreținerea trebuie efectuată numai după ce mașina a fost izolată față de alimentarea electrică, alimentarea cu aer comprimat sau alte surse de energie în conformitate cu instrucțiunile producătorului.

Recomandări de siguranță

 **AVERTISMENT:** Oprirea sau izolarea dispozitivului SPA3-2 NU împiedică mișcările neprevăzute ale mașinii. Utilizatorului i se recomandă deconectarea mașinii de la sursa de energie electrică, sursa de aer comprimat și alte surse de energie, în conformitate cu instrucțiunile producătorului, înainte de a pătrunde în zona periculoasă sau de a efectua orice lucrări de întreținere.

 **ATENȚIE:** Se recomandă ca producătorul CMM sau cel care reabilitează sistemul să includă o testare periodică a opririi de urgență și dacă este instalat, o testare a butonului de resetare asociat în instrucțiunile de întreținere.

SPA3-2 installation guide

www.renishaw.com

SK - Bezpečnosť

 Ak je uvedený na výrobku tento symbol, používateľ si musí prečítať informácie a bezpečnostné odporúčania v inštaláčnej a používateľskej príručke.

Ak sa zariadenie používa spôsobom, ktorý nešpecifikoval výrobca, môže to negatívne ovplyvniť ochranu poskytovanú zariadením.

 **VÝSTRAHA:** Prístroj SPA3-2 musí byť uzemnený. Uzemnenie celého prístroja je zodpovednosťou pôvodného výrobcu zariadenia (OEM) alebo firmy vykonávajúcej inštaláciu.

 **VÝSTRAHA:** Prístroj SPA3-2 musí byť pripojený k zdroju priamo zo zásuvky. Musí sa použiť tolerancia voči jednoduchej poruche PSU schválená podľa BS EN IEC 62368-1:2020+A11:2020 (alebo aktuálna verzia) a pripojenie k napájaniu musí obsahovať ochranný uzemňovací vodič.

 **VÝSTRAHA:** Prístroj SPA3-2 je izolovaný od sieťového napájania odpojením sieťového konektora z externého zdroja napájania. Aj sú nutné akékoľvek dodatočné izolujúce zariadenia, musí ich stanoviť a dodať výrobca alebo montér tohto produktu. Izolátor musí byť umiestnený tak, aby bol ľahko dostupný pre pracovníka obsluhujúceho súradnicový merací prístroj (CMM) a musí spĺňať normu BS EN 61010-1:2010 (alebo aktuálnu verziu) a všetky príslušné národné predpisy týkajúce sa káblových rozvodov platné v krajine inštalácie.

 **VÝSTRAHA:** Údržba sa smie vykonávať len vtedy, ak bol prístroj izolovaný od elektrického napájania, rozvodu stlačeného vzduchu alebo iných zdrojov energie v súlade s inštrukciami výrobcu prístroja.

Bezpečnosť prístroja

 **VÝSTRAHA:** Vypnutie alebo izolácia zariadenia SPA3-2 NEMUSÍ zabrániť neočakávanému pohybu prístroja. Pred vstupom do nebezpečnej zóny alebo pred vykonaním ľubovoľných údržbových postupov sa používateľovi odporúča izolovať prístroj od zdroja elektrickej energie, stlačeného vzduchu alebo iných zdrojov energie v súlade s pokynmi výrobcu prístroja.

 **UPOZORNENIE:** Dôrazne sa odporúča, aby výrobca súradnicového meracieho prístroja (CMM) alebo firma vykonávajúca jeho inštaláciu zahrnuli do ich údržbových pokynov pravidelné testovanie núdzového vypnutia a príslušného resetovacieho spínača, ak je namontovaný.

SPA3-2 installation guide

www.renishaw.com

SL - Varnost



Če je na izdelku nameščen ta simbol, mora uporabnik upoštevati informacije in nasvete glede varnosti v navodilih za namestitev.

Drugačna uporaba opreme, kot jo je predpisal proizvajalec, lahko poslabša varnost opreme.



OPOZORILO: SPA3-2 je treba ozemljiti. Ozemljitev celotnega stroja je odgovornost proizvajalca originalne opreme ali inštalaterja.



OPOZORILO: SPA3-2 se ne sme napajati neposredno iz električnega omrežja.

Uporabiti je treba napajalnik, ki je odporen na posamične napake in odobren skladno s standardom BS EN IEC 62368-1:2020+A11:2020 (ali trenutno veljavno različico), ter ga povezati z napajanjem, ki vključuje zaščitni ozemljitveni vodnik.



OPOZORILO: SPA3-2 se od vira napajanja loči z odklopom napajalnega priključka iz zunanega napajalnika. Če so potrebni dodatni ukrepi za ločevanje, jih mora zasnovati in vgraditi proizvajalec stroja ali inštalater izdelka. Ločilno sredstvo mora biti nameščeno v doseg operatorja KMS in mora biti skladno s standardom BS EN 61010-1:2010 (ali trenutno veljavno različico) ter z vsemi veljavnimi državnimi predpisi o električnih napeljavah v državi inštalacije.



OPOZORILO: Vzdrževanje se lahko izvaja šele, ko je stroj ločen od električnega napajanja, dovajanja stisnjenega zraka ali drugih virov energije v skladu z navodili proizvajalca stroja.

Varnost stroja



OPOZORILO: Izklop ali ločitev naprave SPA3-2 morda NE bo preprečila nepričakovanih premikov stroja. Uporabniku priporočamo, naj loči stroj od virov električnega napajanja, stisnjenega zraka in drugih virov energije v skladu z navodili proizvajalca stroja, preden vstopi v nevarno območje ali se loti vzdrževalnih del.



POZOR: Priporočamo, da proizvajalec KMS ali izvajalec naknadne vgradnje v navodilih za vzdrževanje predvidi tudi redne preskuse zaustavitve v sili in stikala za ponastavitev, če je vgrajeno.

SPA3-2 installation guide

www.renishaw.com

SV - Säkerhet



När den här symbolen visas på produkten måste användaren läsa i användarhandboken för att få information och råd om säkerheten.

Om utrustningen används på ett sätt som tillverkaren inte har avsett kan utrustningens säkerhet försämrats.



WARNING: SPA3-2 måste vara jordad. Hela maskinen måste jordas – detta ansvar åligger återförsäljaren eller installatören.



WARNING: SPA3-2 får inte drivas direkt från elnätet.

En strömadapter med enkelfeltolerans som är godkänd enligt BS EN IEC 62368-1:2020+A11:2020 (eller aktuell version) måste användas och anslutas till en elförsörjning med skyddande jordledare.



WARNING: För att koppla ur SPA3-2 från strömförsörjningen drar du ur kontakten på den externa strömadaptern. Om det krävs andra metoder för att bryta strömmen måste maskintillverkaren eller installatören specificera och montera dessa. Brytaren måste sitta så att koordinatmätmaskinens operatör enkelt kan komma åt den. Den ska följa SS-EN 61010-1:2010 (eller aktuell version) och andra tillämpliga nationella regler för elinstallation i det land där installationen sker.



WARNING: Underhåll får endast utföras efter att maskinen har kopplats bort från elförsörjningen, tryckluftsförsörjningen eller andra energikällor i enlighet med maskintillverkarens anvisningar.

Maskinsäkerhet



WARNING: Även om SPA3-2 stängs av eller kopplas ur så KAN ÄNDÅ oväntade maskinrörelser uppstå. Användaren rekommenderas att bryta strömmen, tryckluften och andra energikällor till maskinen i enlighet med maskintillverkarens anvisningar, innan någon person går in i riskzonen eller utför något underhåll.



SE UPP: Vi rekommenderar starkt att tillverkaren eller eftermonteraren av koordinatmätmaskiner inkluderar ett periodiskt test av nödstoppen samt eventuellt tillhörande återställningsknapp i sina underhållsinstruktioner.

SPA3-2 installation guide

www.renishaw.com

ZH-TW - 安全



產品上若標有此符號，使用者必須參閱安裝指南，瞭解相關資訊與安全須知。

如果裝置使用方式與製造商要求的方式不符，則裝置提供的保護功能可能會減弱。



警告：SPA3-2 必須接地。OEM 或安裝人員應負責整個機器的接地措施。



警告：SPA3-2切勿直接從主電源供電。

必須使用經 BS EN IEC 62368-1:2020+A11:2020(或當前版本)批准的單一不斷電電源供應器，並將其連接到包含保護性接地導體的電源。



警告：可以透過斷開外部電源供應器的交流電源接頭來切斷 SPA3-2 的電源。如果需要其他隔離措施，必須由機器製造商或產品安裝人員指定及安裝。隔離物必須設置在 CMM 操作員可及之處，並符合 BS EN 61010-1:2010 (或當前版本) 的標準與安裝國家適用的國家線路法規。



警告：僅應在按照機器製造商的指示將機器與供電、壓縮空氣供應或其他能源隔離之後，才能進行維護。

機器安全性



警告：關閉或隔離 SPA3-2 並無法防止不可預期的機器移動。建議使用者在進入危險區或執行任何維護作業前，先依據機器製造商的指示，隔離機器的供電、壓縮空氣或其他能源。



警告：強烈建議 CMM 製造商或改裝人員納入緊急停止的定期測試，若已納入，相關人員可在維護指示中重設開關。

SPA3-2 installation guide

www.renishaw.com

ZH - 安全须知



如果产品上显示此符号，用户必须参见“安装指南”，了解相关信息和安全建议。

如果设备使用方式与制造商要求的方式不符，则可能会损害设备的安全性能。



警告: SPA3-2 必须布置地线。整台机器的地线布置由 OEM 或安装服务商负责。



警告: SPA3-2 不能直接由主电源供电。

必须使用符合 BS EN IEC 62368-1:2020+A11:2020(或当前版本)标准的单个容错电源装置，并连接到带有保护性接地导体的电源上。



警告: 可以通过断开外部电源装置的交流电源接头来切断 SPA3-2 的电源。如果需要任何形式的额外绝缘隔离措施，必须由设备制造商或产品安装人员指定并安装。隔离器必须位于 CMM 操作人员易于操作的位置，并且符合 BS EN 61010-1:2010(或当前版本)和设备安装所在国适用的国家布线标准规定。



警告: 只有在按照机器制造商的说明断开机器电源、压缩气源或其他能源来源以后才能进行维护。

机器安全须知



警告: 关闭或隔离 SPA3-2 也许不能防止机器意外移动。建议用户在进入危险区域或执行任何维护操作前，须按照机器制造商的说明断开机器电源、压缩气源或其他能量来源。



小心: 强烈建议坐标测量机制造商或改造商在其维护说明中包含对急停安全系统进行定期测试和相关复位开关(如安装)的内容。

Renishaw plc
New Mills, Wotton-under-Edge
Gloucestershire, GL12 8JR
United Kingdom

T +44 (0)1453 524524
F +44 (0)1453 524901
www.renishaw.com/cmmsupport



**For worldwide contact details,
please visit our main website at
www.renishaw.com/contact**